

Installation & Assembly

"IMPORTANT, RETAIN FOR FUTURE REFERENCE: READ CAREFULLY"

German: WICHTIG, FÜR SPÄTERE NACHSCHLAGE AUFBEWAHREN: SORGFÄLTIG LESEN

Spanish: IMPORTANTE, GUARDAR PARA REFERENCIA FUTURA: LEER ATENTAMENTE

Italian: IMPORTANTE, CONSERVARE PER RIFERIMENTI FUTURI: LEGGERE ATTENTAMENTE

French: IMPORTANT, À CONSERVER POUR RÉFÉRENCE FUTURE : LIRE ATTENTIVEMENT

! 1. Periodically check that all components are tightly secured.

2. Assemble on a flat, clean, and soft surface.

3. Confirm all parts are present prior to assembly.

4. Prepare electric tools in advance for a quicker installation.

1. Prüfen Sie regelmäßig, ob alle Komponenten fest sitzen.

2. Montieren Sie das Gerät auf einer ebenen, sauberen und weichen Oberfläche.

3. Vergewissern Sie sich vor dem Zusammenbau, dass alle Teile vorhanden sind.

4. Bereiten Sie Elektrowerkzeuge im Voraus vor, um eine schnellere Installation zu ermöglichen.

1. Vérifiez périodiquement que tous les composants sont bien fixés.

2. Assemblez le tout sur une surface plane, propre et douce.

3. Confirmez que toutes les pièces sont présentes avant l'assemblage.

4. Préparez les outils électriques à l'avance pour une installation plus rapide.

1. Controllare periodicamente che tutti i componenti siano fissati saldamente.

2. Assemblare su una superficie piana, pulita e morbida.

3. Assicursarsi che siano presenti tutte le parti prima dell'assemblaggio.

4. Preparare gli strumenti elettrici in anticipo per un'installazione più veloce.

1. Revise que todos los componentes estén asegurados con regularidad.







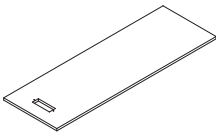
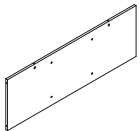
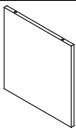
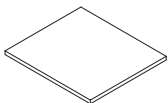

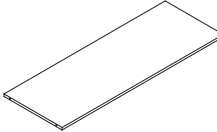
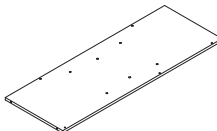
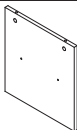
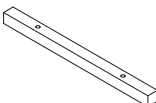

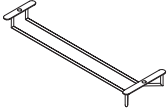
2. Monte sobre una superficie que sea plana, limpia y suave.



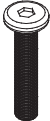



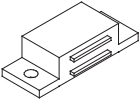

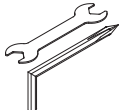
3. Antes de montar el producto, revise que tenga todas las piezas a mano.

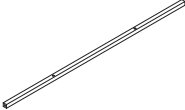
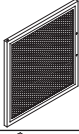
4. Para facilitar la instalación, prepare las herramientas eléctricas necesarias con tiempo.

Item no. Nr. N° d'article Articolo No. Artículo No.	Reference Image Referenzbild Image de référence Immagine di riferimento Imagen de referencia	Qty. Menge Qté. Qtà Cant.
1		X1
3		X1
5		X1
7		X1

Item no. Nr. N° d'article Articolo No. Artículo No.	Reference Image Referenzbild Image de référence Immagine di riferimento Imagen de referencia	Qty. Menge Qté. Qtà Cant.
2		X1
4		X1
6		X1
8		X1

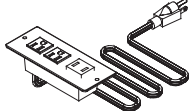
Item no. Nr. N° d'article Articolo No. Artículo No.	Reference Image Referenzbild Image de référence Immagine di riferimento Imagen de referencia	Qty. Menge Qté. Qtà Cant.
9		X4
11		X2
13		X1
A		X6
C	 M6*30mm	X8
E	 M6*10mm	X13
G	 ST4*12mm	X8
I		X10
K		X3
M		X3
O		X4
Q		X1

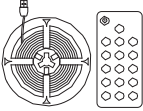
Item no. Nr. N° d'article Articolo No. Artículo No.	Reference Image Referenzbild Image de référence Immagine di riferimento Imagen de referencia	Qty. Menge Qté. Qtà Cant.
10		X2
12		X3
14		X1
B	 M6.3*40mm	X22
D	 M6*35mm	X6
F	 M6	X1
H	 M4*18mm	X6
J		X1
L		X6
N		X2
P		X1

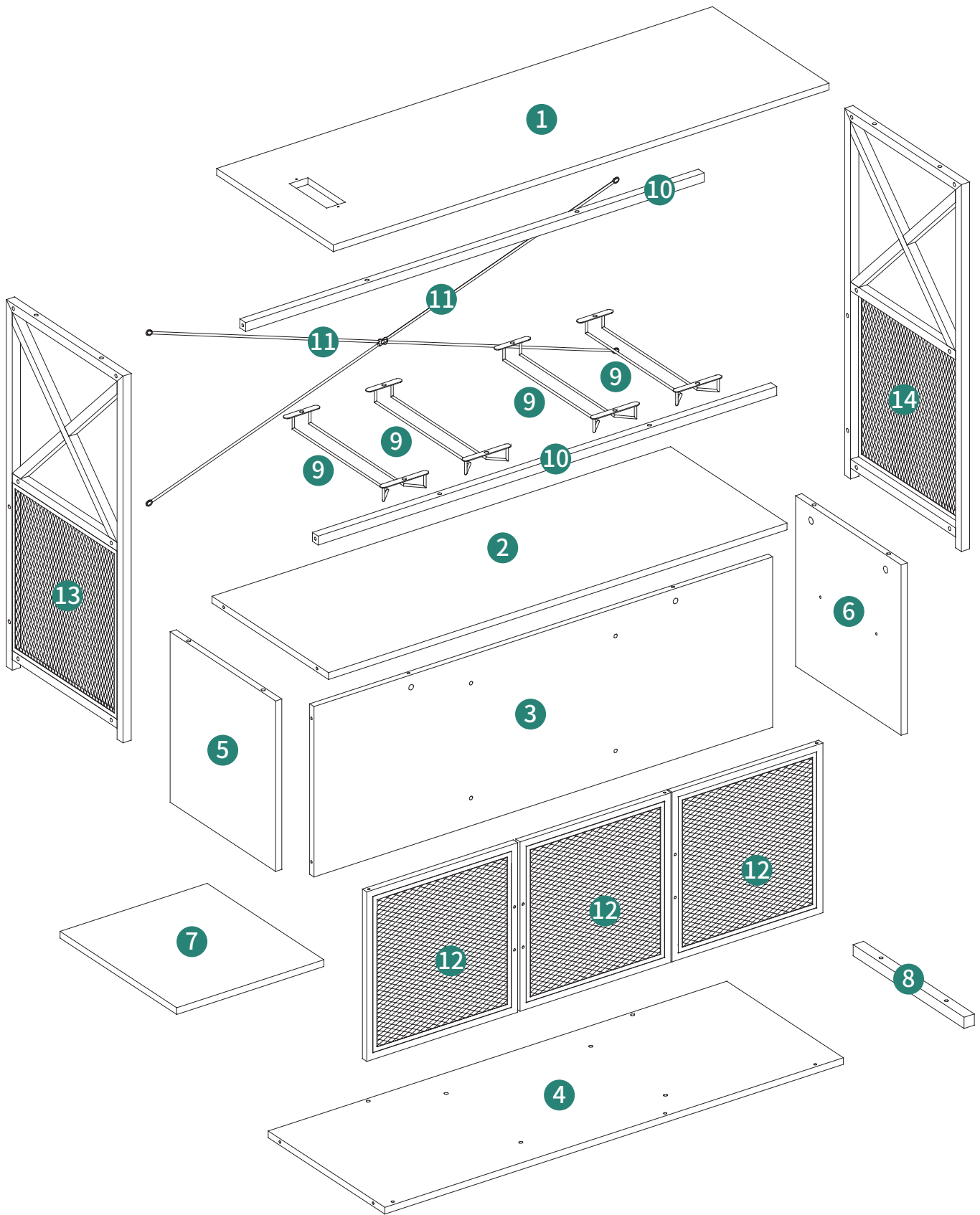

1

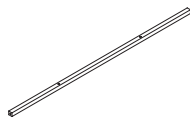

⑩2pcs



⑬1pc



⑭1pc



ⓓ4pcs

Confirm that the iron frames are well-placed and facing the correct direction. Per the below picture, the holes marked by triangles on Part ⑬ and Part ⑭ should face the same direction.

Stellen Sie sicher, dass die Eisenrahmen richtig platziert sind und in die richtige Richtung zeigen. Die durch Dreiecke markierten Löcher auf Teil ⑬ und Teil ⑭ sollten in die gleiche Richtung zeigen.

Vérifiez que le cadre du fer est dans la bonne position et orientation. Suivant le schéma ci-dessous, les trous marqués de triangles dans la partie ⑬ et la partie ⑭ doivent être orientés dans la même direction.

Verificare che i telai di ferro siano posizionati correttamente e rivolti nella direzione corretta. Come Nella figura seguente, i fori contrassegnati da triangoli sulla Parte ⑬ e sulla Parte ⑭ dovrebbero essere rivolti nella stessa direzione.

Coloque y oriente el marco de hierro correctamente. Según la imagen siguiente, los agujeros marcados con triángulos en la parte ⑬ y la parte ⑭ deben estar orientados en la misma dirección.

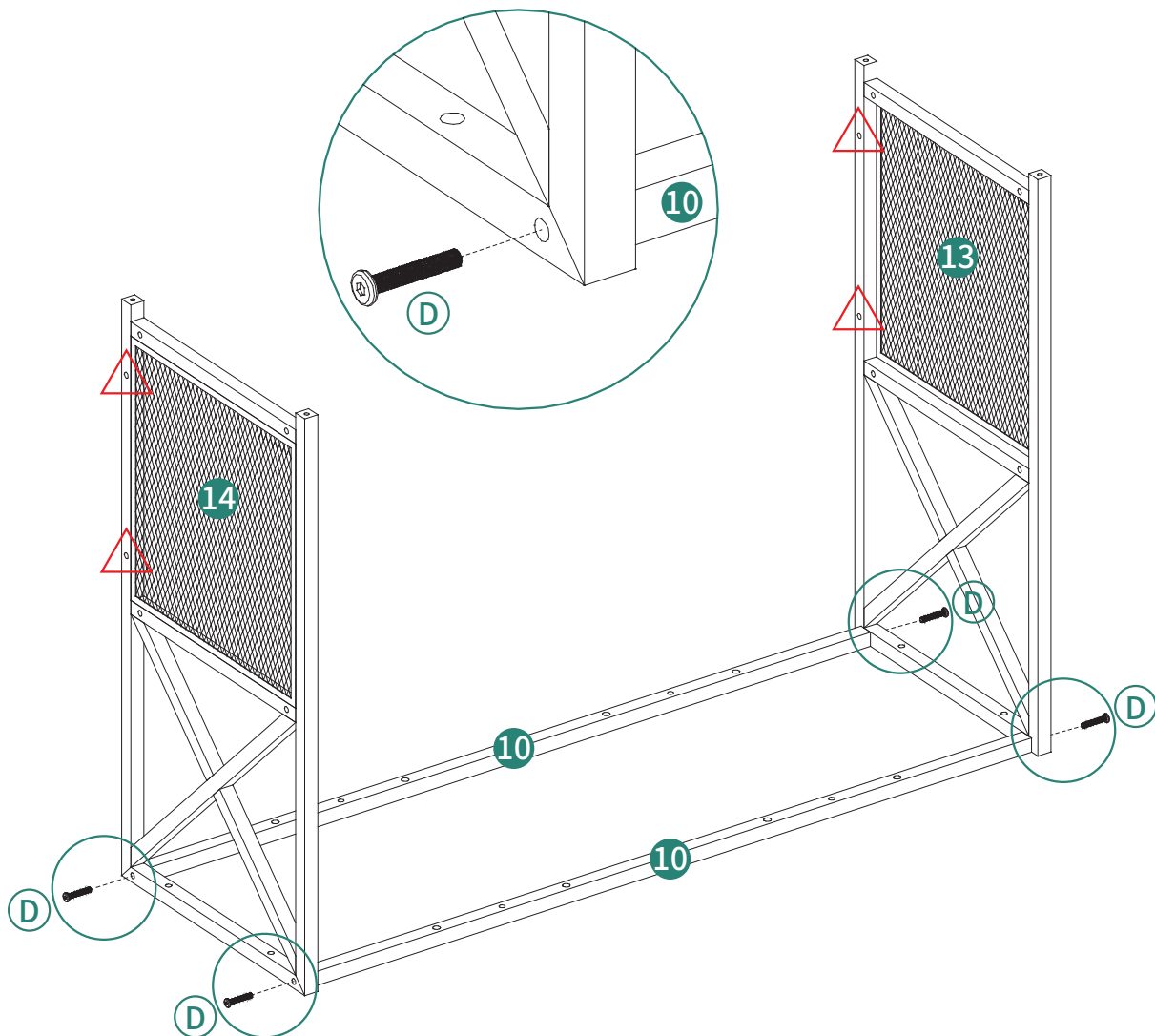

2

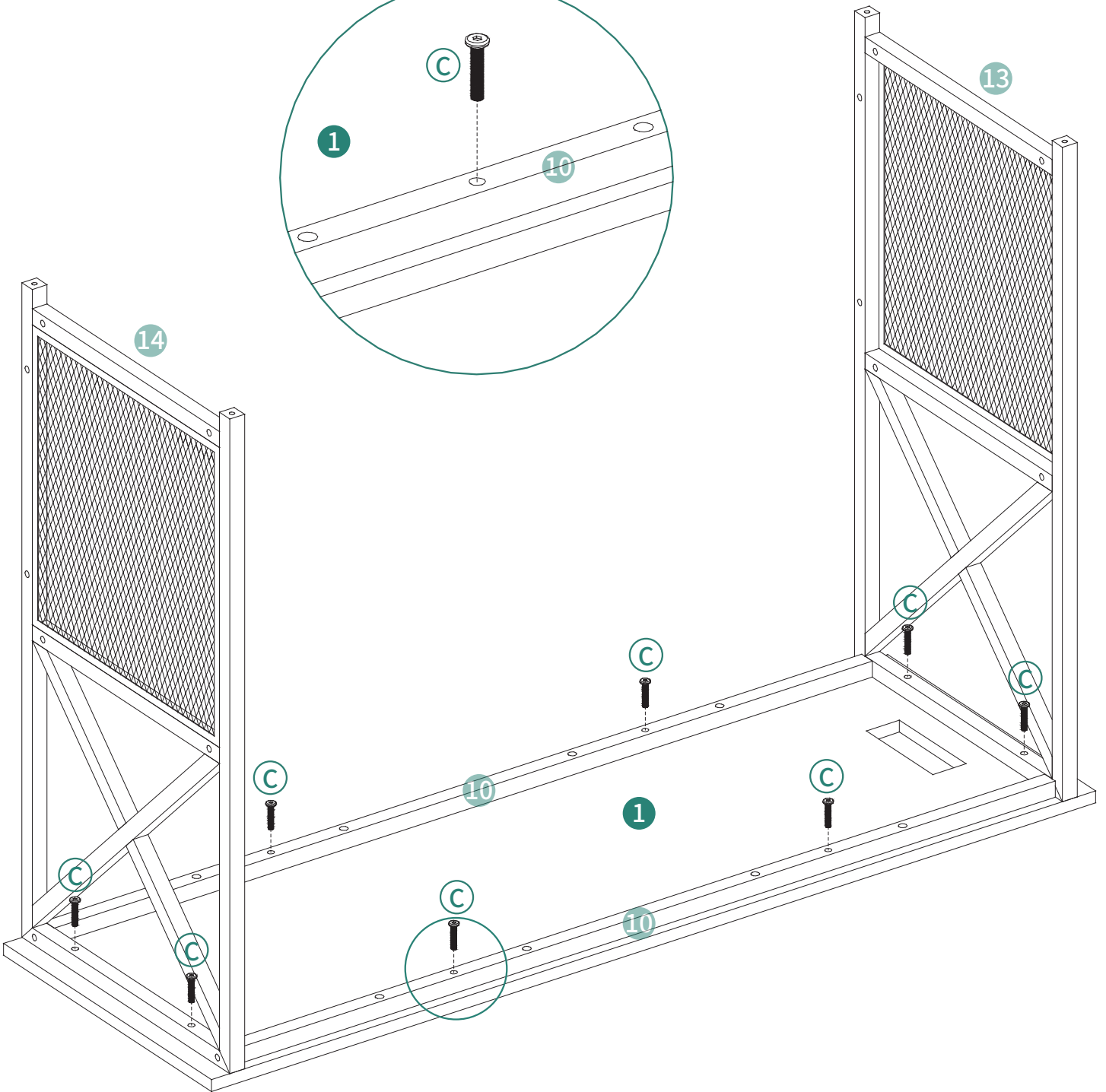
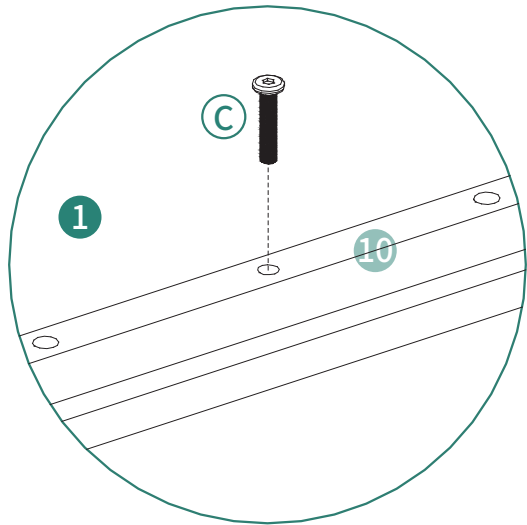
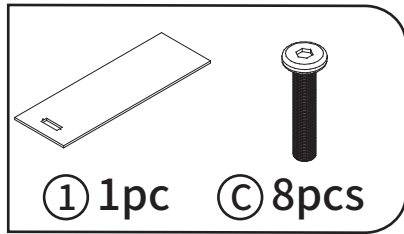

3

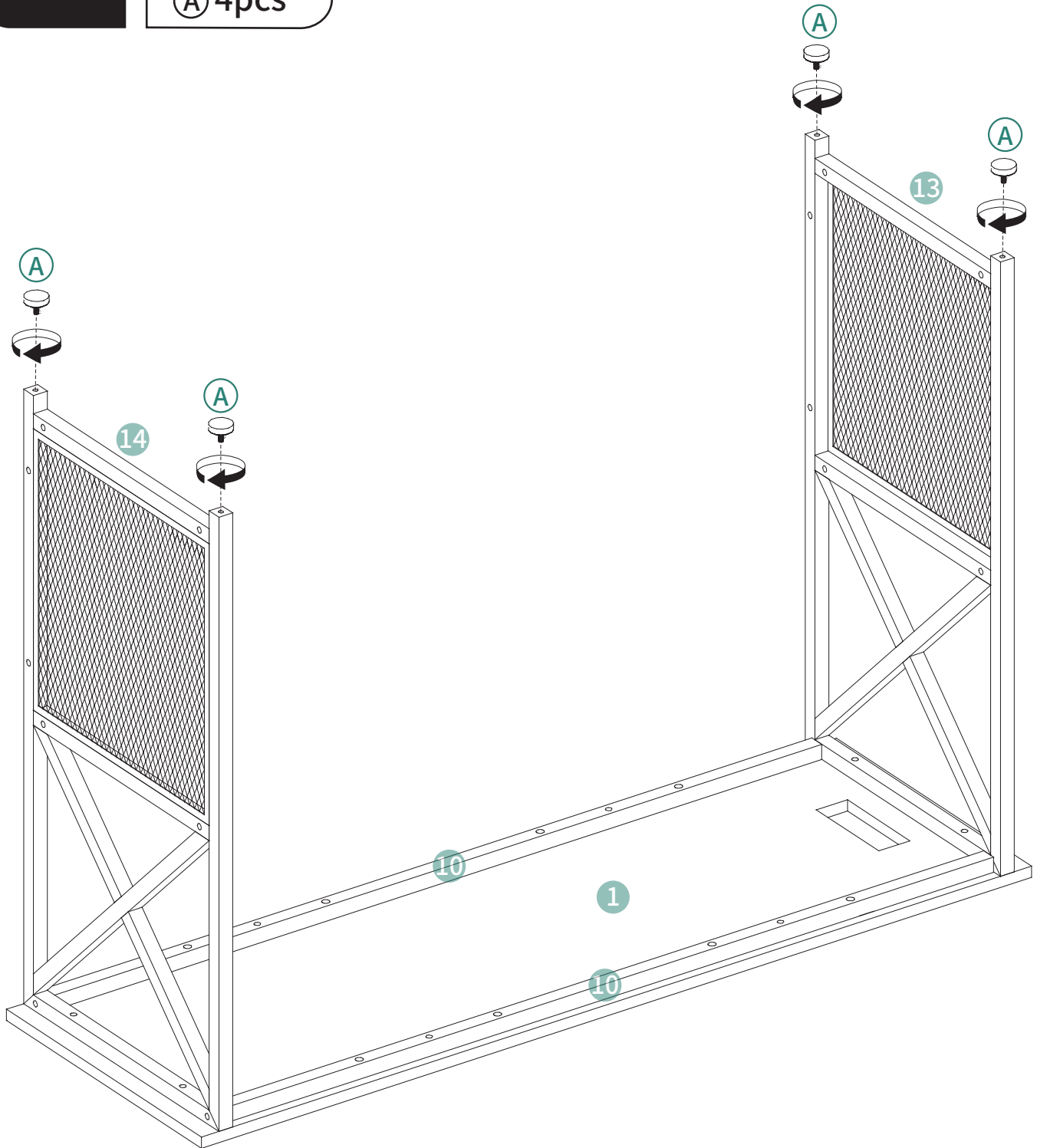
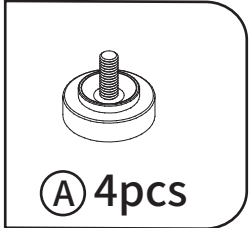

4

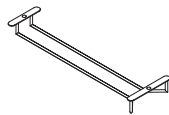

⑨ 4pcs ⑤ 8pcs

Pay attention to the installation direction of accessory 9.

Achten Sie auf die Installationsrichtung von Zubehör 9.

Faites attention à la direction d'installation de l'accessoire 9.

Fare attenzione alla direzione di installazione dell'accessorio 9.

Preste atención a la dirección de instalación del accesorio 9.

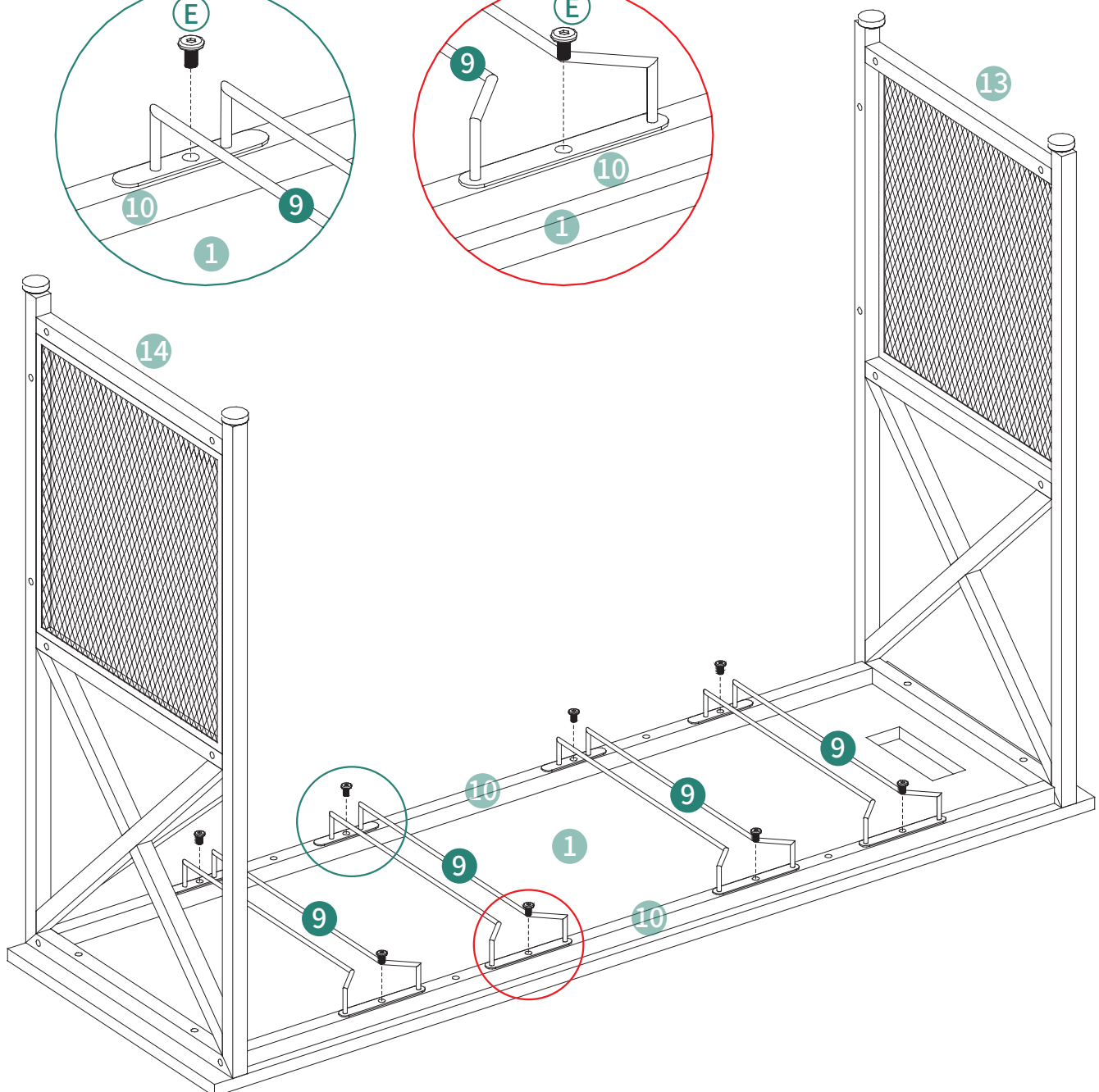
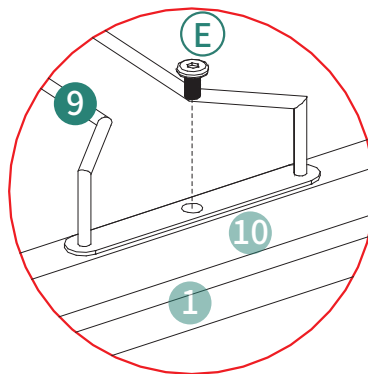
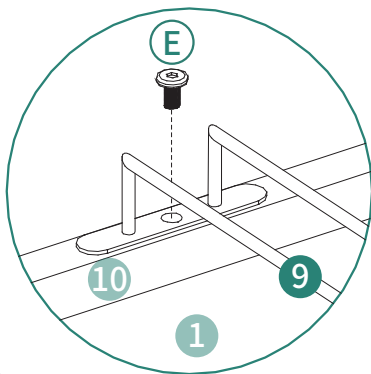

5



①① 2pcs

④ 5pcs

⑤ 1pc

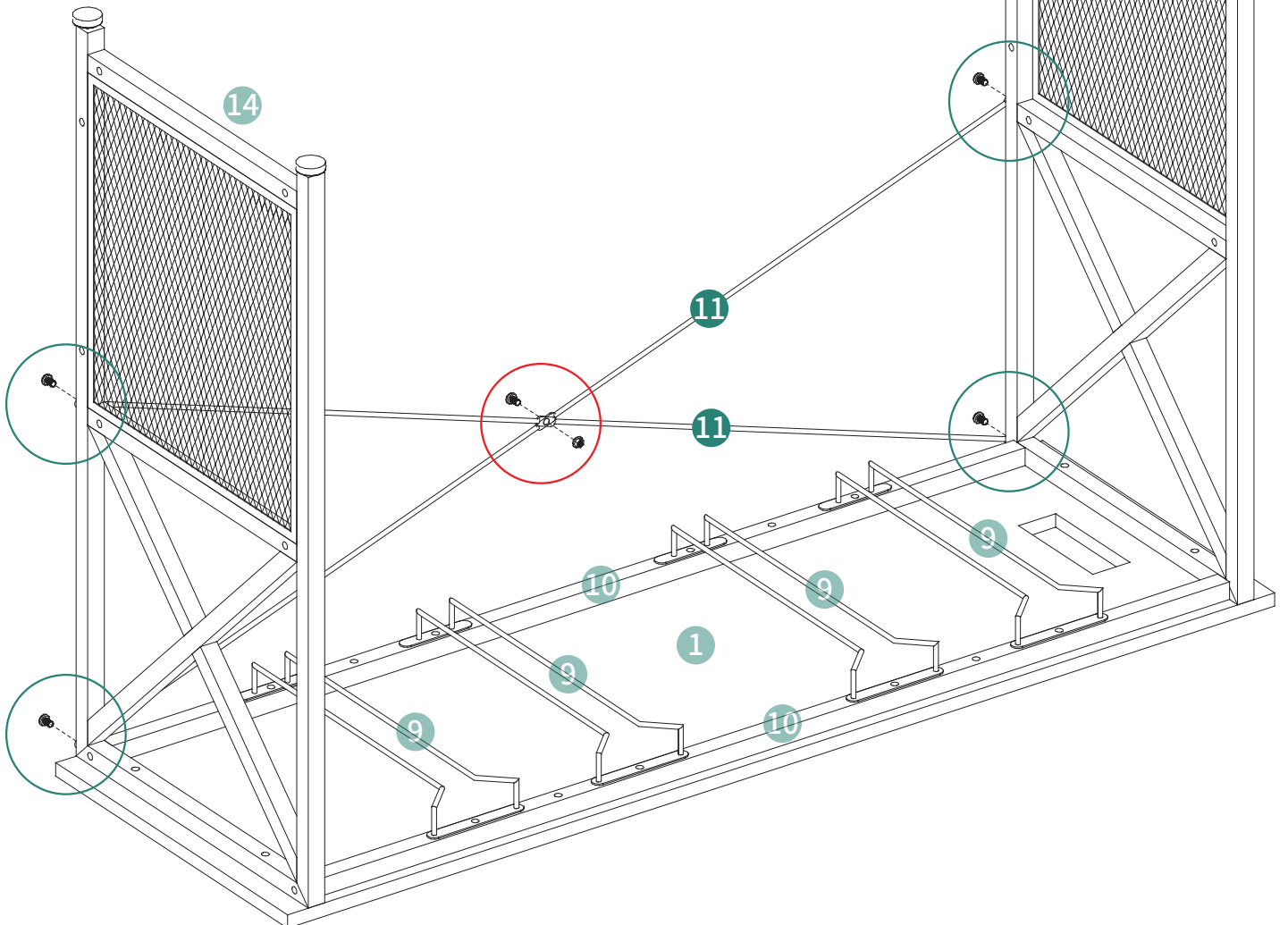
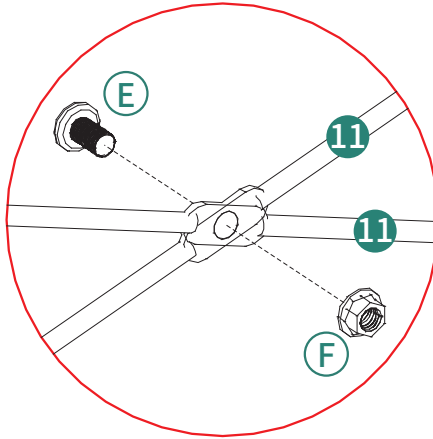
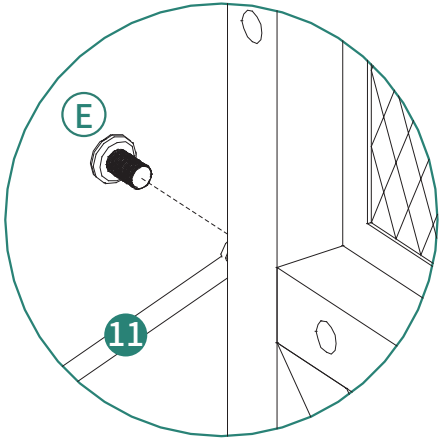

6

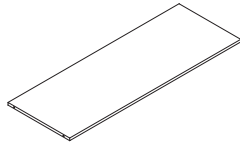

② 1pc



ⓐ 6pcs



Ⓛ 6pcs

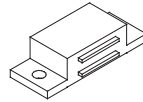

Ⓜ 3pcs

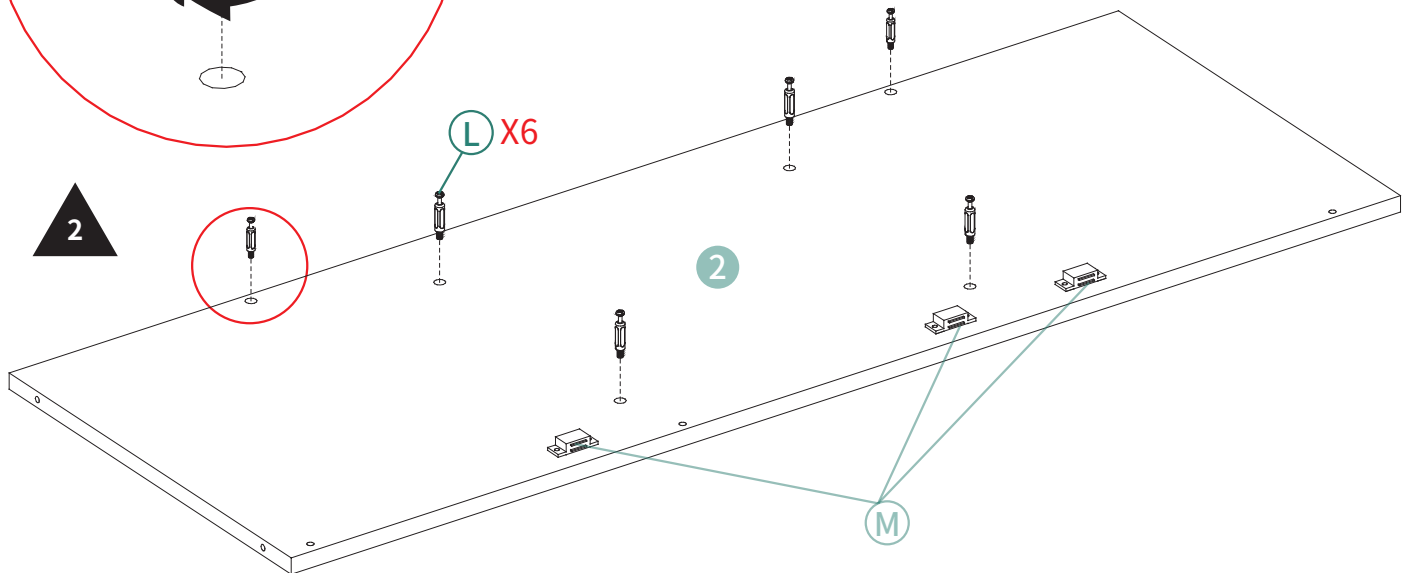
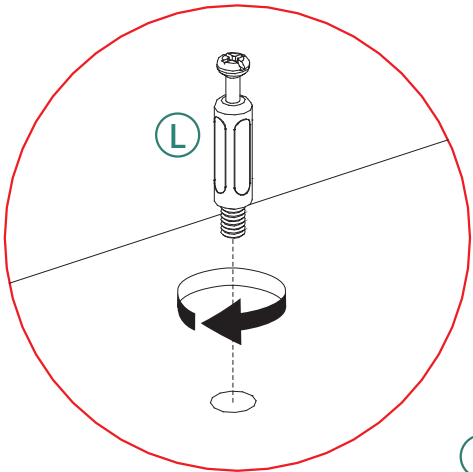
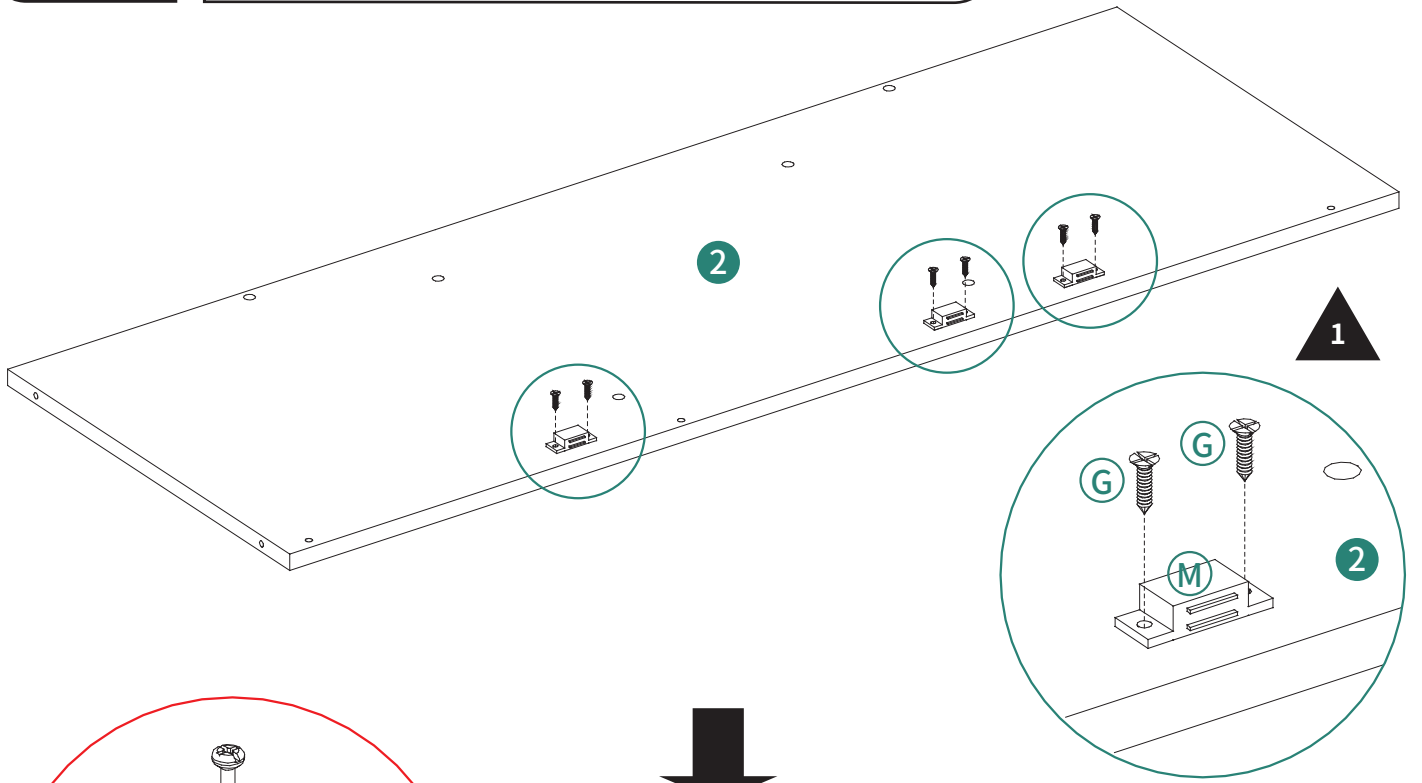

7

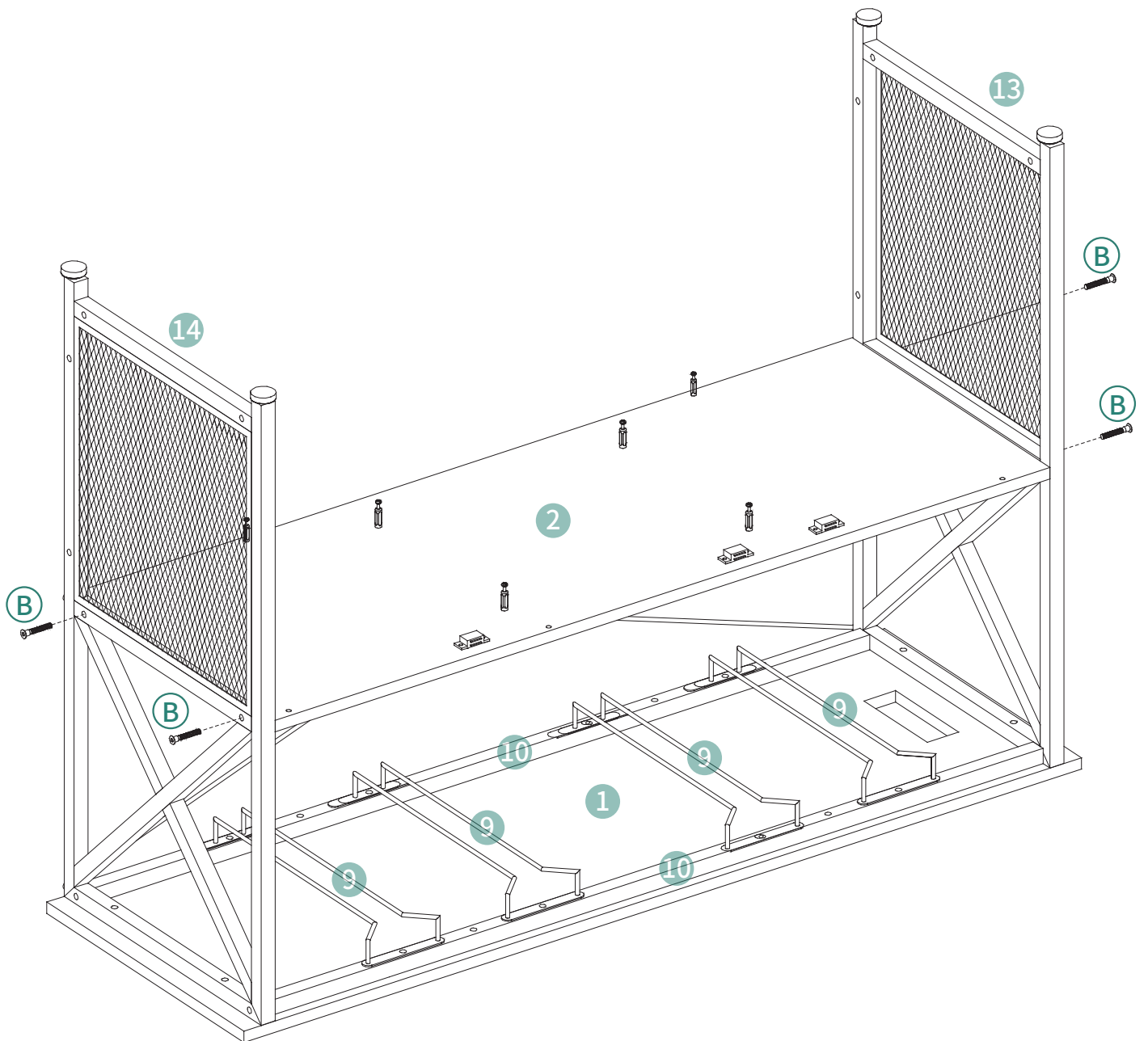
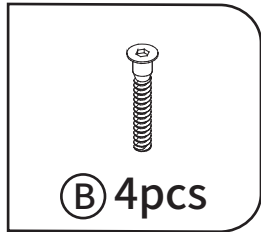

8

- ⑤ 1pc
- ⑥ 1pc
- ⑩ 4pcs

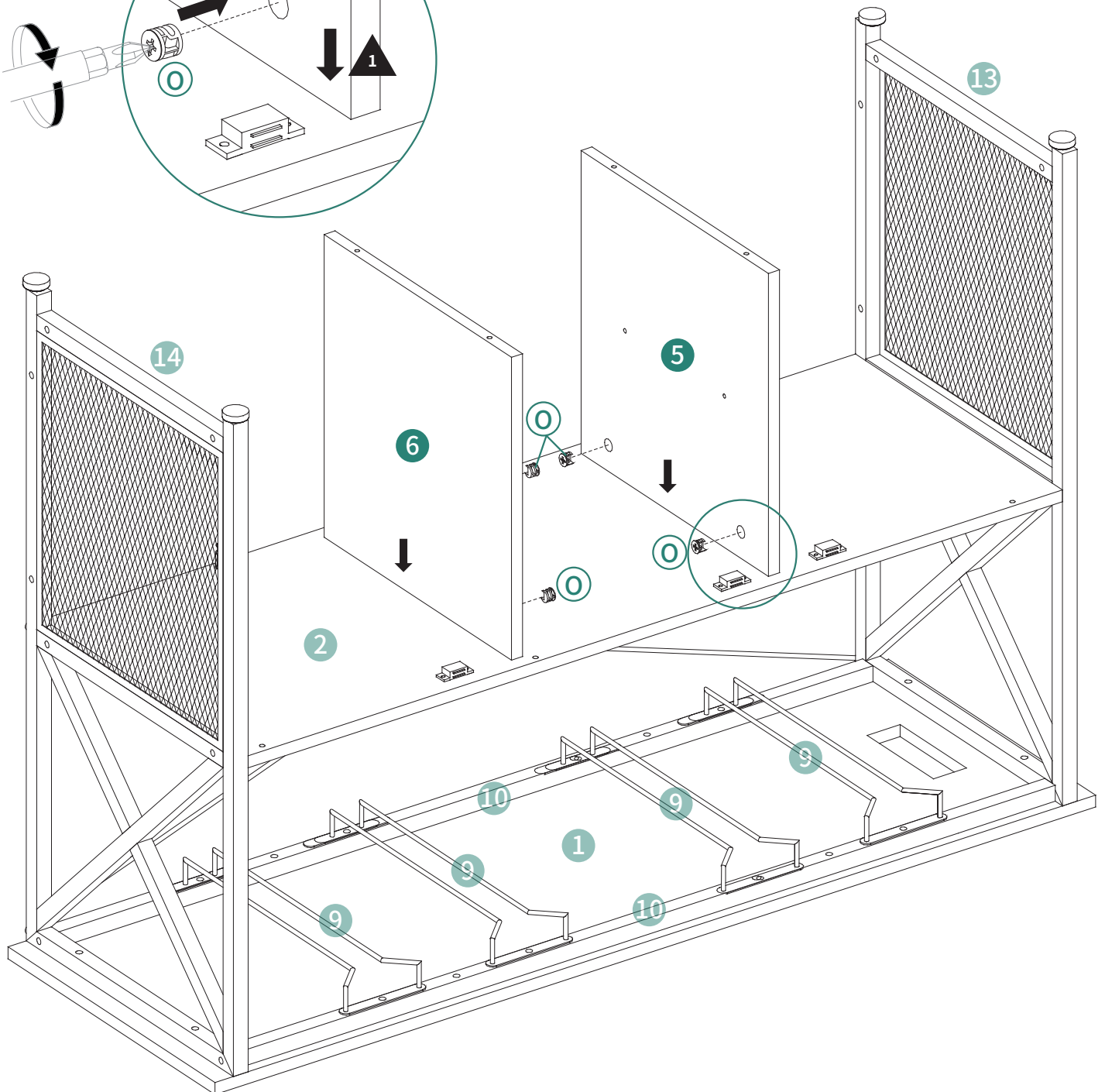
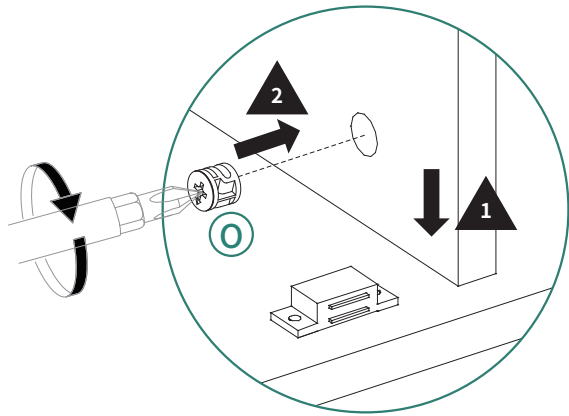

9

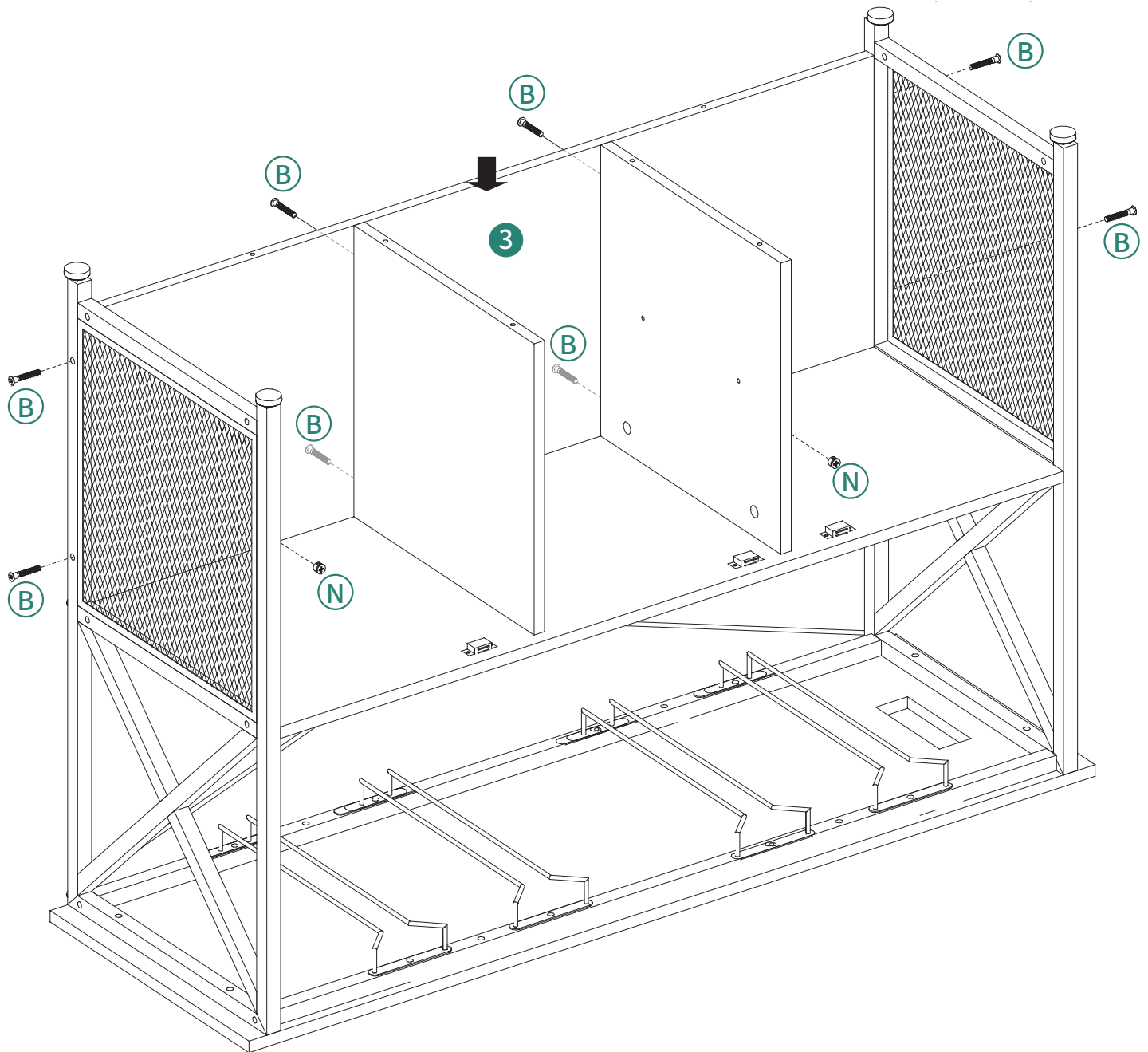
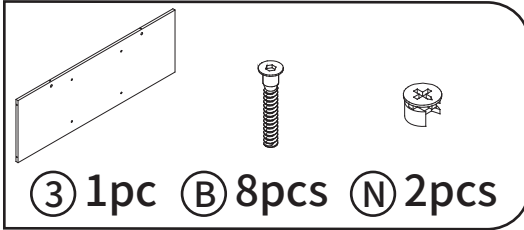

10

X3

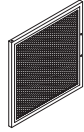

⑫ 3pcs



ⓓ 6pcs

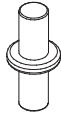

ⓔ 6pcs



Ⓚ 3pcs

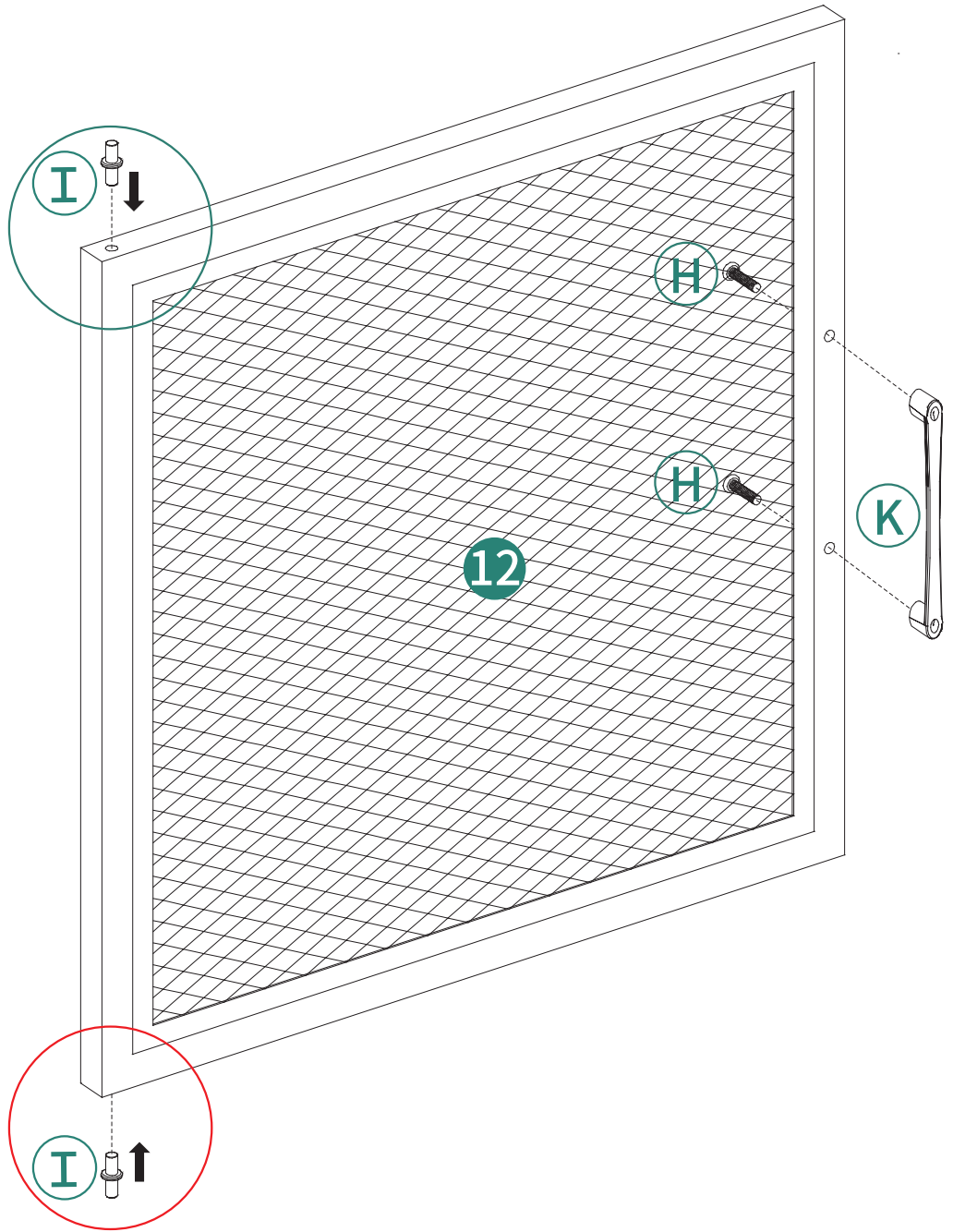
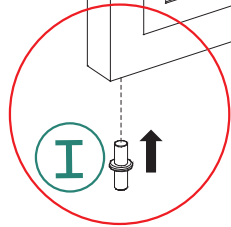
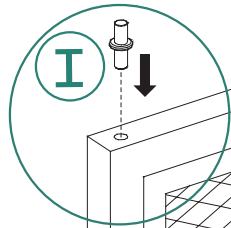
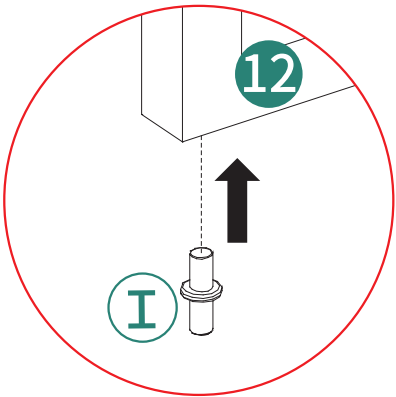
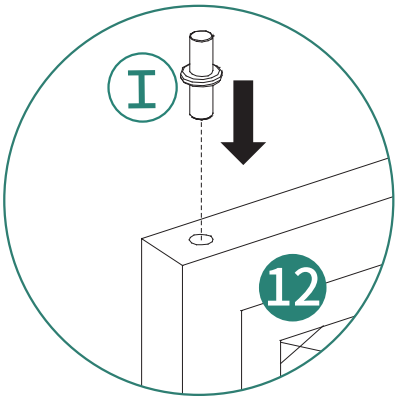

11

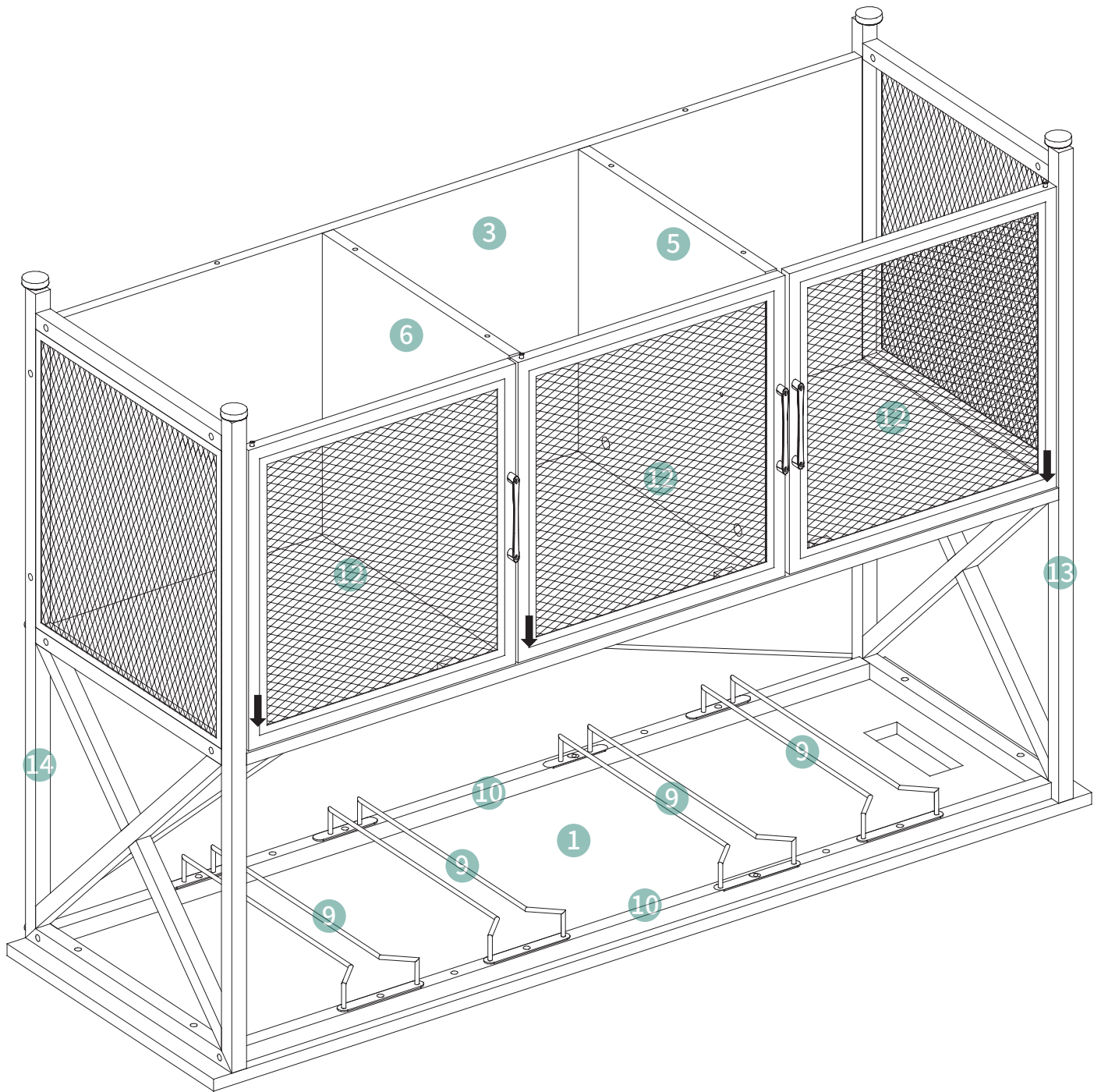

12

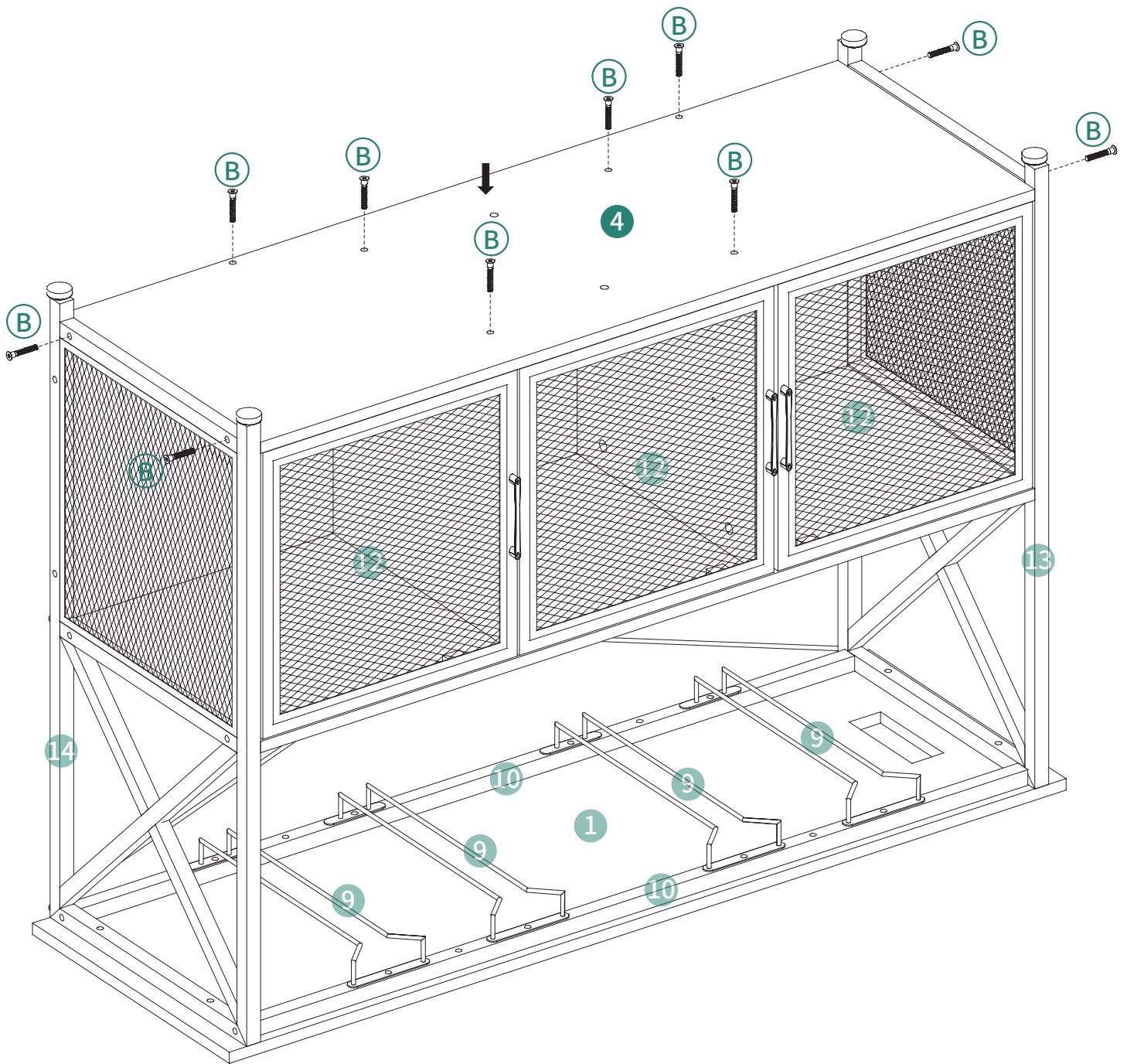
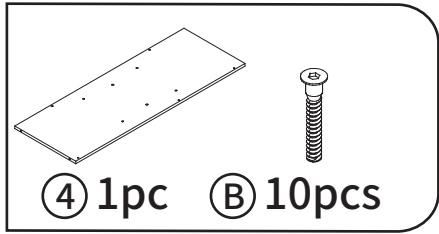

13

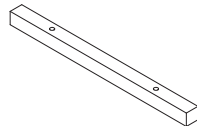

⑧ 1pc



Ⓐ 2pcs



Ⓓ 2pcs

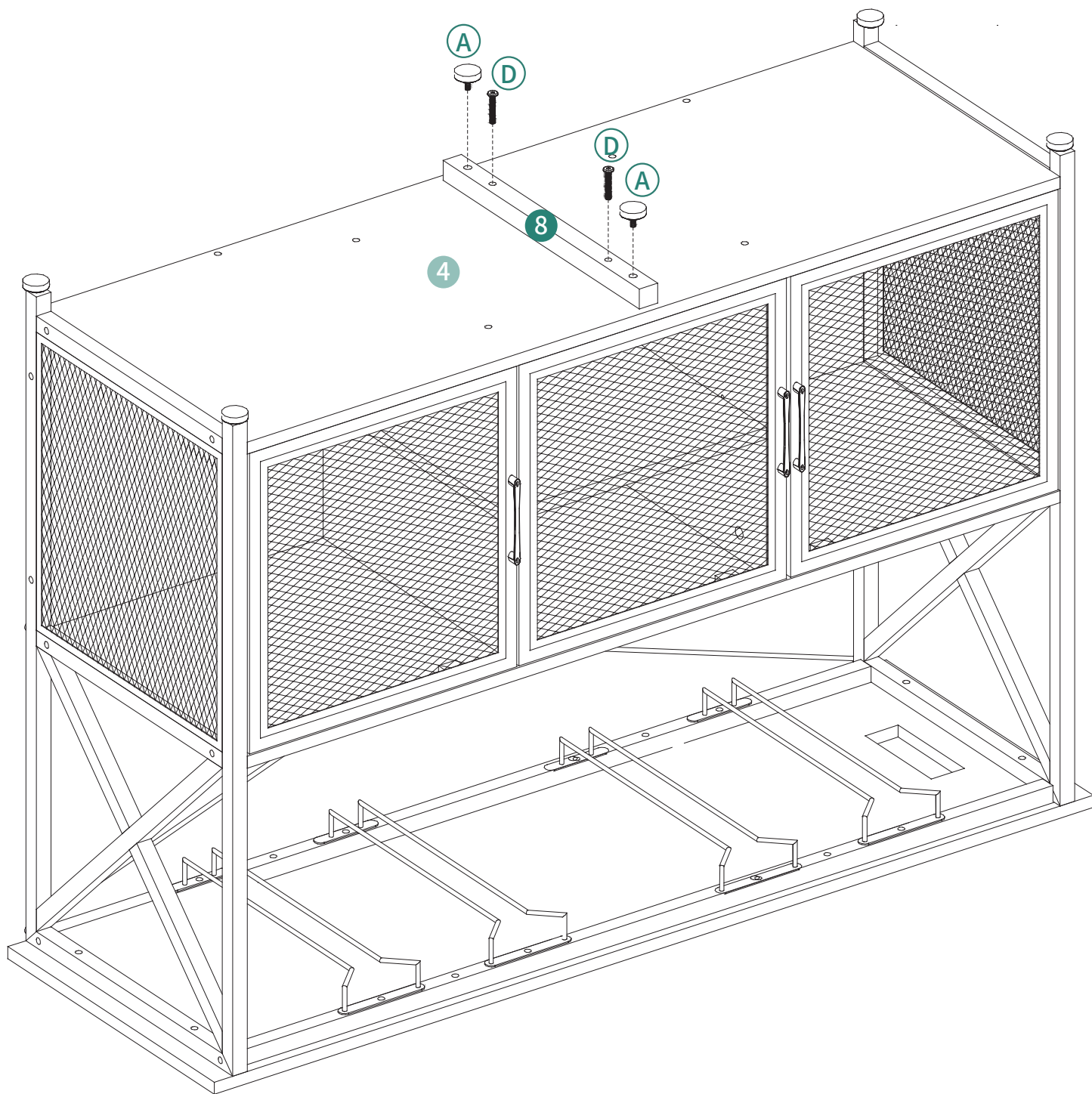

14

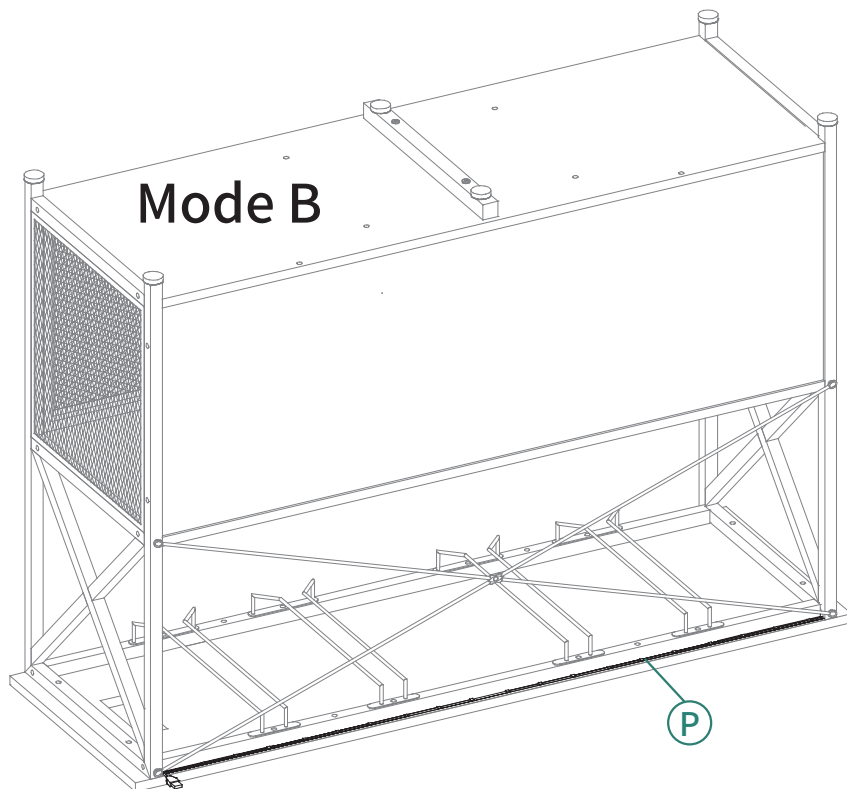
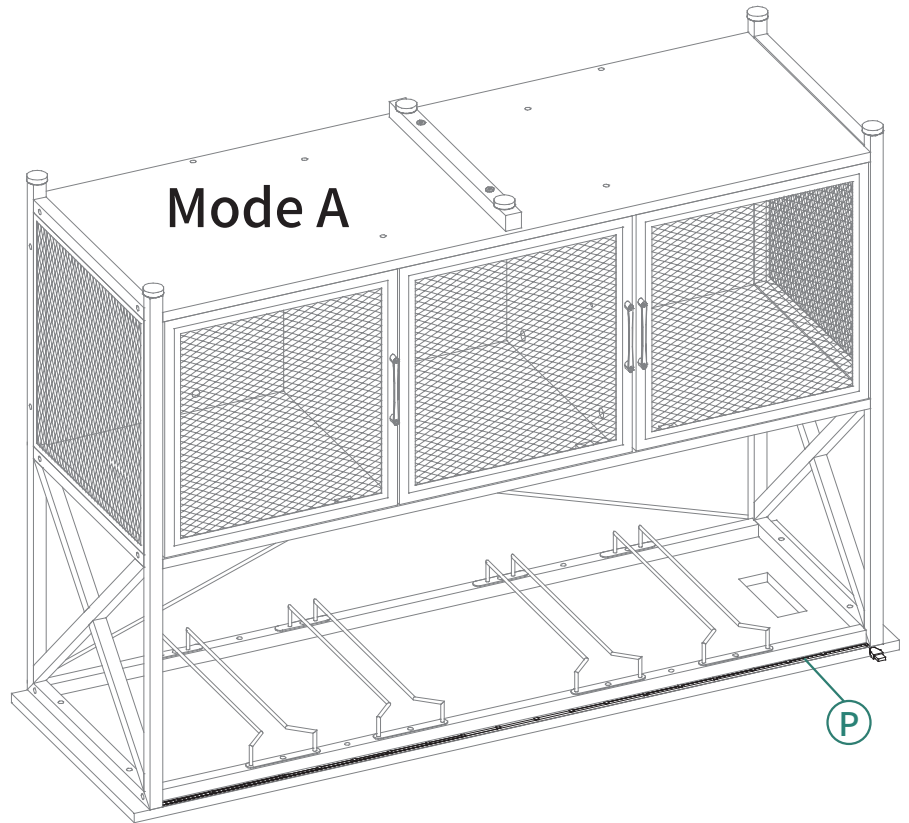
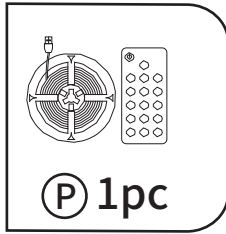

Choose the installation position of the light strip according to your actual needs.

Wählen Sie die Installationsposition des Lichtstreifens entsprechend Ihren tatsächlichen Bedürfnissen.

Choisissez la position d'installation de la bande lumineuse en fonction de vos besoins réels.

Scegli la posizione di installazione della striscia luminosa in base alle tue esigenze effettive.

Elija la posición de instalación de la tira de luz de acuerdo a sus necesidades reales.

15

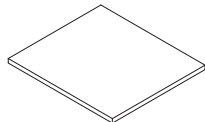

⑦ 1pc

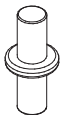

ⓐ 4pcs

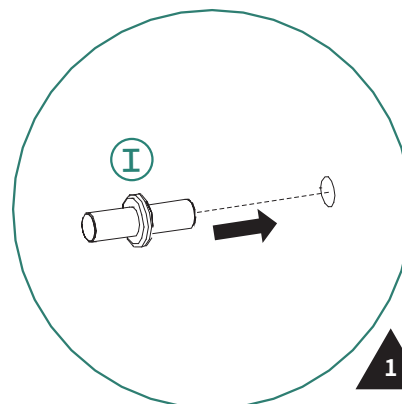
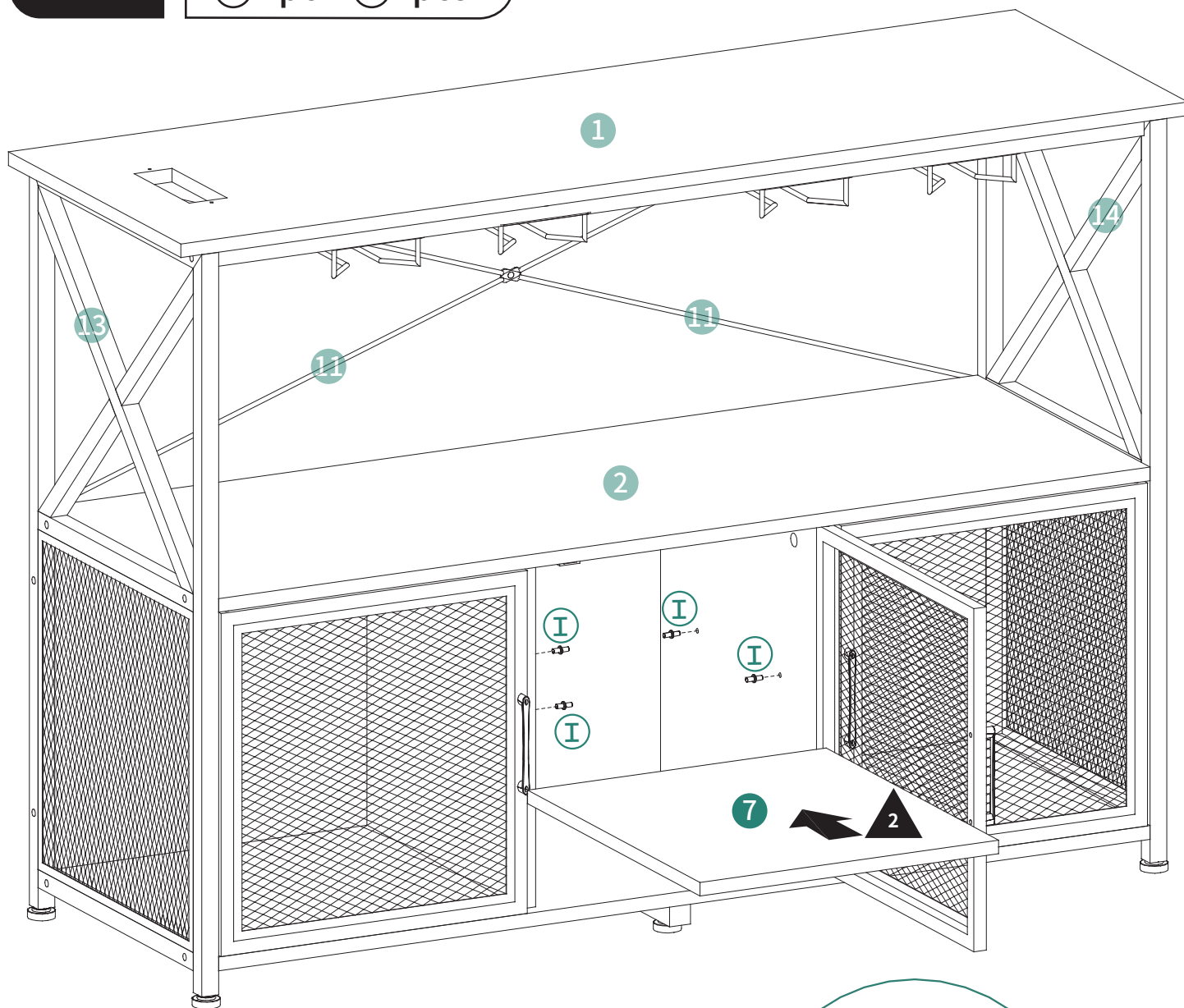

16

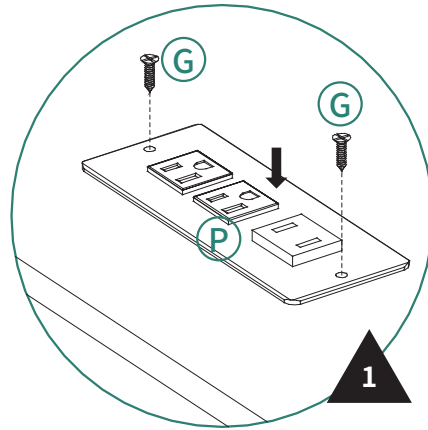
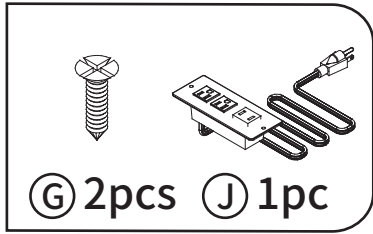

Not included
Nicht enthalten
Non inclus
Non incluso
No incluido

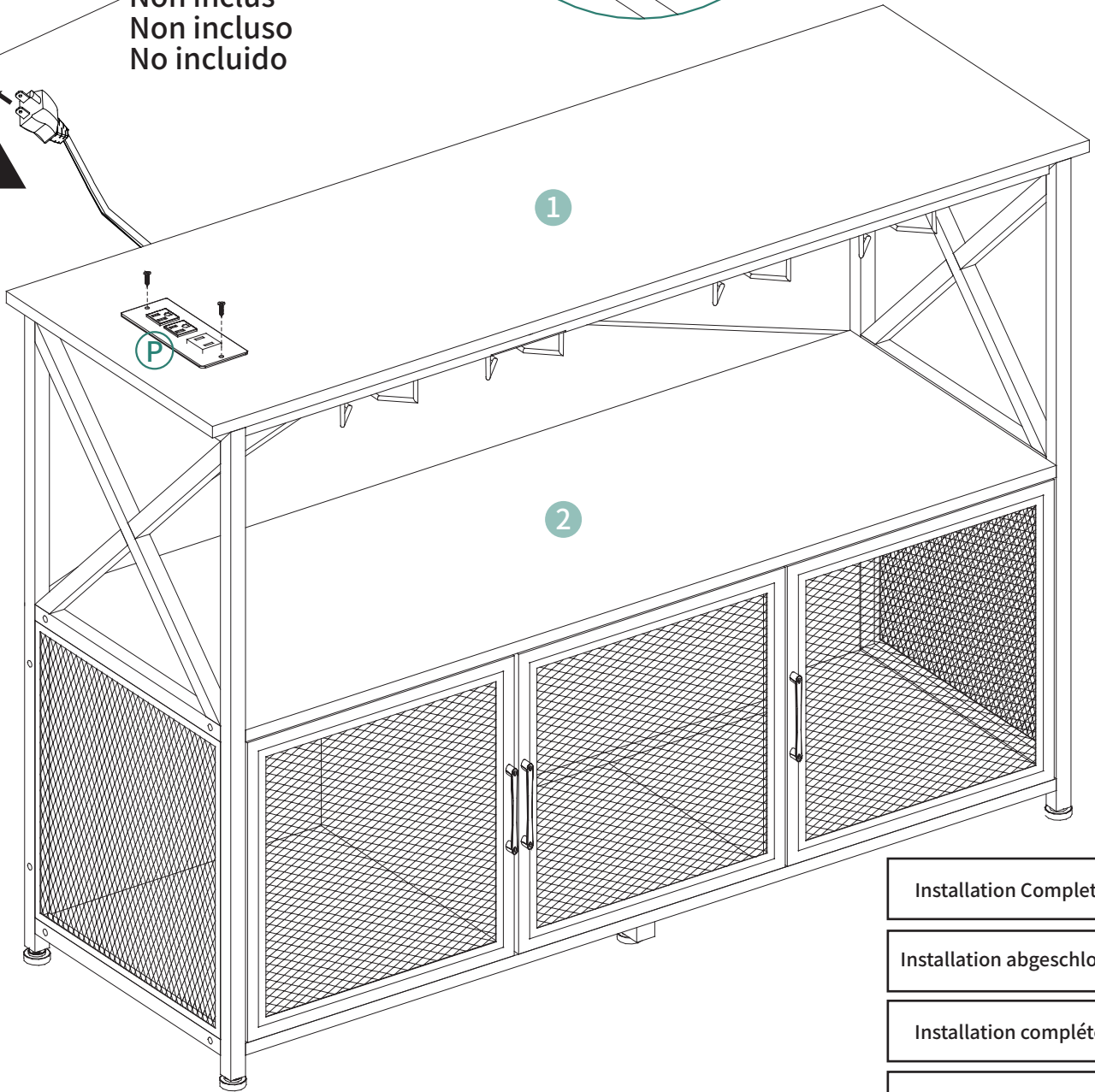
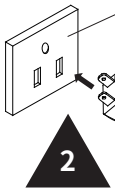

- Installation Completed
- Installation abgeschlossen
- Installation complétée
- Installazione completata
- Instalación completada