

PRODUCT MANUAL

ATTENTION! PLEASE READ THESE INSTRUCTIONS BEFORE USING THIS DEVICE

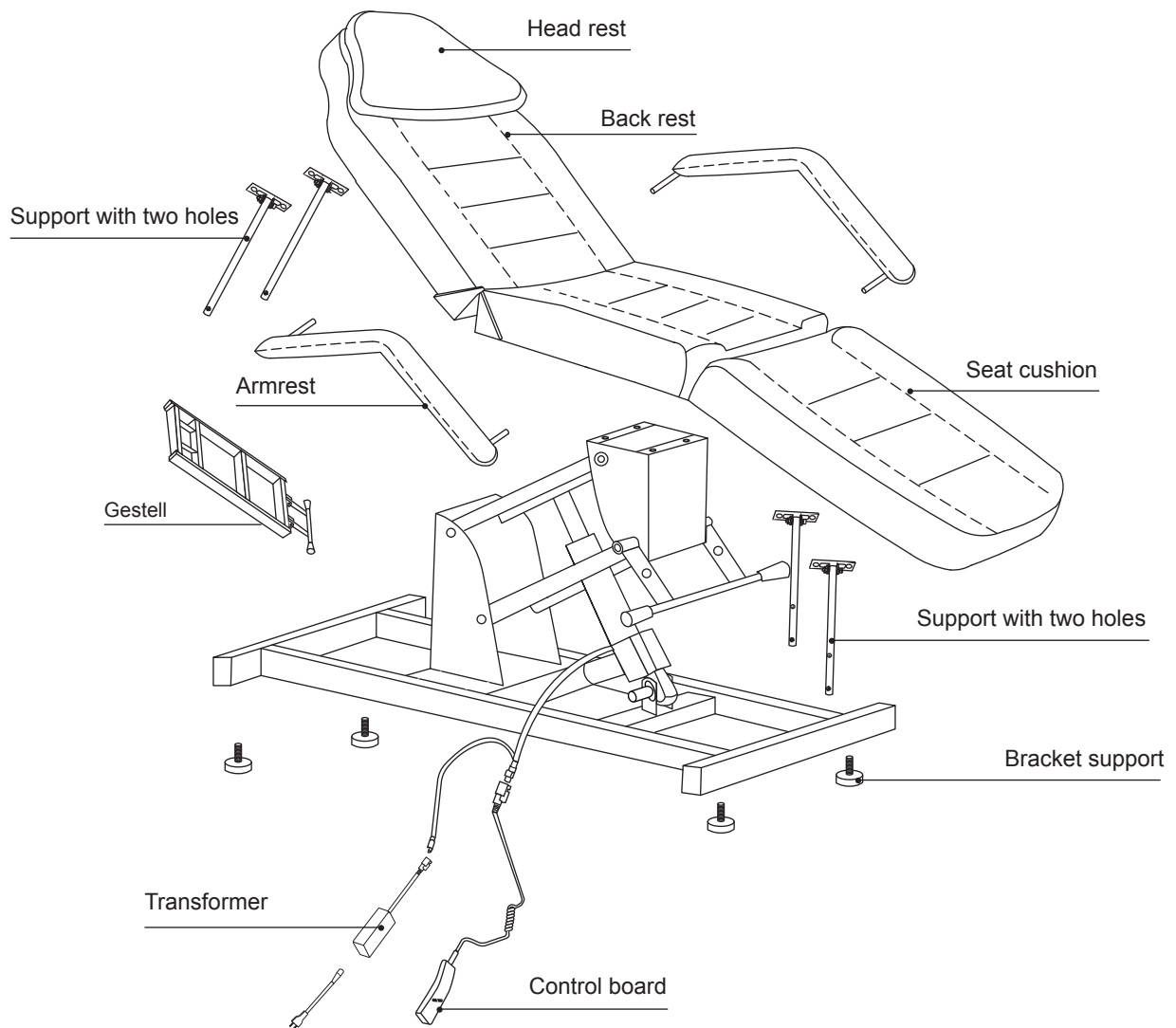

NOTICE:

If your package is missing parts or you are having issues with assembly, please call us directly.

Our customer service team will address any questions or concerns you may have. Have this manual open and ready for reference.

SAFETY:





To reduce risk of injury when assembling & using the bed, follow these precautions:

Read all of these instructions before assembling and using your salon bed.

Do not over-extend the chair (0-350lbs), creating the risk of falls or tipping the chair, and its occupant over, resulting in injury

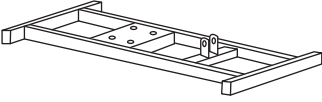
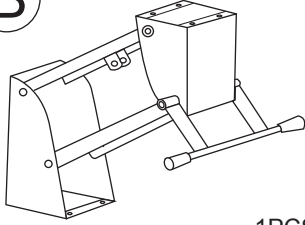
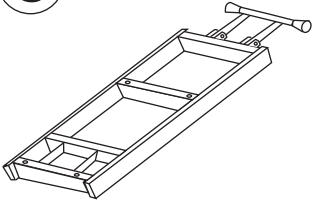
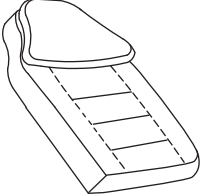
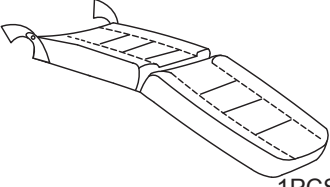
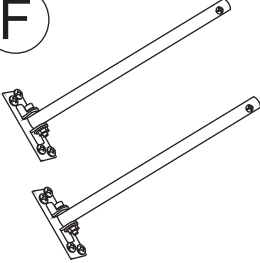
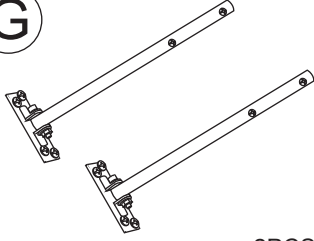
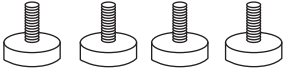
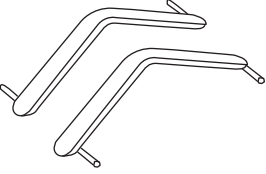
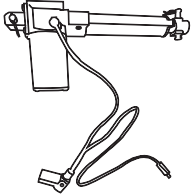
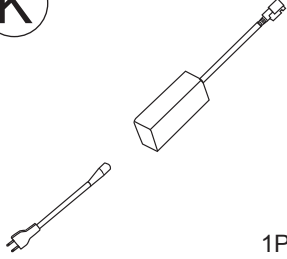
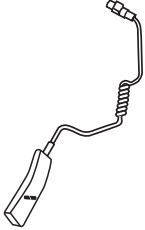
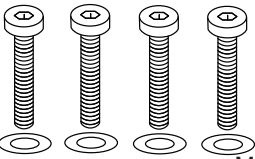
Please seat on the seat cushion instead of the backrest part as the weight may cause the break of the metal connection.

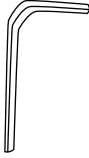
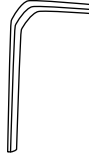
PART LIST

<p>A</p>  <p>1PCS</p> <p>Lower Bracket</p>	<p>B</p>  <p>1PCS</p> <p>Push Rod Support</p>	<p>C</p>  <p>1PCS</p> <p>Upper Bracket</p>	<p>D</p>  <p>1PCS</p> <p>Backrest</p>
<p>E</p>  <p>1PCS</p> <p>Seat cushion</p>	<p>F</p>  <p>2PCS</p> <p>Backrest Metal Bar</p>	<p>G</p>  <p>2PCS</p> <p>Leg rest Metal Bar</p>	<p>H</p>  <p>4PCS</p> <p>Bracket Support</p>
<p>I</p>  <p>2PCS</p> <p>Hand rest</p>	<p>J</p>  <p>1PCS</p> <p>Push Rod</p>	<p>K</p>  <p>1PCS</p> <p>Transformer</p>	<p>L</p>  <p>1PCS</p> <p>Control Board</p>
<p>M</p>  <p>M8x70 4PCS</p>	<p>N</p>  <p>M10*20 8PCS</p>	<p>O</p>  <p>M8 1PCS</p>	<p>P</p>  <p>M10 1PCS</p>
<p>Q</p>  <p>M12+M14 1PCS</p>			

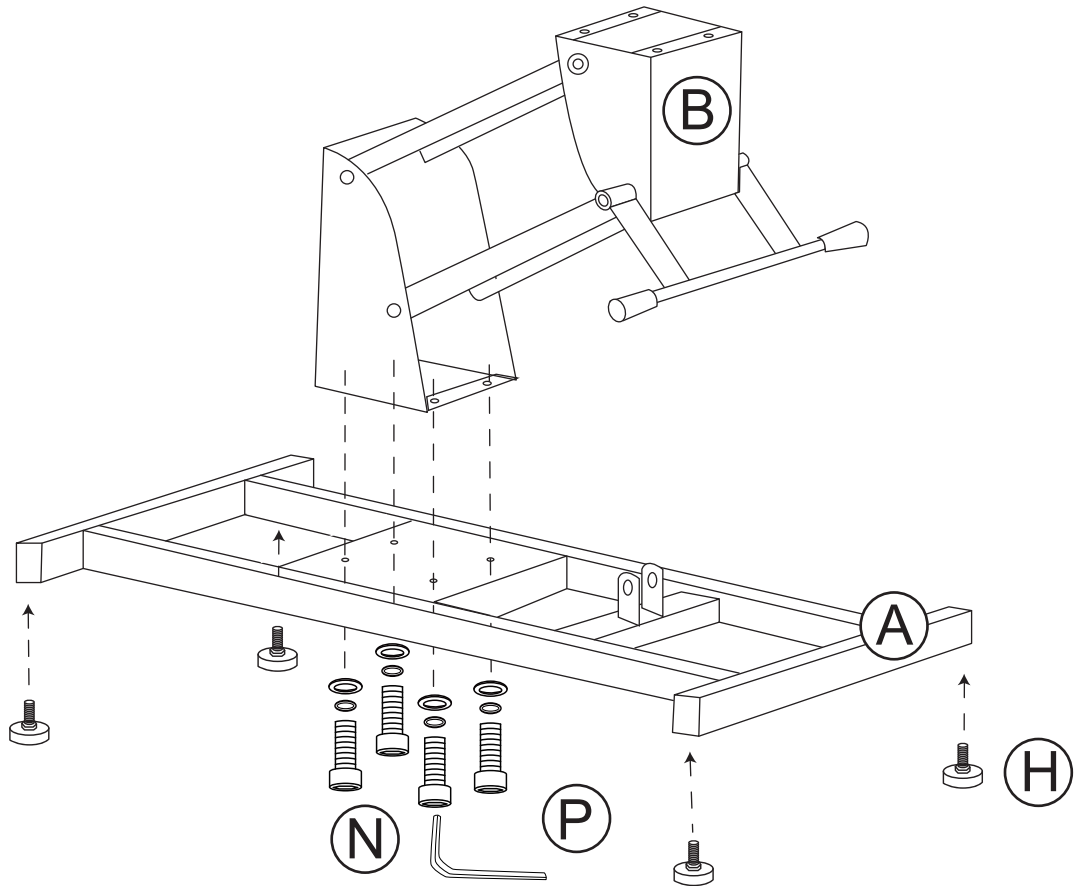
1

First, screw the 4 bracket supports(#H) with 4 holes of the bracket(#A) and tighten them.
Then use screws(#N) to connect the push rod support(#B) to the bracket(#A).

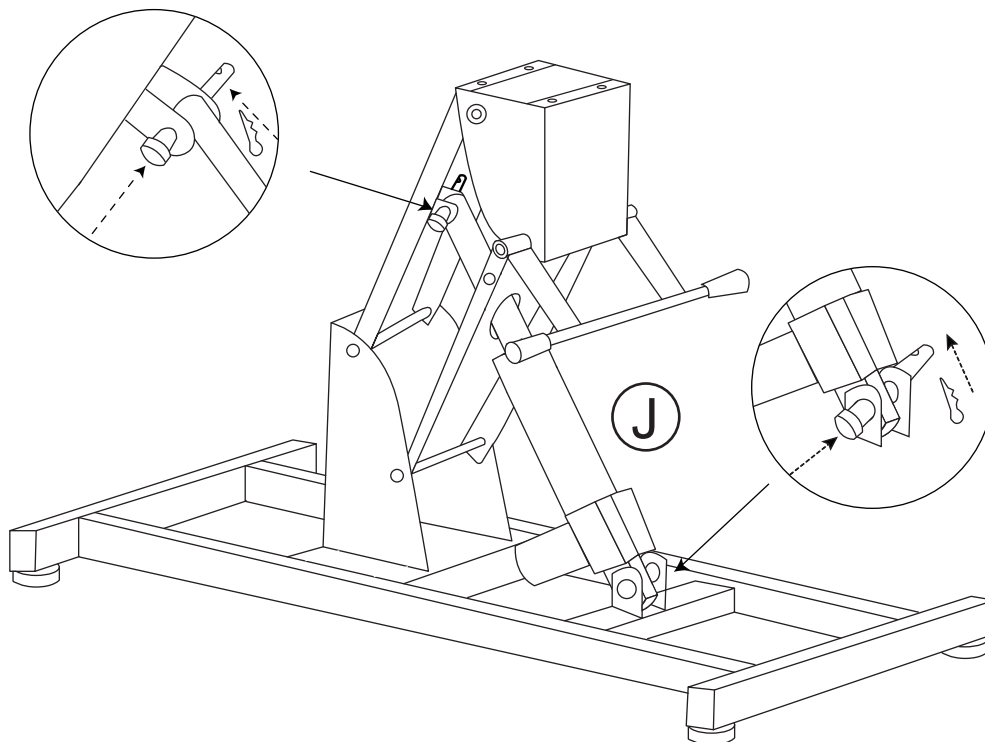
2

Screw off the prefixed dowel pins on the motor. Then use the prefixed dowel pins to assemble the motor.

3

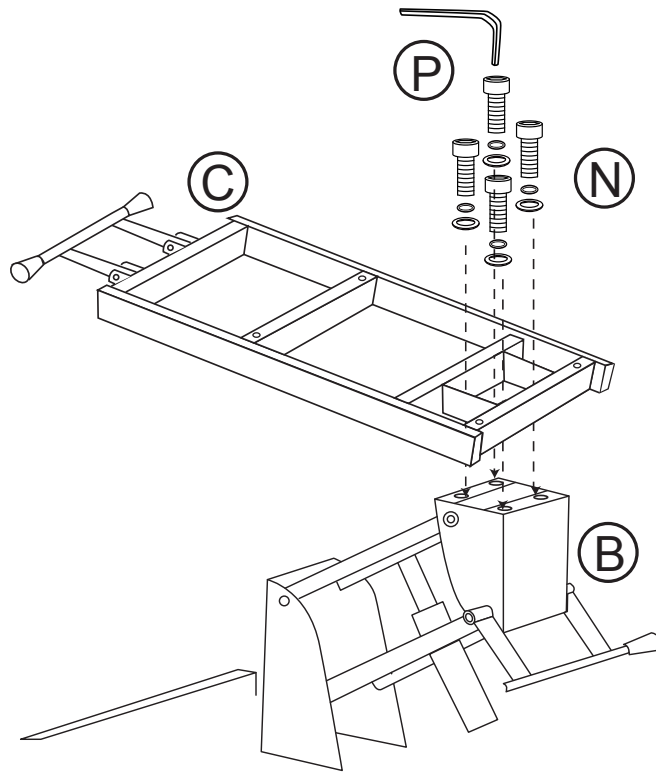

Fix the Bracket(#C) to the Push Rod Holder(#B) with screws (#N).

4

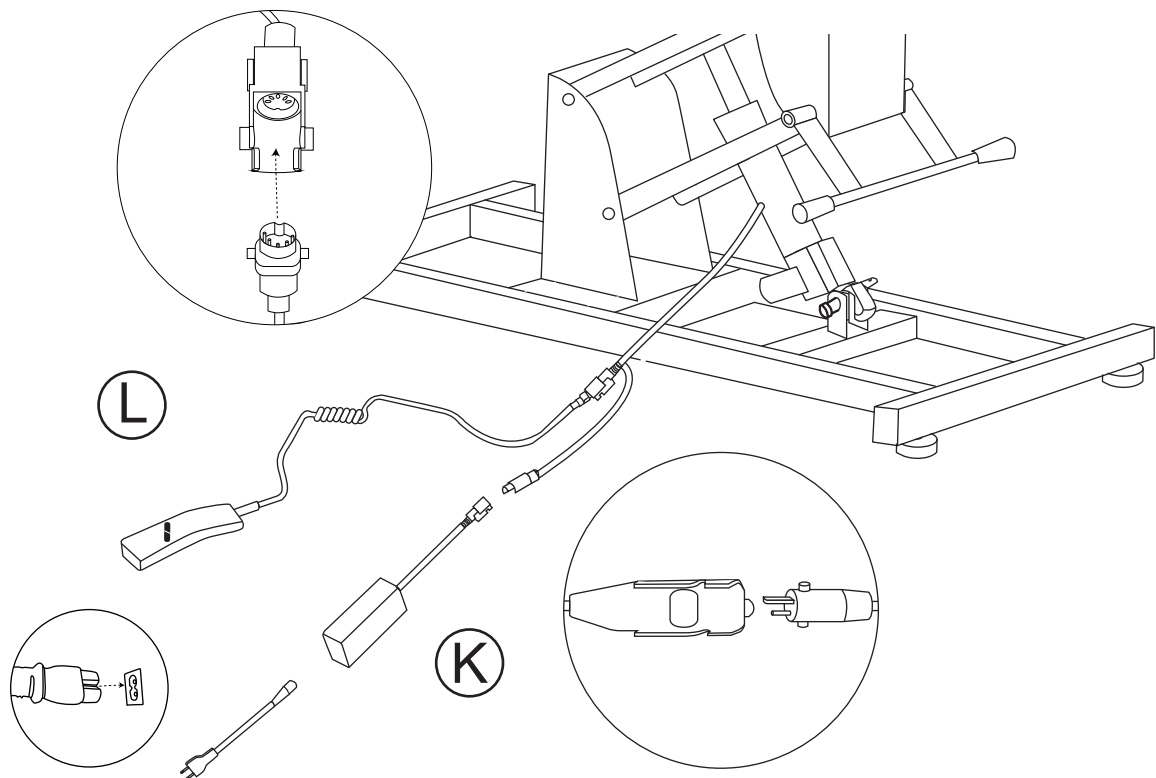

Assemble the transformer(#K) & control board(#L) to the push rod. Please see the diagram in detail.

5

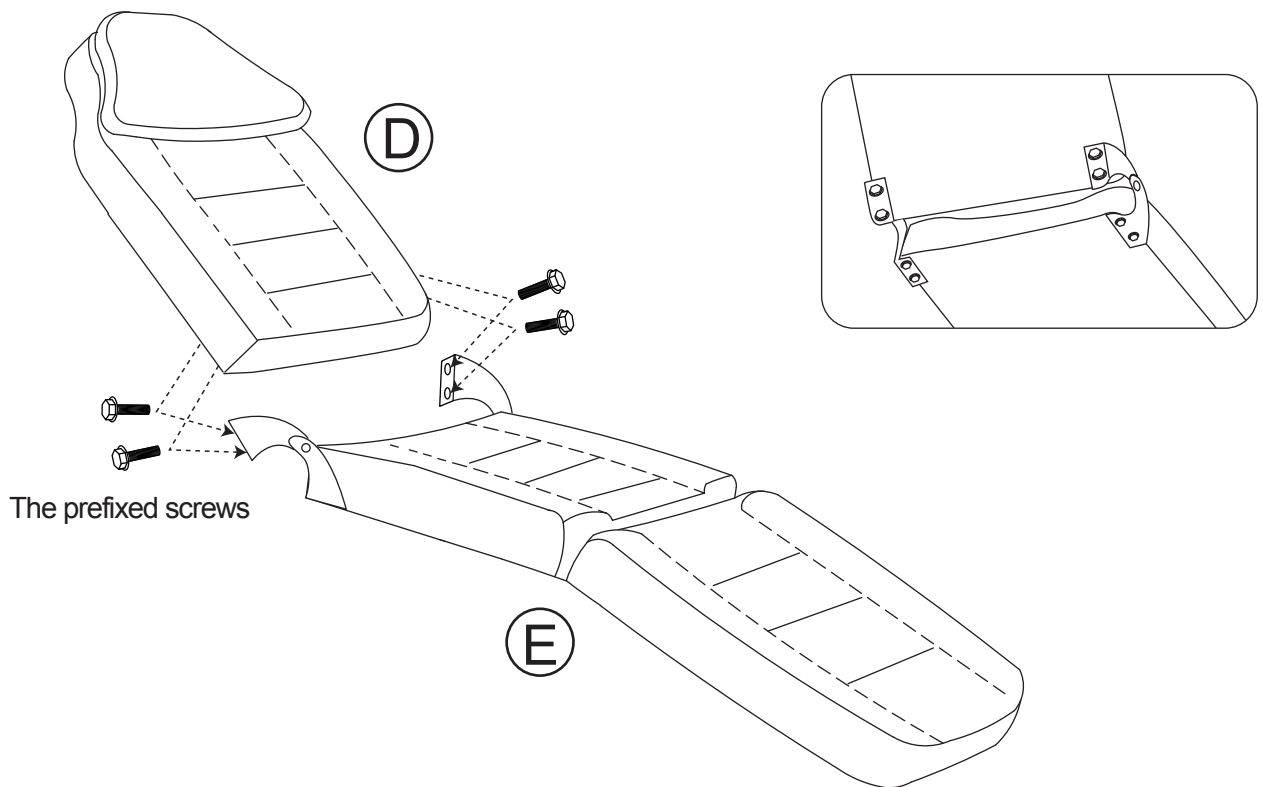

Remove 4 bolts prefixed on the backrest and match the metal joining parts of seat cushion to 4 holes on the backrest, then use 4 bolts to connect.

6

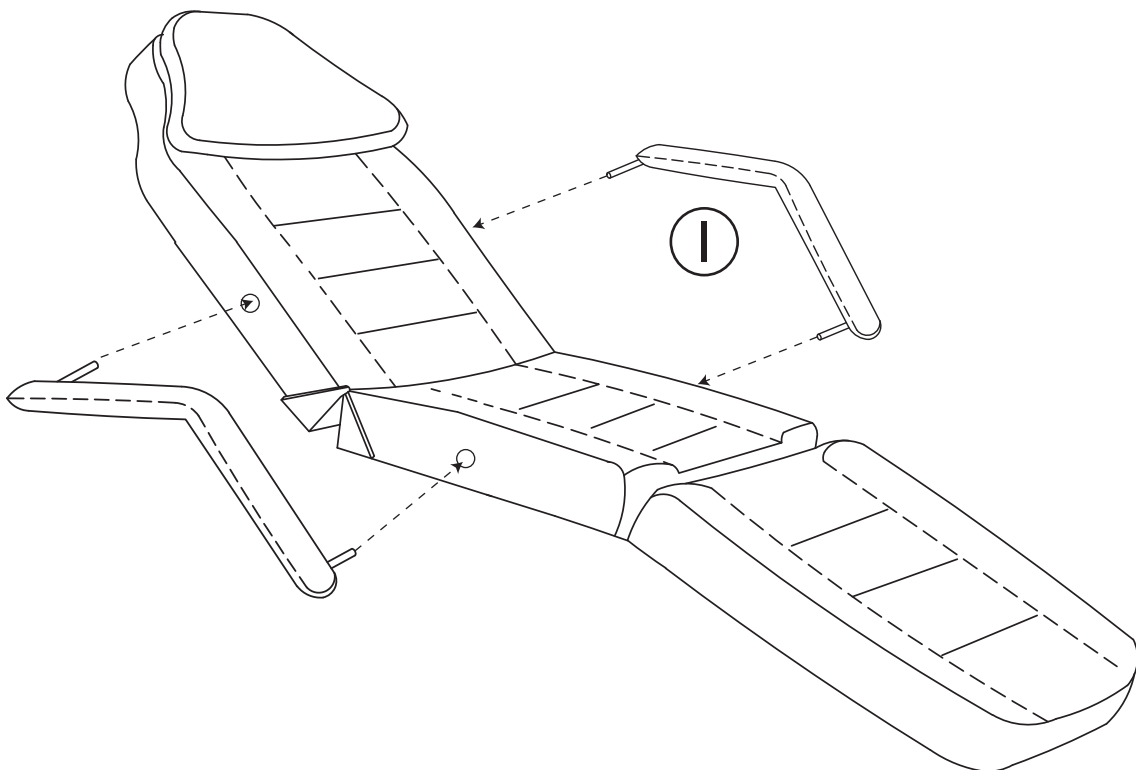

Put the installed cushions up right and insert two hand rests(#1) into the holes on each side.

7

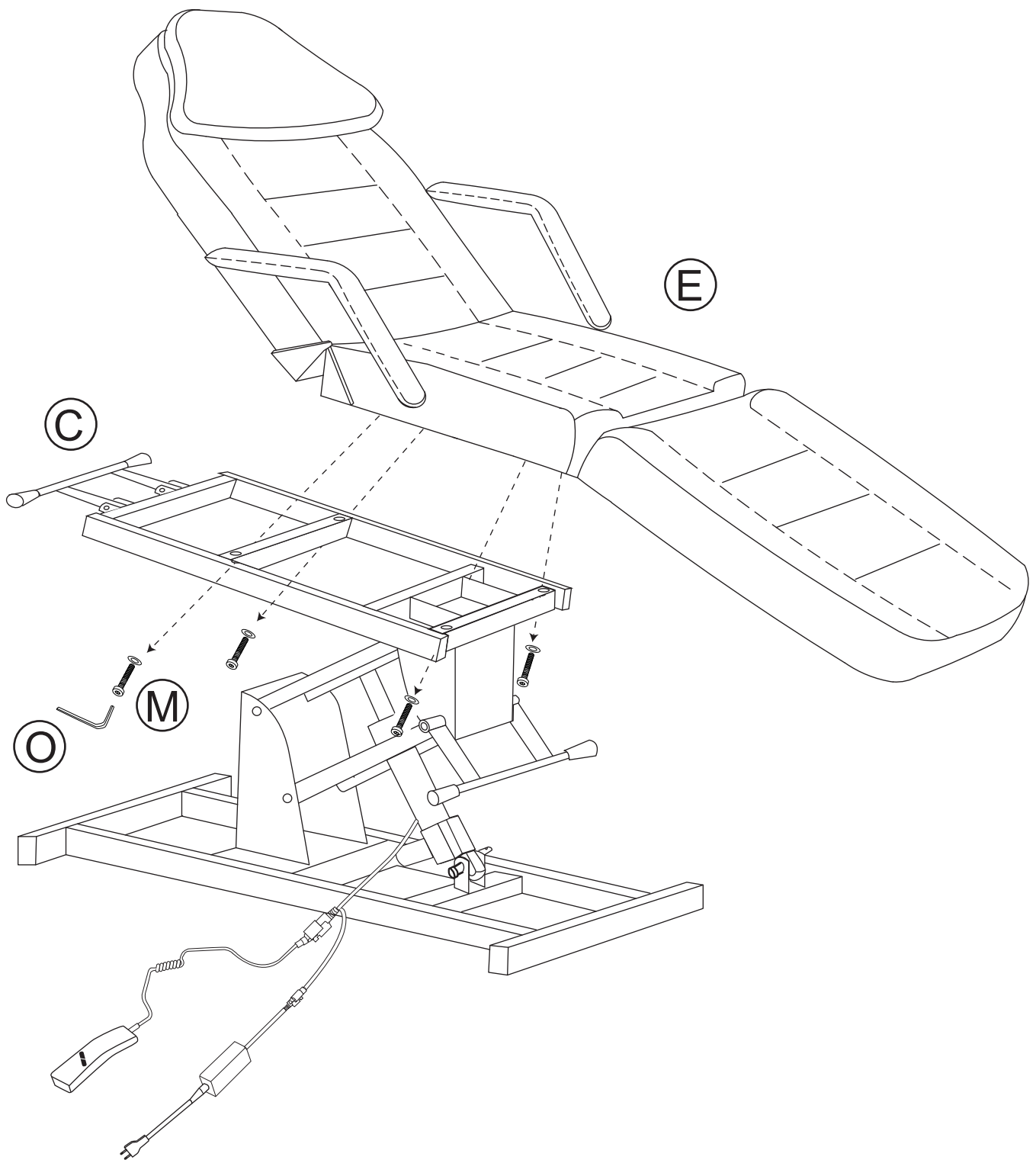

Fix the seat cushion (#E) to the frame II (#C) with screws (#M).

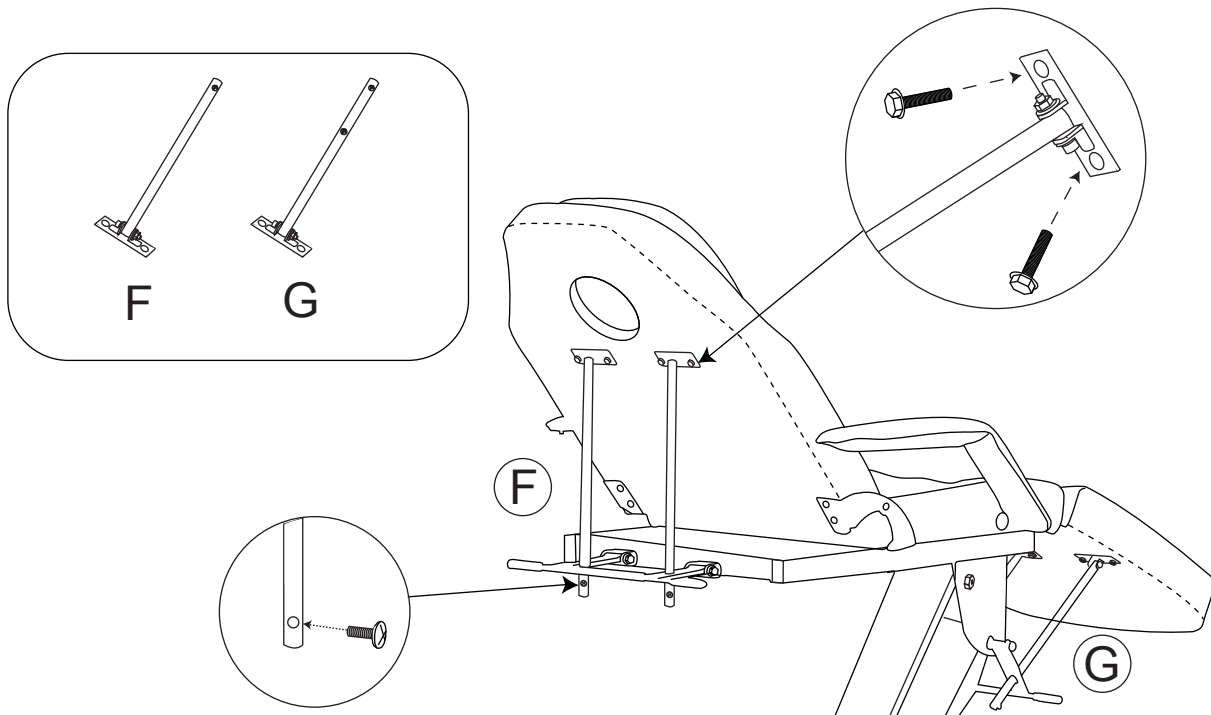

First, remove the screws prefixed connecting the metal parts to (#F). Second, remove the screws prefixed on the backrest and then use them to assemble the metal parts to the backrest. Third, insert the bars through the U-bar and use the screws you removed at the first step to assemble (#F) to the metal part.

9

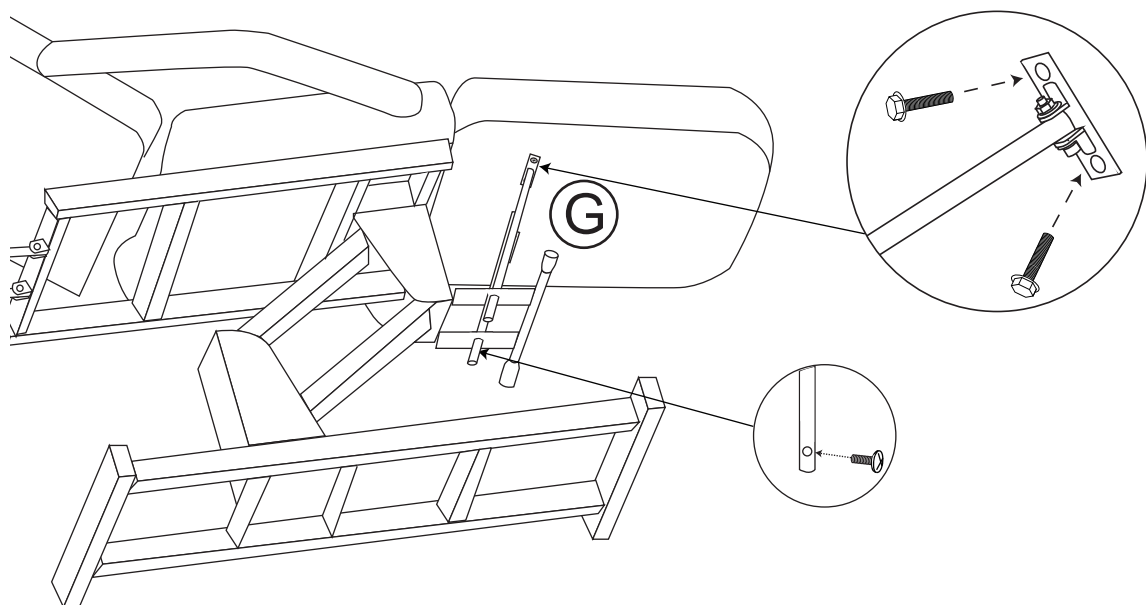

First, remove the screws prefixed connecting the metal parts to (#G). Second, remove the screws prefixed on the leg rest and then use them to assemble the metal parts to the leg rest. Third, remove the screws prefixed at the middle of the bars (#G) and then insert the bars through the U-bar and use the screws you remove at the first step to assemble (#G) to the metal part.

10

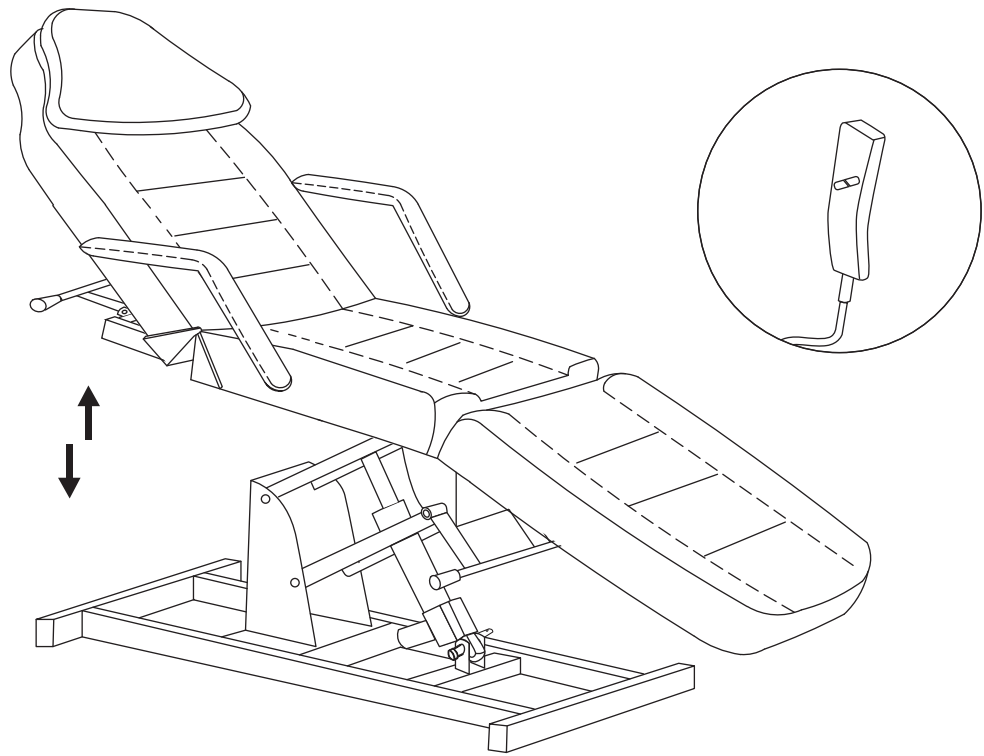

Connect power plug to power, press the up button to raise and down button to lower.

Attention: Do not over-extend the chair(0-350lbs), creating the risk of falls or tipping the chair and its occupant over, resulting in injury.

11

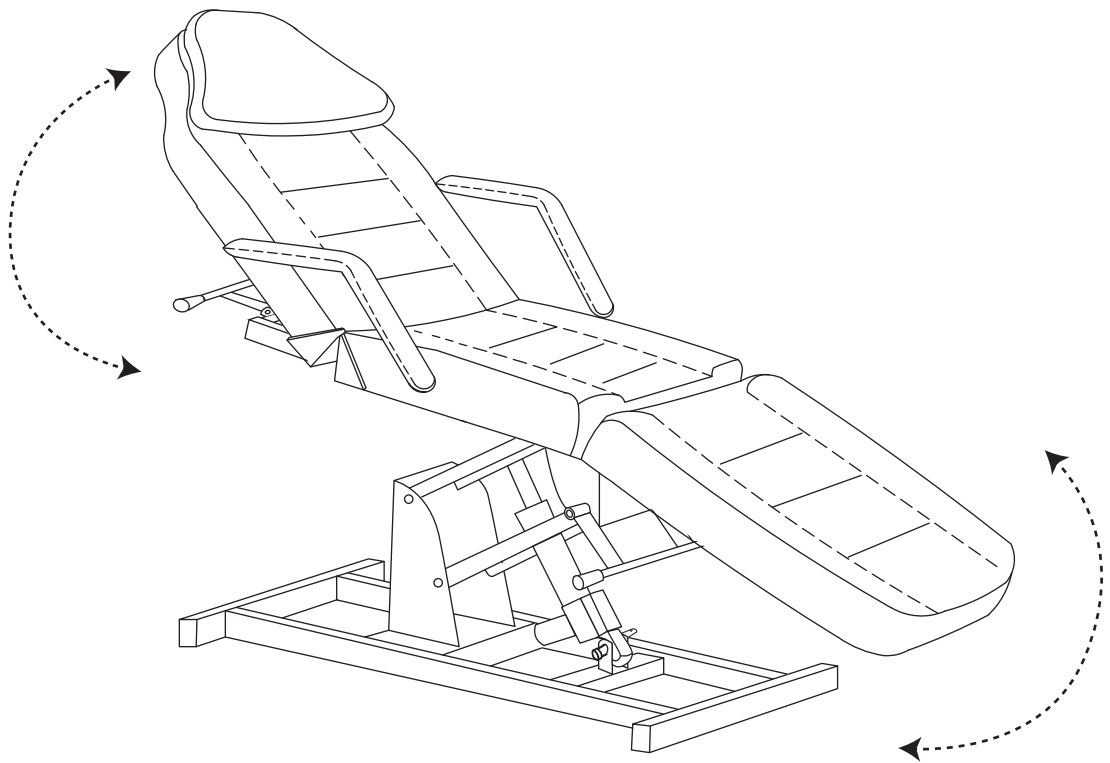

Adjust the U-bar and backrest support to up or down the Backrest. Adjust the U-bar and leg rest support to up or down the Leg rest.

Surface Maintenance Recommendation

1. Avoid using hard objects to scratch the chair surface. The leather fabric is wear-resistant, but it is easy to be scratched by hard objects. The sharp items such as scissors and razors used in the hair salon need to be placed properly. In addition, guests' zippers, and buttons may scratched the leather surface of the Massage Bed.

2. The leather surface material needs regular care. You can use the leather surface curing agent to spray and wipe the surface of the bed from time to time for maintenance. If the bed surface is stained with dyes, perm agents and other difficult-to-clean items , please wipe it off immediately to avoid from surface staining.

Common problems and solutions

1. Leg rests and backrest slide slowly: Please remove the U-bar first, then turn it upside down and reinstall it to resolve the issue.
2. The leg bracket screw holes are not aligned: Please loosen the pre-installed screws, then adjust the metal gasket position until the holes are completely exposed, and then tighten the screws again to solve the problem.

Limitations Applicable to All Warranties

All warranties are to the original purchaser.

We will replace the defective parts or send replacement chair provided that the warranty parts have not been subjected to misuse, abuse or improper service by the consumer, for example, damaged wire arising in consequence of negligence or improper operation.

Exclusions also include components with damage caused by:

- Contamination
- Abuse, misuse, accident, or negligence
- Commercial use, or use other than normal
- Improper operation, maintenance, or storage

We will pay standard shipping rates on all warranted parts for the first year. We can also sell you replacement part for discount price when your chair is out of warranty policy.