

Weight capacity: 200 kgs (440 Lbs)

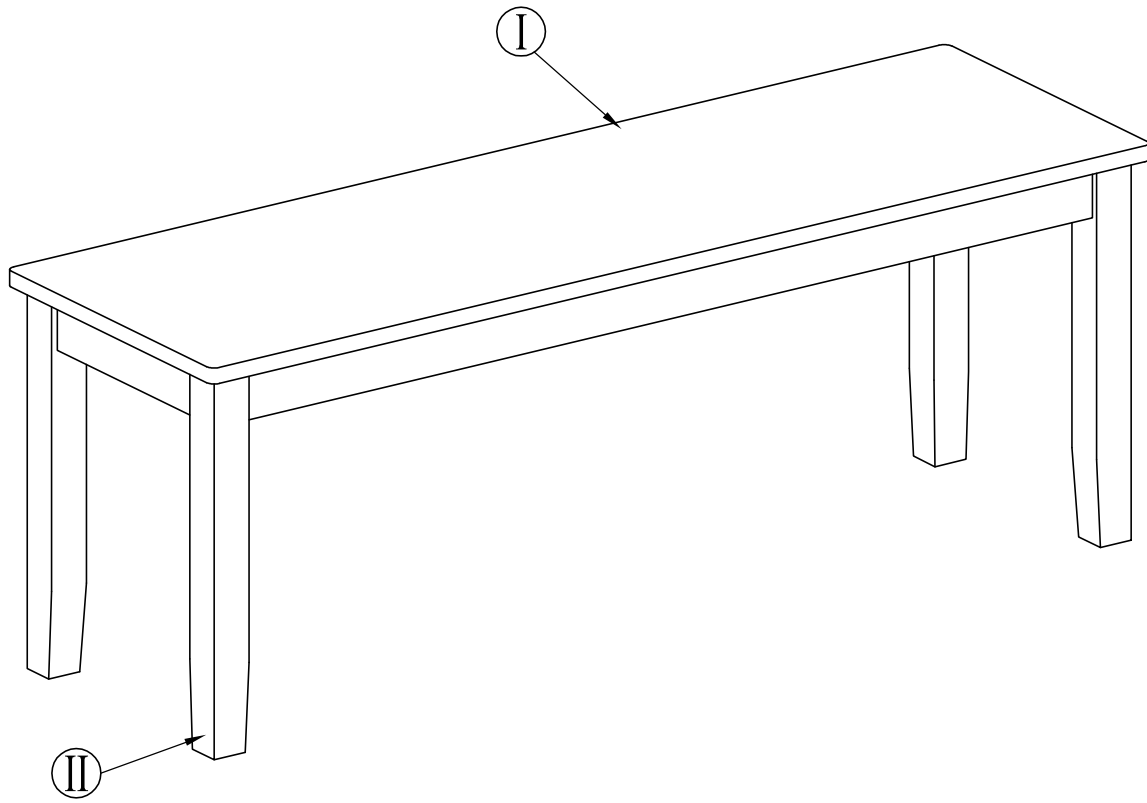



NOTE: 50% TIGHTEN BEFORE FIXING ALL BOLTS & SCREWS

COMPONENTS LIST

Ⓘ

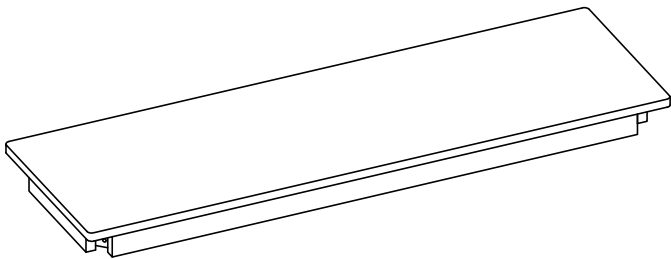



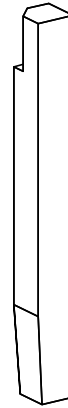

QTY 1

Ⓜ



QTY 4

HARDWARE LIST

A		8	F - Bolt 6 x 60	C		8	Washer
B		8	Washer	D		1	Allen Key

Step 1

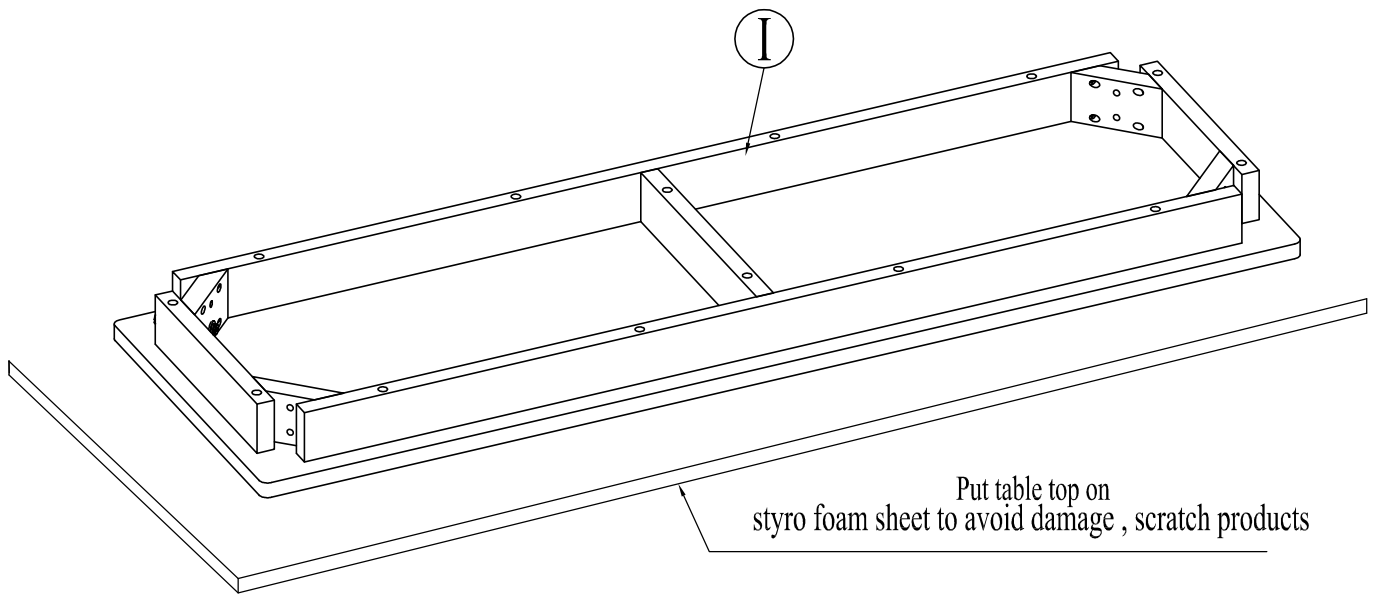

Step 2

Connect leg (II) with bench top by Bolt (A) , washer (B) & (C)

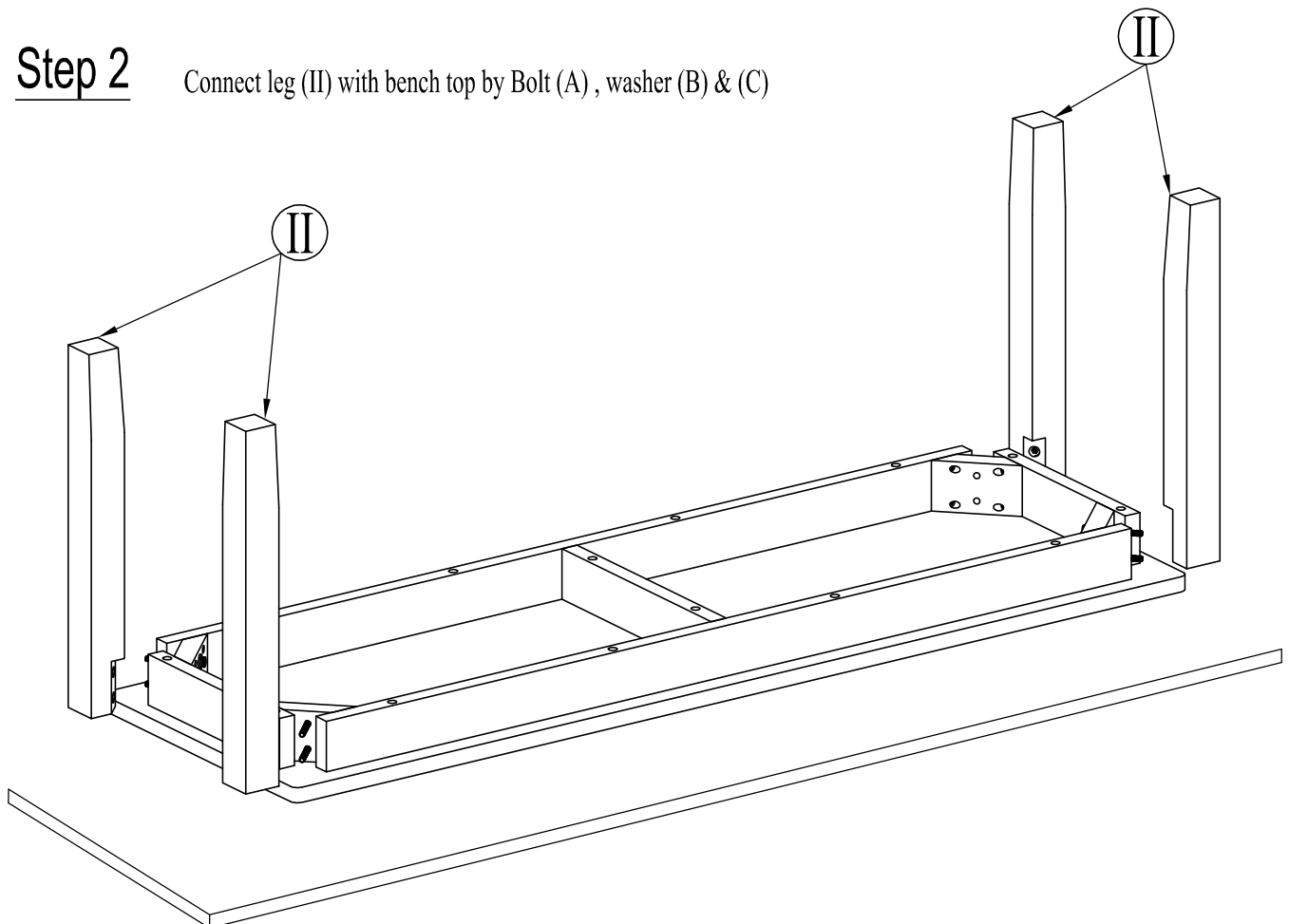

Step 3

Tighten all bolt (A) by allen key (D)

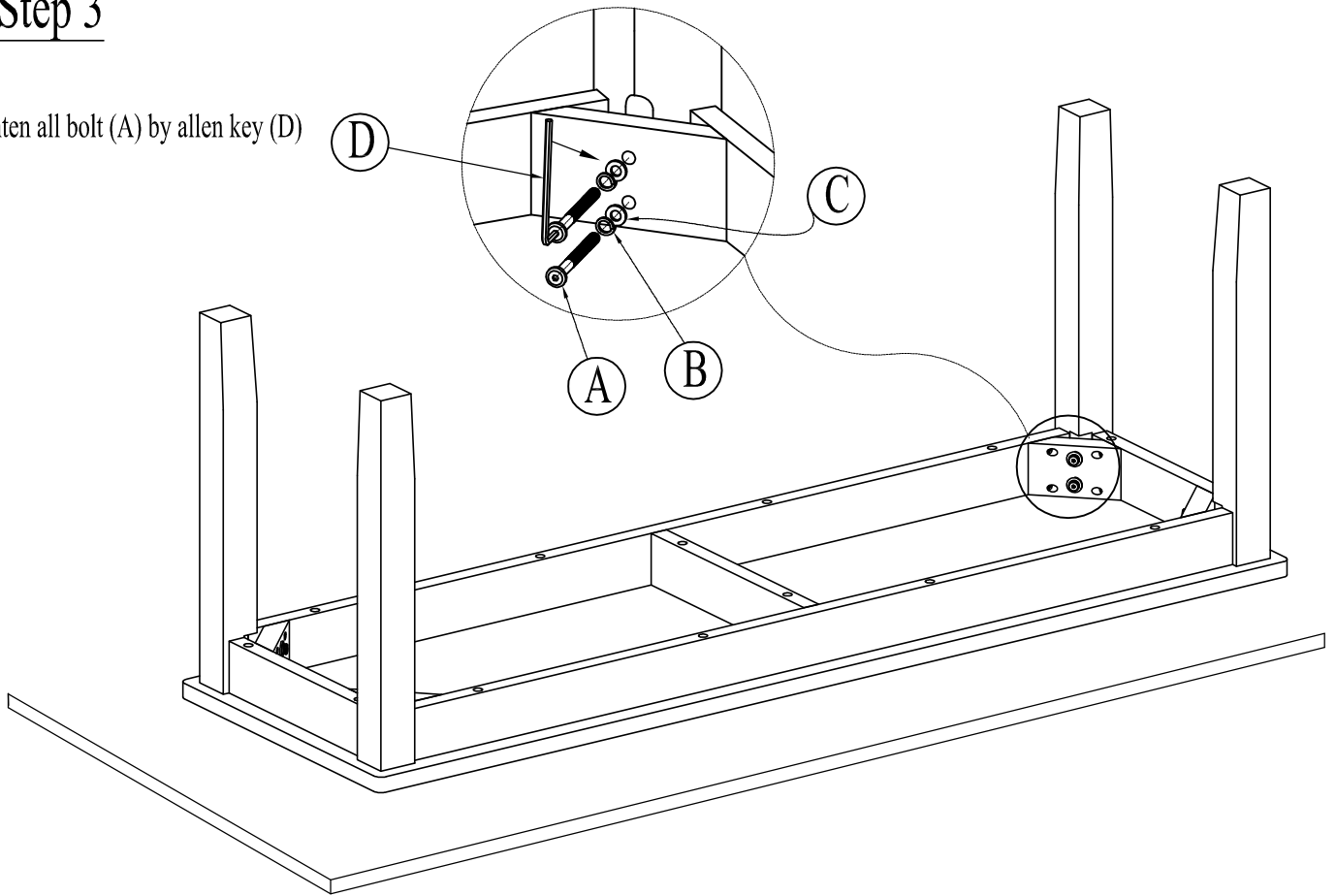

Step 4

FINISH !

