

VEVOR

Affordable. Reliable. Home Improvement.

CABINET STYLE GARMENT RACK

YC0009

VEVOR

Affordable. Reliable. Home Improvement.

CABINET STYLE GARMENT RACK

MODEL: YC0009

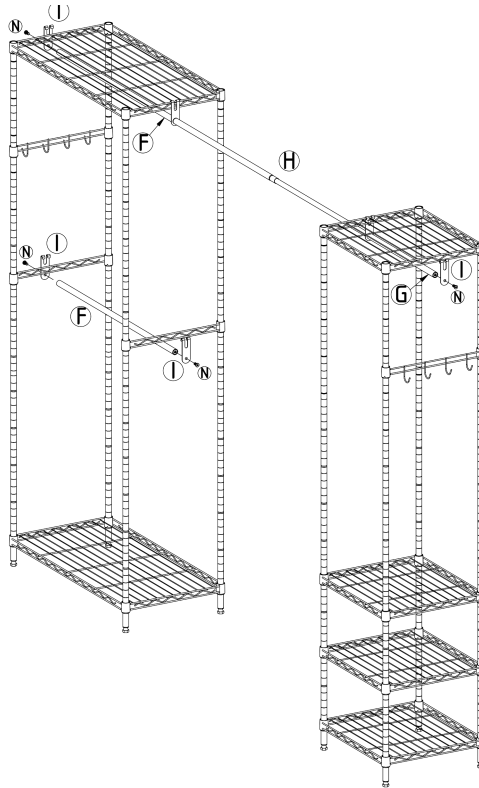

This is the original instruction, please read all manual instructions carefully before operating. VEVOR reserves a clear interpretation of our user manual. The appearance of the product shall be subject to the product you received. Please forgive us that we won't inform you again if there are any technology or software updates on our product.

SAFETY INSTRUCTIONS

WARNING:

Read this material before using this product. Failure to do so may result in serious injury.

Assembly precautions







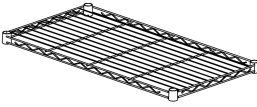

1. Assemble only according to these instructions. Improper assembly may create hazards.
2. Wear ANSI-approved safety goggles and heavy-duty work gloves during assembly.
3. Keep the assembly area clean and well-lit.
4. Keep bystanders out of the area during assembly.
5. Do not assemble if tired or when under the influence of alcohol, drugs or medication.
6. The product capabilities apply to properly and completely assembled products only.
7. Assemble on a flat, level, hard and smooth surface capable of safely supporting the Cabinet style Garment Rack.
8. For additional information regarding the parts listed in the following pages, please refer to the Assembly Diagram of this manual. Unwrap and separate all parts in a clean work area.

Use precautions

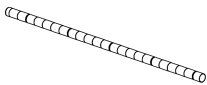
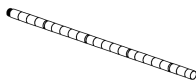
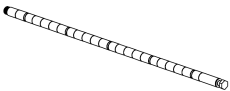
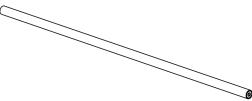
1. DO NOT SIT OR STAND ON THIS ITEM.
2. This product is not a toy. Do not allow children to play with or near this item.
3. Do not exceed specified weight capacities.
4. Use only on a flat, level, hard, and smooth surface that can safely support a fully loaded Cabinet style Garment Rack.
5. Use as intended only.
6. Inspect before every use; do not use if parts are loose or damaged.

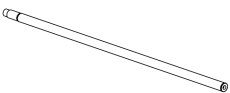
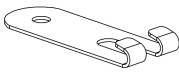
SAVE THIS MANUAL

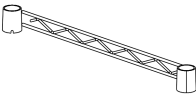
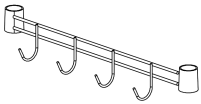
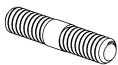
PARTS LIST

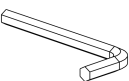
| | | |
|--|--|--|
| <p>A x2</p>  | <p>B x4</p>  | <p>C x8</p>  |
| <p>D x8</p>  | <p>E x8</p>  | <p>F x2</p>  |
| <p>G x1</p>  | <p>H x1</p>  | <p>I x6</p>  |
| <p>J x64+2</p>  | <p>K x2</p>  | <p>L x2</p>  |
| <p>M x2+1</p>  | <p>N x4+1</p>  | <p>x1</p>  |

ASSEMBLY STEP

step 1

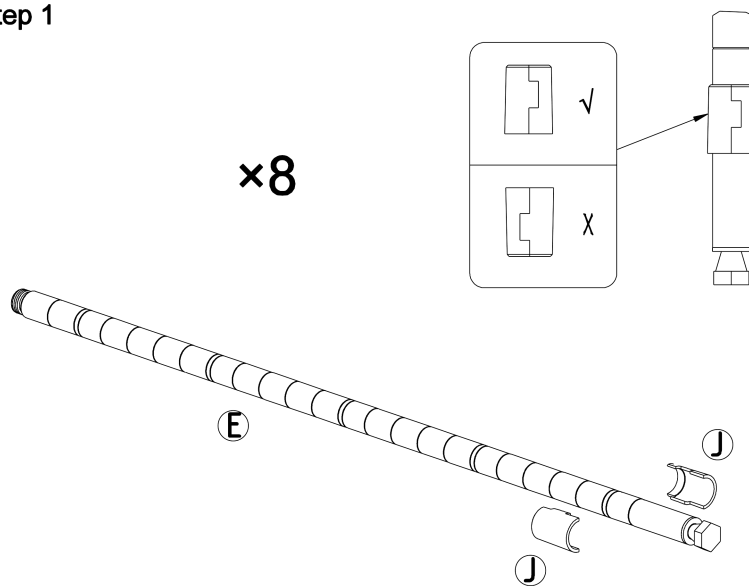

step 2

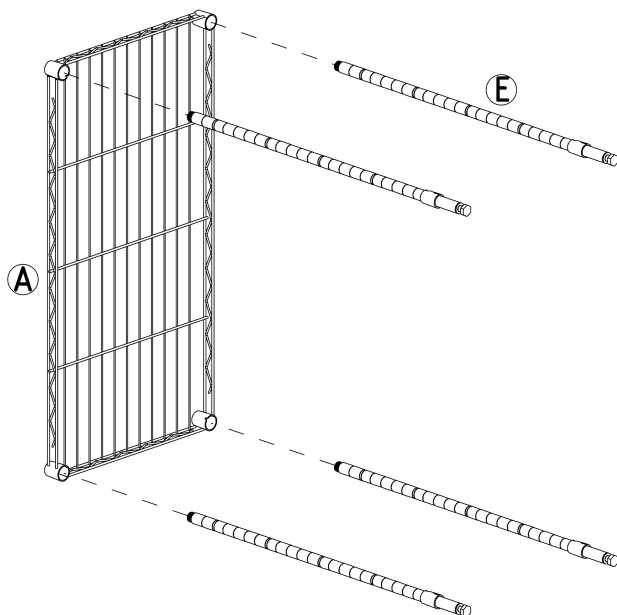

step 3

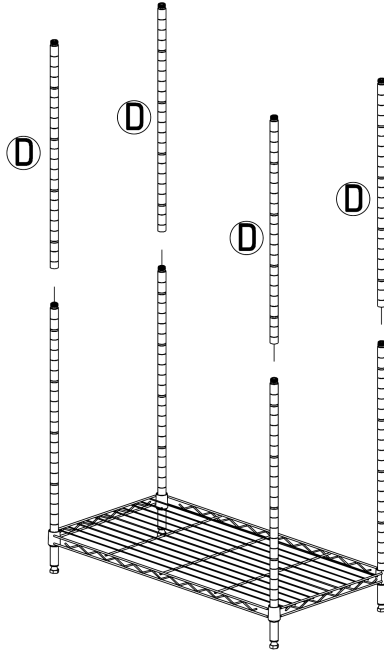

step 4

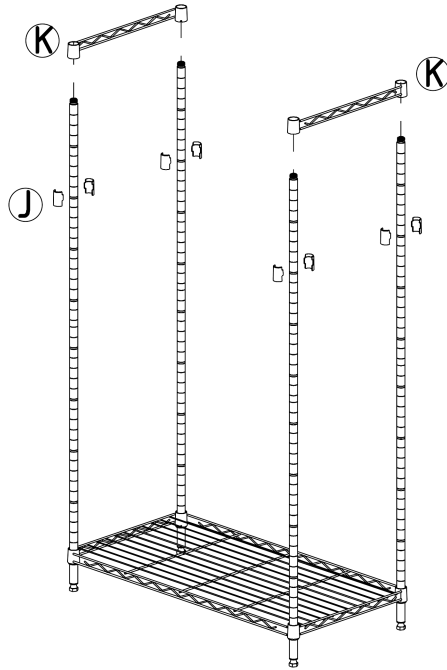

step 5

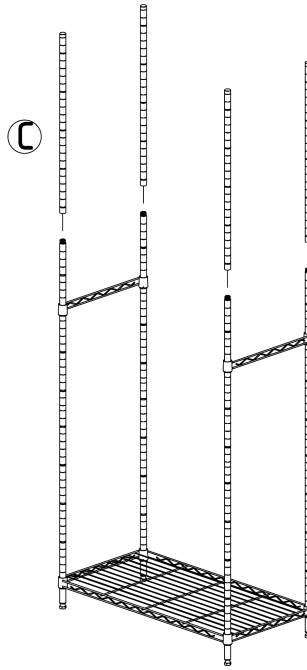

step 6

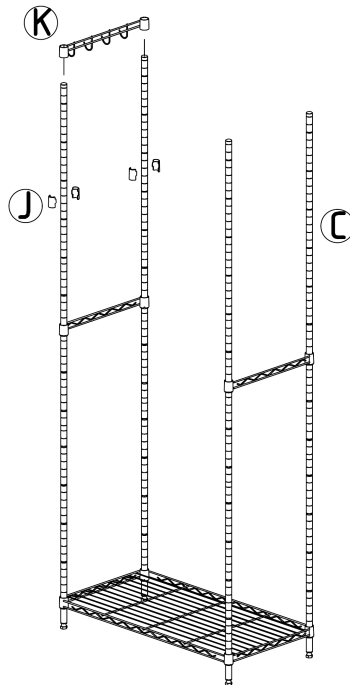

step 7

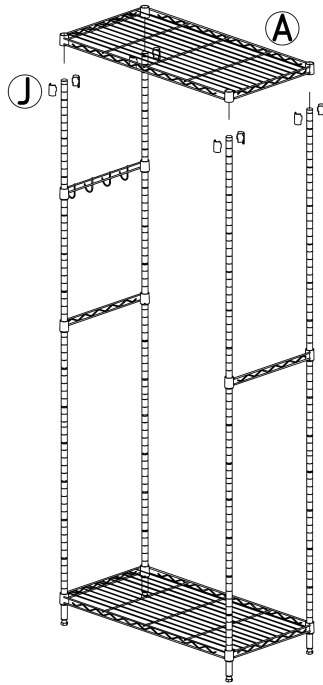

step 8

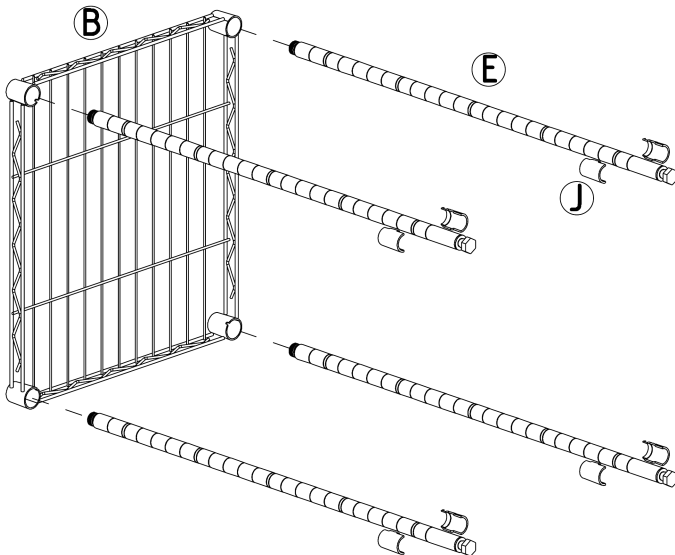

step 9

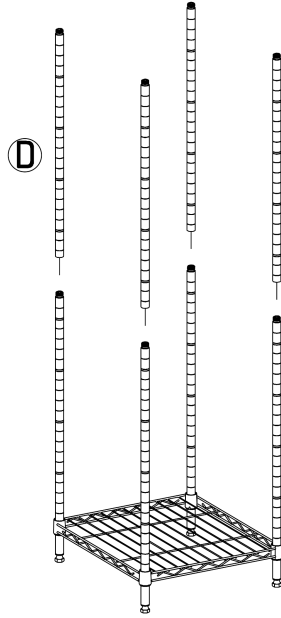

step 10

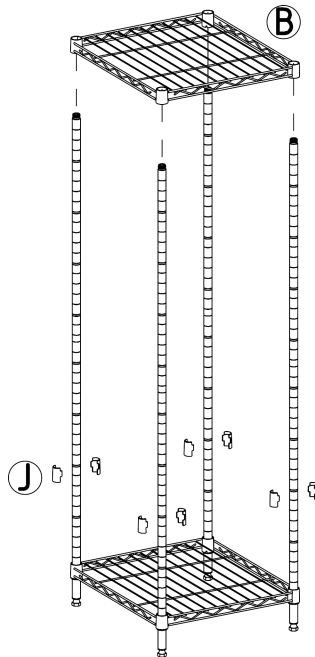

step 11

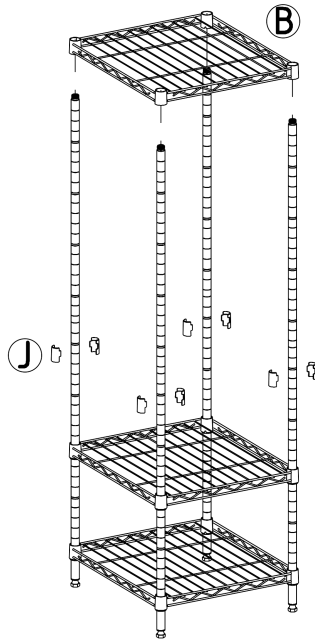

step 12

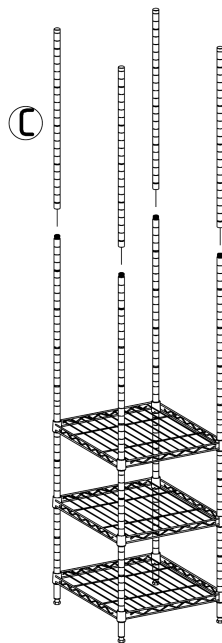

step 13

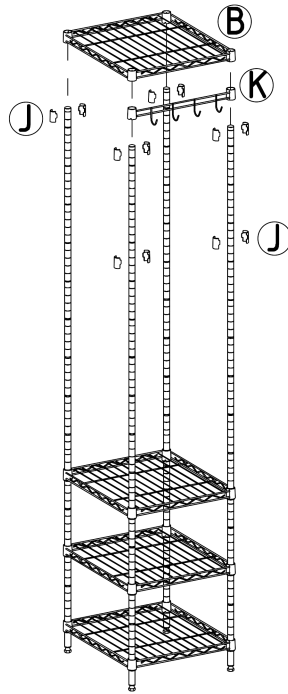

step 14

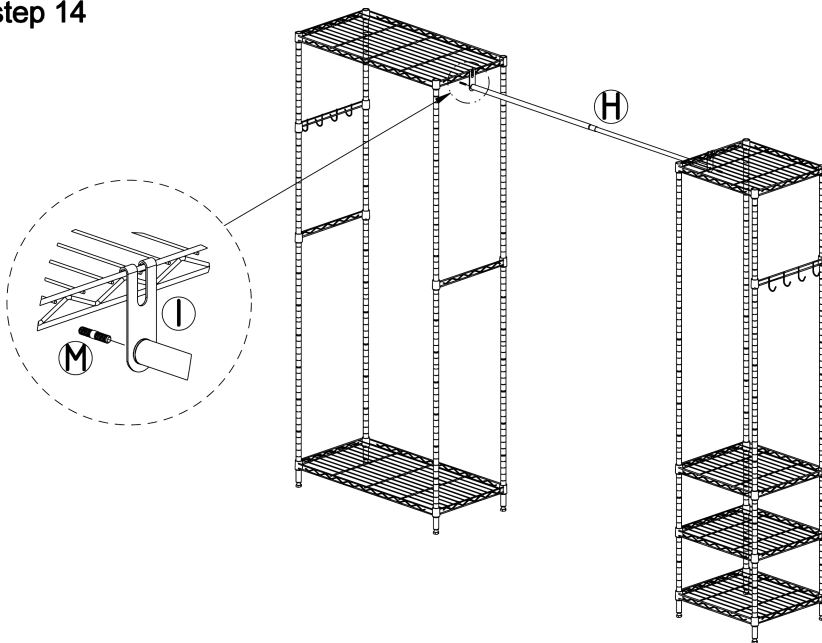

step 15

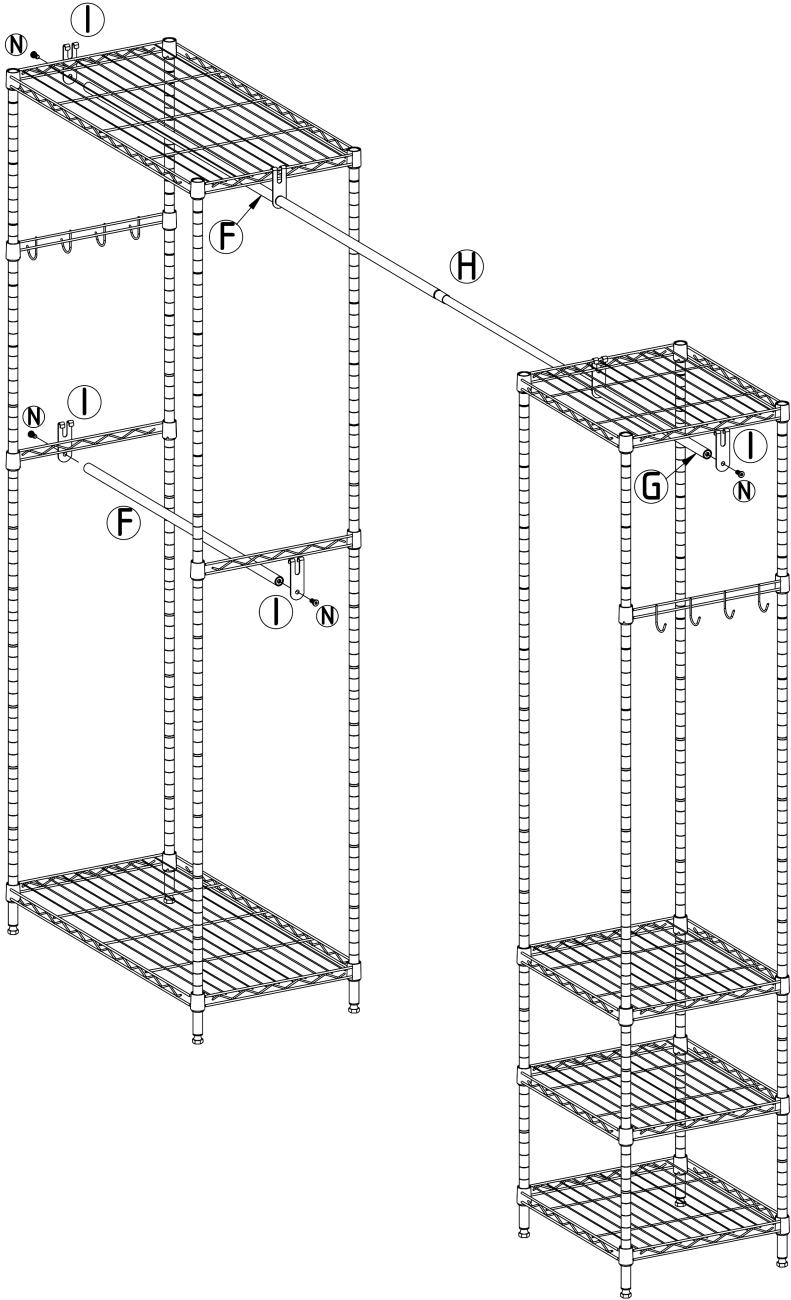

PRODUCT PARAMETER

| | |
|-------------------------------|---|
| Model | YC0009 |
| Colour | Black |
| Maximum Loading Weight | Weight: Up to 800 pounds (363 kg); Lattice Net: 40 kg Per Piece (Uniform Distribution); Fixed Hanging Rods: 30 kg Per Bar (Uniform Distribution); Extension Hanging Rods: 10 kg Per Bar (Uniform Distribution); Row Hooks: 12 kg Per Row (Uniform Distribution) |
| Product Size | 2440×380×1803.5mm |

Manufacturer: Shanghaimuxinmuyeyouxiangongsi

Address: Shuangchenglu 803nong11hao1602A-1609shi, baoshanqu, shanghai 200000 CN.

Imported to AUS: SIHAO PTY LTD. 1 ROKEVA STREETEASTWOOD NSW 2122 Australia

Imported to USA: Sanven Technology Ltd. Suite 250, 9166 Anaheim Place, Rancho Cucamonga, CA 91730

| | |
|-----------|------------|
| UK | REP |
|-----------|------------|

YH CONSULTING LIMITED. C/O YH Consulting Limited Office 147, Centurion House, London Road, Staines-upon-Thames, Surrey, TW18 4AX

| | |
|-----------|------------|
| EC | REP |
|-----------|------------|

E-CrossStu GmbH
Mainzer Landstr.69,
60329 Frankfurt am Main.



VEVOR

Affordable. Reliable. Home Improvement.

PORTE-VÊTEMENTS DE STYLE ARMOIRE

YC0009

VEVOR

Affordable. Reliable. Home Improvement.

STYLE D'ARMOIRE
PORTE-VÊTEMENTS

MODÈLE : YC0009

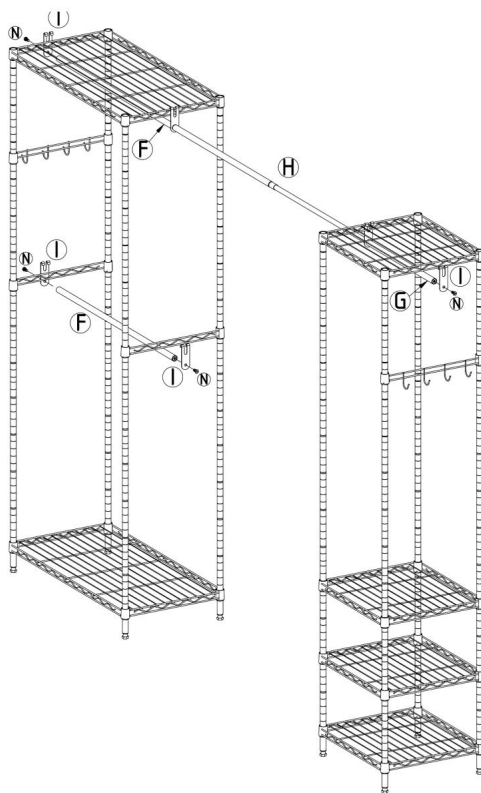

Ceci est le mode d'emploi d'origine. Veuillez lire attentivement l'intégralité du manuel avant utilisation. VEVOR se réserve le droit d'interpréter clairement ce manuel d'utilisation. L'apparence du produit dépend du produit que vous avez reçu. Veuillez nous excuser pour les éventuelles mises à jour technologiques ou logicielles.

CONSIGNES DE SÉCURITÉ

AVERTISSEMENT:

Veillez lire ce document avant d'utiliser ce produit. Le non-respect de cette consigne peut entraîner entraîner des blessures graves.

Précautions de montage









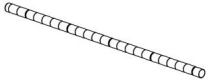

1. Assemblez uniquement conformément à ces instructions. Tout assemblage incorrect peut créer des dangers.
2. Portez des lunettes de sécurité approuvées par l'ANSI et des gants de travail robustes pendant le montage.
3. Gardez la zone de montage propre et bien éclairée.
4. Gardez les spectateurs hors de la zone pendant le montage.
5. Ne vous rassemblez pas si vous êtes fatigué ou sous l'influence de l'alcool, de drogues ou des médicaments.
6. Les capacités du produit s'appliquent à un produit correctement et complètement assemblé. produits uniquement.
7. Assemblez sur une surface plane, de niveau, dure et lisse, capable de supporter en toute sécurité supportant le porte-vêtements de style armoire.
8. Pour plus d'informations sur les pièces répertoriées ci-dessous pages, veuillez vous référer au schéma d'assemblage de ce manuel. Déballer et séparer toutes les pièces dans une zone de travail propre.

Précautions d'emploi

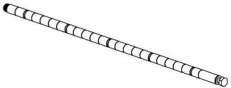
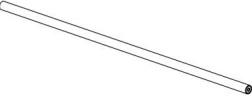
1. NE PAS S'ASSEOIR NI SE TENIR DEBOUT SUR CET ARTICLE.
2. Ce produit n'est pas un jouet. Ne laissez pas les enfants jouer avec ou à proximité. article.
3. Ne pas dépasser les capacités de poids spécifiées.
4. Utiliser uniquement sur une surface plane, de niveau, dure et lisse qui peut être utilisée en toute sécurité soutenir un porte-vêtements de style armoire entièrement chargé.
5. Utiliser uniquement comme prévu.
6. Inspectez avant chaque utilisation ; ne pas utiliser si des pièces sont desserrées ou endommagées.

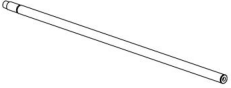
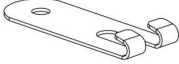
CONSERVEZ CE MANUEL

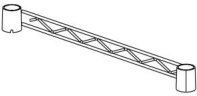
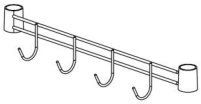
LISTE DES PIÈCES

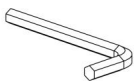
| | | |
|--|--|--|
| <p>A x2</p>  | <p>B x4</p>  | <p>C x8</p>  |
| <p>D x8</p>  | <p>E x8</p>  | <p>F x2</p>  |
| <p>G x1</p>  | <p>H x1</p>  | <p>I x6</p>  |
| <p>J x64+2</p>  | <p>K x2</p>  | <p>L x2</p>  |
| <p>M x2+1</p>  | <p>N x4+1</p>  | <p>x1</p>  |

step 1

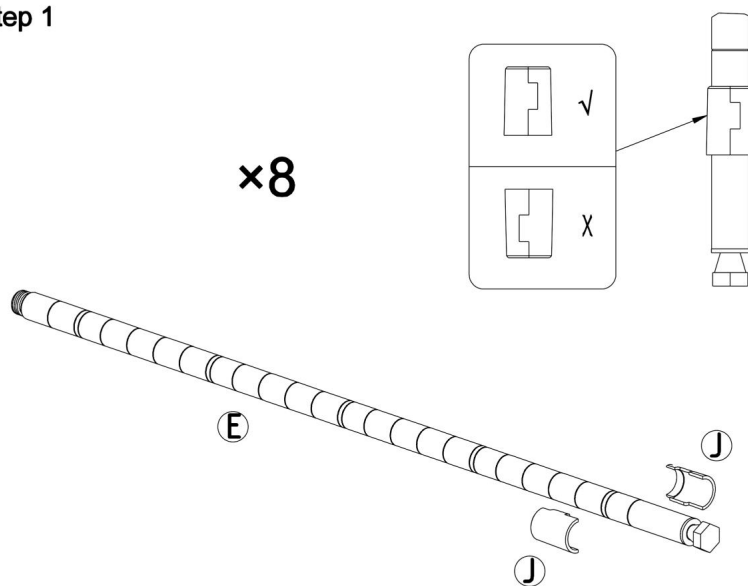

step 2

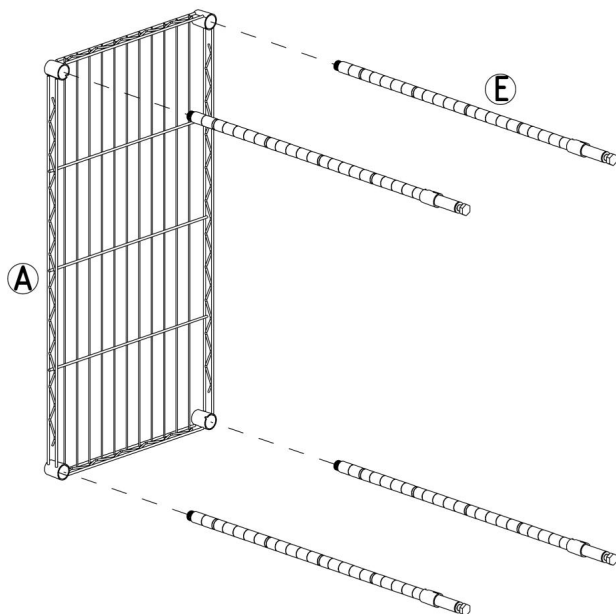

step 3

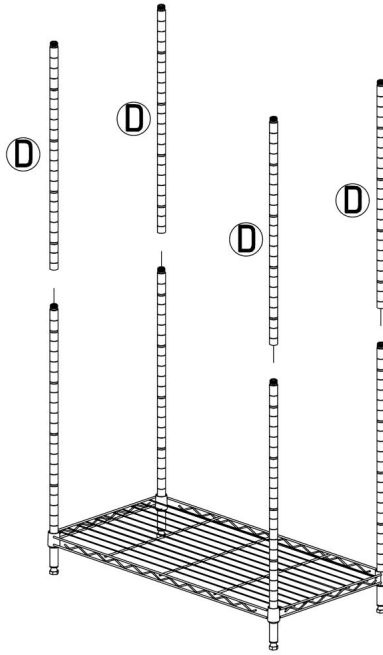

step 4

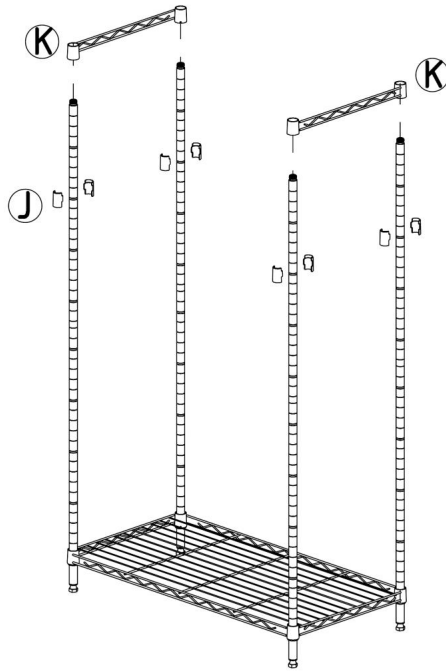

step 5

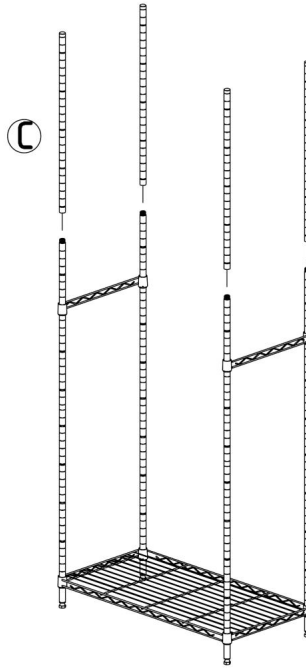

step 6

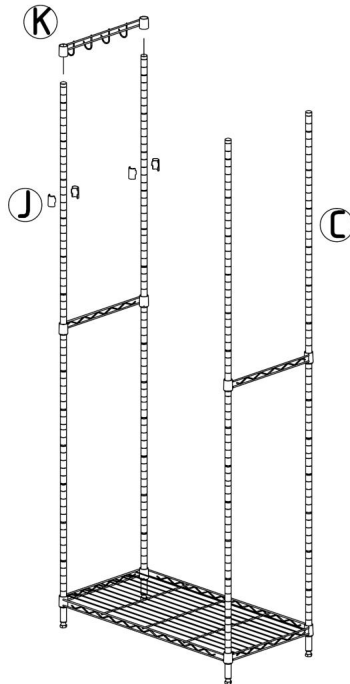

step 7

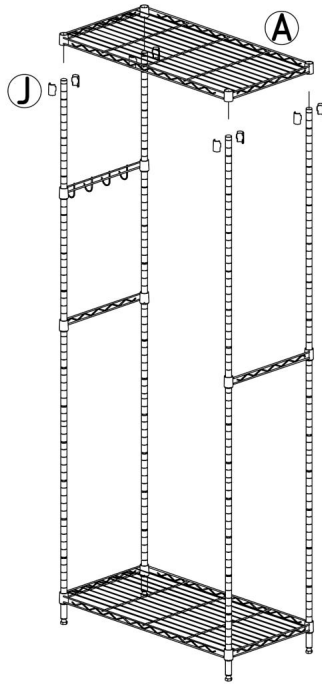

step 8

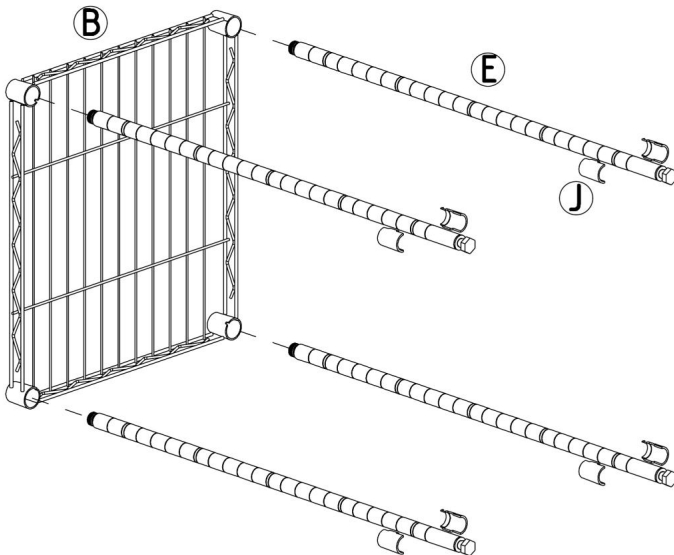

step 9

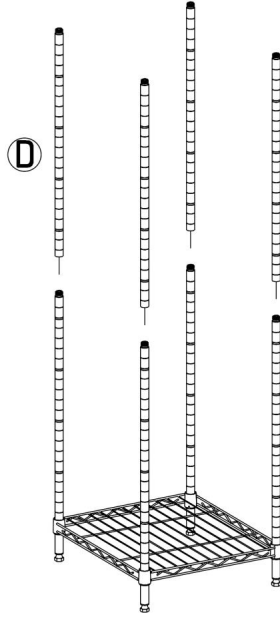

step 10

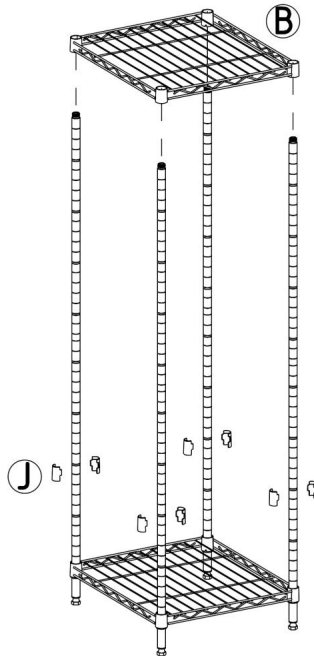

step 11

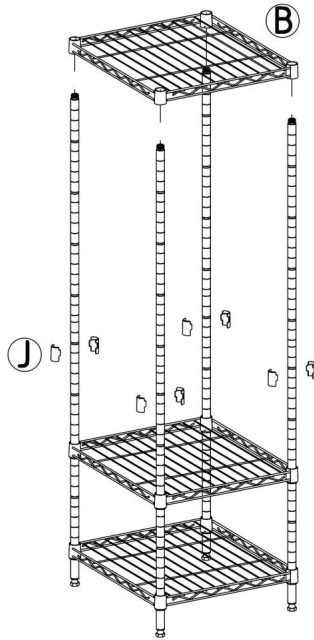

step 12

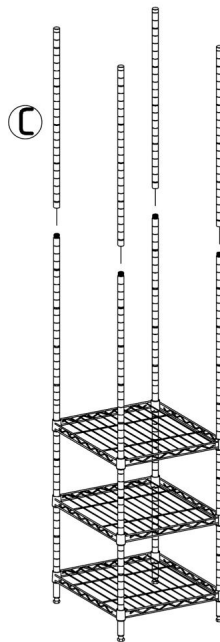

step 13

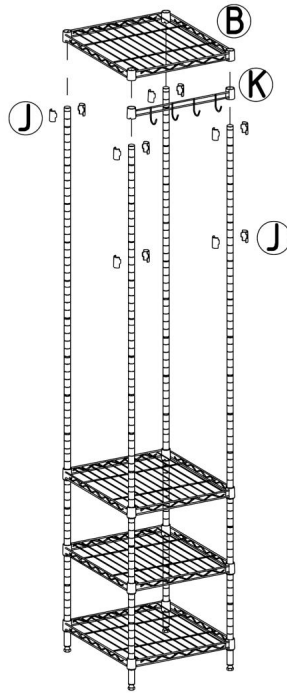

step 14

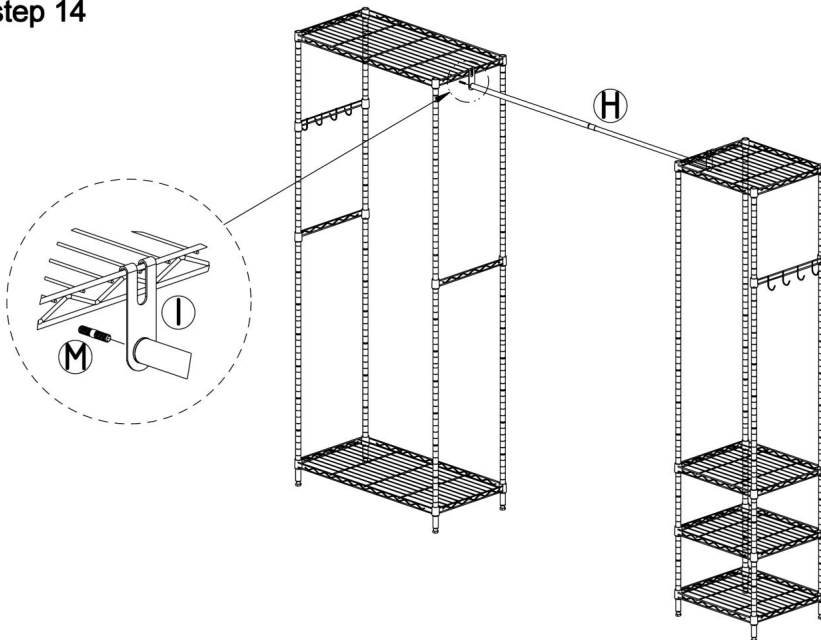

step 15

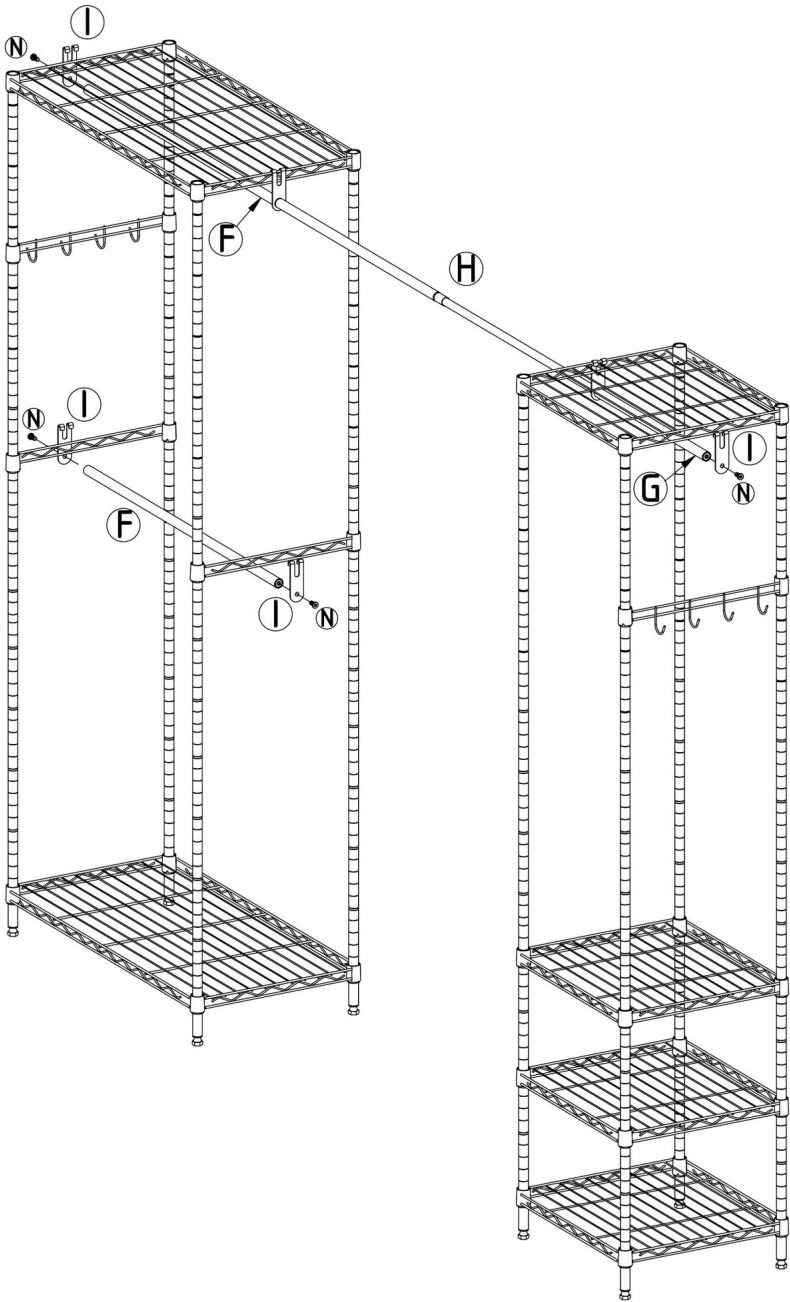

PARAMÈTRE DU PRODUIT

| | |
|--------------------------------|--|
| Modèle | YC0009 |
| Couleur | Noir |
| Maximum Poids de chargement | Poids : jusqu'à 800 livres (363 kg) ; Filet en treillis : 40 kg par pièce (répartition uniforme) ; Barres de suspension fixes : 30 kg par barre (répartition uniforme) ; Tiges de suspension extensibles : 10 kg par barre (uniforme) Distribution); Crochets de rang : 12 kg par rang (répartition uniforme) |
| Taille du produit | 2440 × 380 × 180 3,5 mm |

Fabricant : Shanghaimuxinmuyeyouxiangongsi Adresse :
Shuangchenglu 803nong11hao1602A-1609shi, baoshanqu, shanghai 200000 CN.

Importé en Australie : SIHAO PTY LTD. 1 ROKEVA STREET, ASTWOOD NSW 2122,
Australie

Importé aux États-Unis : Sanven Technology Ltd. Suite 250, 9166 Anaheim Place,
Rancho Cucamonga, CA 91730



YH CONSULTING LIMITED. A/S YH Consulting
Limited, bureau 147, Centurion House, London
Road, Staines-upon-Thames, Surrey, TW18 4AX



E-CrossStu GmbH
Mainzer Landstr.69,
60329 Francfort-sur-le-Main.



VEVOR

Affordable. Reliable. Home Improvement.

Kleiderständer im Schrankstil

YC0009

MODELL: YC0009

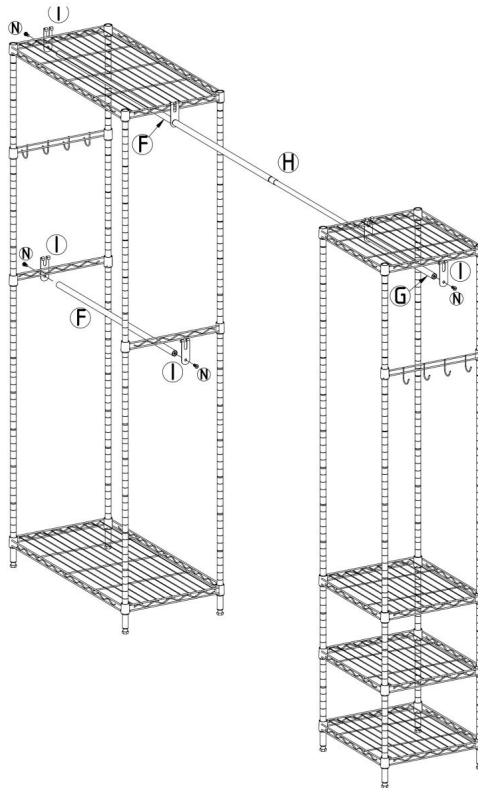

Dies ist die Originalanleitung. Bitte lesen Sie alle Anweisungen sorgfältig durch, bevor Sie das Gerät in Betrieb nehmen. VEVOR behält sich das Recht vor, die Bedienungsanleitung klar und deutlich zu interpretieren. Das Aussehen des Produkts hängt vom gelieferten Produkt ab. Bitte haben Sie Verständnis dafür, dass wir Sie nicht erneut über Technologie- oder Software-Updates informieren.

SICHERHEITSHINWEISE

WARNUNG:

Lesen Sie dieses Material, bevor Sie dieses Produkt verwenden. Die Nichtbeachtung kann zu schweren Verletzungen führen.

Vorsichtsmaßnahmen bei der Montage









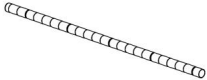

1. Die Montage muss gemäß dieser Anleitung erfolgen. Unsachgemäße Montage kann Gefahren verursachen.
2. Tragen Sie eine ANSI-zugelassene Schutzbrille und robuste Arbeitshandschuhe während der Montage.
3. Halten Sie den Versammlungsbereich sauber und gut beleuchtet.
4. Halten Sie während der Montage unbeteiligte Personen vom Bereich fern.
5. Montieren Sie nicht, wenn Sie müde sind oder unter dem Einfluss von Alkohol, Drogen oder Medikamenten.
6. Die Produkteigenschaften gelten für ordnungsgemäß und vollständig montierte nur Produkte.
7. Auf einer flachen, ebenen, harten und glatten Oberfläche montieren, die sicher Unterstützung des Kleiderständers im Schrankstil.
8. Weitere Informationen zu den im Folgenden aufgeführten Teilen finden Sie Seiten finden Sie im Montagediagramm dieses Handbuchs. Auspacken und trennen Sie alle Teile in einem sauberen Arbeitsbereich.

Vorsichtsmaßnahmen treffen

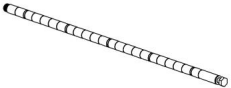
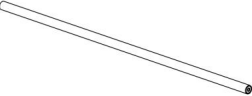
1. Setzen oder stellen Sie sich nicht auf diesen Gegenstand.
2. Dieses Produkt ist kein Spielzeug. Erlauben Sie Kindern nicht, mit diesem Produkt zu spielen oder in dessen Nähe zu Artikel.
3. Überschreiten Sie nicht die angegebene Gewichtskapazität.
4. Nur auf einer flachen, ebenen, harten und glatten Oberfläche verwenden, die sicher unterstützt einen voll beladenen Kleiderständer im Schrankstil.
5. Nur bestimmungsgemäß verwenden.
6. Vor jedem Gebrauch prüfen; nicht verwenden, wenn Teile lose oder beschädigt sind.

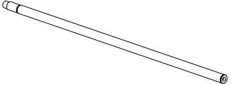
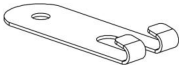
BEWAHREN SIE DIESES HANDBUCH AUF

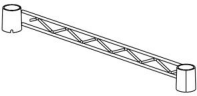
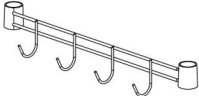
TEILELISTE

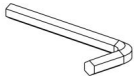
| | | |
|--|--|--|
| <p>A x2</p>  | <p>B x4</p>  | <p>C x8</p>  |
| <p>D x8</p>  | <p>E x8</p>  | <p>F x2</p>  |
| <p>G x1</p>  | <p>H x1</p>  | <p>I x6</p>  |
| <p>J x64+2</p>  | <p>K x2</p>  | <p>L x2</p>  |
| <p>M x2+1</p>  | <p>N x4+1</p>  | <p>x1</p>  |

MONTAGESTRITT

step 1

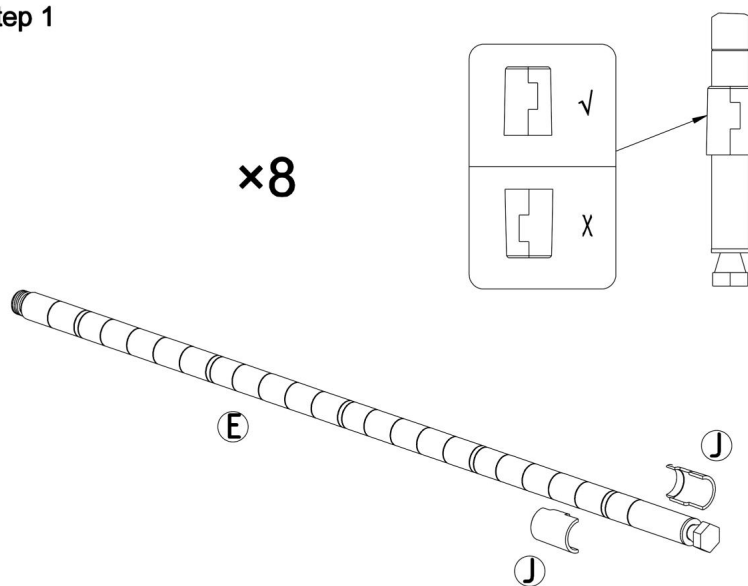

step 2

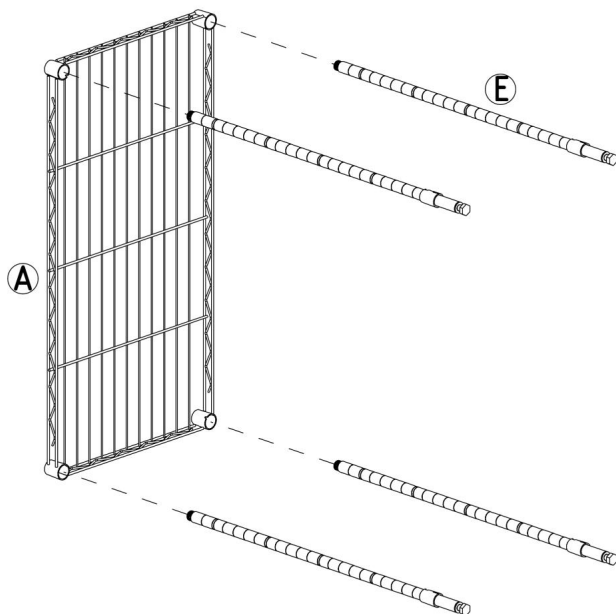

step 3

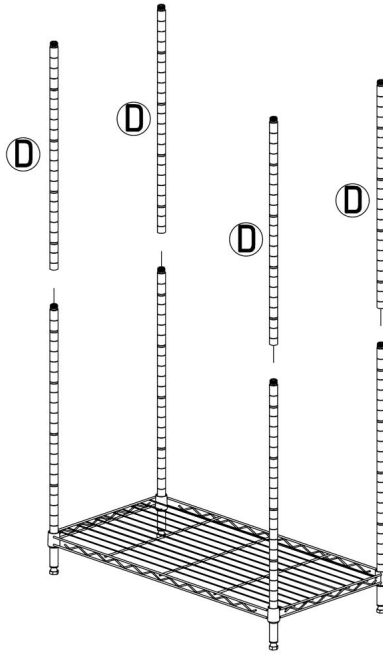

step 4

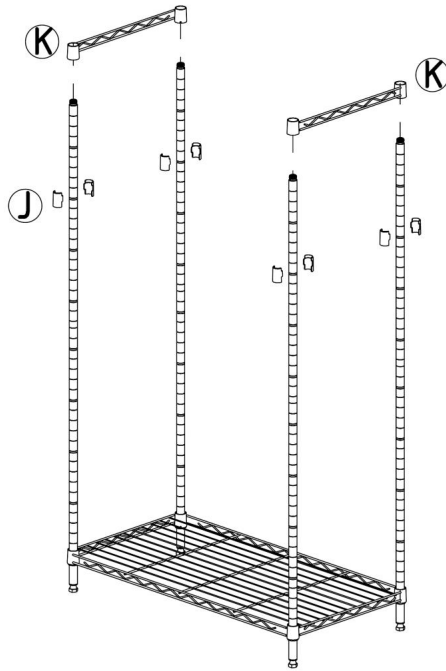

step 5

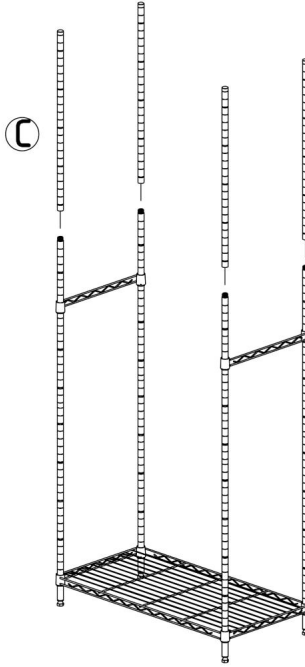

step 6

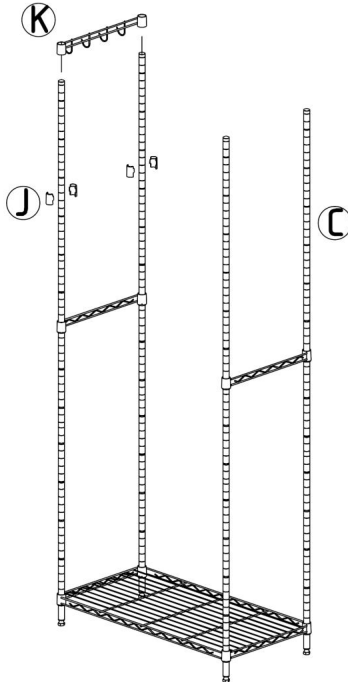

step 7

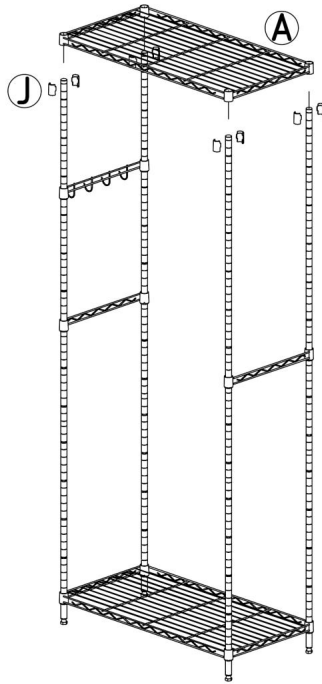

step 8

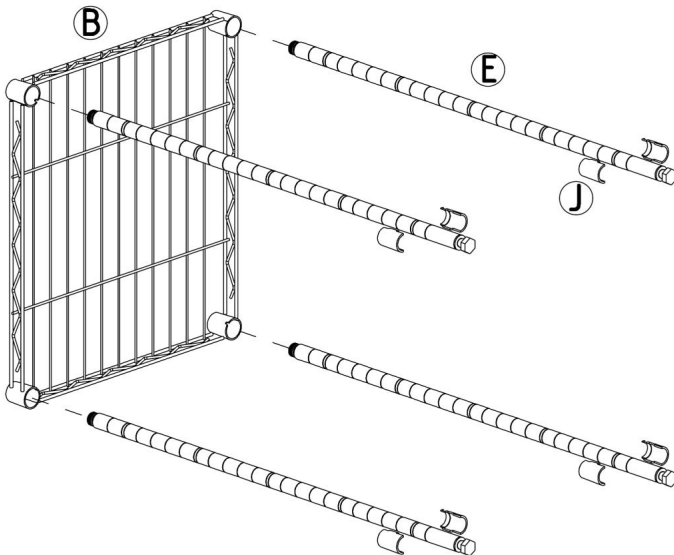

step 9

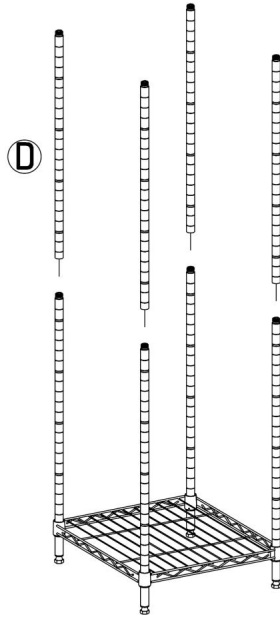

step 10

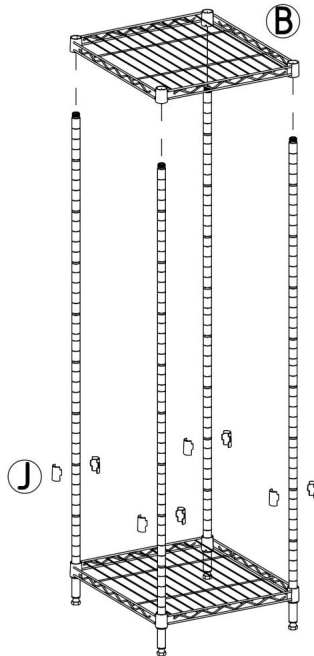

step 11

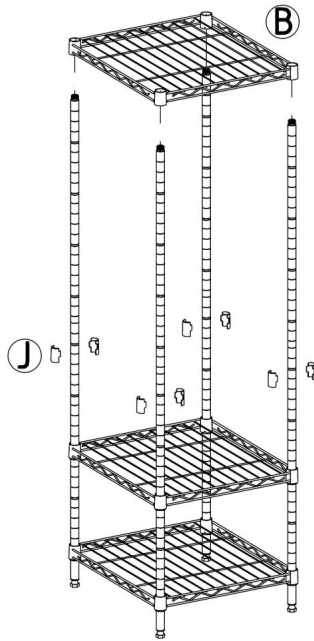

step 12

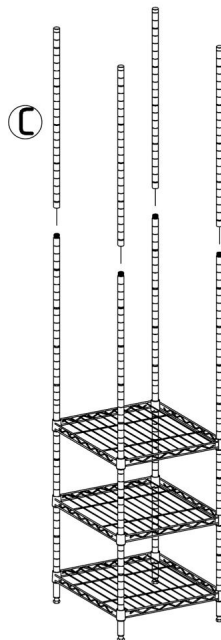

step 13

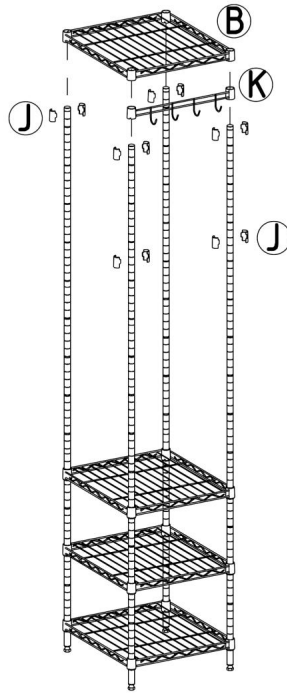

step 14

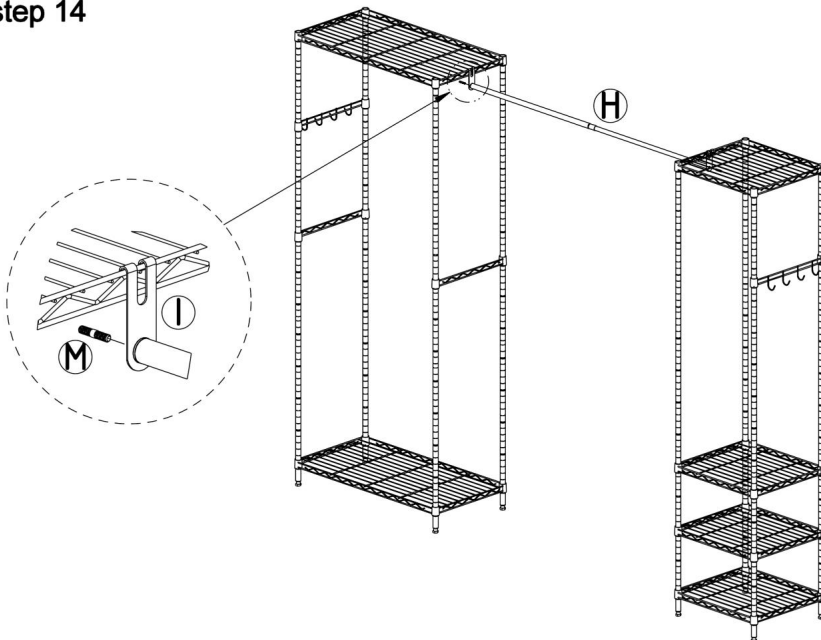

step 15

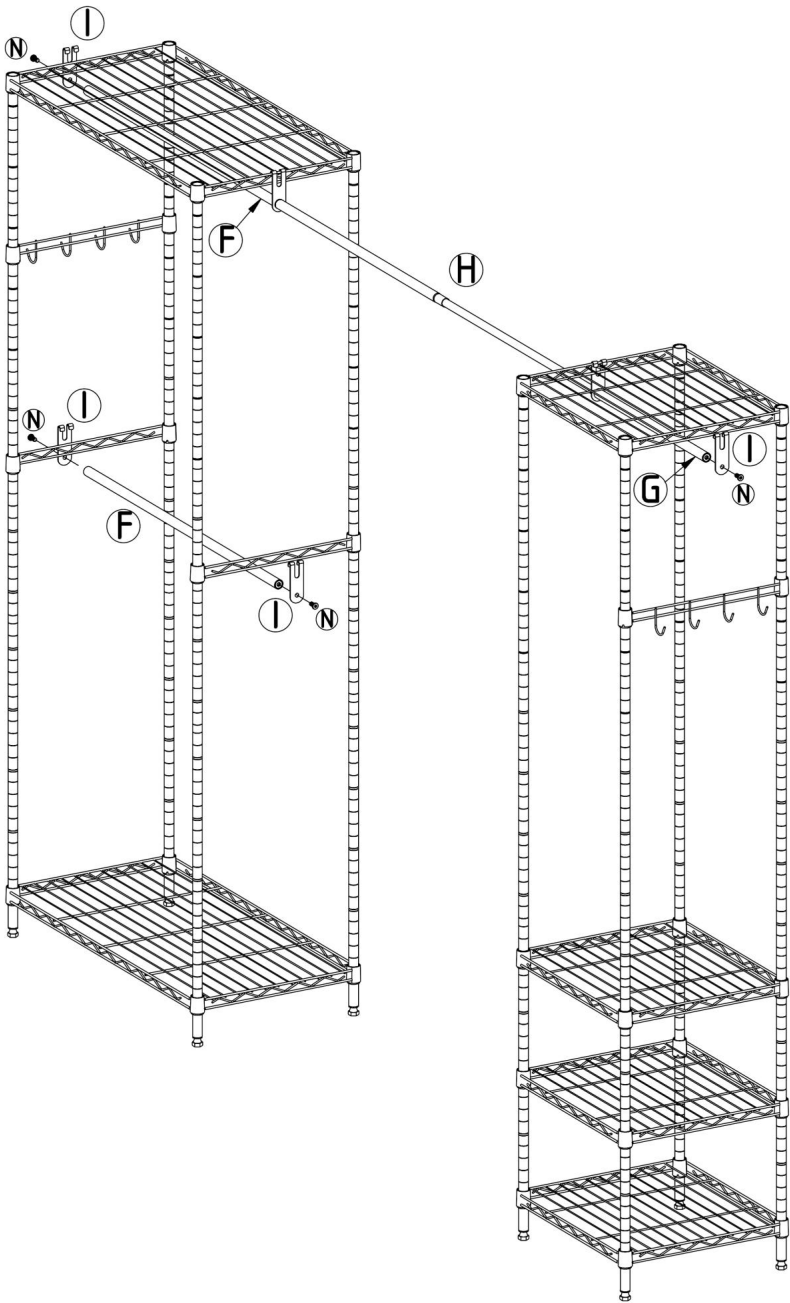

PRODUKTPARAMETER

| | |
|--------------------------------|--|
| Modell | YC0009 |
| Farbe | Schwarz |
| Maximal Ladegewicht | Gewicht: Bis zu 800 Pfund (363 kg); Gitternetz: 40 kg pro Stück (gleichmäßige Verteilung); Feste Aufhängestangen: 30 kg pro Stange (gleichmäßige Verteilung); Verlängerungsstangen: 10 kg pro Stange (einheitlich Verteilung); Reihenhaken: 12 kg pro Reihe (gleichmäßige Verteilung) |
| Produktgröße | 2440×380×1803,5 mm |

Hersteller: Shanghaimuxinmuyeyouxiangongsi **Adresse:**

Shuangchenglu 803nong11hao1602A-1609shi, baoshanqu, Shanghai 200000 CN.

Importiert nach AUS: SIHAO PTY LTD. 1 ROKEVA STREETEASTWOOD NSW 2122
Australien

Importiert in die USA: Sanven Technology Ltd. Suite 250, 9166 Anaheim Place,
Rancho Cucamonga, CA 91730

| | |
|---------------------------|--|
| Britische Republik | |
|---------------------------|--|

YH CONSULTING LIMITED. C/O YH Consulting
Limited, Büro 147, Centurion House, London
Road, Staines-upon-Thames, Surrey, TW18 4AX

| | |
|---------------------|--|
| EG-Vertreter | |
|---------------------|--|

E-CrossStu GmbH
Mainzer Landstr.69,
60329 Frankfurt am Main.



VEVOR

Affordable. Reliable. Home Improvement.

APPENDIABITI IN STILE ARMADIO

YC0009

VEVOR

Affordable. Reliable. Home Improvement.

STILE DEL MOBILE
APPENDIABILI

MODELLO: YC0009

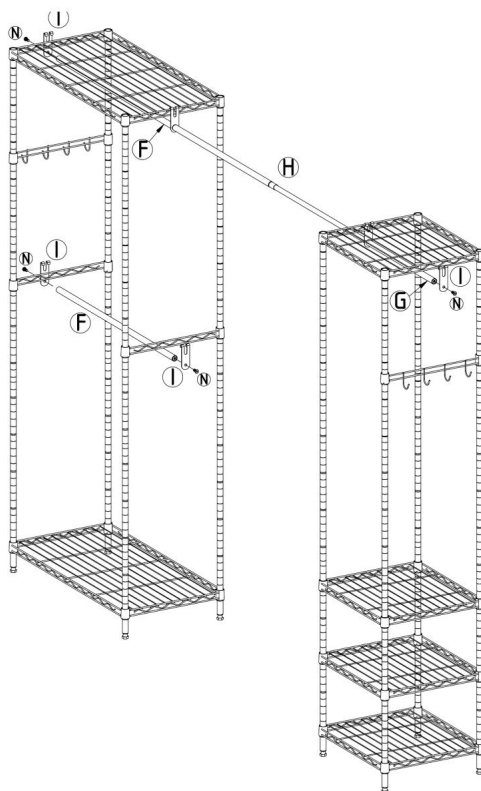

Queste sono le istruzioni originali, si prega di leggere attentamente tutte le istruzioni del manuale prima di utilizzare il prodotto. VEVOR si riserva la piena interpretazione del manuale utente. L'aspetto del prodotto dipenderà dal prodotto ricevuto. Vi preghiamo di non informarvi ulteriormente in caso di aggiornamenti tecnologici o software relativi al nostro prodotto.

ISTRUZIONI DI SICUREZZA

AVVERTIMENTO:

Leggere attentamente questo materiale prima di utilizzare il prodotto. In caso contrario, si potrebbe provocare lesioni gravi.

Precauzioni di montaggio









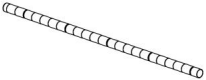

1. Montare solo secondo queste istruzioni. Montaggio non corretto può creare pericoli.
2. Indossare occhiali di sicurezza approvati ANSI e guanti da lavoro resistenti durante l'assemblaggio.
3. Mantenere l'area di assemblaggio pulita e ben illuminata.
4. Tenere gli astanti fuori dall'area durante l'assemblea.
5. Non riunirsi se stanchi o sotto l'effetto di alcol o droghe o farmaci.
6. Le capacità del prodotto si applicano a prodotti correttamente e completamente assemblati solo prodotti.
7. Montare su una superficie piana, livellata, dura e liscia in grado di sopportare in modo sicuro a supporto dell'appendiabiti in stile mobiletto.
8. Per ulteriori informazioni sulle parti elencate di seguito pagine, fare riferimento allo schema di montaggio di questo manuale. Disimballare e separare tutte le parti in un'area di lavoro pulita.

Usare precauzioni

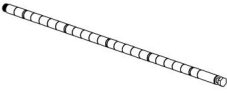
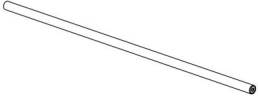
1. NON SEDERSI O STARE IN PIEDI SU QUESTO OGGETTO.
2. Questo prodotto non è un giocattolo. Non permettere ai bambini di giocare con o vicino a questo prodotto. articolo.
3. Non superare le capacità di peso specificate.
4. Utilizzare solo su una superficie piana, livellata, dura e liscia che possa essere utilizzata in sicurezza Supporta un appendiabiti in stile armadio completamente accessoriatto.
5. Utilizzare solo come previsto.
6. Ispezionare prima di ogni utilizzo; non utilizzare se alcune parti risultano allentate o danneggiate.

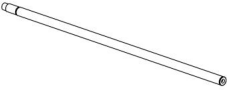
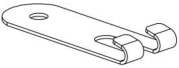
CONSERVARE QUESTO MANUALE

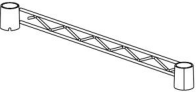
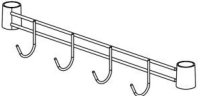
ELENCO DEI PEZZI

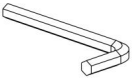
| | | |
|--|--|--|
| <p>A x2</p>  | <p>B x4</p>  | <p>C x8</p>  |
| <p>D x8</p>  | <p>E x8</p>  | <p>F x2</p>  |
| <p>G x1</p>  | <p>H x1</p>  | <p>I x6</p>  |
| <p>J x64+2</p>  | <p>K x2</p>  | <p>L x2</p>  |
| <p>M x2+1</p>  | <p>N x4+1</p>  | <p>x1</p>  |

FASE DI MONTAGGIO

step 1

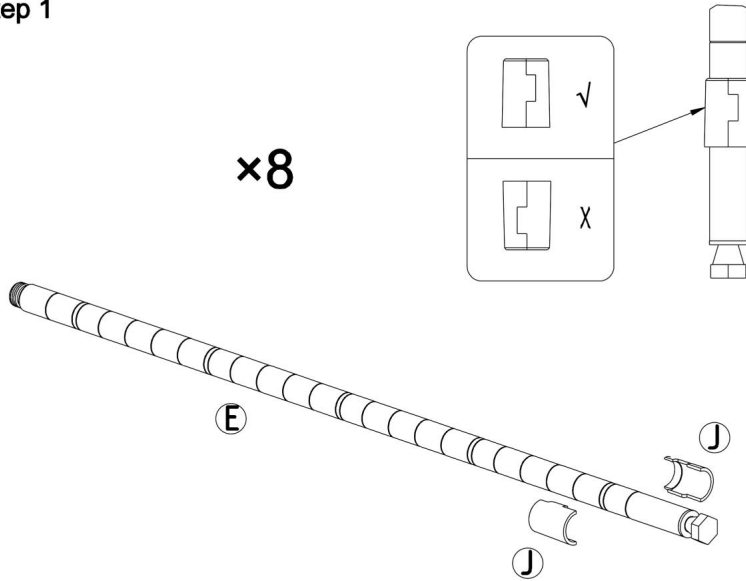

step 2

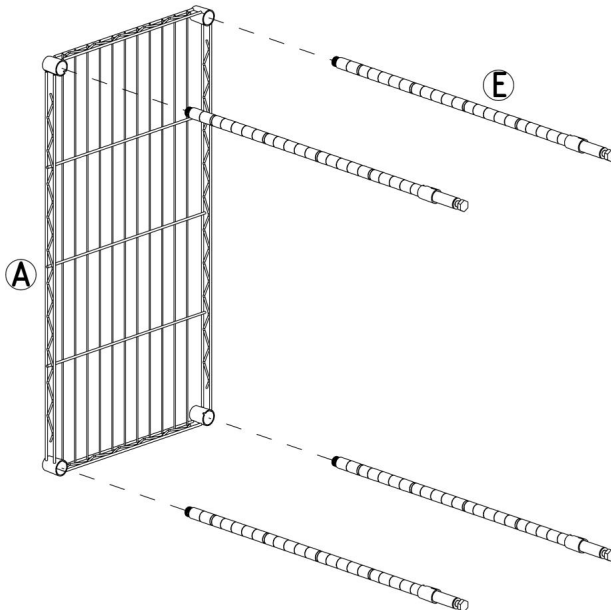

step 3

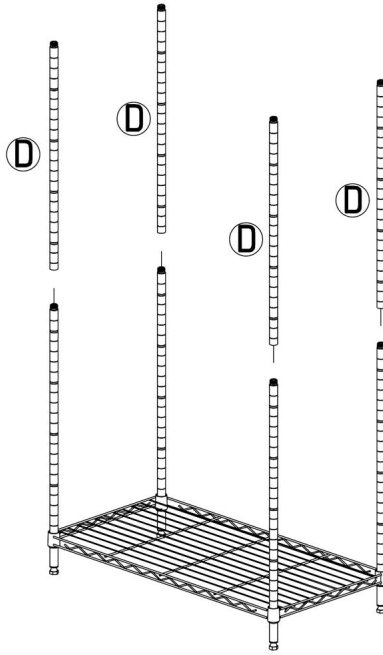

step 4

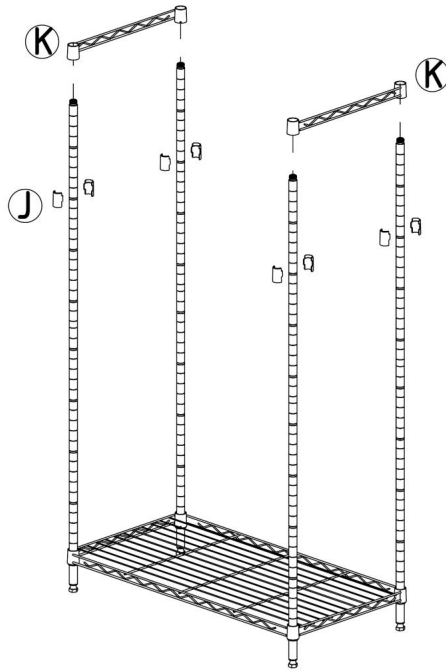

step 5

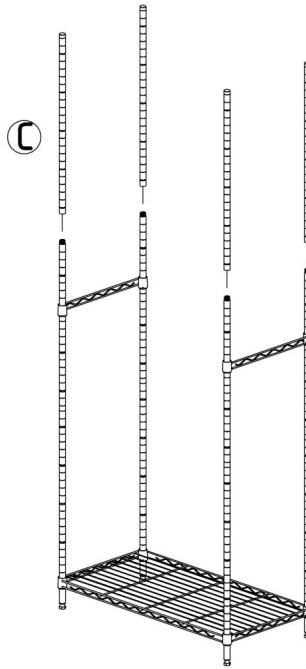

step 6

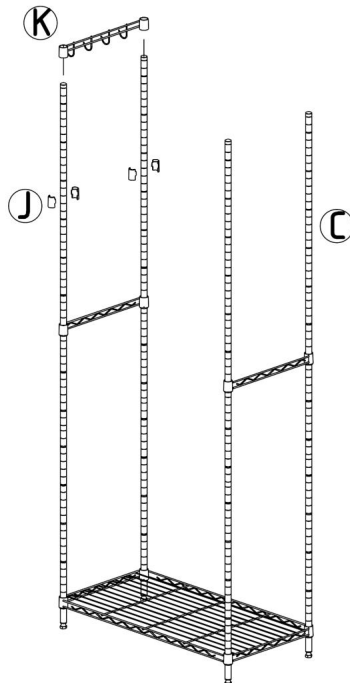

step 7

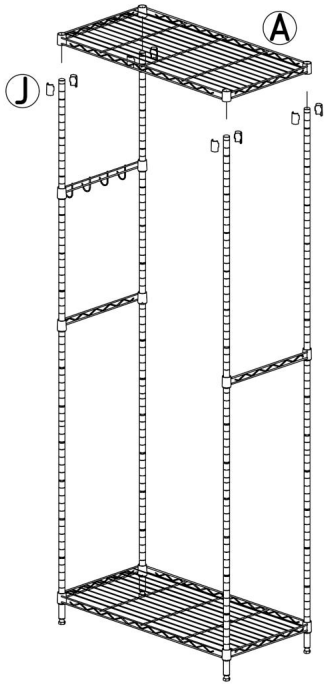

step 8

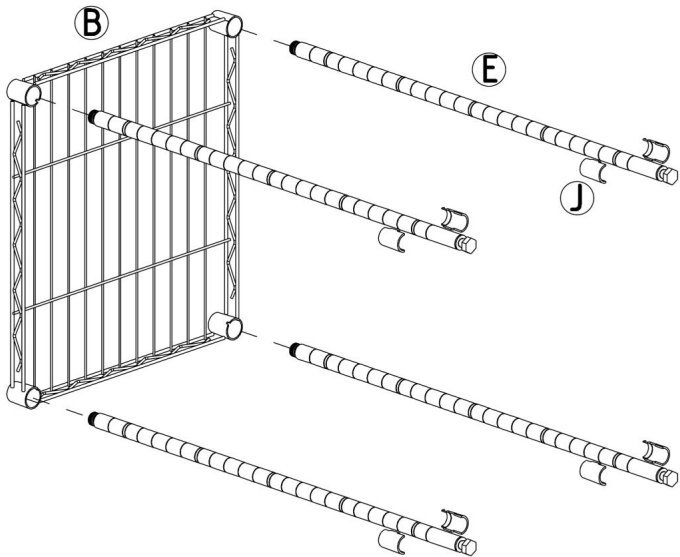

step 9

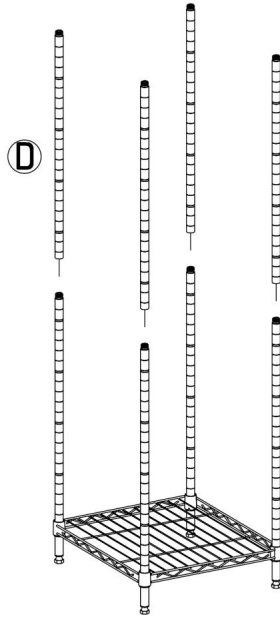

step 10

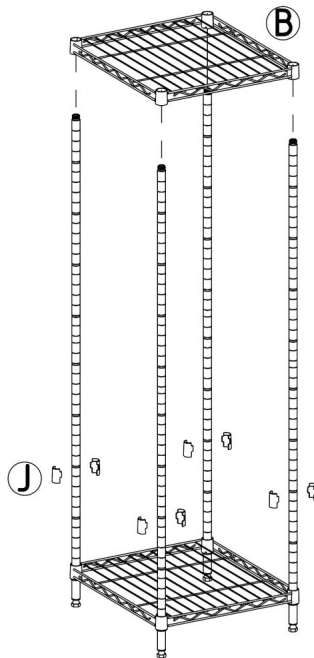

step 11

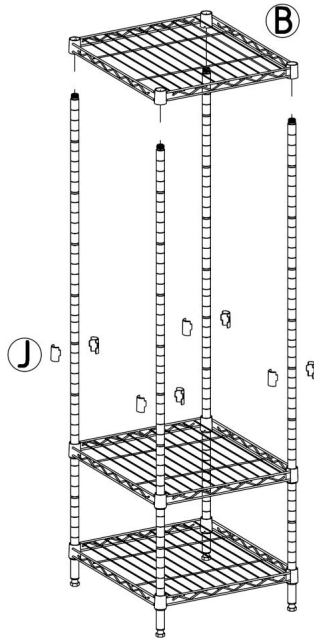

step 12

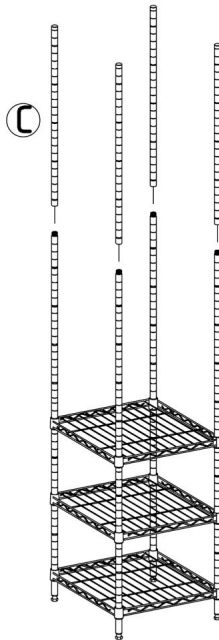

step 13

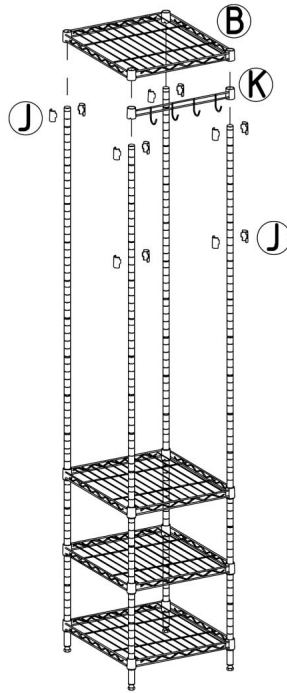

step 14

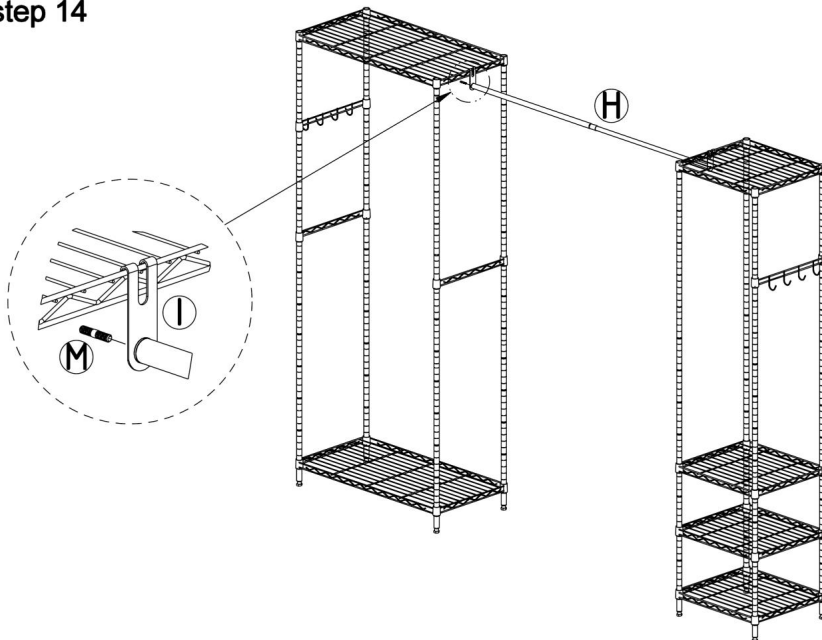

step 15

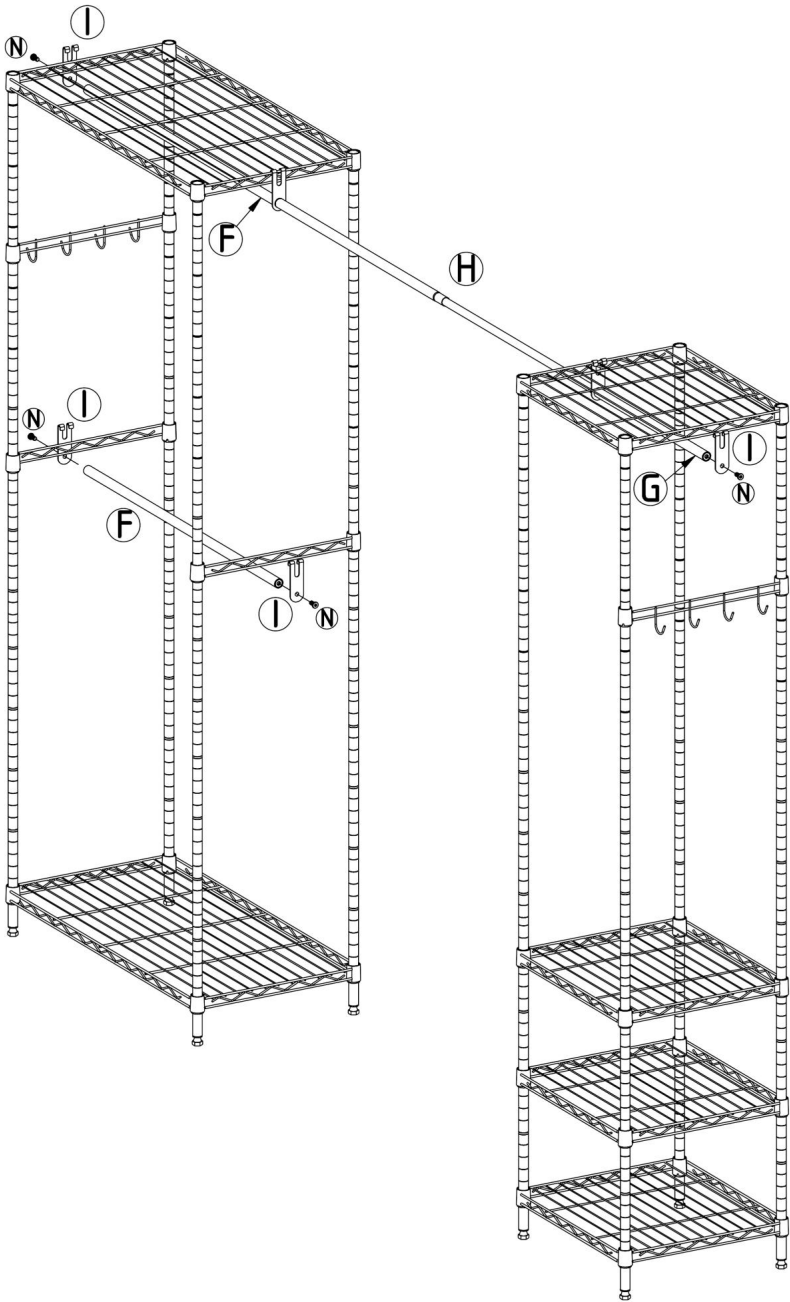

PARAMETRO DEL PRODOTTO

| | |
|-----------------------------------|---|
| Modello | YC0009 |
| Colore | Nero |
| Massimo Peso di carico | Peso: fino a 800 libbre (363 kg); Rete reticolare: 40 kg per pezzo (distribuzione uniforme); Aste di sospensione fisse: 30 kg per barra (distribuzione uniforme); Aste di sospensione estensibili: 10 kg per barra (uniforme Distribuzione); Ganci per fila: 12 kg per fila (distribuzione uniforme) |
| Dimensioni del prodotto | 2440x380x1803,5 mm |

Produttore: Shanghaimuxinmuyeyouxiangongsi **Indirizzo:**

Shuangchenglu 803nong11hao1602A-1609shi, baoshanqu, shanghai 200000 CN.

Importato in AUS: SIHAO PTY LTD. 1 ROKEVA STREETEASTWOOD NSW 2122
Australia

Importato negli USA: Sanven Technology Ltd. Suite 250, 9166 Anaheim Place,
Rancho Cucamonga, CA 91730



YH CONSULTING LIMITED. C/O YH Consulting
Limited Ufficio 147, Centurion House, London
Road, Staines-upon-Thames, Surrey, TW18 4AX

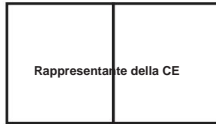

E-CrossStu GmbH
Mainzer Landstr.69,
60329 Francoforte sul Meno.



VEVOR

Affordable. Reliable. Home Improvement.

PERCHERO ESTILO GABINETE

YC0009

VEVOR

Affordable. Reliable. Home Improvement.

ESTILO DE GABINETE
PERCHERO

MODELO: YC0009

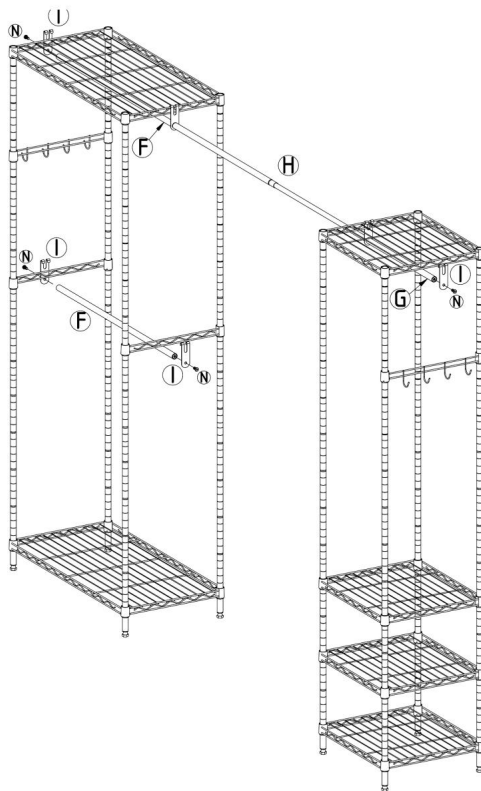

Estas son las instrucciones originales; lea atentamente todas las instrucciones del manual antes de utilizarlo. VEVOR se reserva el derecho de interpretar su manual de usuario. La apariencia del producto dependerá del producto que haya recibido. Le rogamos que no le informemos si hay actualizaciones tecnológicas o de software en nuestro producto.

INSTRUCCIONES DE SEGURIDAD

ADVERTENCIA:

Lea este material antes de usar este producto. De lo contrario, podría...
provocar lesiones graves.

Precauciones de montaje









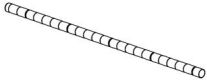

1. Ensamble únicamente según estas instrucciones. Montaje incorrecto.
Puede crear peligros.
2. Use gafas de seguridad aprobadas por ANSI y guantes de trabajo resistentes.
Durante el montaje.
3. Mantenga el área de montaje limpia y bien iluminada.
4. Mantenga a los transeúntes fuera del área durante el montaje.
5. No se reúna si está cansado o bajo la influencia del alcohol o drogas.
o medicación.
6. Las capacidades del producto se aplican a productos ensamblados correctamente y completamente.
Sólo productos.
7. Montar sobre una superficie plana, nivelada, dura y lisa capaz de soportar condiciones de seguridad.
Soporte para perchero estilo gabinete.
8. Para obtener información adicional sobre las piezas enumeradas a continuación,
páginas, consulte el diagrama de montaje de este manual. Desenvuelva
y separe todas las piezas en un área de trabajo limpia.

Precauciones de uso

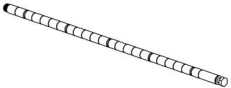
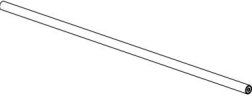
1. NO SE SIENTA NI SE PARE SOBRE ESTE ARTÍCULO.
2. Este producto no es un juguete. No permita que los niños jueguen con él ni cerca de él.
artículo.
3. No exceda las capacidades de peso especificadas.
4. Úselo únicamente sobre una superficie plana, nivelada, dura y lisa que pueda
Admite un perchero tipo gabinete completamente cargado .
5. Úselo únicamente según lo previsto.
6. Inspeccione antes de cada uso; no lo utilice si las piezas están sueltas o dañadas.

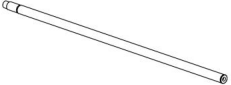
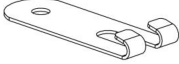
GUARDE ESTE MANUAL

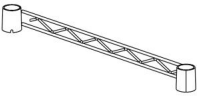
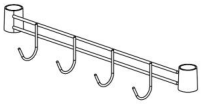
LISTA DE PIEZAS

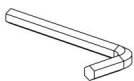
| | | |
|--|--|--|
| <p>A x2</p>  | <p>B x4</p>  | <p>C x8</p>  |
| <p>D x8</p>  | <p>E x8</p>  | <p>F x2</p>  |
| <p>G x1</p>  | <p>H x1</p>  | <p>I x6</p>  |
| <p>J x64+2</p>  | <p>K x2</p>  | <p>L x2</p>  |
| <p>M x2+1</p>  | <p>N x4+1</p>  | <p>x1</p>  |

PASO DE MONTAJE

step 1

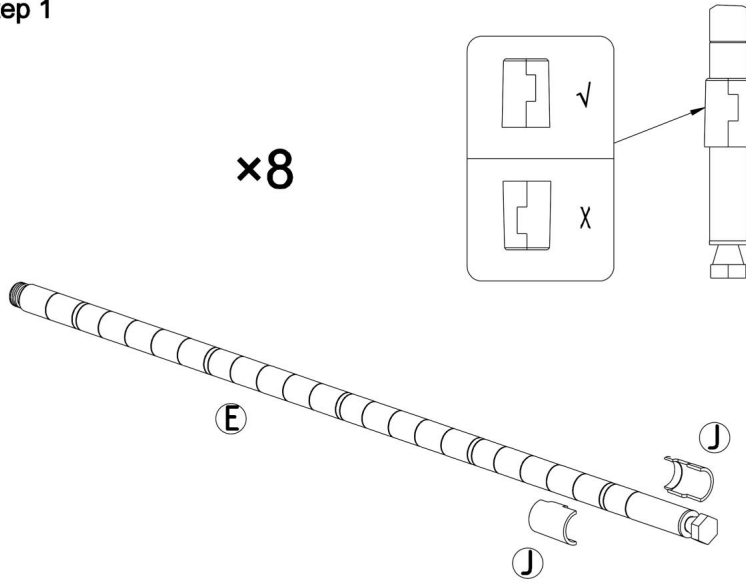

step 2

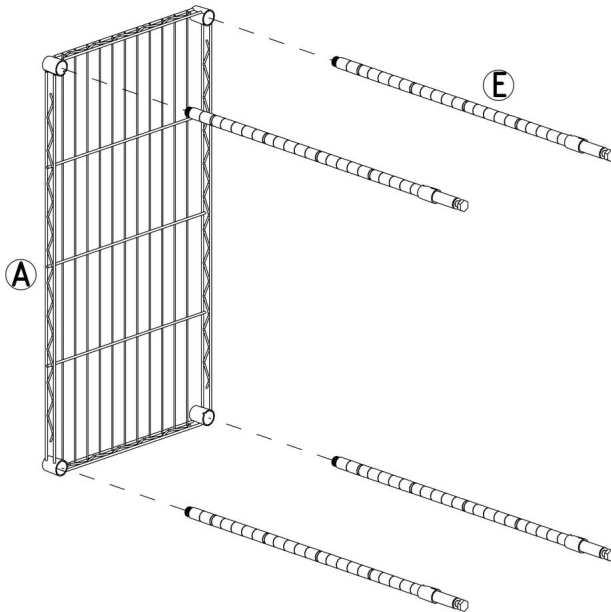

step 3

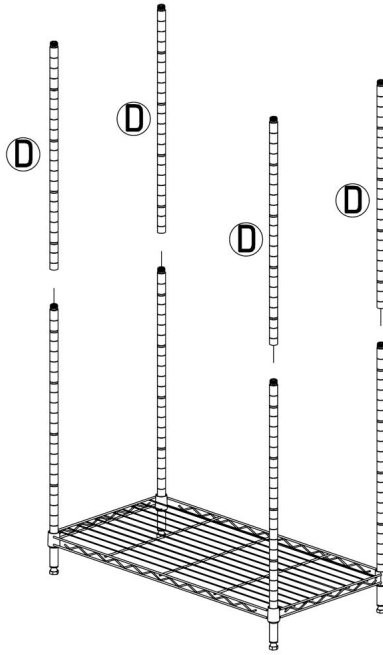

step 4

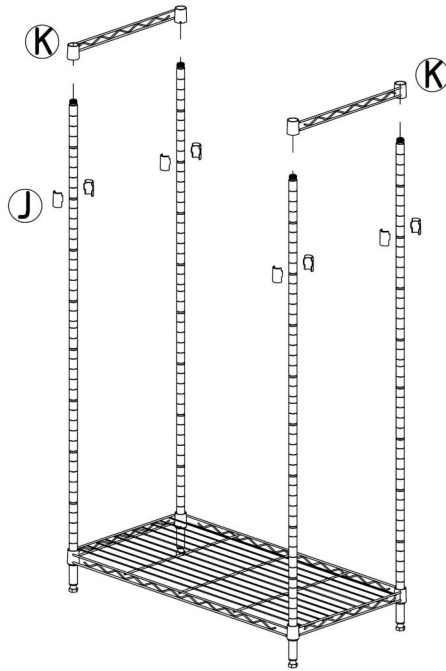

step 5

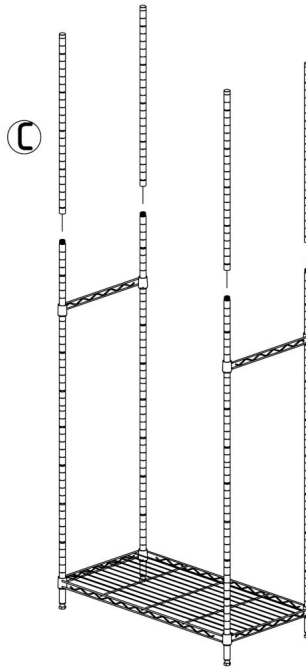

step 6

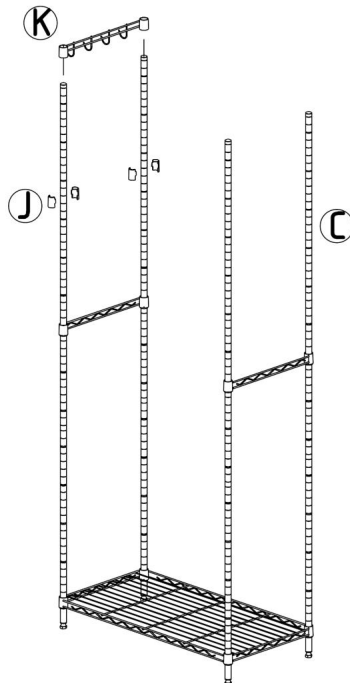

step 7

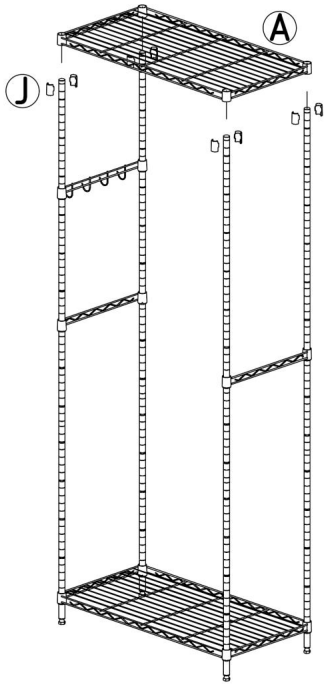

step 8

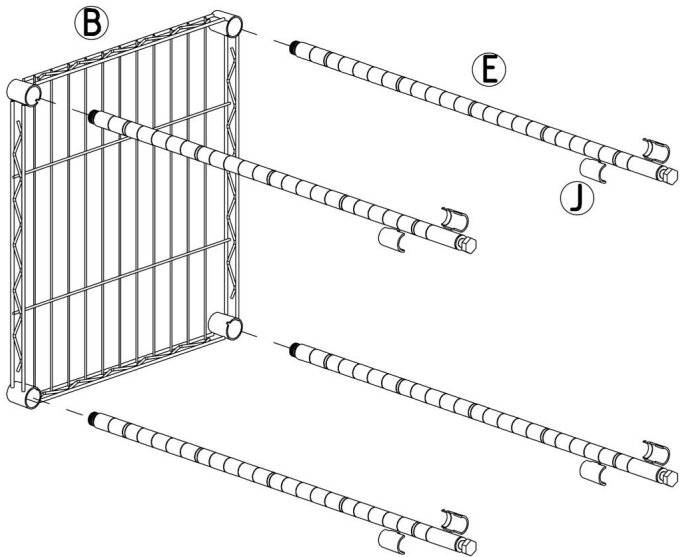

step 9

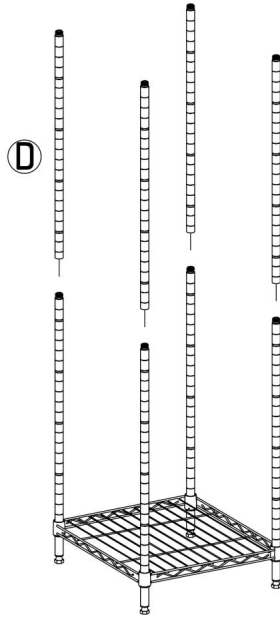

step 10

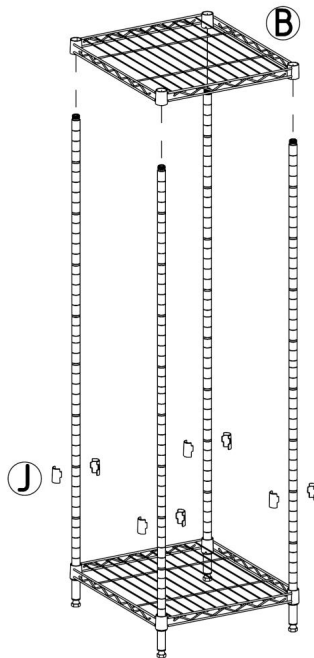

step 11

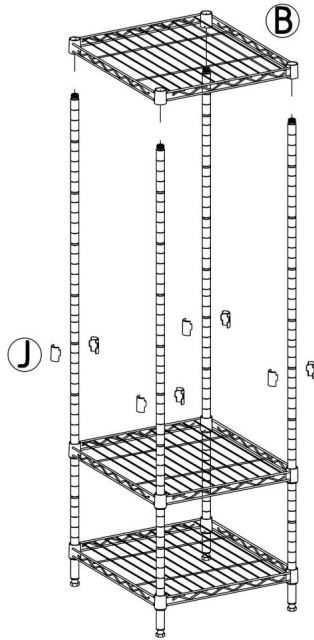

step 12

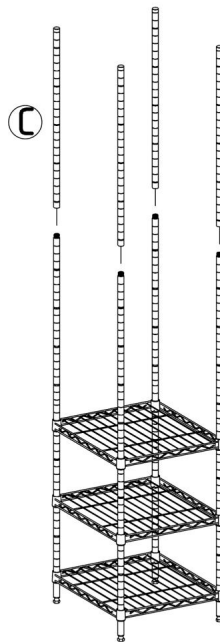

step 13

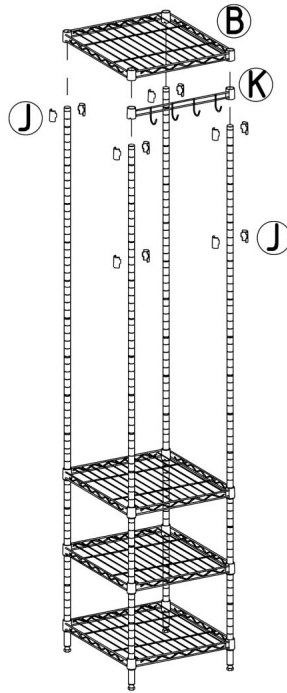

step 14

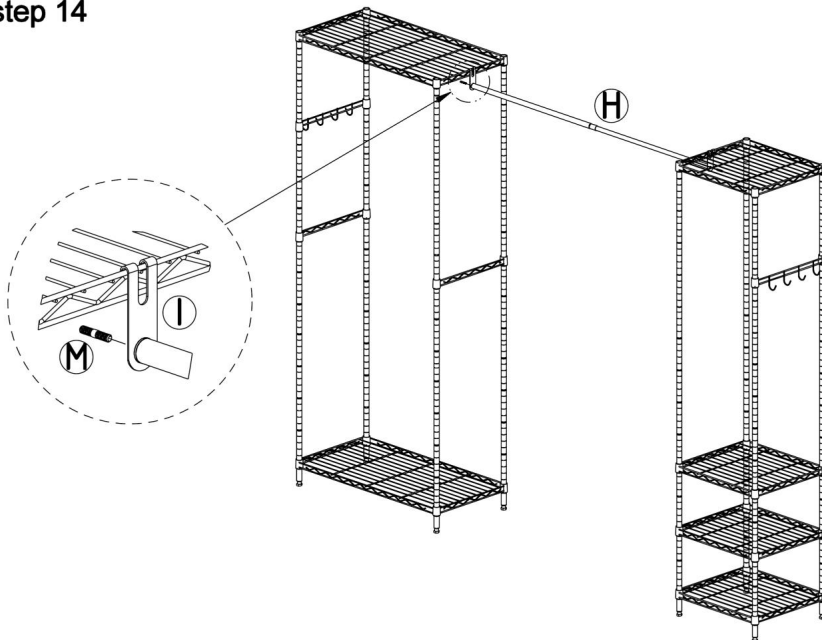

step 15

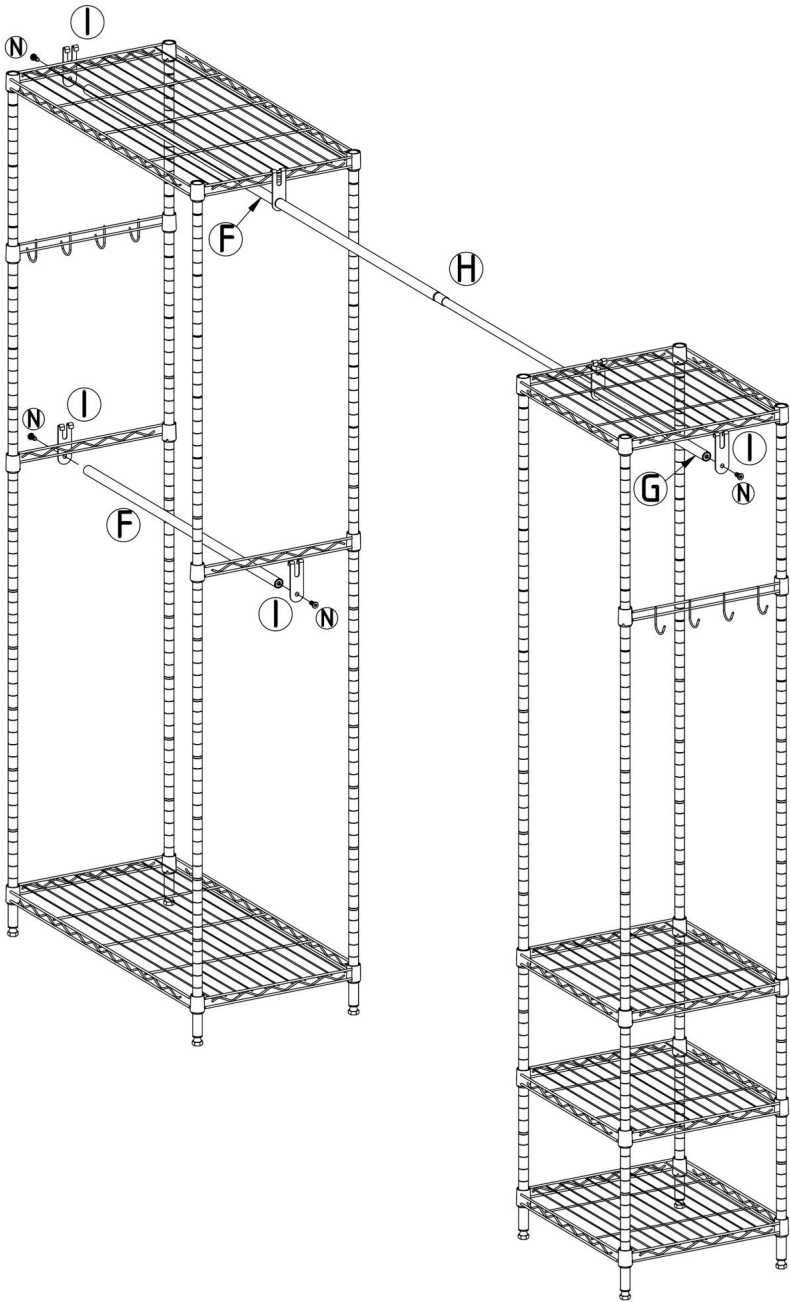

PARÁMETRO DEL PRODUCTO

| | |
|-------------------------|--|
| Modelo | YC0009 |
| Color | Negro |
| Máximo Peso de carga | <p>Peso: hasta 800 libras (363 kg);</p> <p>Red de celosía: 40 kg por pieza (distribución uniforme);</p> <p>Barras fijas para colgar: 30 kg por barra (distribución uniforme);</p> <p>Varillas de extensión para colgar: 10 kg por barra (uniforme) Distribución);</p> <p>Ganchos de fila: 12 kg por fila (distribución uniforme)</p> |
| Tamaño del producto | 2440×380×1803,5 mm |

Fabricante: Shanghaimuxinmuyeyouxiangongsi Dirección:
Shuangchenglu 803nong11hao1602A-1609shi, baoshanqu, shanghai 200000 CN.

Importado a AUS: SIHAO PTY LTD. 1 ROKEVA STREET, EASTWOOD, NSW 2122,
Australia

Importado a EE. UU.: Sanven Technology Ltd. Suite 250, 9166 Anaheim Place,
Rancho Cucamonga, CA 91730



YH CONSULTING LIMITADA. A/C YH Consulting
Limited Oficina 147, Centurion House, London
Road, Staines-upon-Thames, Surrey, TW18 4AX

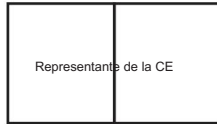

E-CrossStu GmbH
Mainzer Landstr.69,
60329 Fráncfort del Meno.



VEVOR

Affordable. Reliable. Home Improvement.

WIESZAK NA UBRANIA W STYLU SZAFKI

YC0009

MODEL: YC0009

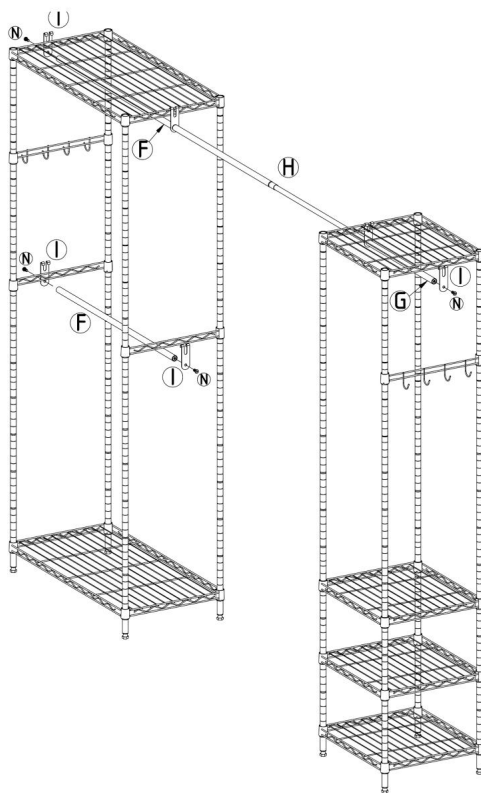

To jest oryginalna instrukcja obsługi. Przed użyciem prosimy o dokładne zapoznanie się z treścią instrukcji. Firma VEVOR zastrzega sobie prawo do jednoznacznej interpretacji niniejszej instrukcji obsługi. Wygląd produktu zależy od stanu, w jakim go otrzymali Państwo. Prosimy o wyrozumiałość, ale nie będziemy Państwa ponownie informować o aktualizacjach technologicznych lub oprogramowania naszego produktu.

INSTRUKCJE BEZPIECZEŃSTWA

OSTRZEŻENIE:

Przed użyciem produktu należy zapoznać się z treścią niniejszego dokumentu. Niezastosowanie się do tego zalecenia może spowodować poważne obrażenia.

Środki ostrożności podczas montażu









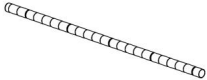

1. Montaż należy wykonywać wyłącznie zgodnie z niniejszą instrukcją. Nieprawidłowy montaż może stwarzać zagrożenie.
2. Noś okulary ochronne zatwierdzone przez ANSI i wytrzymałe rękawice robocze. podczas montażu.
3. Utrzymuj miejsce zgromadzenia w czystości i dobrym oświetleniu.
4. Podczas montażu nie dopuść, aby osoby postronne znajdowały się w pobliżu miejsca montażu.
5. Nie należy gromadzić się, jeśli jest się zmęczonym lub pod wpływem alkoholu, narkotyków lub narkotyków. lub leków.
6. Możliwości produktu dotyczą produktu prawidłowo i całkowicie zmontowanego tylko produkty.
7. Montaż należy wykonać na płaskiej, równej, twardej i gładkiej powierzchni, która będzie bezpieczna. podtrzymujący wieszak na ubrania w stylu szafki.
8. Aby uzyskać dodatkowe informacje dotyczące części wymienionych poniżej, stron, zapoznaj się ze schematem montażu w niniejszej instrukcji. Rozpakuj i oddzielić wszystkie części w czystym miejscu pracy.

Zachowaj środki ostrożności

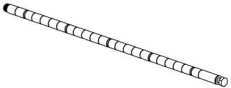
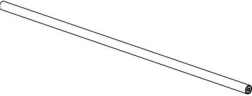
1. NIE WOLNO SIEDZIEĆ ANI STAWAĆ NA TYM PRZEDMIOCIE.
2. Ten produkt nie jest zabawką. Nie pozwalaj dzieciom bawić się nim ani przebywać w jego pobliżu. przedmiot.
3. Nie przekraczać dopuszczalnego obciążenia.
4. Używaj wyłącznie na płaskiej, równej, twardej i gładkiej powierzchni, która może być bezpiecznie używana. obsługuje w pełni załadowany stojak na ubrania w stylu szafki.
5. Używać wyłącznie zgodnie z przeznaczeniem.
6. Przed każdym użyciem należy przeprowadzić kontrolę. Nie należy używać produktu, jeśli jakieś części są luźne lub uszkodzone.

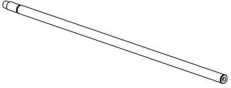
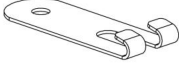
ZAPISZ TĘ INSTRUKCJĘ

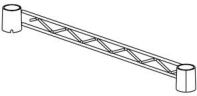
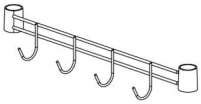
LISTA CZĘŚCI

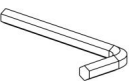
| | | |
|--|--|--|
| <p>A x2</p>  | <p>B x4</p>  | <p>C x8</p>  |
| <p>D x8</p>  | <p>E x8</p>  | <p>F x2</p>  |
| <p>G x1</p>  | <p>H x1</p>  | <p>I x6</p>  |
| <p>J x64+2</p>  | <p>K x2</p>  | <p>L x2</p>  |
| <p>M x2+1</p>  | <p>N x4+1</p>  | <p>x1</p>  |

KROK MONTAŽU

step 1

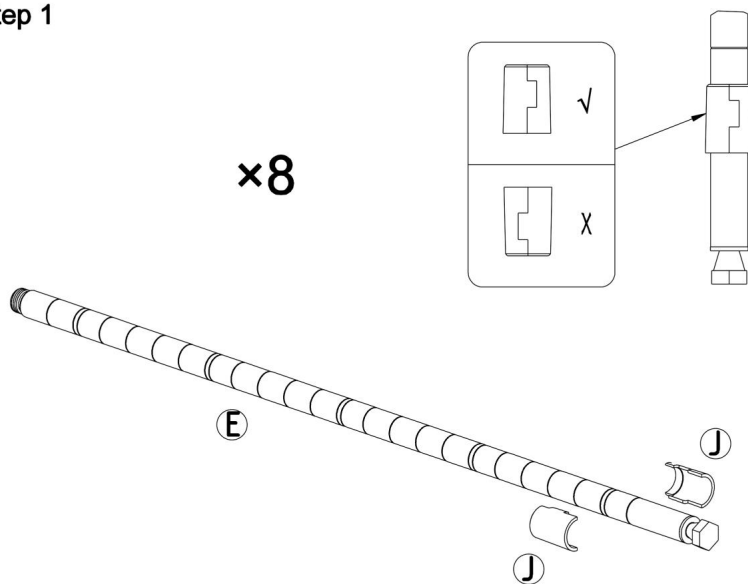

step 2

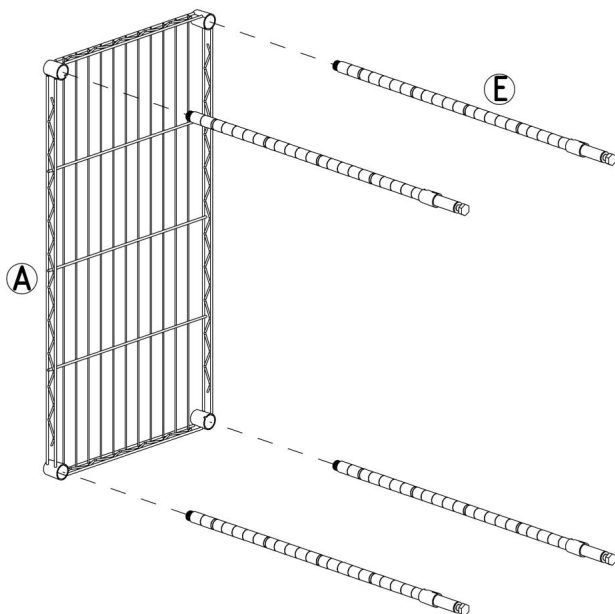

step 3

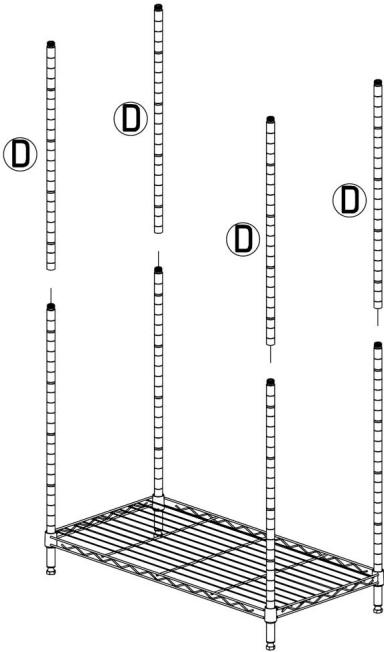

step 4

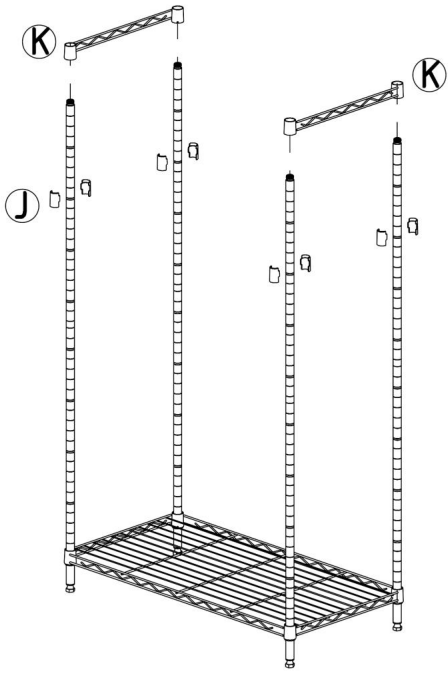

step 5

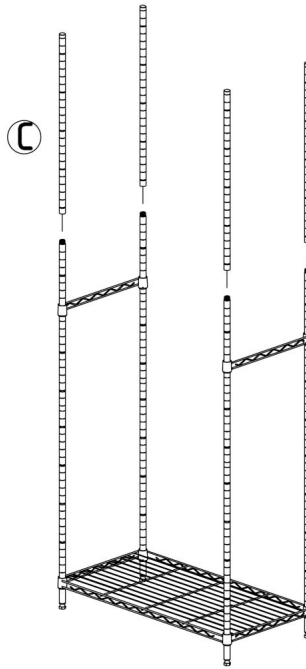

step 6

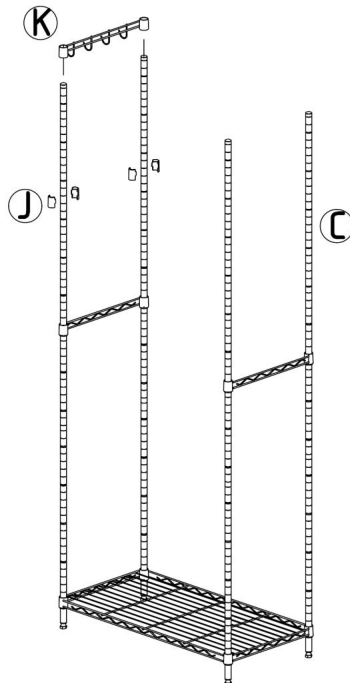

step 7

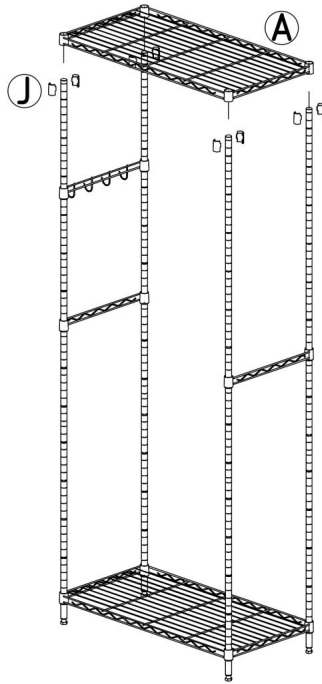

step 8

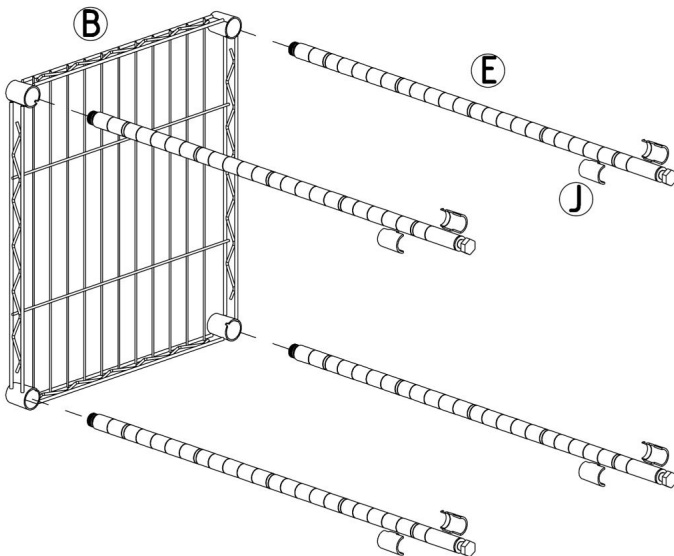

step 9

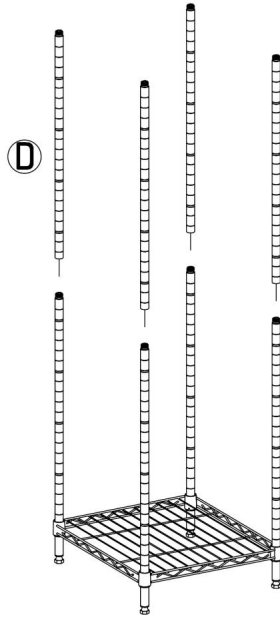

step 10

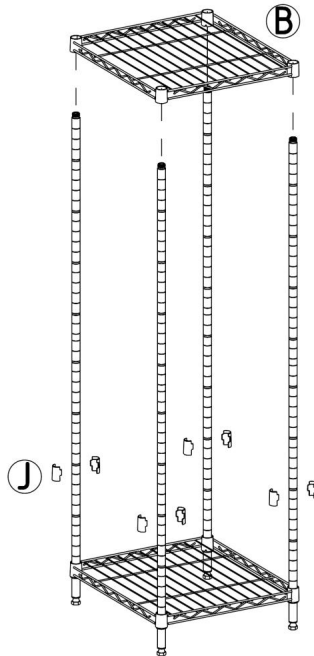

step 11

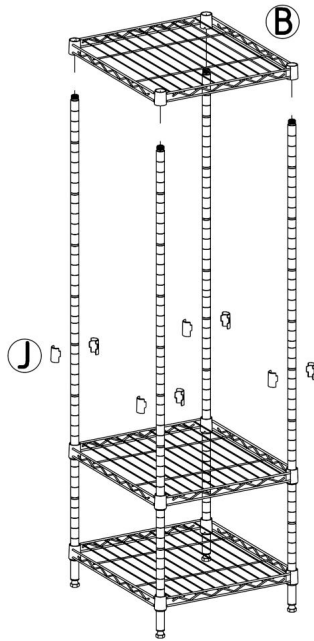

step 12

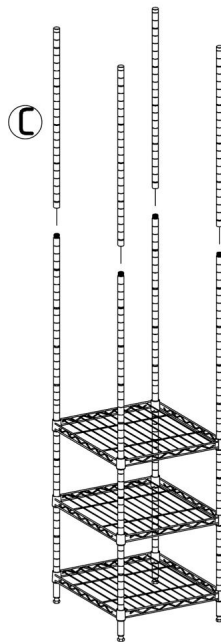

step 13

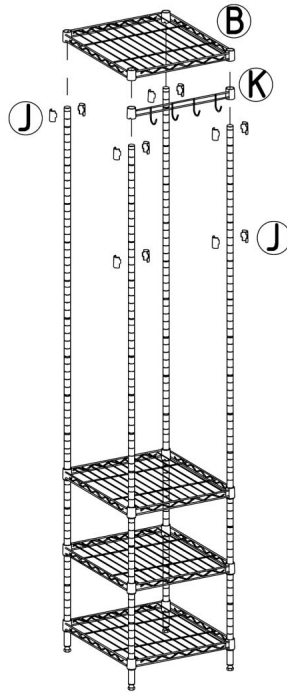

step 14

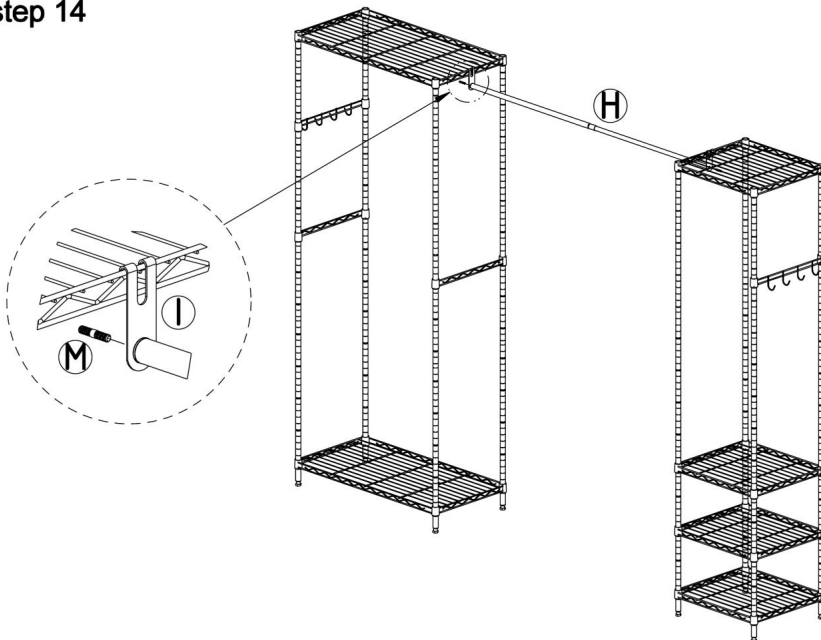

step 15

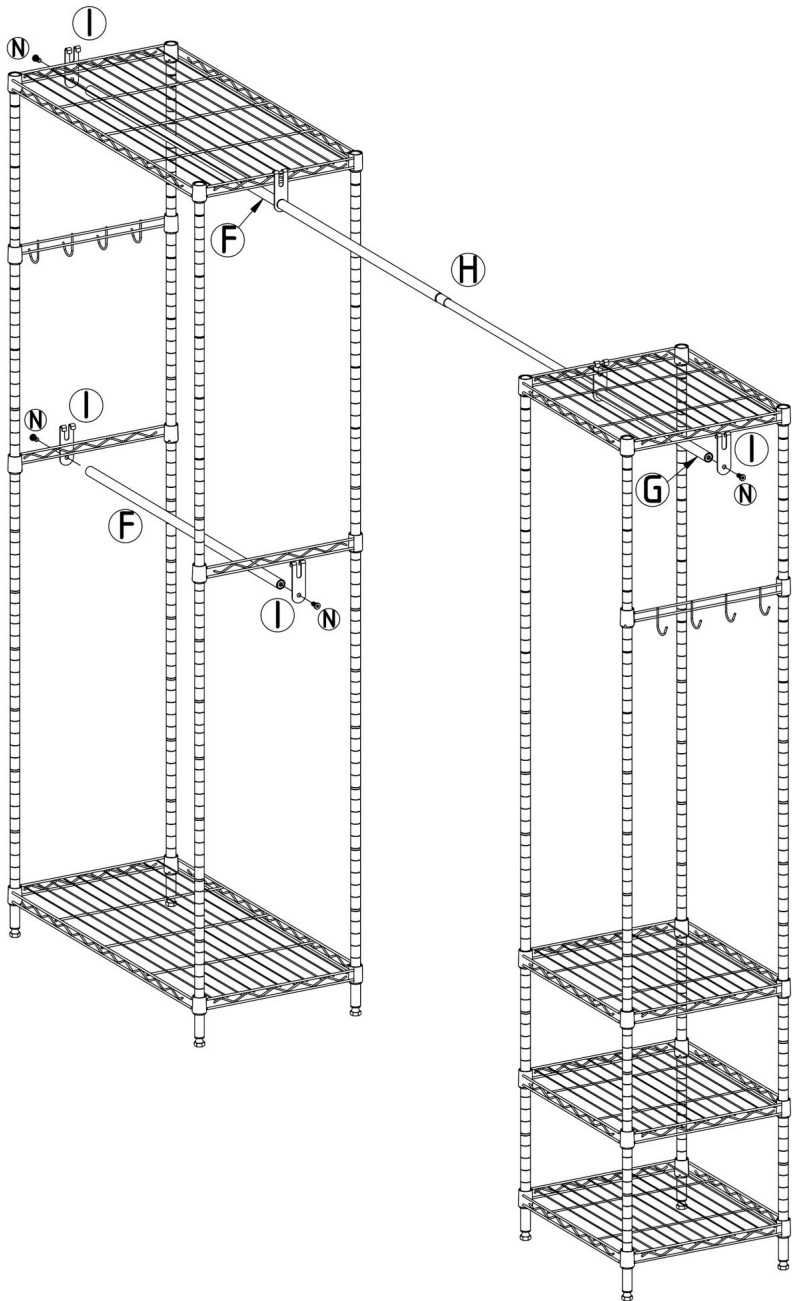

PARAMETR PRODUKTU

| | |
|----------------------------|--|
| Model | YC0009 |
| Kolor | Czarny |
| Maksymalny Waga ładunku | Waga: do 800 funtów (363 kg); Siatka kratowa: 40 kg na sztukę (równomierny rozkład); Pręty wiszące stałe: 30 kg na pręt (równomierny rozkład); Przedłużki do zawieszania: 10 kg na drążek (jednolity) Dystrybucja); Haki rzędowe: 12 kg na rząd (równomierny rozkład) |
| Rozmiar produktu | 2440×380×1803,5 mm |

Producent: Shanghaimuxinmuyeyouxiangongsi Adres:

Shuangchenglu 803nong11hao1602A-1609shi, baoshanqu, szanghaj 200000 CN.

Importowane do Australii: SIHAO PTY LTD. 1 ROKEVA STREETEASTWOOD NSW 2122
Australia

Importowane do USA: Sanven Technology Ltd. Suite 250, 9166 Anaheim Place, Rancho
Cucamonga, CA 91730

| | |
|-----------------------|--|
| REP WIELKIEJ BRYTANII | |
|-----------------------|--|

YH CONSULTING LIMITED. C/O YH Consulting Limited
Biuro 147, Centurion House, London Road, Staines-
upon-Thames, Surrey, TW18 4AX

| | |
|-------------------|--|
| Przedstawiciel WE | |
|-------------------|--|

E-CrossStu GmbH
Mainzer Landstr.69,
60329 Frankfurt nad Menem.



VEVOR

Affordable. Reliable. Home Improvement.

KLEDINGREK IN KASTSTIJL

YC0009

MODEL: YC0009

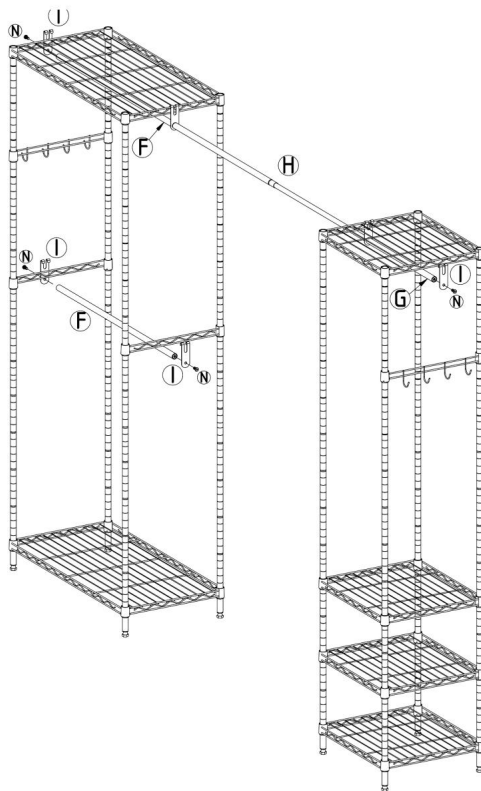

Dit is de originele handleiding. Lees alle instructies zorgvuldig door voordat u het product gebruikt. VEVOR behoudt zich het recht voor om de gebruiksaanwijzing duidelijk te interpreteren. Het uiterlijk van het product is afhankelijk van het product dat u hebt ontvangen. Neemt u het ons niet kwalijk dat we u niet meer op de hoogte stellen van eventuele technologische of software-updates voor ons product.

VEILIGHEIDSINSTRUCTIES

WAARSCHUWING:

Lees dit materiaal voordat u dit product gebruikt. Als u dit niet doet, kan dit leiden tot: ernstig letsel tot gevolg hebben.

Voorzorgsmaatregelen voor montage









1. Monteer uitsluitend volgens deze instructies. Onjuiste montage kan gevaren opleveren.
2. Draag een ANSI-goedgekeurde veiligheidsbril en stevige werkhandschoenen tijdens de montage.
3. Zorg ervoor dat de verzamelplaats schoon en goed verlicht is.
4. Houd omstanders uit de buurt tijdens de montage.
5. Niet instappen als u moe bent of onder invloed van alcohol of drugs. of medicijnen.
6. De producteigenschappen gelden voor correct en volledig gemonteerde producten. alleen producten.
7. Monteer op een vlak, vlak, hard en glad oppervlak waarop u veilig kunt ter ondersteuning van het kledingrek in kaststijl.
8. Voor aanvullende informatie over de onderdelen die in de volgende lijst staan vermeld, Voor meer informatie over de montage, zie het montageschema van deze handleiding. Uitpakken en scheid alle onderdelen in een schone werkruimte.

Gebruik voorzorgsmaatregelen

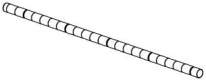
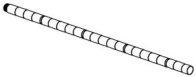
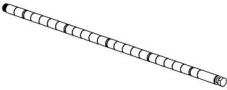
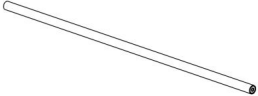
1. NIET OP DIT ITEM ZITTEN OF STAAN.
2. Dit product is geen speelgoed. Laat kinderen niet met of in de buurt van dit product spelen. item.
3. Overschrijd het aangegeven gewicht niet.
4. Gebruik het alleen op een vlak, egaal, hard en glad oppervlak dat veilig kan worden gebruikt. een volledig uitgeruste kledingrek in kaststijl ondersteunen.
5. Gebruik het product alleen zoals bedoeld.
6. Controleer het product voor elk gebruik. Gebruik het product niet als er onderdelen loszitten of beschadigd zijn.

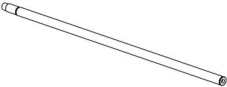
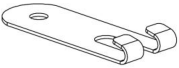
BEWAAR DEZE HANDLEIDING

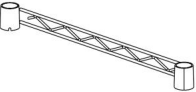
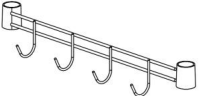
ONDERDELENLIJST

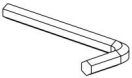
| | | |
|--|--|--|
| <p>A x2</p>  | <p>B x4</p>  | <p>C x8</p>  |
| <p>D x8</p>  | <p>E x8</p>  | <p>F x2</p>  |
| <p>G x1</p>  | <p>H x1</p>  | <p>I x6</p>  |
| <p>J x64+2</p>  | <p>K x2</p>  | <p>L x2</p>  |
| <p>M x2+1</p>  | <p>N x4+1</p>  | <p>x1</p>  |

MONTAGESTAP

step 1

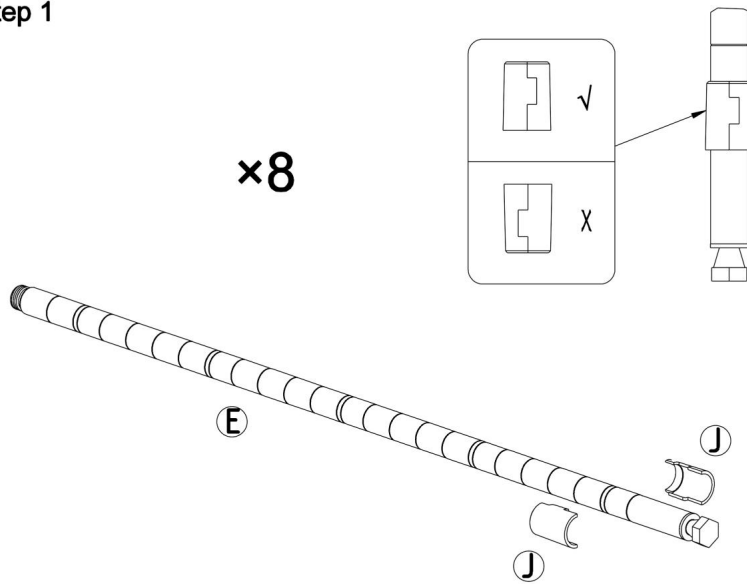

step 2

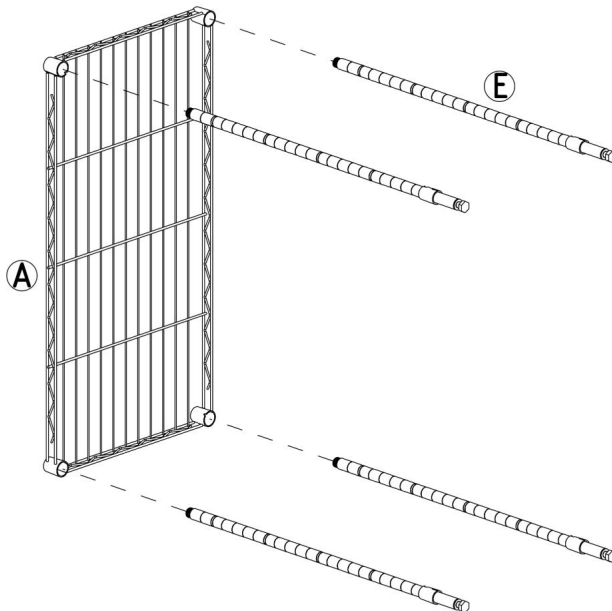

step 3

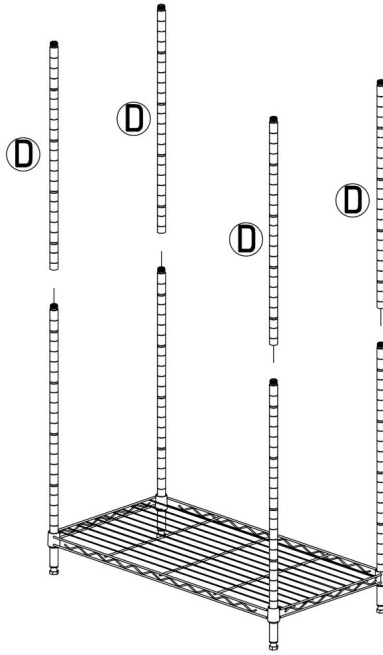

step 4

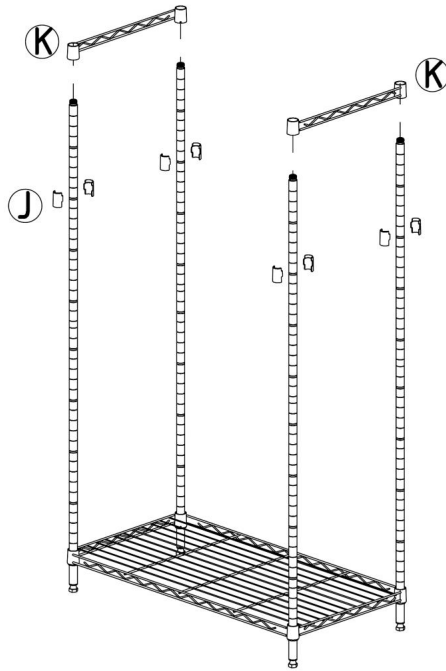

step 5

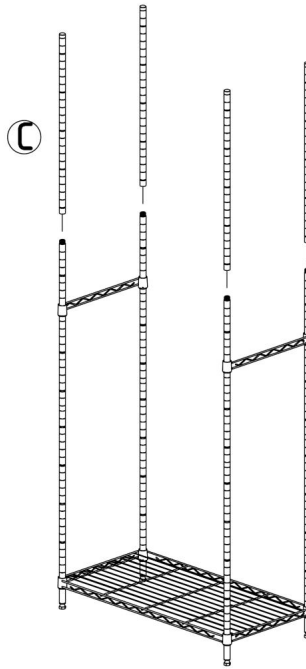

step 6

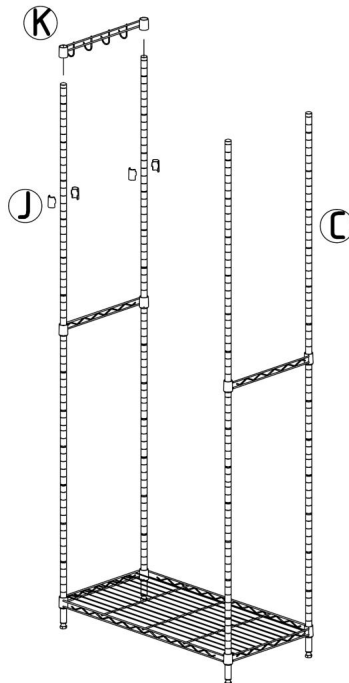

step 7

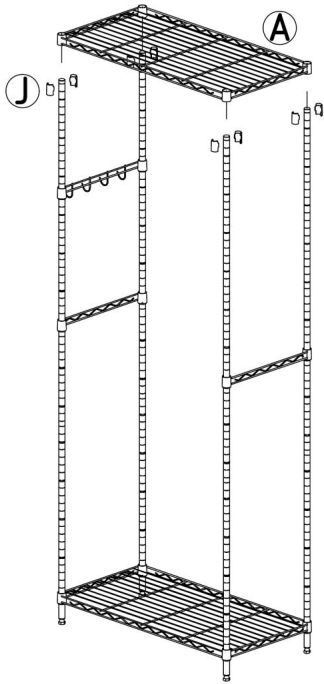

step 8

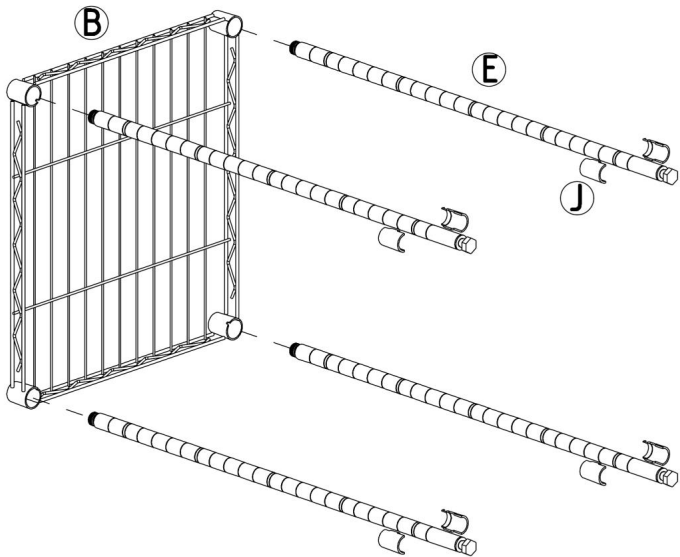

step 9

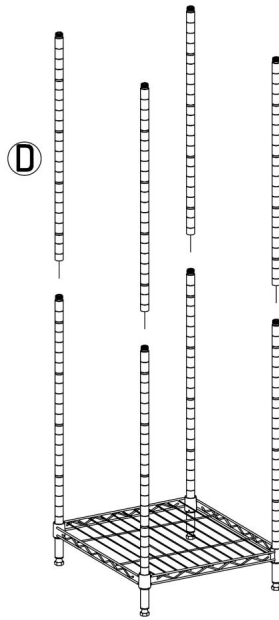

step 10

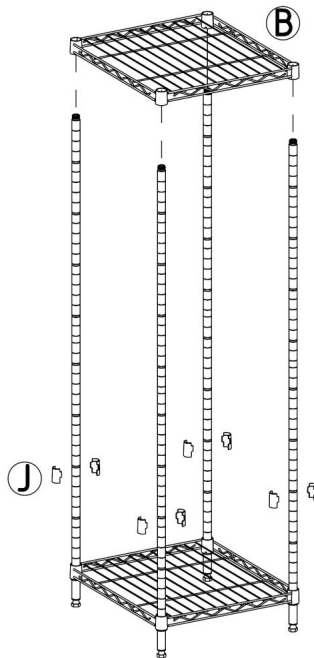

step 11

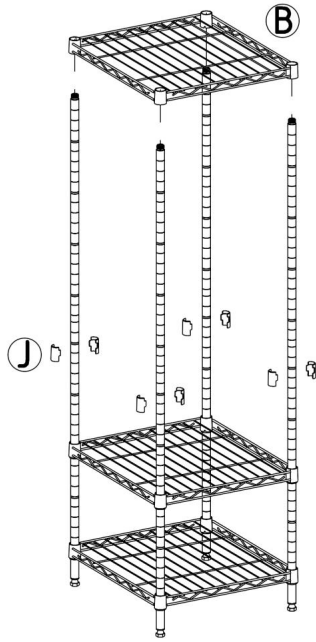

step 12

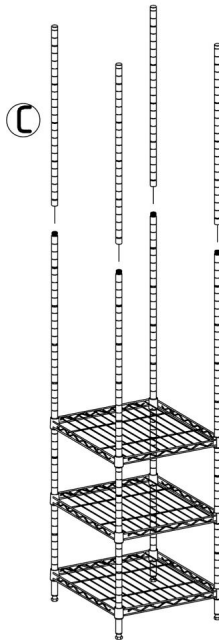

step 13

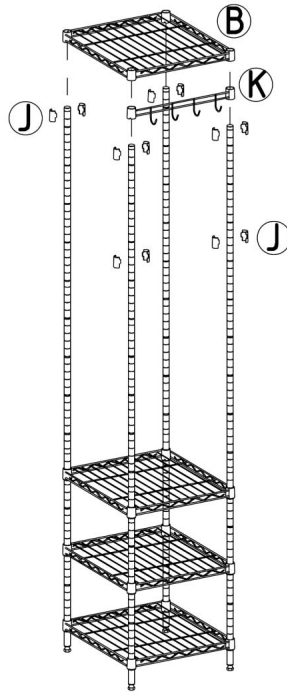

step 14

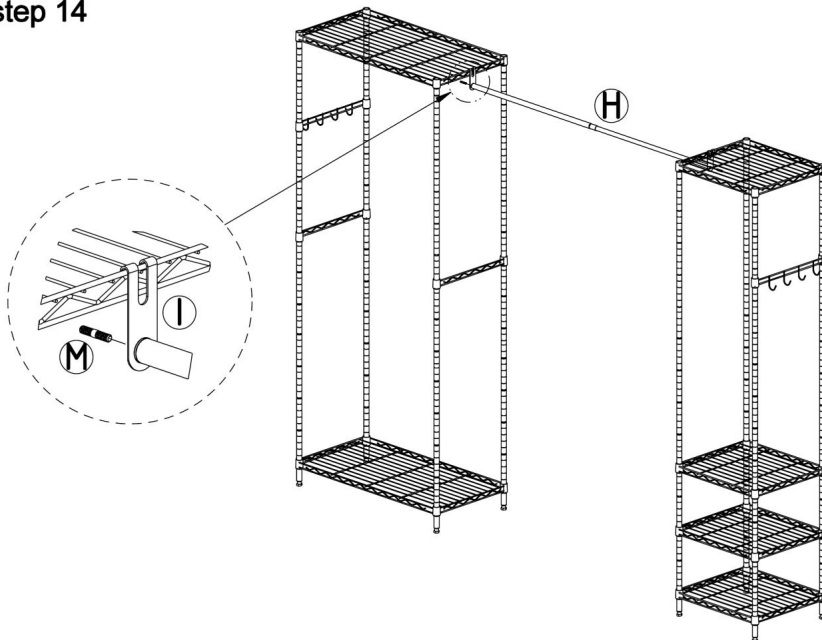

step 15

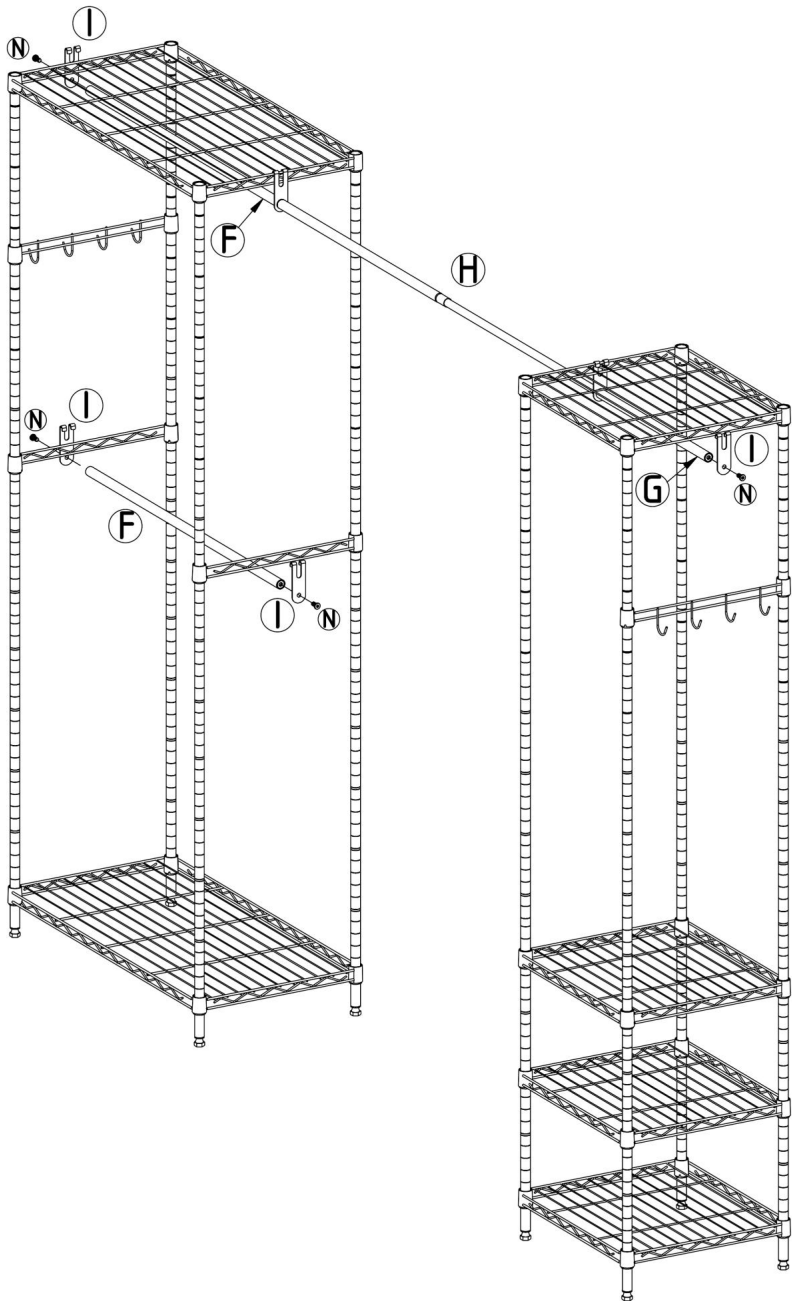

PRODUCTPARAMETER

| | |
|-----------------------------|--|
| Model | YC0009 |
| Kleur | Zwart |
| Maximaal Laadgewicht | Gewicht: tot 800 pond (363 kg); Traliewerk: 40 kg per stuk (gelijkmatige verdeling); Vaste hangstangen: 30 kg per staaf (gelijkmatige verdeling); Verlengbare hangstangen: 10 kg per staaf (uniform) Verdeling); Rijhaken: 12 kg per rij (gelijkmatige verdeling) |
| Productgrootte | 2440x380x1803,5 mm |

Fabrikant: Shanghaimuxinmuyeyouxiangongsi **Adres:**

Shuangchenglu 803nong11hao1602A-1609shi, baoshanqu, shanghai 200000 CN.

Geïmporteerd naar AUS: SIHAO PTY LTD. 1 ROKEVA STREETEASTWOOD NSW
2122 Australië

Geïmporteerd naar de VS: Sanven Technology Ltd. Suite 250, 9166 Anaheim Place,
Rancho Cucamonga, CA 91730



YH CONSULTING LIMITED. T.a.v. YH Consulting
Limited Kantoor 147, Centurion House, London
Road, Staines-upon-Thames, Surrey, TW18 4AX



E-CrossStu GmbH
Mainzer Landstr.69,
60329 Frankfurt am Main.



VEVOR

Affordable. Reliable. Home Improvement.

Klädställ i skåpstil

YC0009

MODELL: YC0009

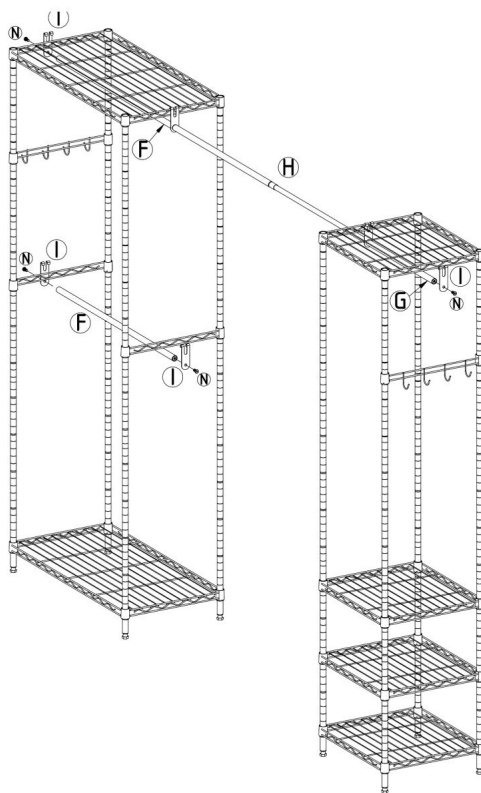

Detta är originalinstruktionerna, vänligen läs alla instruktioner noggrant innan du använder produkten. VEVOR förbehåller sig en tydlig tolkning av vår användarmanual. Produktens utseende ska vara beroende av den produkt du mottagit. Vi ber om ursäkt för att vi inte kommer att informera dig igen om det finns några teknik- eller programuppdateringar för vår produkt.

SÄKERHETSINSTRUKTIONER

VARNING:

Läs detta material innan du använder produkten. Underlåtenhet att göra det kan resultera i allvarliga skador.

Monteringsförsiktighetsåtgärder











1. Montera endast enligt dessa instruktioner. Felaktig montering kan skapa faror.
2. Använd ANSI-godkända skyddsglasögon och kraftiga arbetshandskar under monteringen.
3. Håll samlingsområdet rent och väl upplyst.
4. Håll åskådare borta från området under monteringen.
5. Montera inte om du är trött eller påverkad av alkohol eller droger eller medicinering.
6. Produktens egenskaper gäller för korrekt och fullständigt monterade endast produkter.
7. Montera på en plan, jämn, hård och slät yta som säkert kan användas stödjer klädhyllan i skåpstil.
8. För ytterligare information om de delar som listas i följande sidor, vänligen se monteringsdiagrammet i denna manual. Packa upp och separera alla delar på en ren arbetsyta.

Använd försiktighetsåtgärder

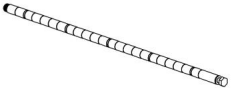
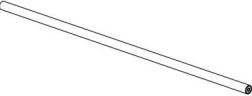
1. SITTA ELLER STÅ INTE PÅ DENNA FÖRENING.
2. Denna produkt är inte en leksak. Låt inte barn leka med eller i närheten av denna punkt.
3. Överskrid inte angivna viktkapaciteter.
4. Använd endast på en plan, jämn, hård och slät yta som säkert kan stödja en fullt utrustad klädhylla i skåpstil.
5. Använd endast enligt avsikten.
6. Kontrollera före varje användning; använd inte om delar är lösa eller skadade.

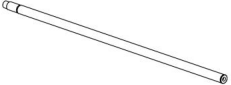
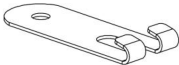
SPARA DENNA HANDBOK

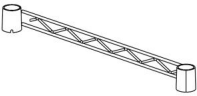
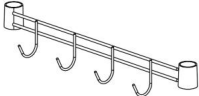
DELLISTA

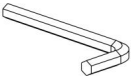
| | | |
|--|--|--|
| <p>A x2</p>  | <p>B x4</p>  | <p>C x8</p>  |
| <p>D x8</p>  | <p>E x8</p>  | <p>F x2</p>  |
| <p>G x1</p>  | <p>H x1</p>  | <p>I x6</p>  |
| <p>J x64+2</p>  | <p>K x2</p>  | <p>L x2</p>  |
| <p>M x2+1</p>  | <p>N x4+1</p>  | <p>x1</p>  |

MONTERINGSSTEG

step 1

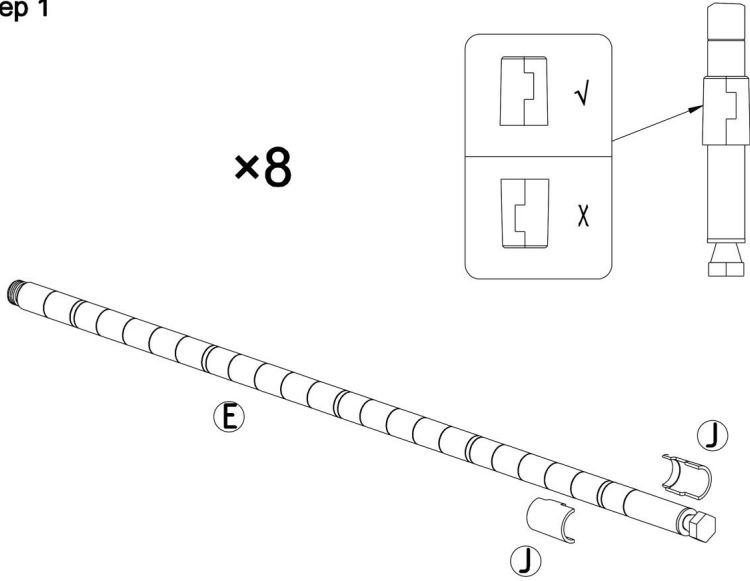

step 2

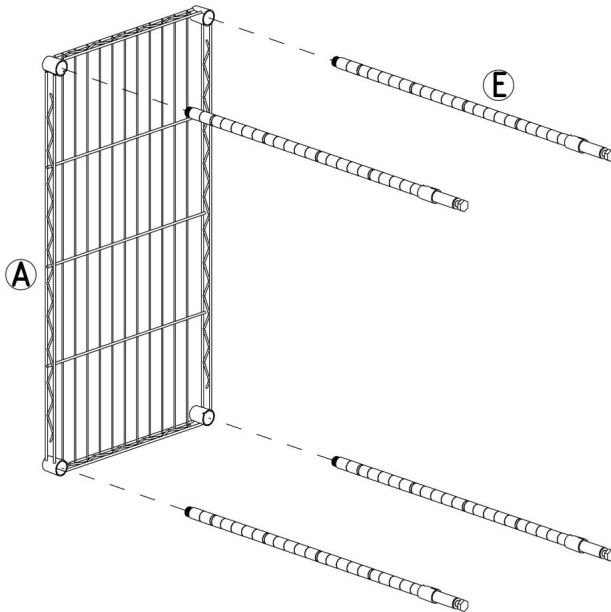

step 3

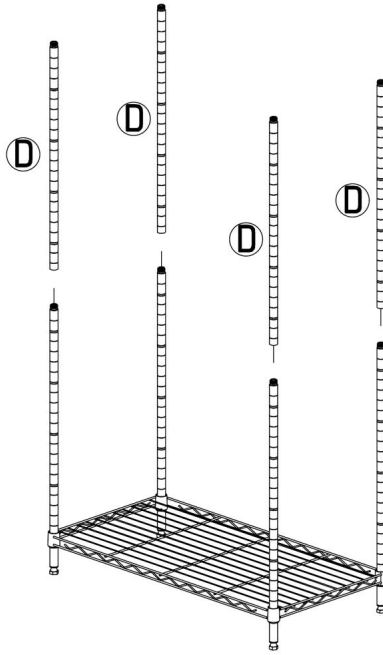

step 4

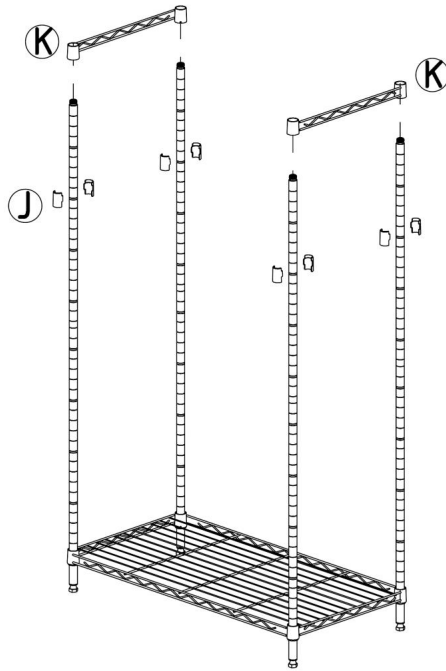

step 5

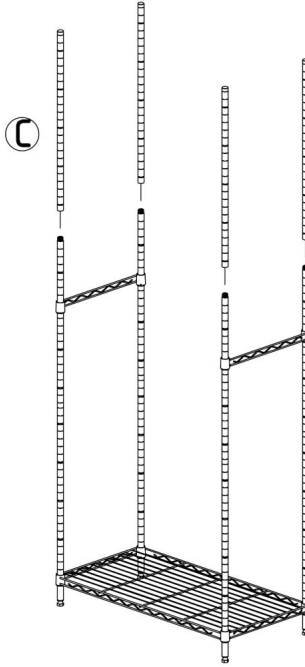

step 6

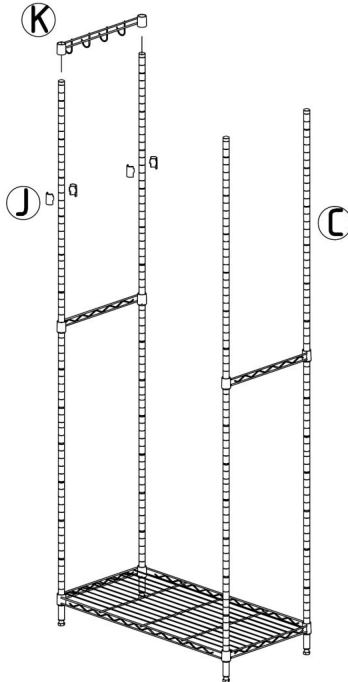

step 7

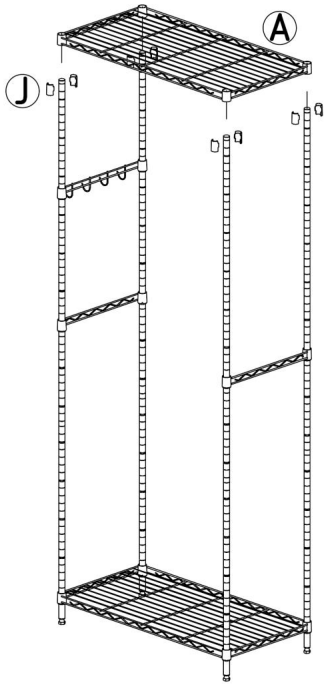

step 8

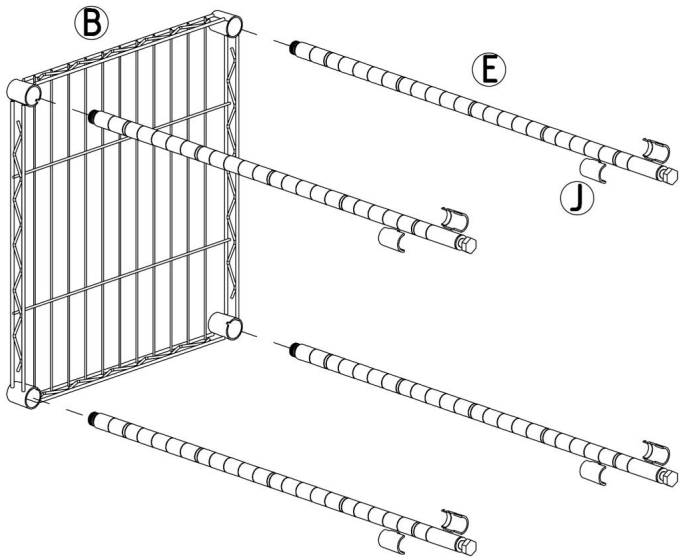

step 9

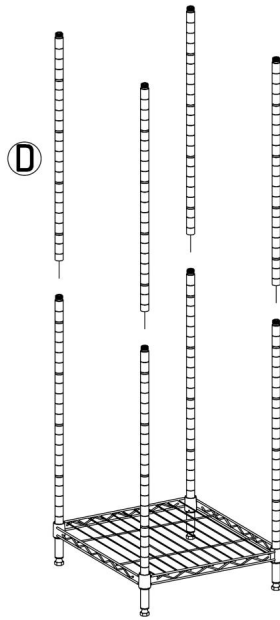

step 10

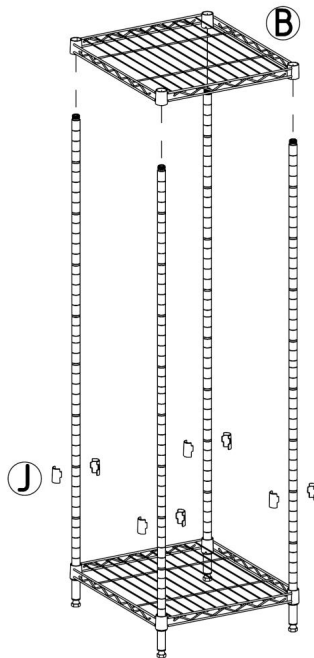

step 11

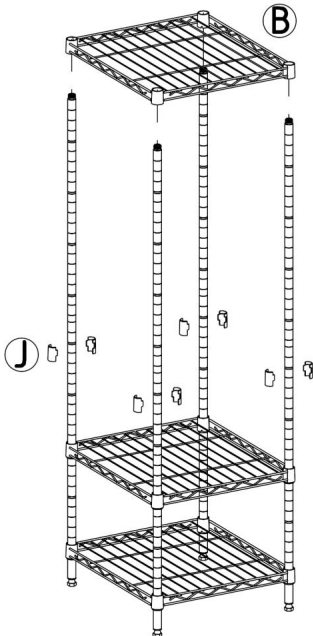

step 12

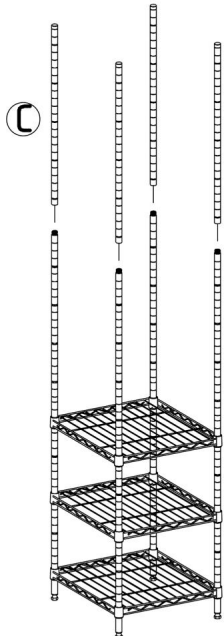

step 13

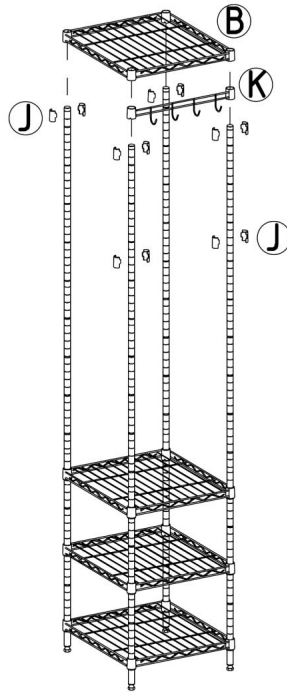

step 14

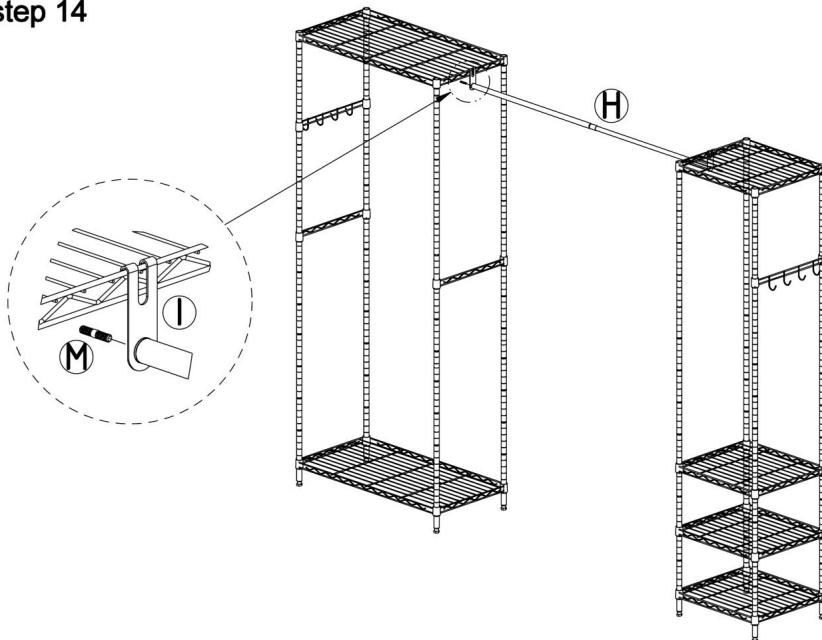

step 15

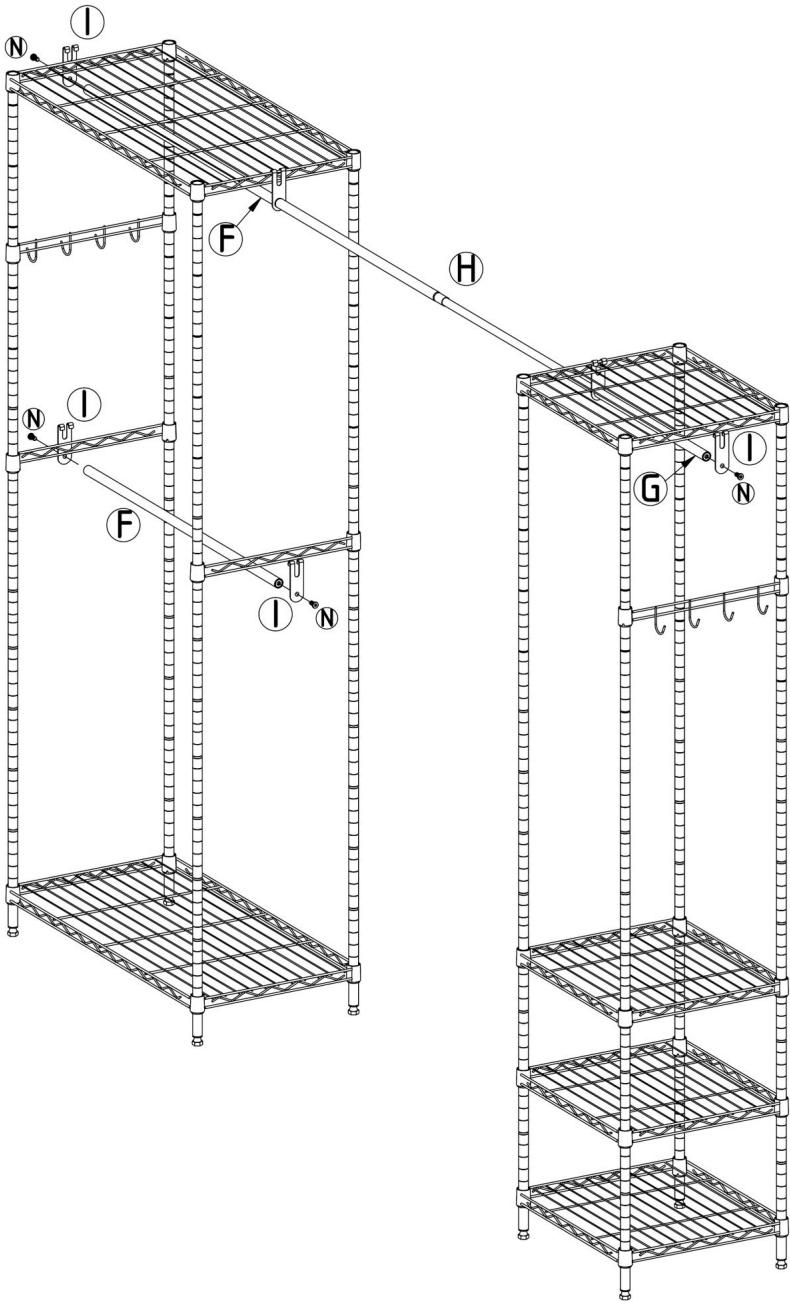

PRODUKTPARAMETER

| | |
|-------------------------|---|
| Modell | YC0009 |
| Färg | Svart |
| Maximal Lastvikt | Vikt: Upp till 363 kg; Gallernät: 40 kg per styck (jämn fördelning); Fasta upphängningsstänger: 30 kg per stång (jämn fördelning); Förlängningshängstänger: 10 kg per stång (jämnvikt) Distribution); Roddkrokar: 12 kg per rad (jämn fördelning) |
| Produktstorlek | 2440×380×1803,5 mm |

Tillverkare: Shanghaimuxinmuyeyouxiangongsi **Adress:**

Shuangchenglu 803nong11hao1602A-1609shi, baoshanqu, shanghai 200000 CN.

Importerad till Australien: SIHAO PTY LTD. 1 ROKEVA STREETEASTWOOD NSW
2122 Australien

Importerad till USA: Sanven Technology Ltd. Suite 250, 9166 Anaheim Place,
Rancho Cucamonga, CA 91730

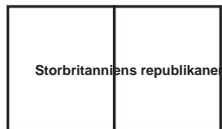

YH CONSULTING LIMITED. C/O YH Consulting
Limited Kontor 147, Centurion House, London
Road, Staines-upon-Thames, Surrey, TW18 4AX

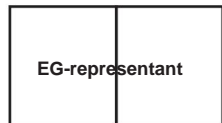

E-CrossStu GmbH
Mainzer Landstr. 69,
60329 Frankfurt am Main.

