

Assembly Instruction



 Team
Assembly
Recommended

Table and Chair Components



Note: Don't tighten all screws during installation.

Componets

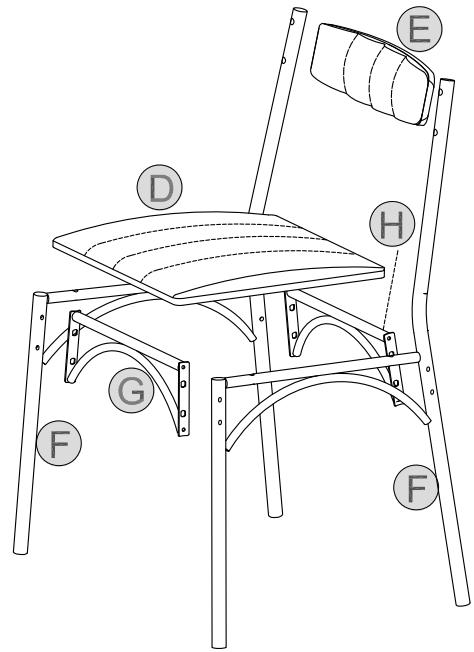
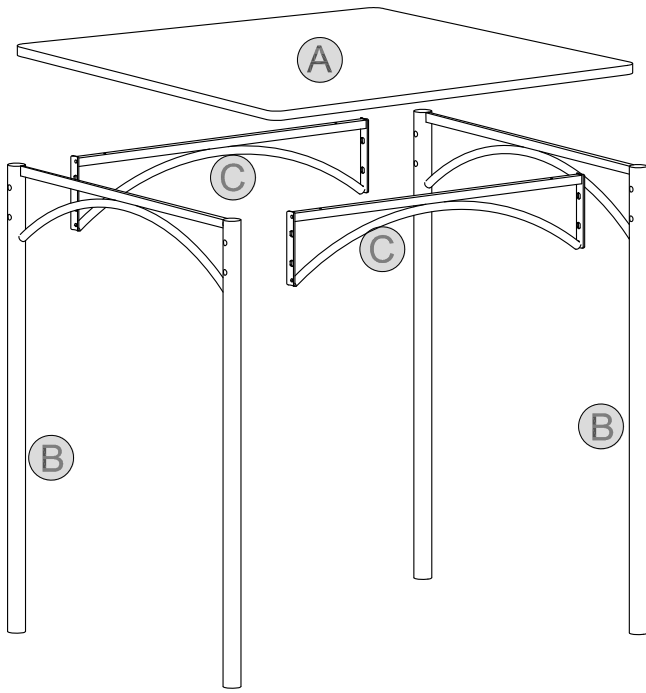
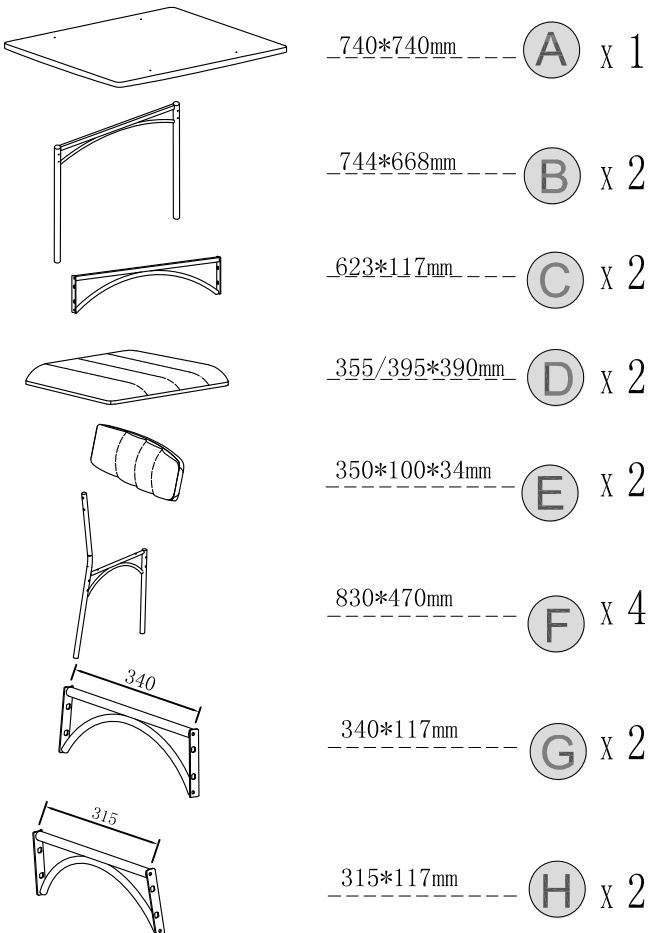

Screws & Tools

1		M6*30mm	X24
2		M6*32mm	X 4
3		M6*35mm	X 16
4		M6	X 24
5		M10	X 1
6		4mm	X 1

Check all the components & screws before assembly.
Do not install in case part is missing, contact us to get.

Step1:

Fasten the frames (B) and (C) together with screws (3) and (4) as shown.

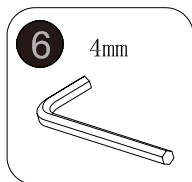
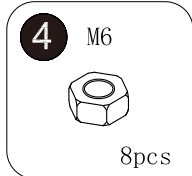
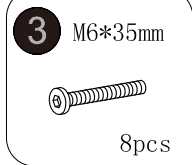
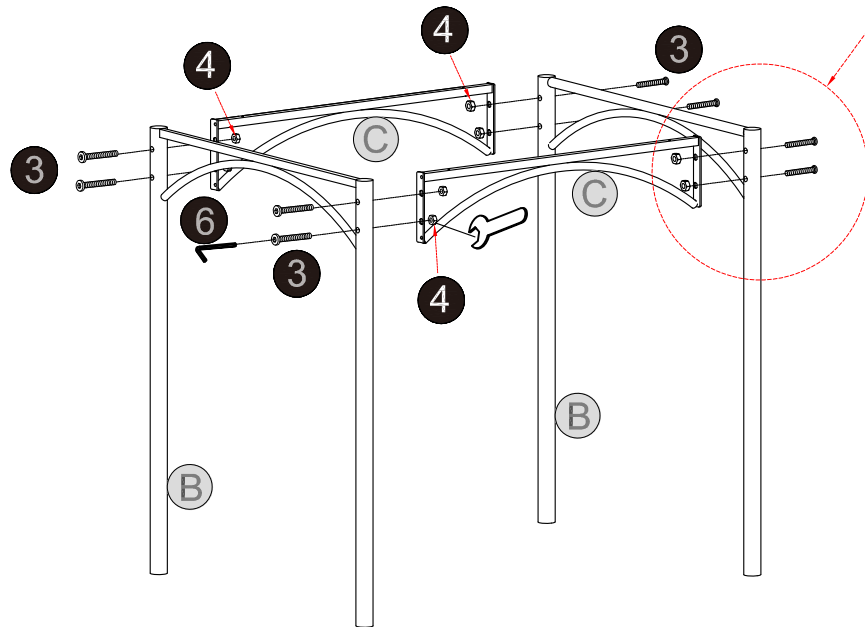

Step2: Use screw (2) to secure the frame installed in Step 1 to the table top (A), as shown.

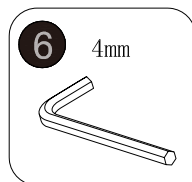
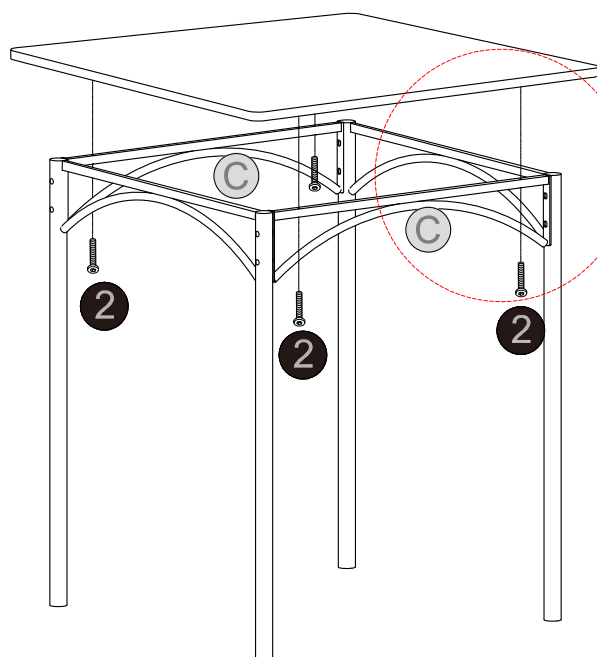

Step3: Fasten the back of the chair (E) and the frame on both sides of the chair (F) together with screws (3). As shown, the back of the chair with the arrow pointing up.

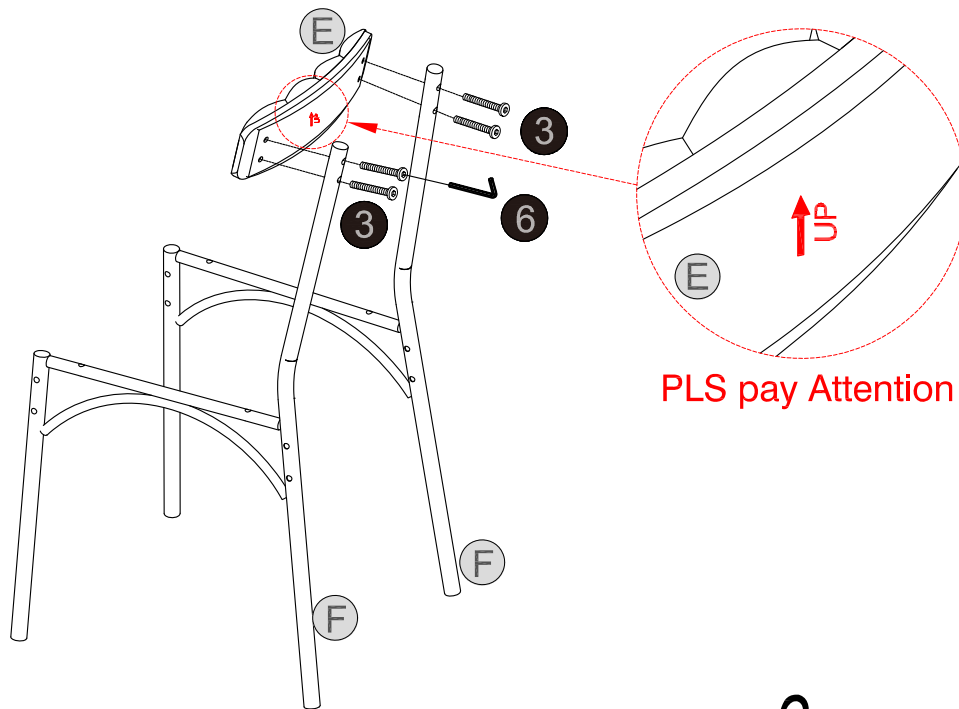
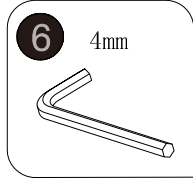
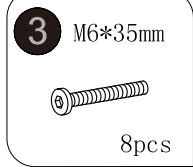

PLS pay Attention!

x 2

Step4: Use screws (1) and (4) to fix the frame (H) and the frame on both sides of the chair together. As shown.

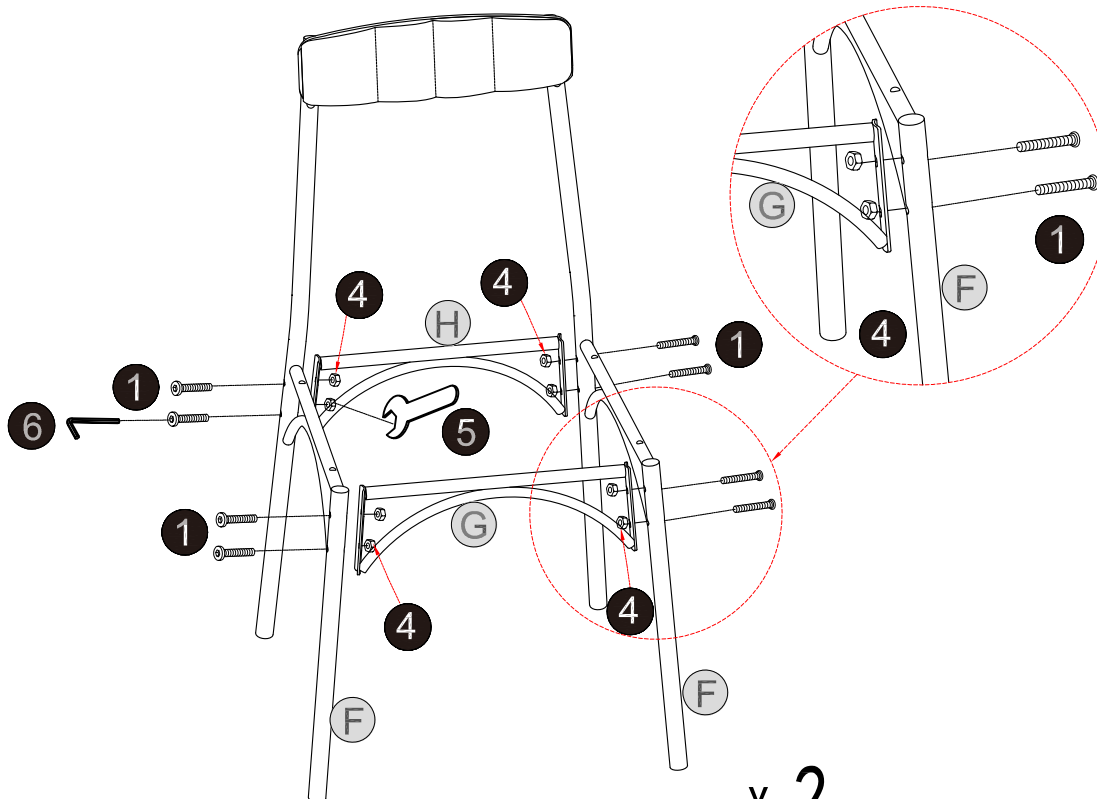
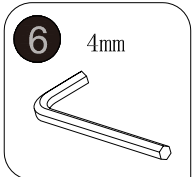
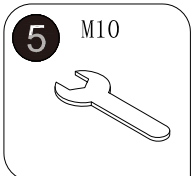
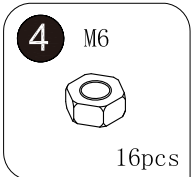
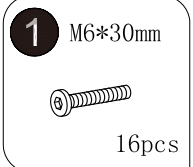

x 2

Step5: Attach the chair cushion (D) to the chair frame with screws (1). Install the chair cushion in the direction of the arrow as shown in the picture.

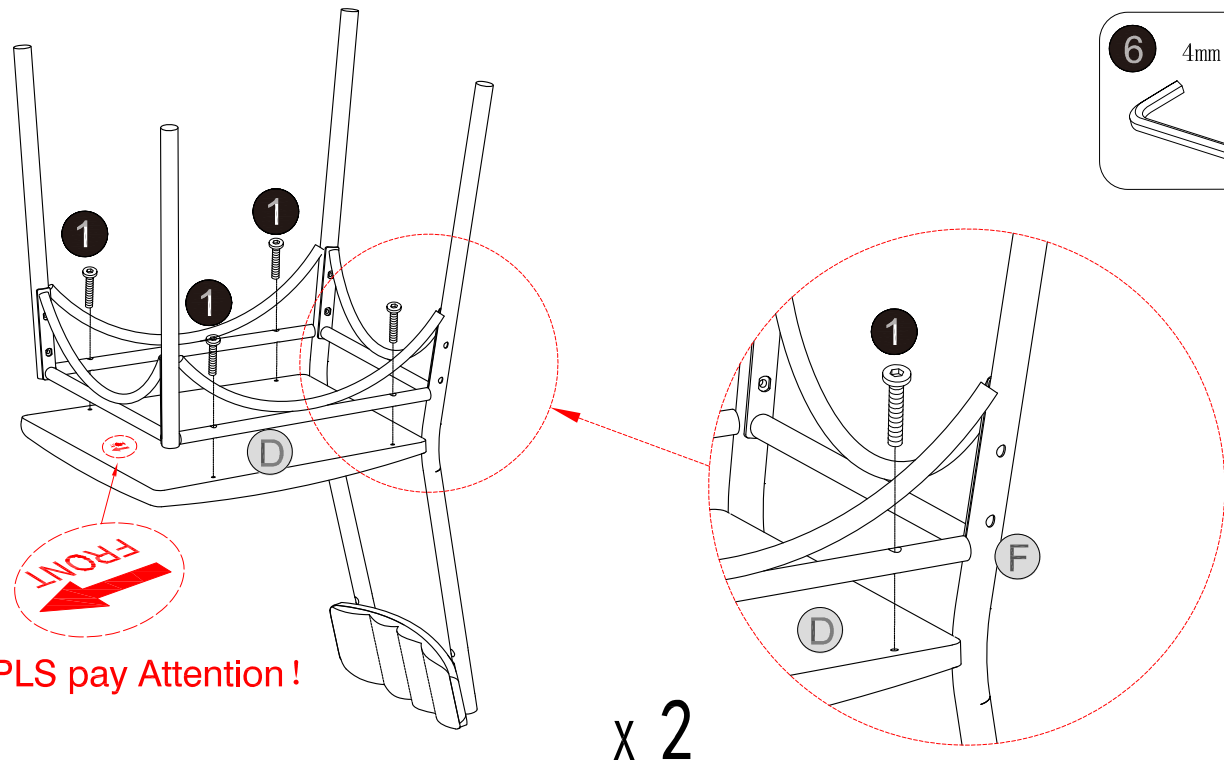
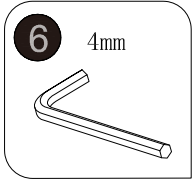
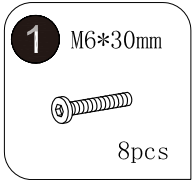

Note:Pls check and tighten all screws.

IMPORTANT SAFETY INFORMATION

Please carefully read the instructions and caution warnings below before assembling the product. Following this guide will ensure that you install, use and maintain the product properly.

- Please keep this installation and user manual/instructions for future reference in case you need to assemble the product.
- Do not assemble if you notice serious damage such as cracks or bends.
- During installation, please use work gloves for hand safety.
- Please assemble the unit on carpeted floor or the flat cardboard box to avoid scratching the surface or your floor while assembling on the floor.
- To assemble, please use the complimentary installation tools (Allen Wrench). Pay more attention to the direction of components at each steps.
- It is recommended that two people work together to assemble the product.
- Please do not tighten the screws up too much, just to 80% before you finish to make the installation go on successfully.

HOW TO MAINTAIN YOUR PRODUCT:

- Check the screws of the product are not loose from regular use.
- Do not use sharp instruments, rubbing alcohol, corrosive chemicals, or abrasive cleaners to clean the product.
- Do not keep the product in a damp environment for a long period of time. The damp environment may cause the iron components to rust and the plates to bulge and crack.