

材质: 105g铜版纸

尺寸: 100\*140 mm

印刷: 单黑双面印刷

装订方式: 折页

# Manual

Floor Lamp

## Introduction

Thank you for choosing our floor lamp. Please read this user manual carefully and keep it for future reference.

## Package Contents

- Remote control LED Bulb x1
- Remote control with Magnet x1
- AAA Bateriaes x2
- User Manual x1
- Iron Pipes x12
- Shade x1
- Metal Rings x2

## Specification

MODEL	MF18566
<b>Lamp</b>	
Material	Metal + Fabric + PC
POWER	MAX 60W
Input Voltage	AC120V 60HZ
Size	23"(Length between two legs)x12.2" (D)x58.26"(H)
<b>Bulb</b>	
Power	8W
LUMINOUS FLUX	1000LM
DIMMABLE	5%-100%
Color Temperature	3000K-6000K
Battery for Control	AAAx2
Remote Distance	MAX49. 2ft
Input Voltage	AC120V 60HZ

## Product Structure

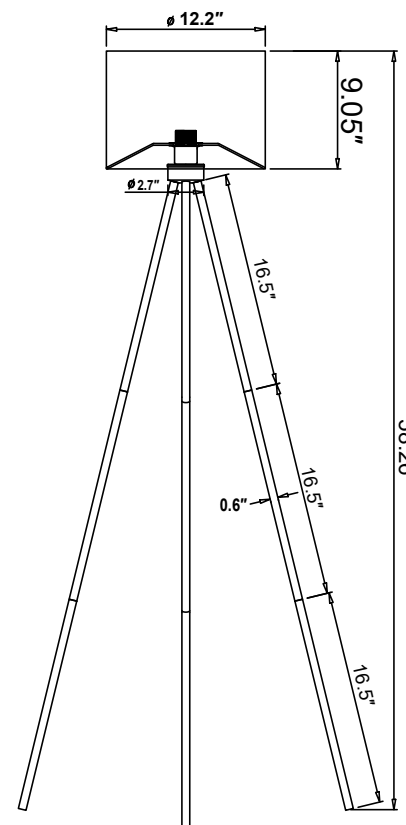

## InstallationMap

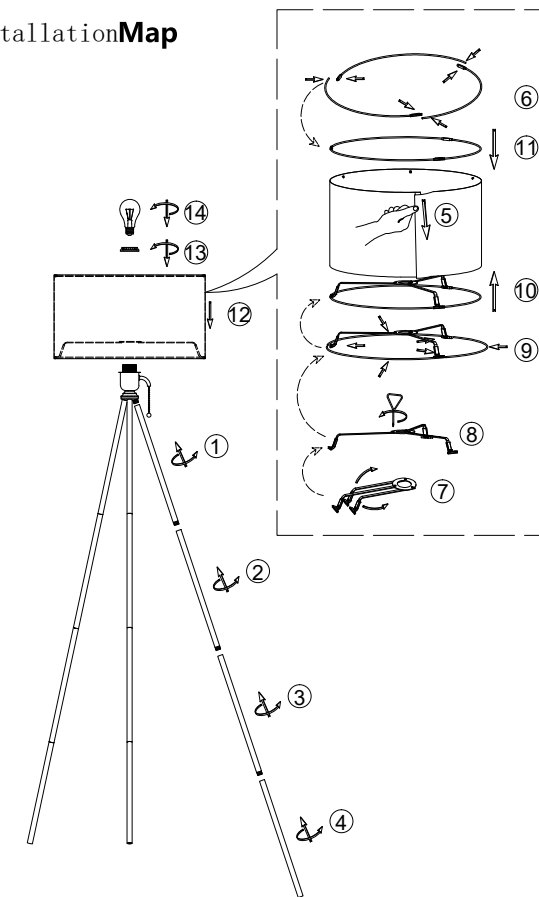

Step 1 - 4: Screw all the together side by side according to installation map, Finish the other two legs and go the next step

Step 5: Tape the Velcro of the lamp shade, make it a circle

step6- 11 install the iron frames according to the installation map

Step 12: Put the lamp shade through the lamp base

Step 13: Screw the lamp ring to the bulb base through the bottom of the shade(Unscrew the lamp ring from the base firstly)

Step 14: Screw the E26 based bulb to the lamp base

## Usage

There are two ways to control : Pull chain control/Remote control

### Pull chain ON/ OFF



## Function of Remote Control

- Ⓜ Set a 1h timer ( Lamp Light get several flickers mean sthe 1h timer is set successful)
- Ⓜ Short press to tum on/off light.
- Ⓜ Short/Long press to enhance the CCT ( 3000K to 6000K ) as you like.
- Ⓜ Short/Long press to lower the CCT ( 6000K to 3000K ) as you like.
- Ⓜ Short press to be the max brightness and CCT immediately.
- Ⓜ Short/Long press to enhance the brightness as you like.
- Ⓜ Short/Long press to lower the brightness as you like.
- Ⓜ Short press to Adjust Color Temperature 4 Levels.
- Ⓜ Short press to enter reading mode.
- Ⓜ Short press to enter breastfeed mode.
- Ⓜ Short press to enter night mode.
- Ⓜ Short press to enter work mode.

## When can you use the remote control?

A 8w 1000Lumens intelligent bulb is included in the package. You may use regular bulb to replace the intelligent bulb if you prefer that. Please note that regular bulb cannot match the remote control. Need to repair the remote control and bulb if you replace one of them. Please check the repair method below.

Pull chain switch is the prerequisite for remote control. Make sure you have turned on the lamp with the pull chain switch when you using the remote for turning on/off, changing the CCT, modes and timer. Remote control cannot be used if pull chain switch is turning off status.

## How to repair the remote control and the bulb if the remote is not working?

Long press the 'Ⓜ' button on the remote control and turn on the lighting by pull chain switch at the same time. When you see the bulb flashes, it means the matching process is completed and you can use the remote now.

Please contact us by Email: pazzo.service@gmail.com if the remote still doesn't work after this.

## How to clear pairing information if you want to change a remote?

Plug in the power and make sure the bulb on. Press on/off bottom on the remote for 5 times(press on then off as one time ). It means you have cleared the previous pair information successfully when the bulb flashes for several times after this. Then turn off the lighting by pull chain switch. Please repeat this step if the bulb doesn't flash.

You can repair the remote after this if necessary.

## Product Care

- Please do not bend violently the lamp head to avoid damage when adjusting the angle of the lamp.
- Please read the user manual before use.
- Indoor use only. It is non waterproof .Do not use this product in humid environments or at high temperatures.
- Cut off the power when cleaning it or not using it.
- Do not use it exceed the voltage , the proper voltage for US is AC110- 120V.60Hz.
- Stop using immediately if there is any defective issues found in the product.

## WARRANTY POLICIES

- Our tripod floor lamp is backed by 12 Months product quality reason warranty.
- The postage for the return or replacement of goods without quality problems should be paid by users and the postage for the re-delivery should be covered by the seller. Relevant invoices and free gifts, if having, should be sent back together. For questions ,assistance , or support , please contact the Customer Service by e-mail with your order number and product model number( E-mail: pazzo.service@gmail.com). We will send you future information about the return or the exchange.

## NON-WARRANTY PROVISIONS

- 1.Unauthorized repair, misuse, collision, negligence, abuse, accident, alteration, or tear-up or alteration of label or false-proof mark;
2. Alteration, replacement or tear-up of the product's original serial number label and other similar phenomena;
3. No product serial number, nonconformity between the product mode and serial number on the warranty voucher and the real product;
4. Expiration of the product warranty;
5. Product appearance damages due to abnormal usage;
6. Outer package and the attached free gifts, out-of-scope service or additional configurations or free gifts promised or provided by sales personnel;
7. Improper storage, for instance, functional damages caused by long-term exposure to abnormal humidity or temperature;
8. Damages caused by failure to follow the operating instructions, man-made abuse or misuse, unauthorized modification, force majeure.

