

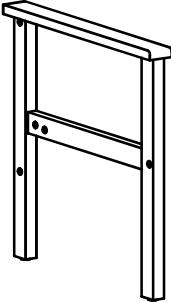

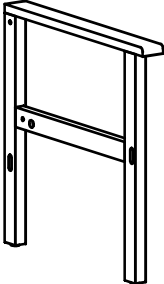
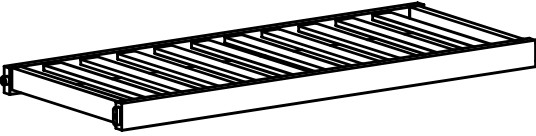

# Assembly Instructions

Please read this before you proceed

NUMBER	COMPONENT	QUANTITY
A	 Right leg	1pc
B	 Left leg	1pc
G	 Bench seat	1pc
H	 Bench connecting bar	1pc
K	 Bench back	1pc
L	 Single cushion seat	1pc

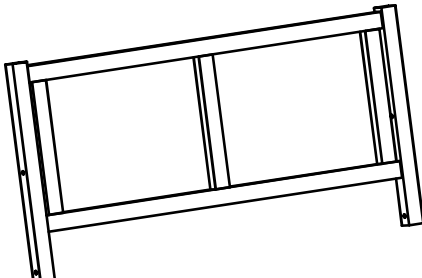
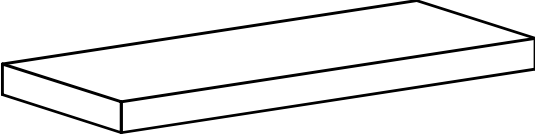
# Assembly Instructions

Please read this before you proceed

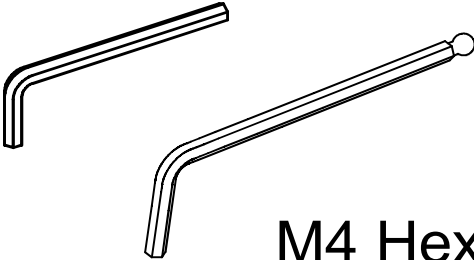
NUMBER	COMPONENT	QUANTITY
P	 Screw M7x60mm	8pcs
Q	 Screw M7x50mm	2pcs
V	 M4 Hex wrench	2pcs

# Assembly Instructions

Please read this before you proceed

①

A x 1
B x 1
G x 1
H x 1
P x 6
V x 1

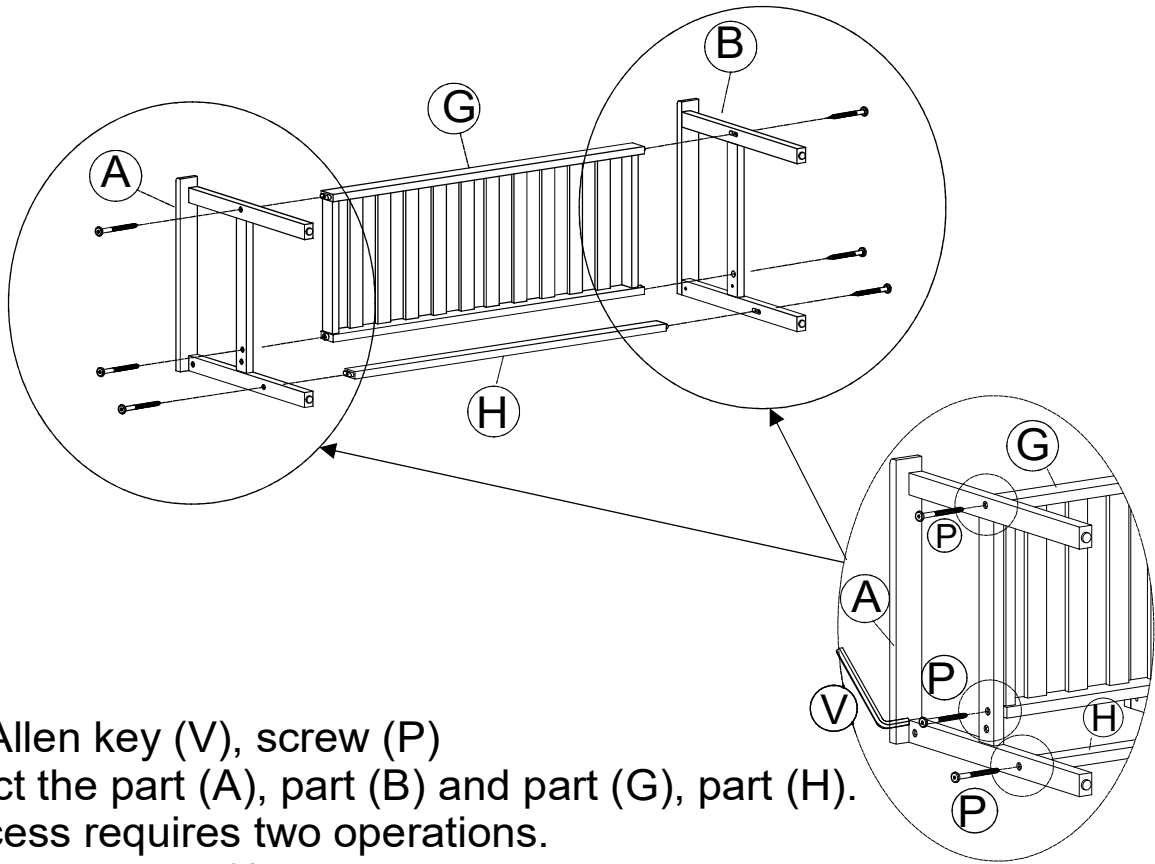

Use the Allen key (V), screw (P) to connect the part (A), part (B) and part (G), part (H). This process requires two operations.  
Note: only tighten 80%

②

K x 1
P x 2
Q x 2
V x 1

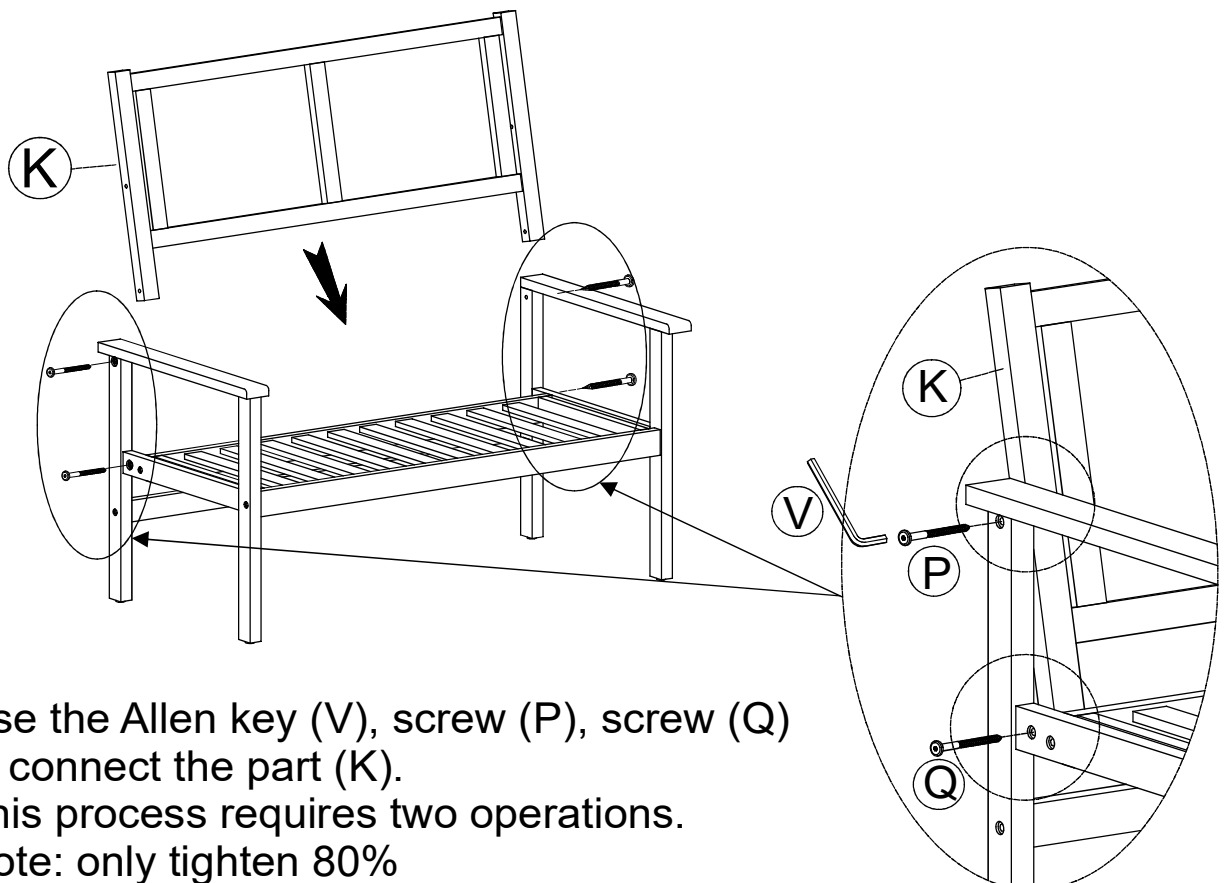

Use the Allen key (V), screw (P), screw (Q) to connect the part (K). This process requires two operations.  
Note: only tighten 80%

# Assembly Instructions

③

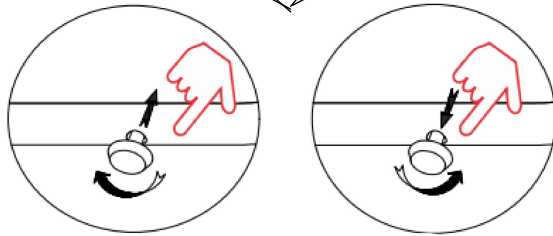
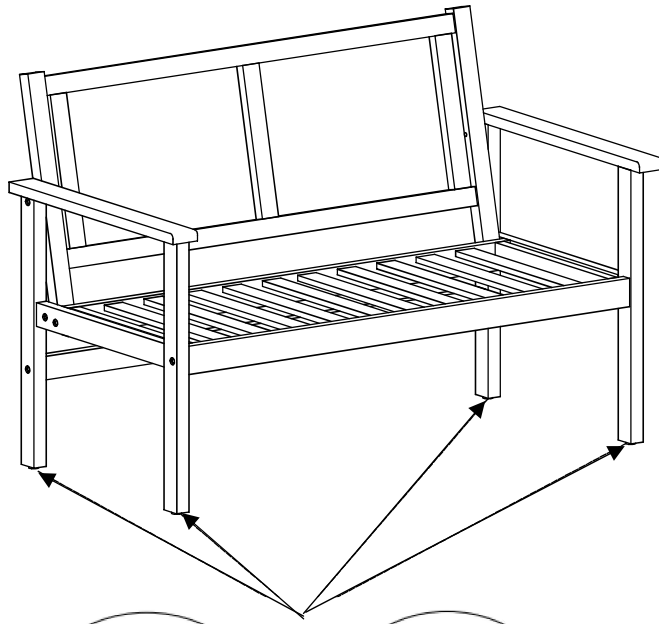

Adjust this position up or down

④

Lx 1

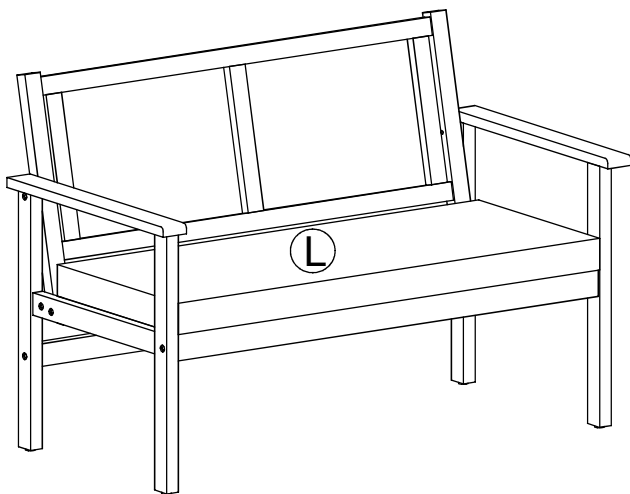

Use part (L).

⑤

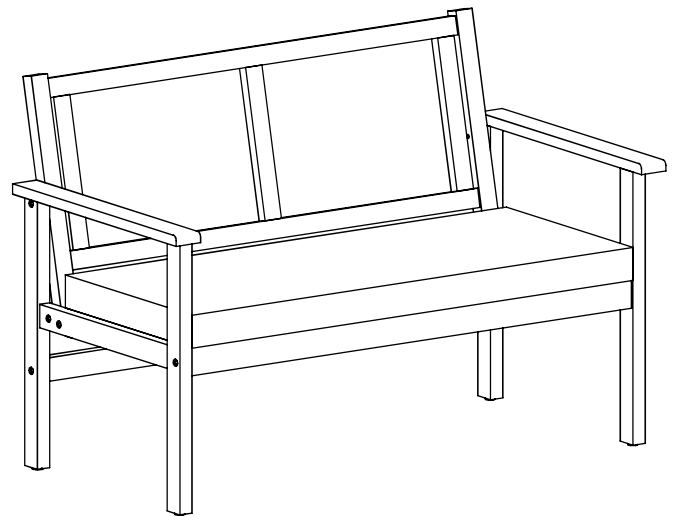

Finish