

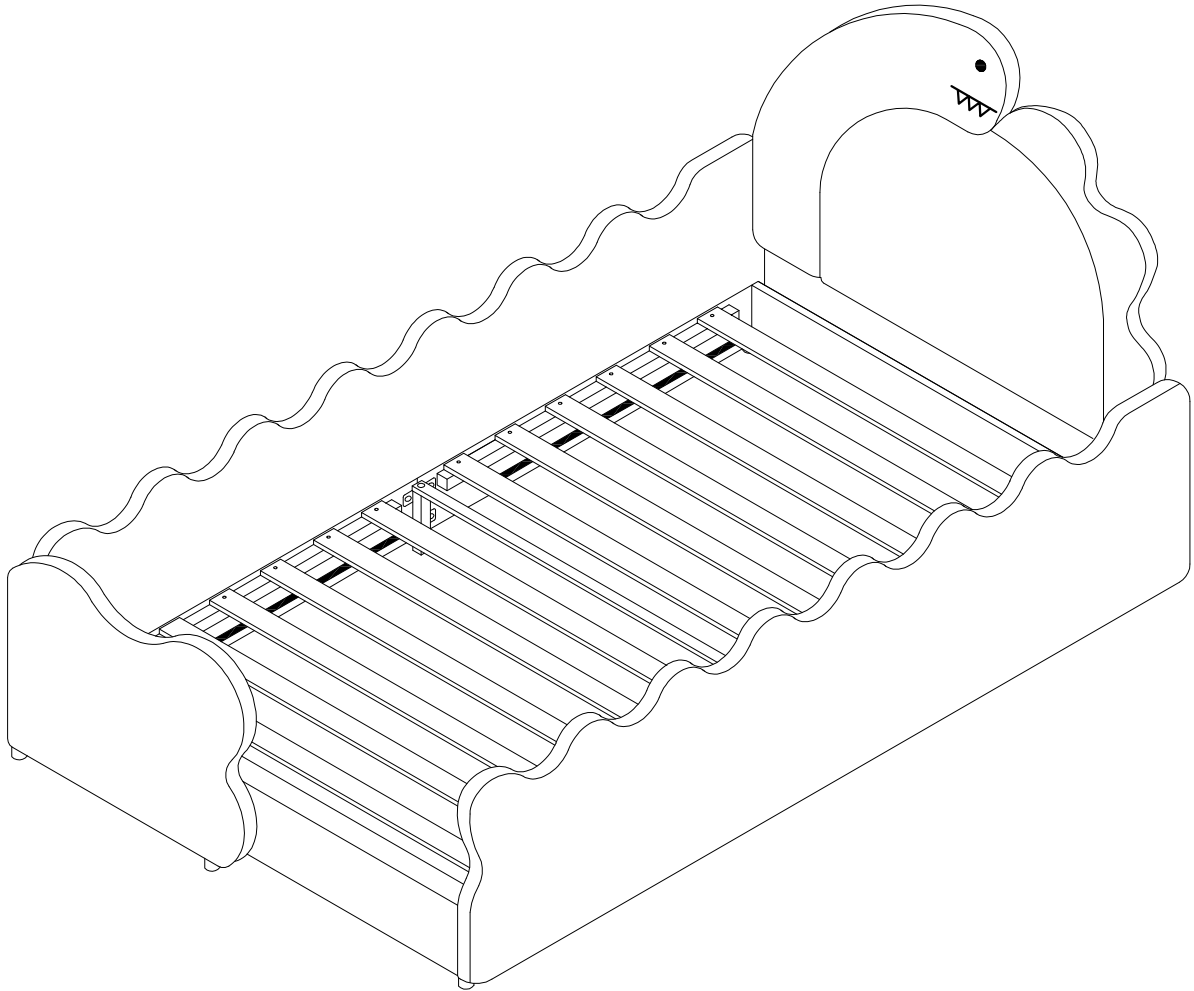

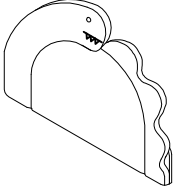

ASSEMBLY INSTRUCTION

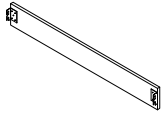

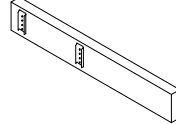
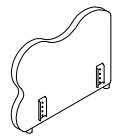
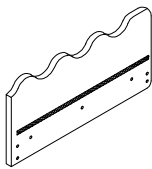
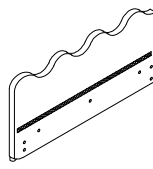
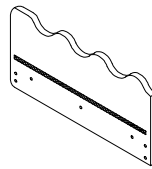
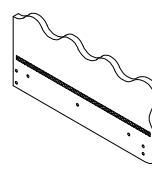
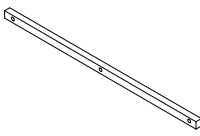

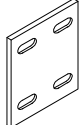

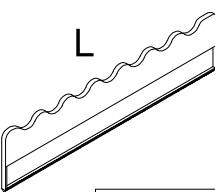
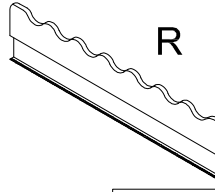
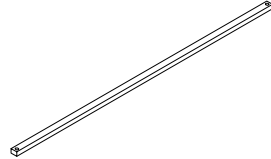
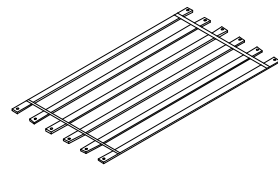
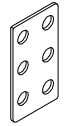
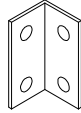
266T

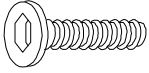
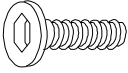

PARTS LIST

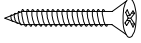
<p>① Headboard</p>  <p style="text-align: center; border: 1px solid black; padding: 2px;">1PC</p>	<p>② HB crossboard</p>  <p style="text-align: center; border: 1px solid black; padding: 2px;">1PC</p>	<p>③ Footboard</p>  <p style="text-align: center; border: 1px solid black; padding: 2px;">1PC</p>	<p>④ FB Side Rail</p>  <p style="text-align: center; border: 1px solid black; padding: 2px;">1PC</p>
<p>⑤ HB Side Rail -L</p>  <p style="text-align: center; border: 1px solid black; padding: 2px;">1PC</p>	<p>⑥ FB Side Rail -L</p>  <p style="text-align: center; border: 1px solid black; padding: 2px;">1PC</p>	<p>⑦ HB Side Rail -R</p>  <p style="text-align: center; border: 1px solid black; padding: 2px;">1PC</p>	<p>⑧ FB Side Rail -R</p>  <p style="text-align: center; border: 1px solid black; padding: 2px;">1PC</p>
<p>⑨ Side rail support</p>  <p style="text-align: center; border: 1px solid black; padding: 2px;">4PCS</p>	<p>⑩ Side rail feet</p>  <p style="text-align: center; border: 1px solid black; padding: 2px;">2PCS</p>	<p>⑪ Iron Plate</p>  <p style="text-align: center; border: 1px solid black; padding: 2px;">4PCS</p>	<p>⑫ Bed Leg</p>  <p style="text-align: center; border: 1px solid black; padding: 2px;">8PCS</p>
<p>⑬ Side-rail jacket L</p>  <p style="text-align: center; border: 1px solid black; padding: 2px;">1PC</p>	<p>⑭ Side-rail jacket R</p>  <p style="text-align: center; border: 1px solid black; padding: 2px;">1PC</p>	<p>⑮ Center cross bar</p>  <p style="text-align: center; border: 1px solid black; padding: 2px;">1PC</p>	<p>⑯ Slat</p>  <p style="text-align: center; border: 1px solid black; padding: 2px;">2SET</p>
<p>⑰ HB -Iron Plate</p>  <p style="text-align: center; border: 1px solid black; padding: 2px;">2PCS</p>	<p>⑱ FB-connect plate</p>  <p style="text-align: center; border: 1px solid black; padding: 2px;">2PCS</p>		

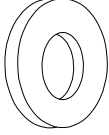
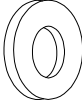
HARDWARE LIST

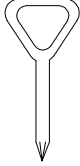
<p>A Screw</p>  <p>m8*30mm 44PCS</p>	<p>B Screw</p>  <p>m8*20mm 6PCS</p>	<p>C Screw</p>  <p>m6*45mm 12PCS</p>	<p>D Screw</p>  <p>M4*30mm 24PCS</p>
<p>E Lock Washer</p>  <p>m8*13mm 50PCS</p>	<p>F Flat Washer</p>  <p>m8**19mm 50PCS</p>	<p>G Flat Washer</p>  <p>m6*16mm 12PCS</p>	<p>H Inner allen wrench</p>  <p>M8 1PC</p>
<p>I Inner allen wrench</p>  <p>M6 1PC</p>	<p>J Screwdriver</p>  <p>1PC</p>		

Assembly Steps



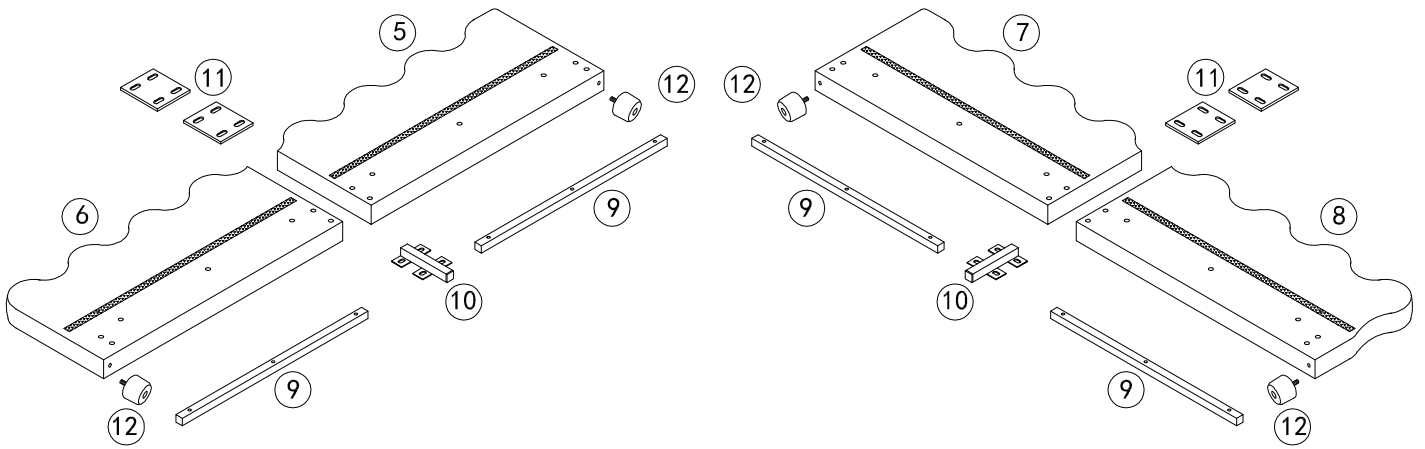

STEP 1:

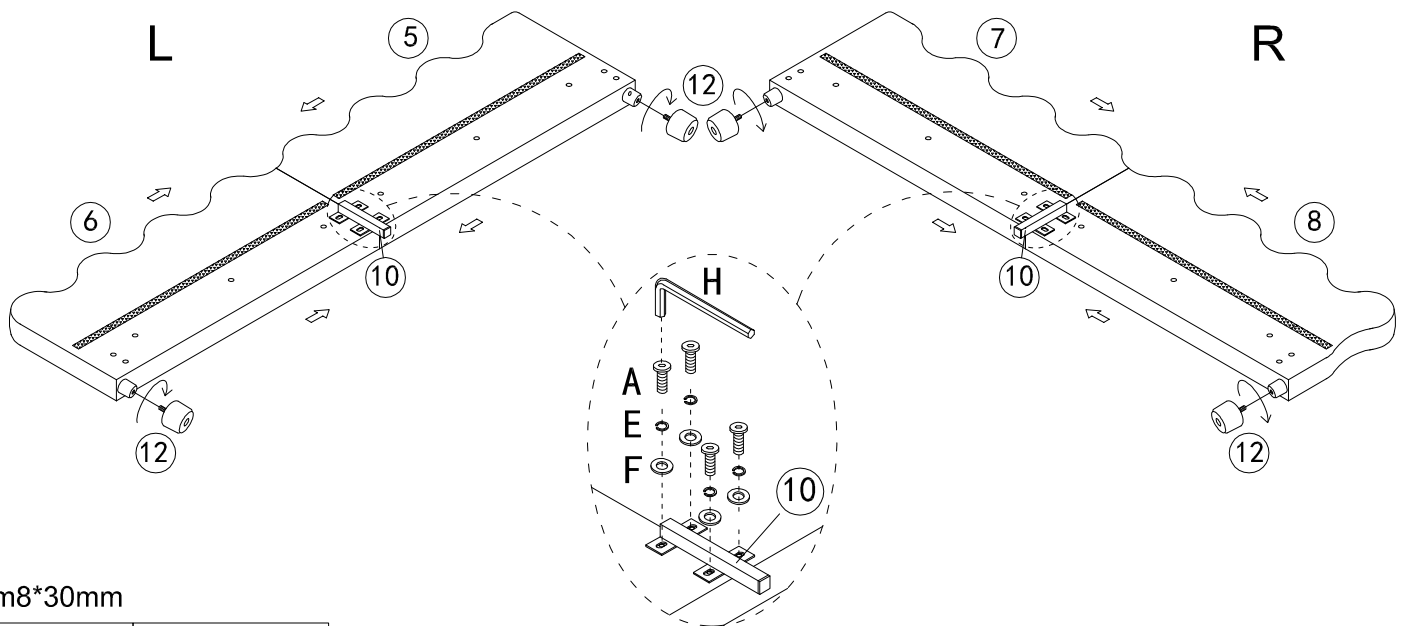

STEP 2:



m8*30mm

	A x 8PCS
	H x 1PC
	E x 8PCS
	F x 8PCS

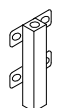
 10 x 2PCS



 12 x 4PCS

Assembly Steps

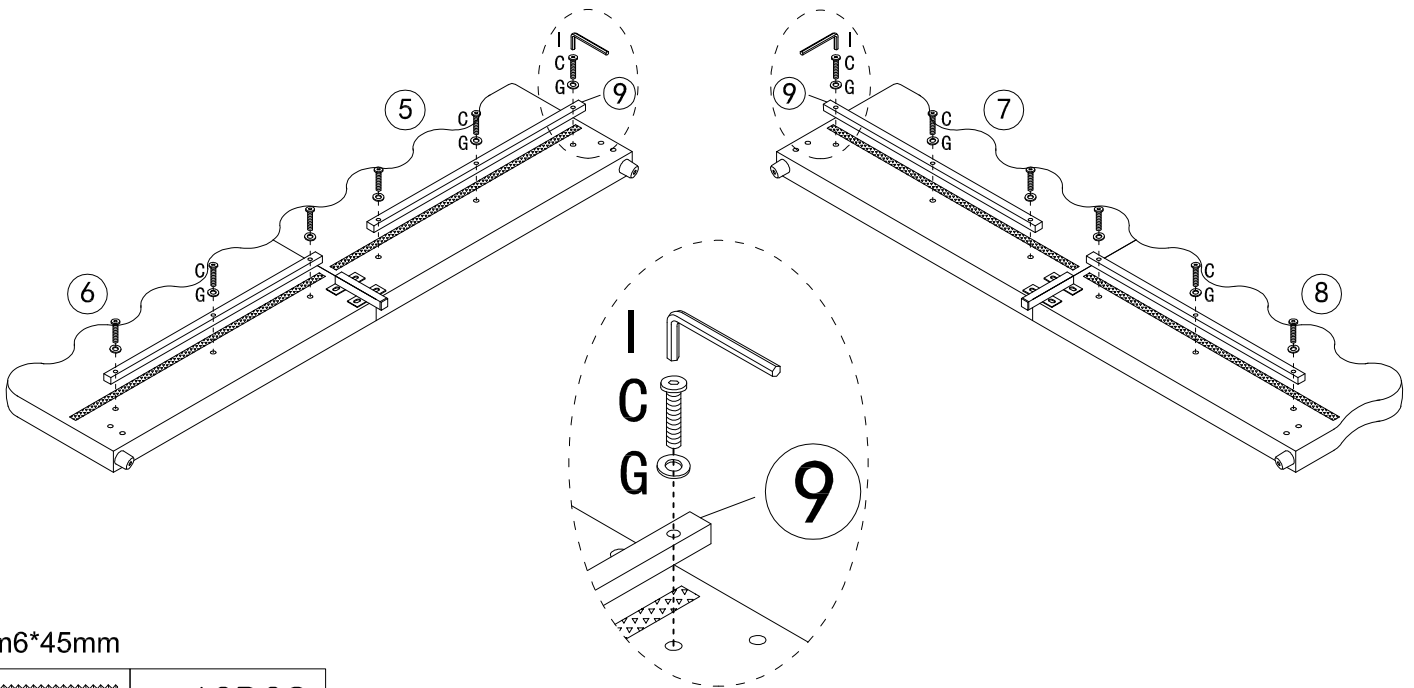
STEP 3:



m6*45mm



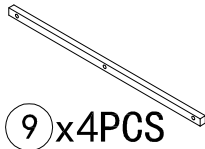

	C x12PCS
	I x 1PC
	G x12PCS

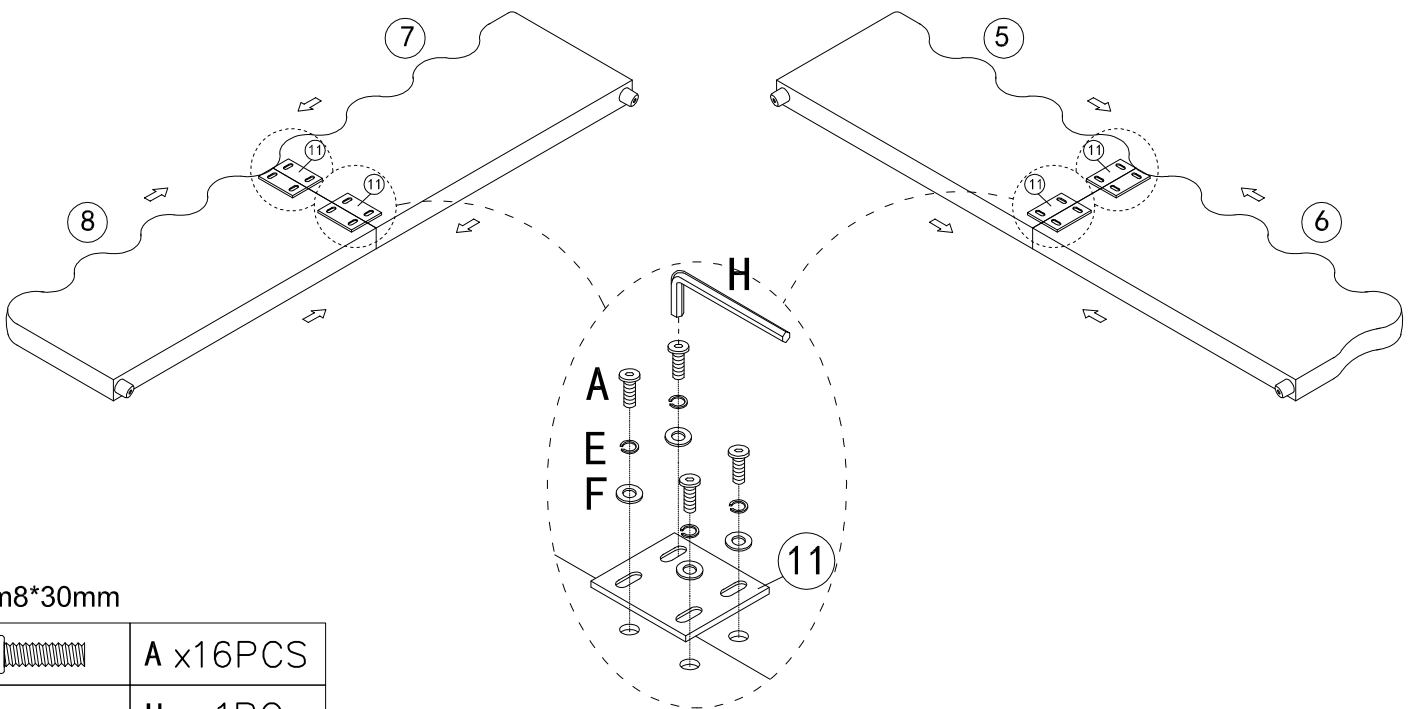

STEP 4:



m8*30mm

	A x16PCS
	H x 1PC
	E x16PCS
	F x16PCS

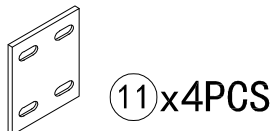

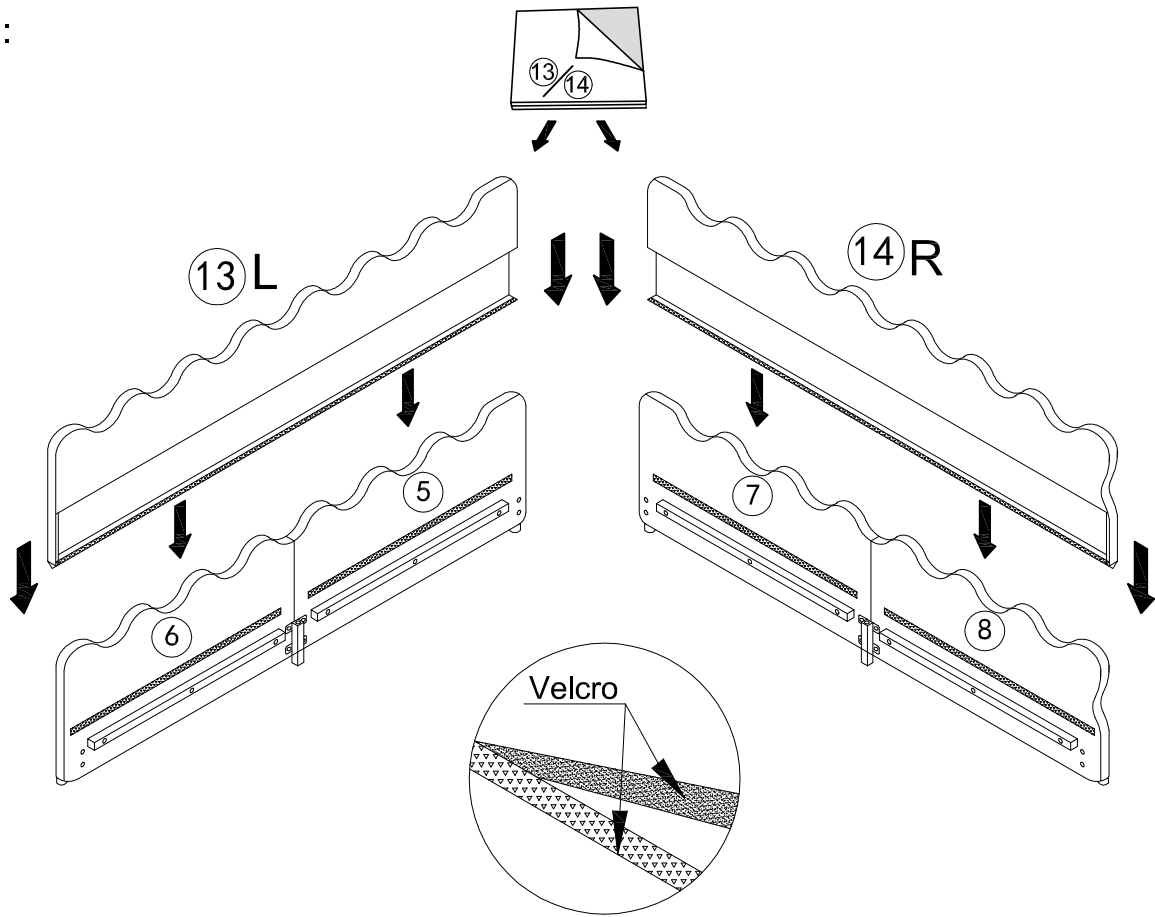

Assembly Steps

STEP 5:

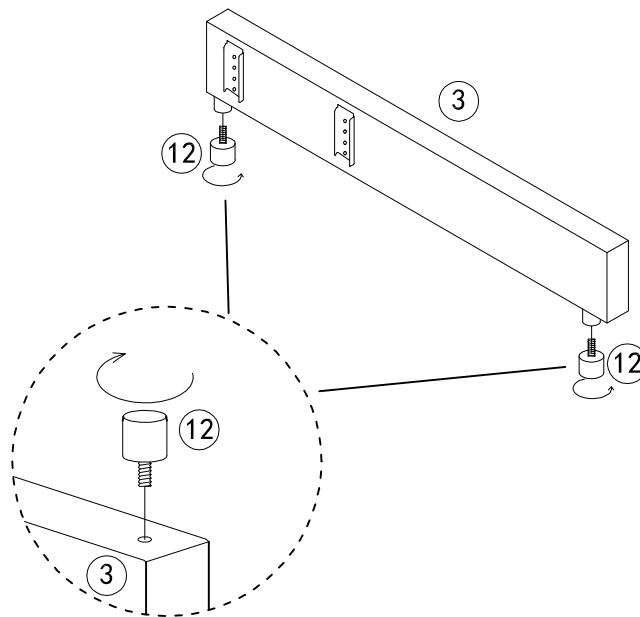

STEP 6:





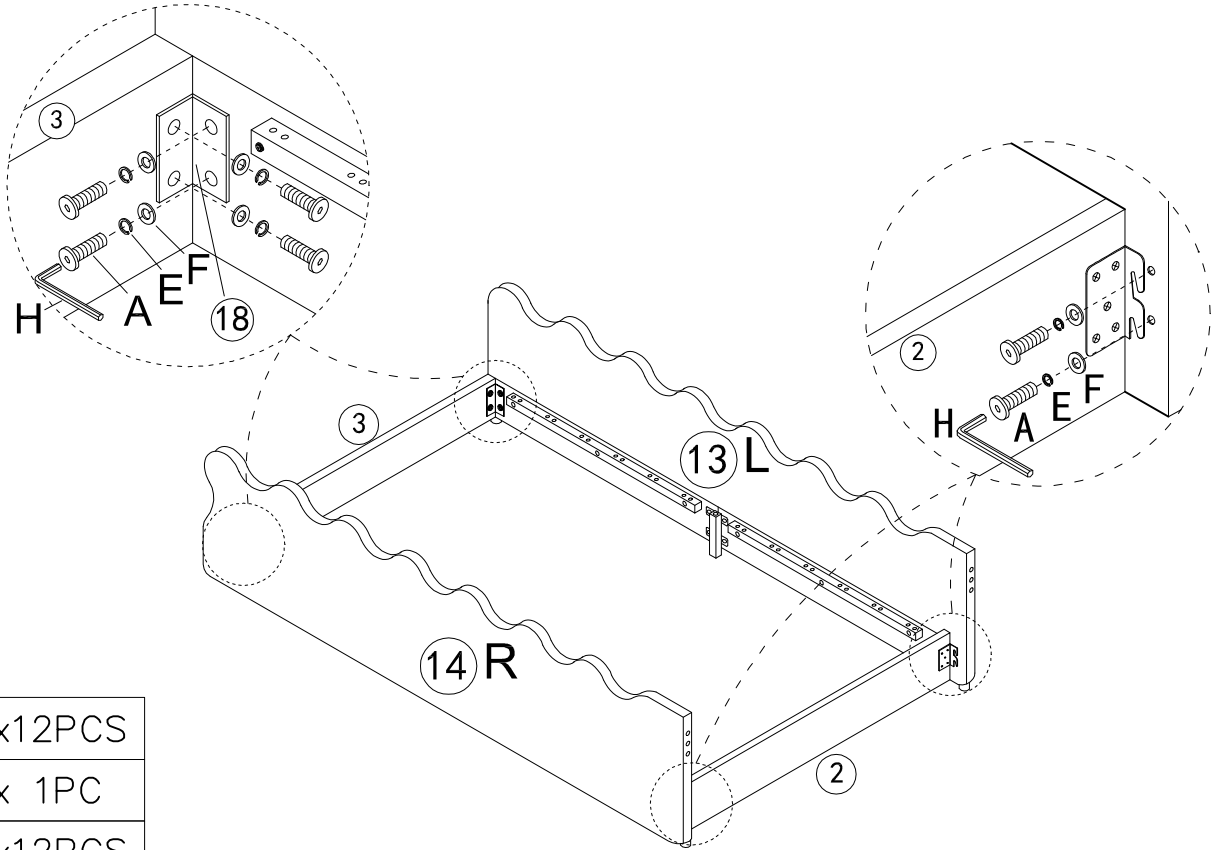

 12)x2PCS

Assembly Steps

STEP 7:





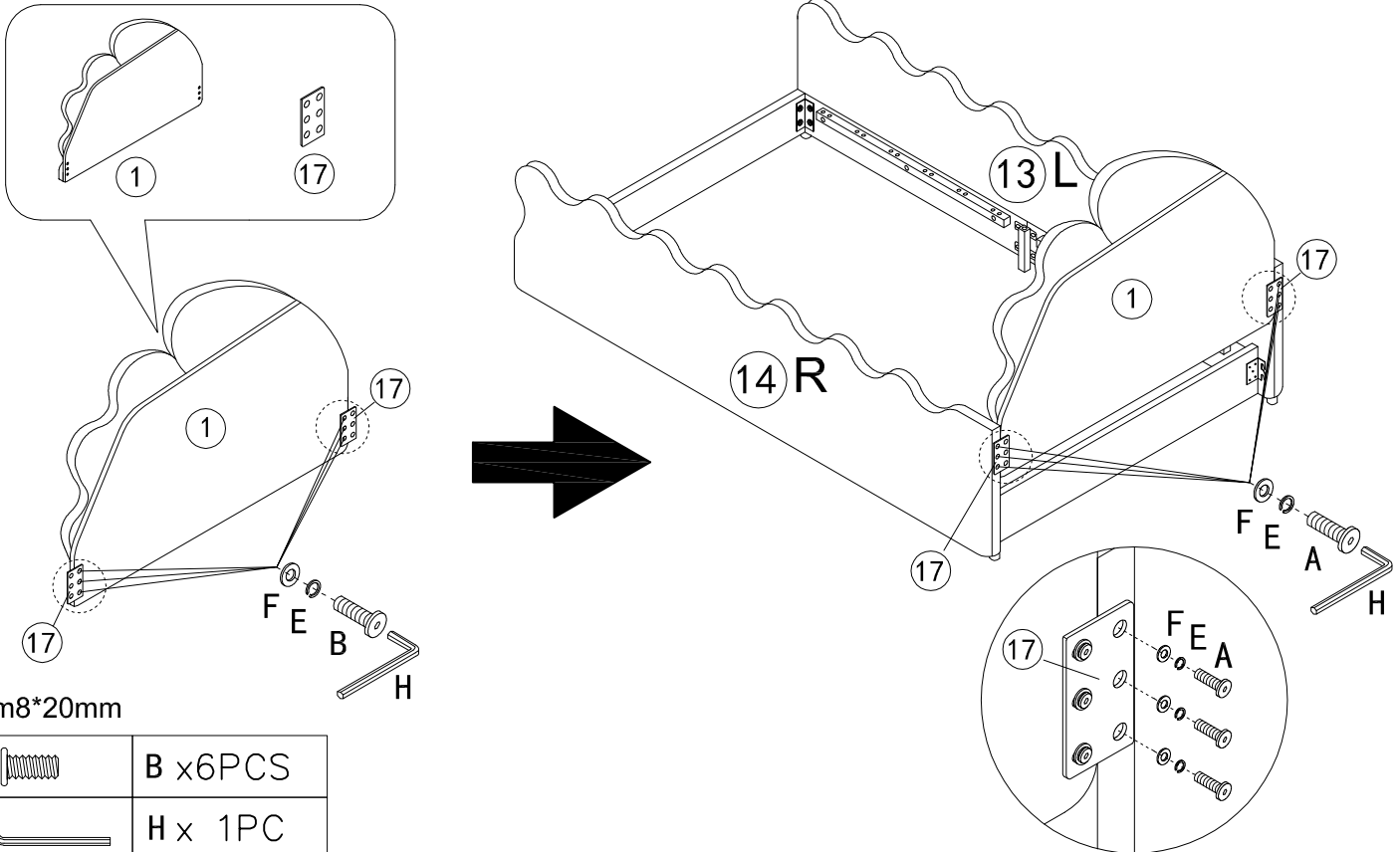

m8*30mm

	A x12PCS
	H x 1PC
	E x12PCS
	F x12PCS

STEP 8:







m8*20mm

	B x6PCS	
	H x 1PC	
	E x12PCS	m8*30mm
	F x12PCS	 A x6PCS

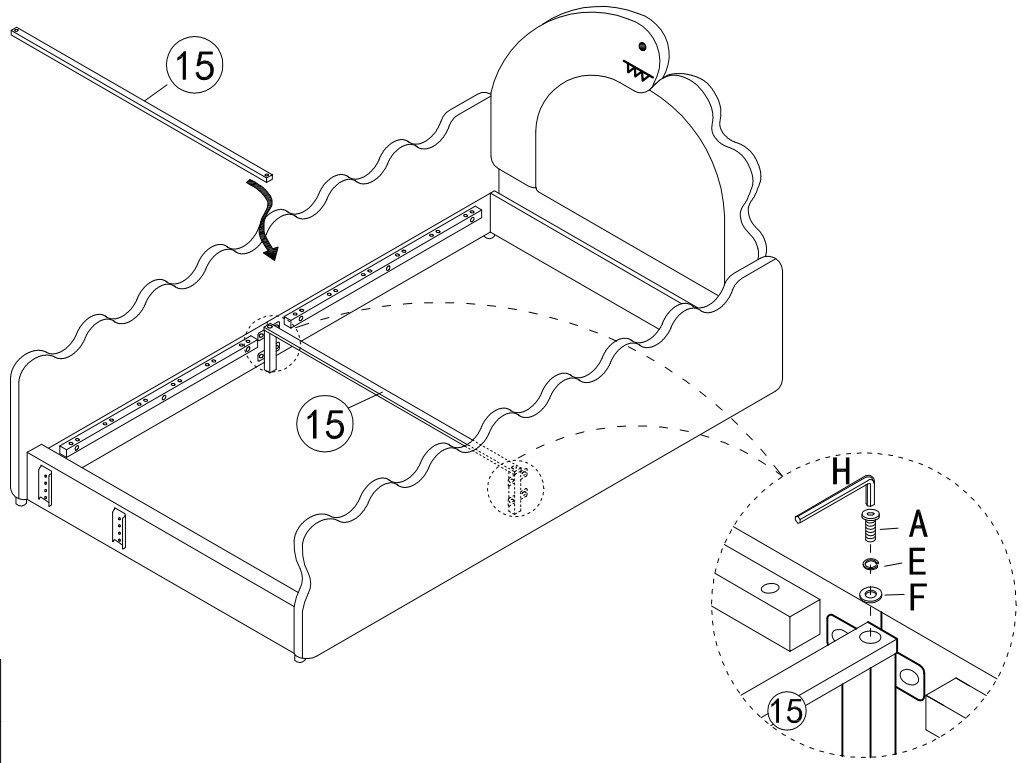
Assembly Steps

STEP 9:



	A x2PCS
	H x 1PC
	E x2PCS
	F x2PCS

STEP 10:

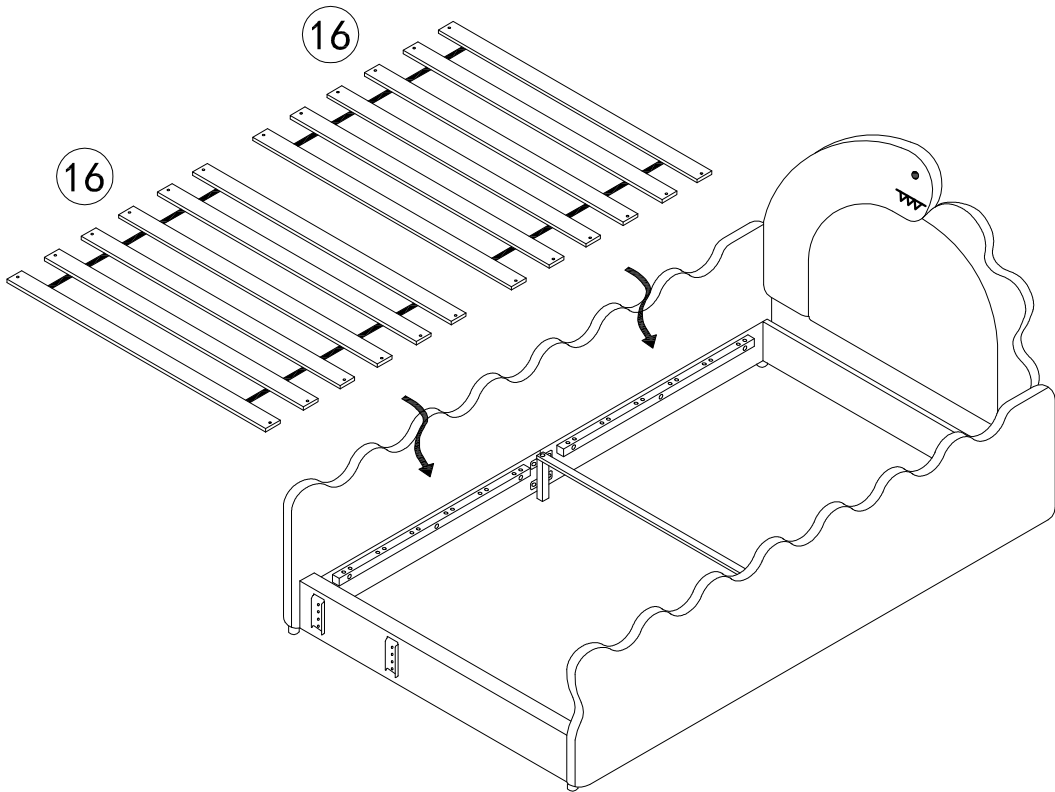

Assembly Steps

STEP 11:

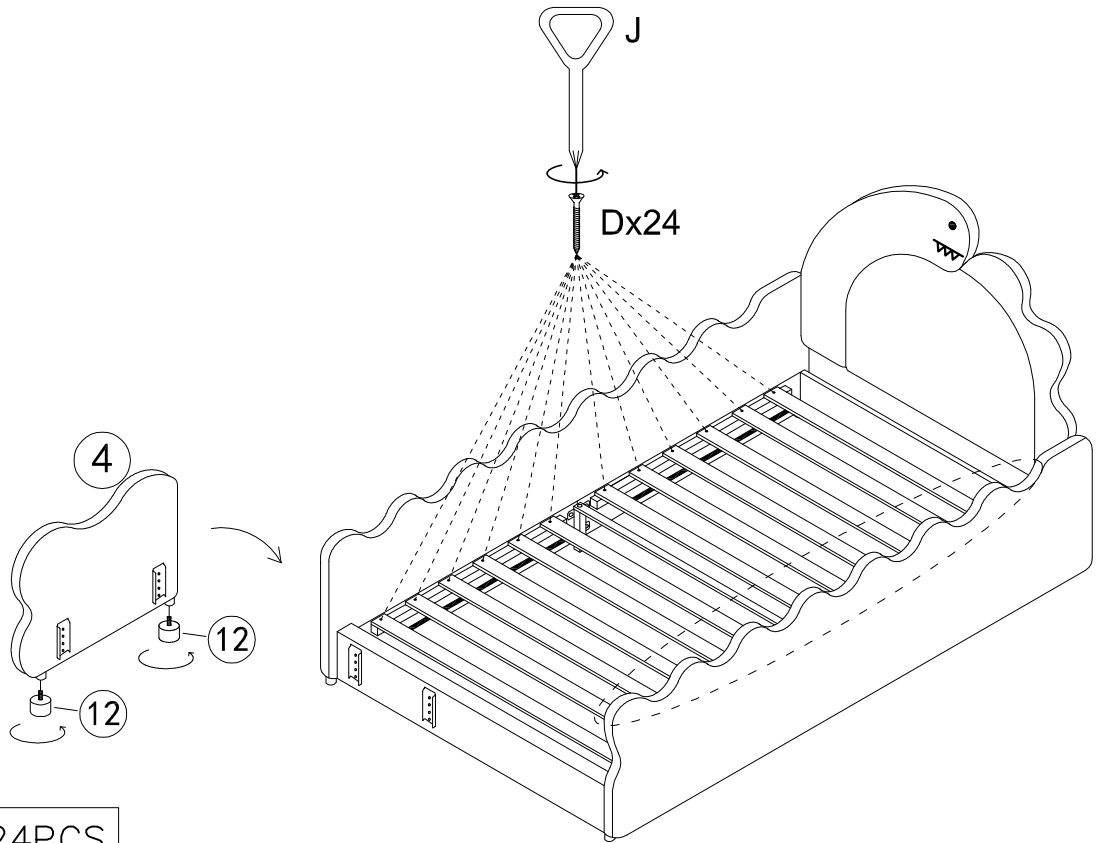

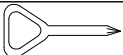
	D x24PCS
	J x1PC

 12x2PCS

STEP 12:

