

# Assembly Instructions

**Caution: You must read this before you proceed**

**Please look in the swivel plate pack for hardware packs**

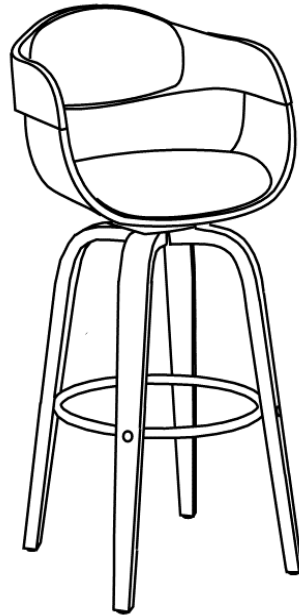





## Barstool



## Parts List

Label	Picture	Description	QTY
A	A line drawing of the chair seat, showing its curved shape and backrest.	Chair Seat	1
B	A line drawing of a single leg, showing its curved top and straight bottom.	Leg	4
C	A line drawing of the circular footrest, showing its outer and inner rings.	Footrest	1
D	A line drawing of the swivel plate, showing its circular shape and central hole.	Swivel Plate	1
E	A line drawing of a square metal plate with four small circles in a 2x2 grid.	Metal Plate	1

# Hardware

①		Bolts (M6*30 mm)	13
②		Bolts (M6*16 mm)	5
③		Spring Washer	5
④		Washer	5
⑤		Allen Key	1
⑥		Stopper	5

# Assembly Preparation

Before Beginning Assembly:

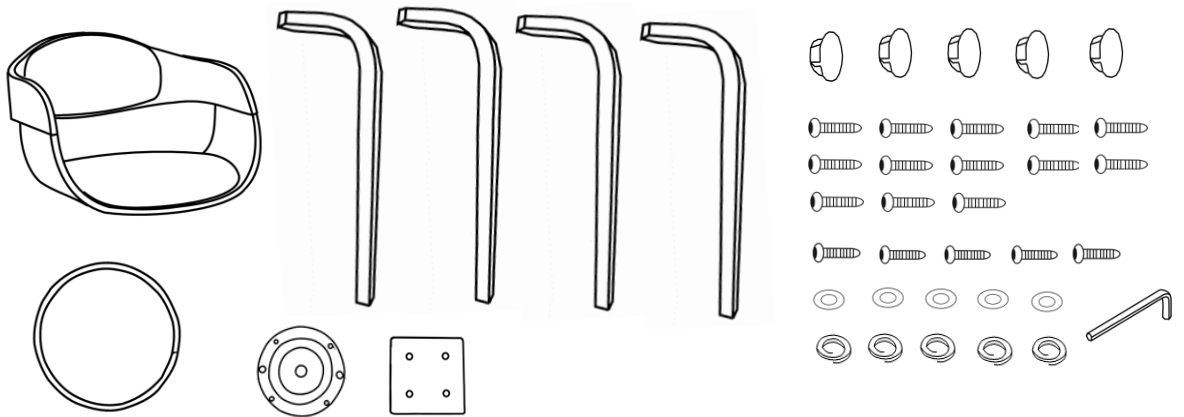

- Read instructions, cover to cover-



- Have 2 adults on hand for assembly-



- Do not assemble on flooring or carpet-



- Assemble on a clean non-marring surface (packing foam)-



- Save all packaging until finished-

# Assembly Steps

## Overview

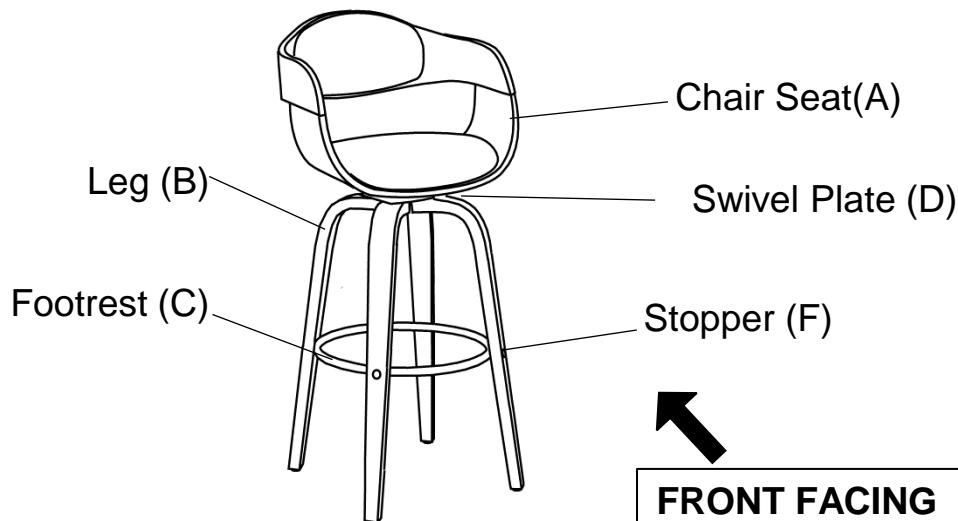

This Barstool has multiple parts and may require up to 30 minutes to assemble. To give you an overview of the Barstool parts, the above picture is to help you put the various parts into perspective. Please read through the instructions below to familiarise yourself with the parts and steps before assembly.

## Step 1

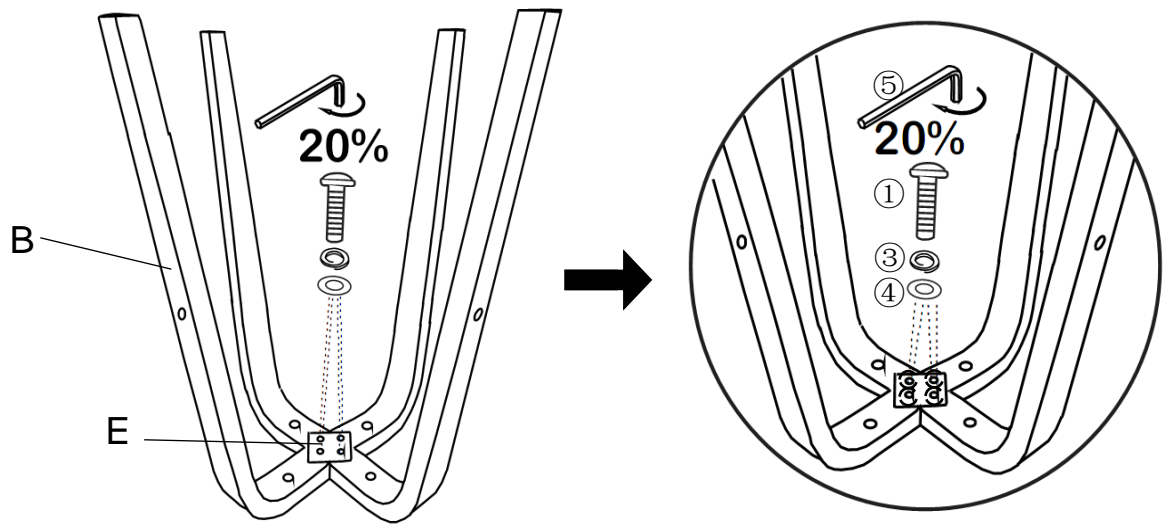

Unpack and place all parts on a clean, non-marring surface.

With assistance from a second adult, place the four Legs (B) downwards on a clean, non-marring table.

Attach the Metal Plate (E) to the four Legs (B) using the Bolts (①), Spring Washers (③) and Washers (④), with the Allen Key (⑤).

**Tighten 20% of the Bolts in a sequential manner.**

## Step 2

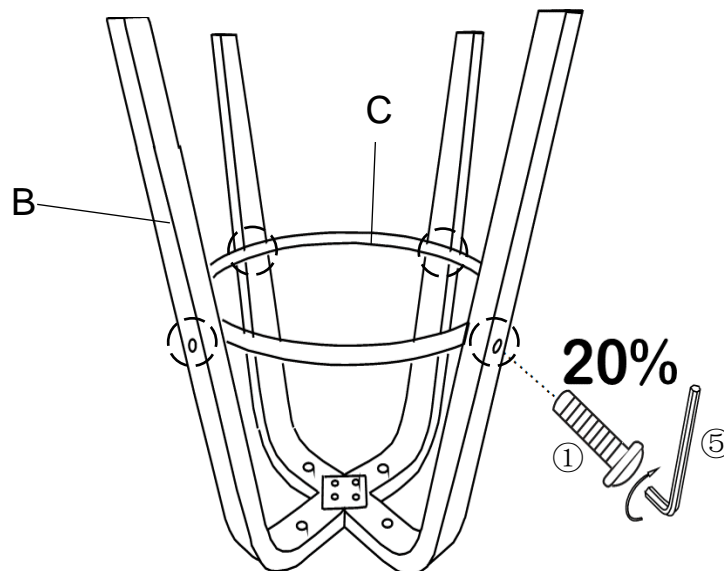

Attach the Footrest (C) to the Legs (B) using the Bolts (①) with the Allen Key (⑤) .

**Tighten 20% of the Bolts in a sequential manner.**

### Step 3

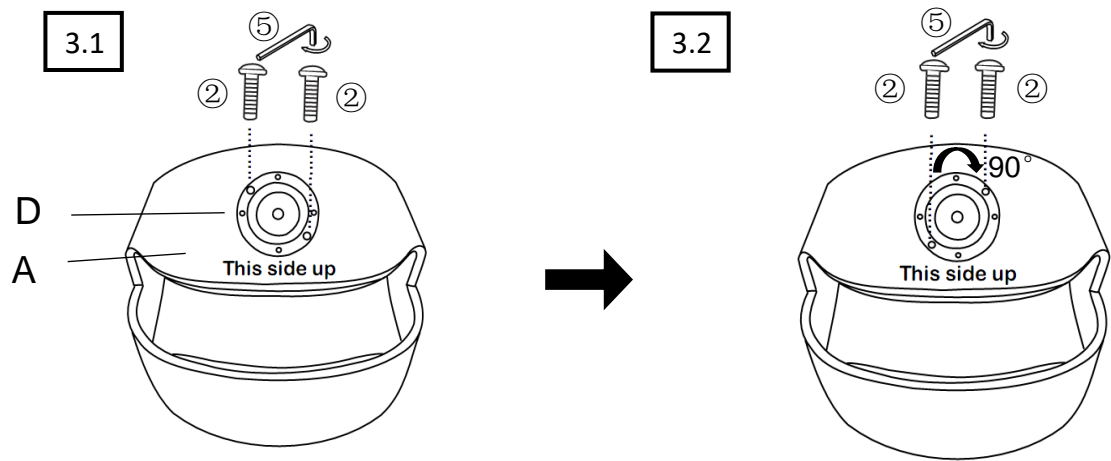

Place the bottom of the Chair Seat (A) on a clean, non-marring table.

3.1: Align the two larger holes on the upper Swivel Plate (D) and the two mounting positions on the bottom Swivel Plate (D) to the two mounting positions on the Chair Seat (A), attach the Swivel Plate (D) to the Chair Seat (A) using the Bolts (2), with the Allen Key (5).

3.2: Turn it 90 degrees, repeat the same as in step 3.1, and attach the other two mounting positions on the Swivel Plate (D) to the other two mounting positions on the Chair Seat (A) using the Bolts (2) with the Allen Key (5).

**Fully tighten the Bolts in a sequential manner. Make sure to use the upper side of the Swivel Plate (D) when attaching it to the Chair Seat (A).**

### Step 4

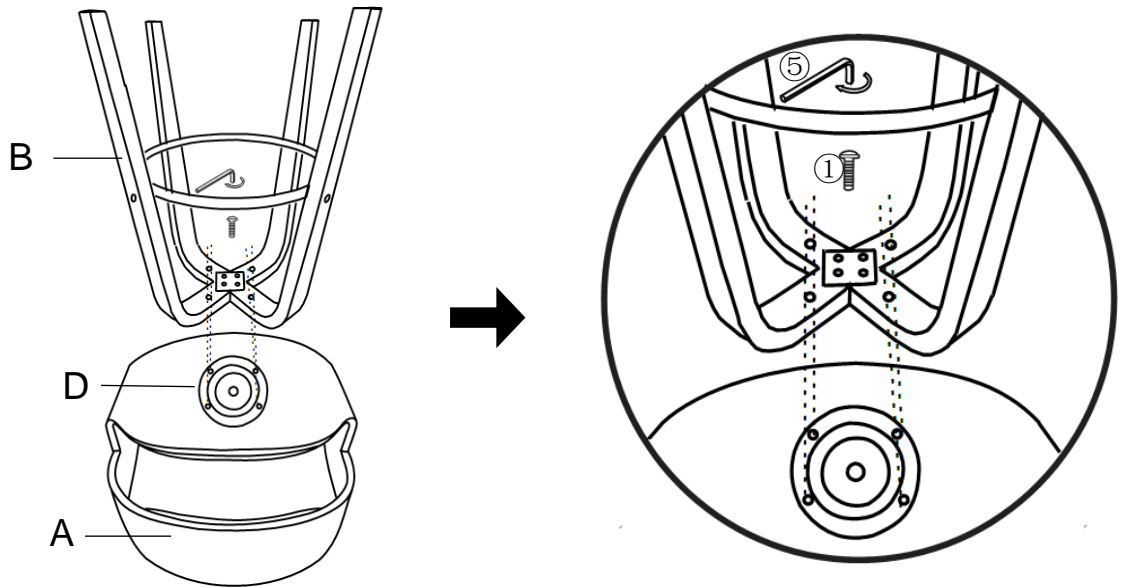

Attach the assembled Legs (B) into the Swivel Plate (D) as pictured, using the Bolts (1) with the Allen Key (5).

**Fully tighten all the Bolts in a sequential manner. Make sure all parts are connected and securely locked into position.**

## Step 5

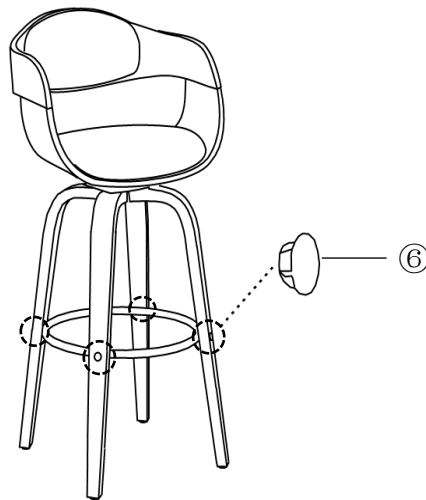

Turn the assembled Bar Chair right side up.  
Attach the Stopper (⑥) into the Leg (B) as pictured.

## Step 6

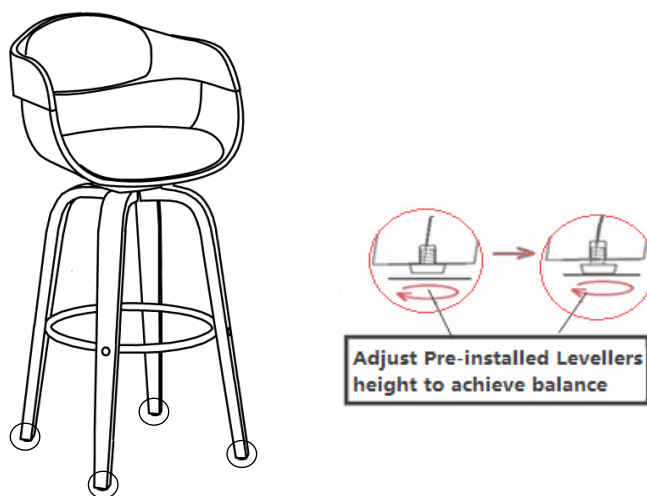











Check the stability and then tighten the remaining Bolts.  
DO NOT fully tighten a BOLT in one go and then move on to the next. Rather, In a sequential manner, gradually tighten each Bolt until all Bolts are evenly secured. This methodology will ensure maximum evenness once all Bolts are fully tightened. If the Barstool wobbles adjust the Pre-installed Levellers at the bottom of the Legs until the Barstool is level.

Your Barstool is ready for use.

**This Barstool can only be used on a flat, level surface.**

## Care & Maintenance

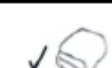
-  ● Furniture may scratch floors. We recommend using furniture pads to protect your floors.
  -  ● Do not put hot items directly on furniture surface.
  -  ● Do not clean furniture with harsh cleansers or polish.
  -  ● Do not place furniture under direct sunlight.
  -  ● Do not place furniture near heating or cooling vents.
  -  ● Do not write on furniture without a padded barrier to protect the surface.
  -  ● Do not place furniture outside . For indoor use only.
  -  ● Not for commercial use. For residential use only.
  -  ● Stains may be removed with mild soap solution and damp cloth.
  -  ● Children should not climb or jump on the furniture.
- 
-  ● Dust and pick-up spills using a clean, non-colored, lint-free cloth.