

# Assembly | Asambla | Assemblage

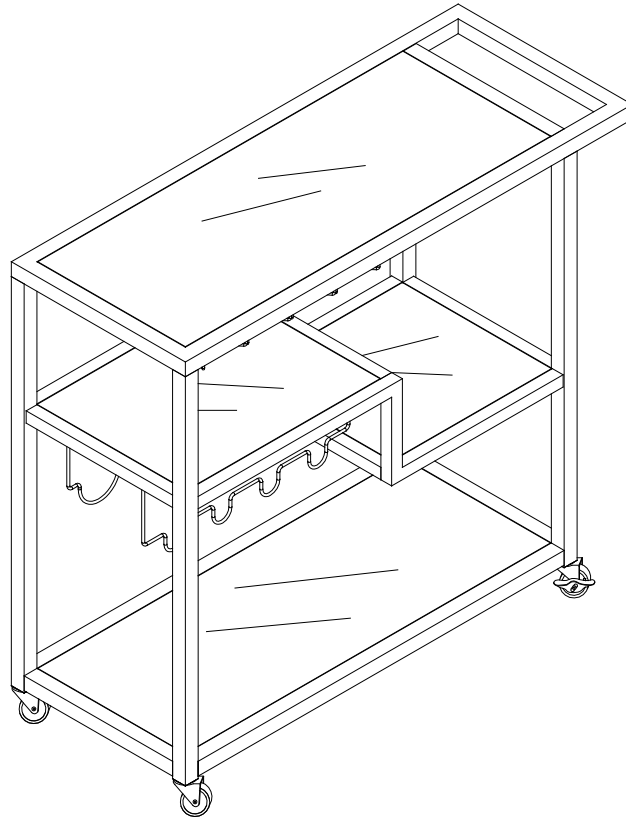

# Assembly | Asamblea | Assemblage

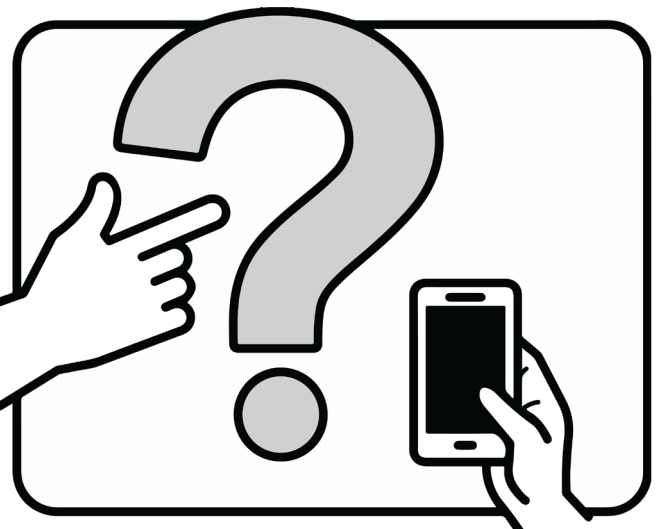
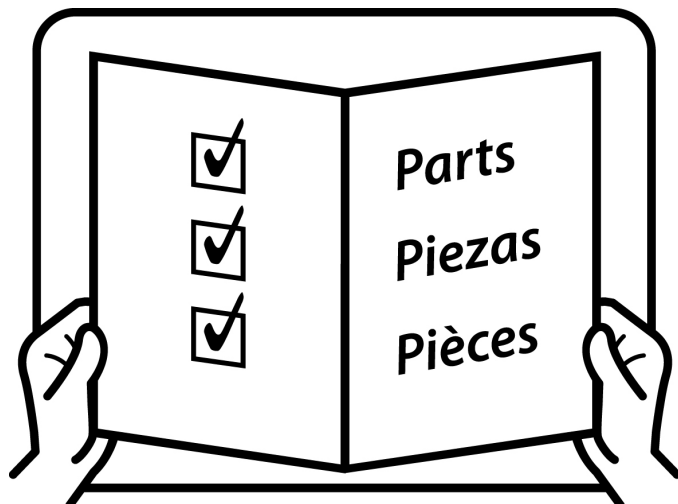
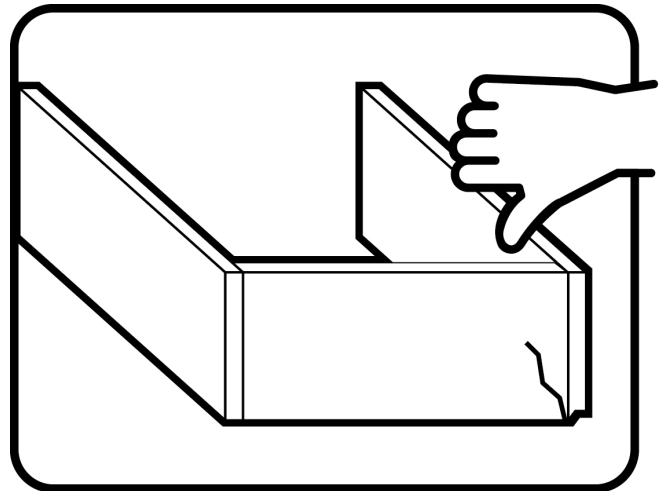
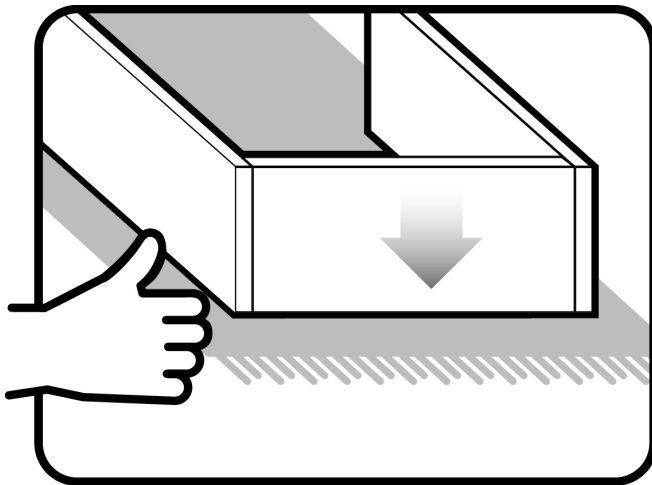
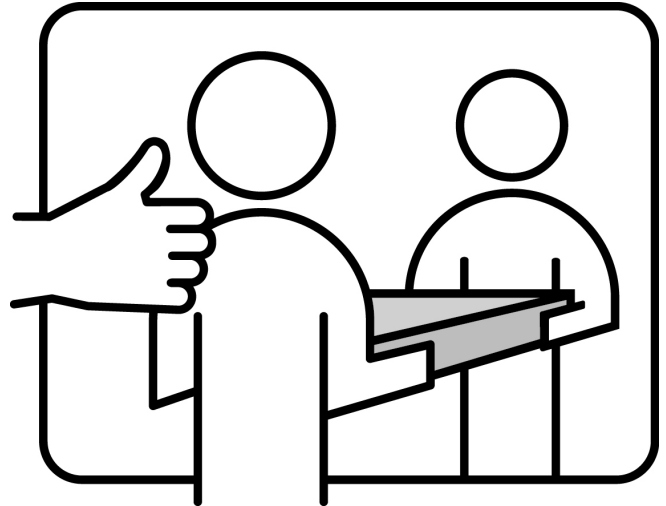
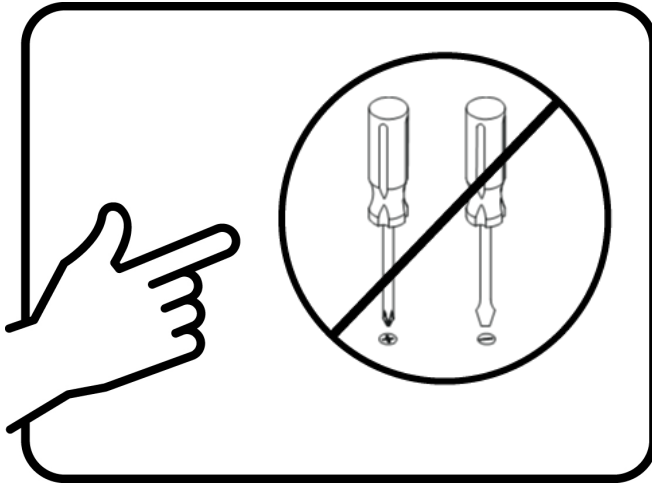

# Assembly | Asamblea | Assemblage

Techniques | Técnicas | Techniques

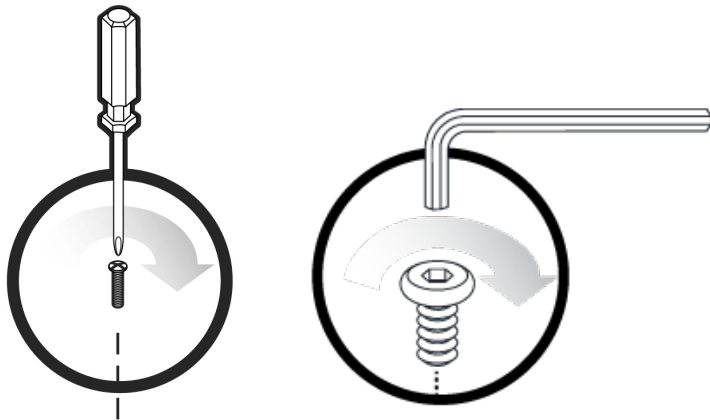

Care | Cuidado | Entretien





Safety | Seguridad | Sécurité





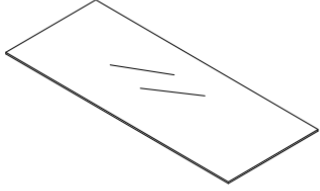
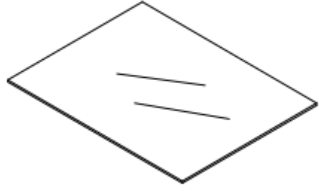
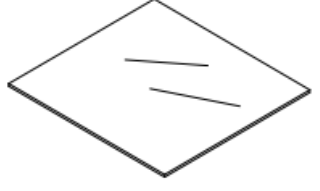
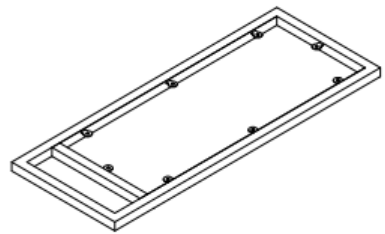
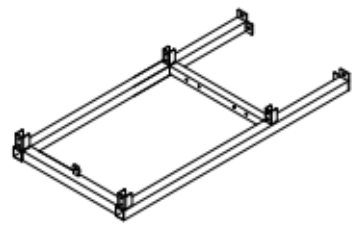
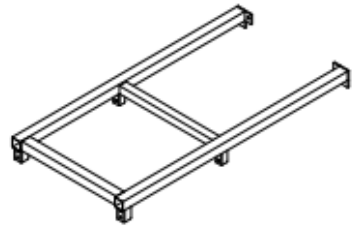

Note! | ¡Nota! | Remarque!

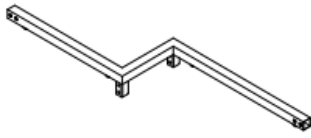
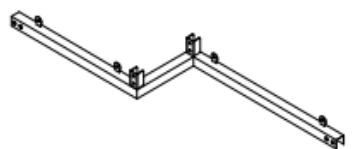





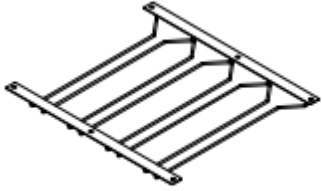

# Assembly | Asamblea | Assemblage

<p>A x2</p>  <p>Top and bottom glass shelf Estante de vidrio superior e inferior Étagère en verre supérieure et inférieure</p>	<p>B x1</p>  <p>Glass shelf Estante de vidrio Étagère en verre</p>	<p>C x1</p>  <p>Glass shelf Estante de vidrio Étagère en verre</p>
<p>D x1</p>  <p>Top frame Marco superior Cadre supérieur</p>	<p>E x1</p>  <p>Left side frame Marco lateral izquierdo Cadre latéral gauche</p>	<p>F x1</p>  <p>Right side frame Marco lateral derecho Cadre latéral droit</p>
<p>G x2</p>  <p>Lower rail Carril inferior Rail inférieur</p>	<p>H x1</p>  <p>Back rail Carril tresero Rail arrière</p>	<p>I x1</p>  <p>Front rail Carril delantero Rail avant</p>

# Assembly | Asamblea | Assemblage

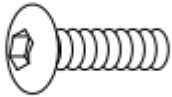
<p>J x1</p>  <p>Middle upper rail Carril medio superior Rail supérieur moyen</p>	<p>K x1</p>  <p>Middle lower rail Carril medio bajo Rail inférieur moyen</p>	<p>L x1</p>  <p>Wine glass Rack Estante de copas de vino Casier en verre à vin</p>
<p>M x1</p>  <p>Back wine rack Estante de vino tresero Casier à vin arrière</p>	<p>N x1</p>  <p>Front wine rack Estante de vino delantero Casier à vin avant</p>	

# Assembly | Asamblea | Assemblage

<p>1 x2</p>  <p>Brake castor Rueda de freno Ricin de frein</p>	<p>2 x2</p>  <p>Castor Cástor Castor</p>	<p>3 x46</p>  <p>Bolt Cerrojo Boulon <math>\varnothing 1/4" * 5/8"L</math></p>
<p>4 x24</p>  <p>Glass sucker Ventosa de vidrio Ventouse de verre</p>	<p>5 x1</p>  <p>Allen wrench Llave Allen Clé Allen</p>	<p>6 x1</p>  <p>Spanner Llave Spanner</p>
<p>7 x32</p>  <p>Flat Washer Lavadora plana Rondelle plate</p>		

# Assembly | Asamblea | Assemblage

1

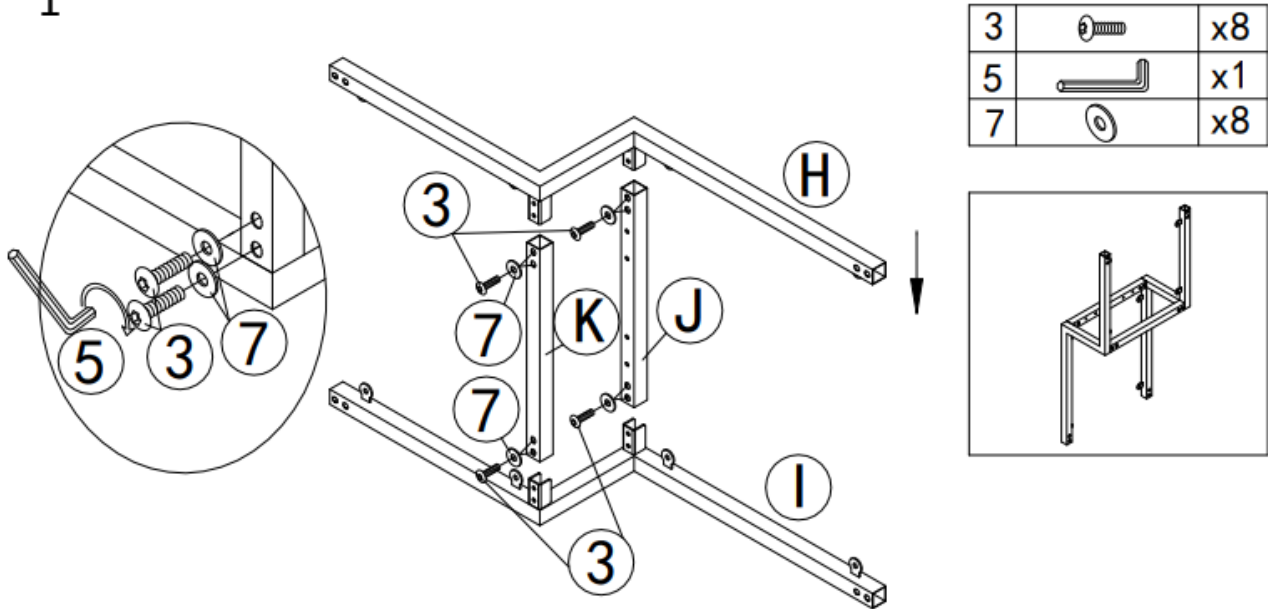

Do not fully tighten screws until all screws are in position.

No apriete completamente los tornillos hasta que estén en su posición.

Ne serrez pas complètement les vis tant que toutes les vis ne sont pas en place.

# Assembly | Asambla | Assemblage

2

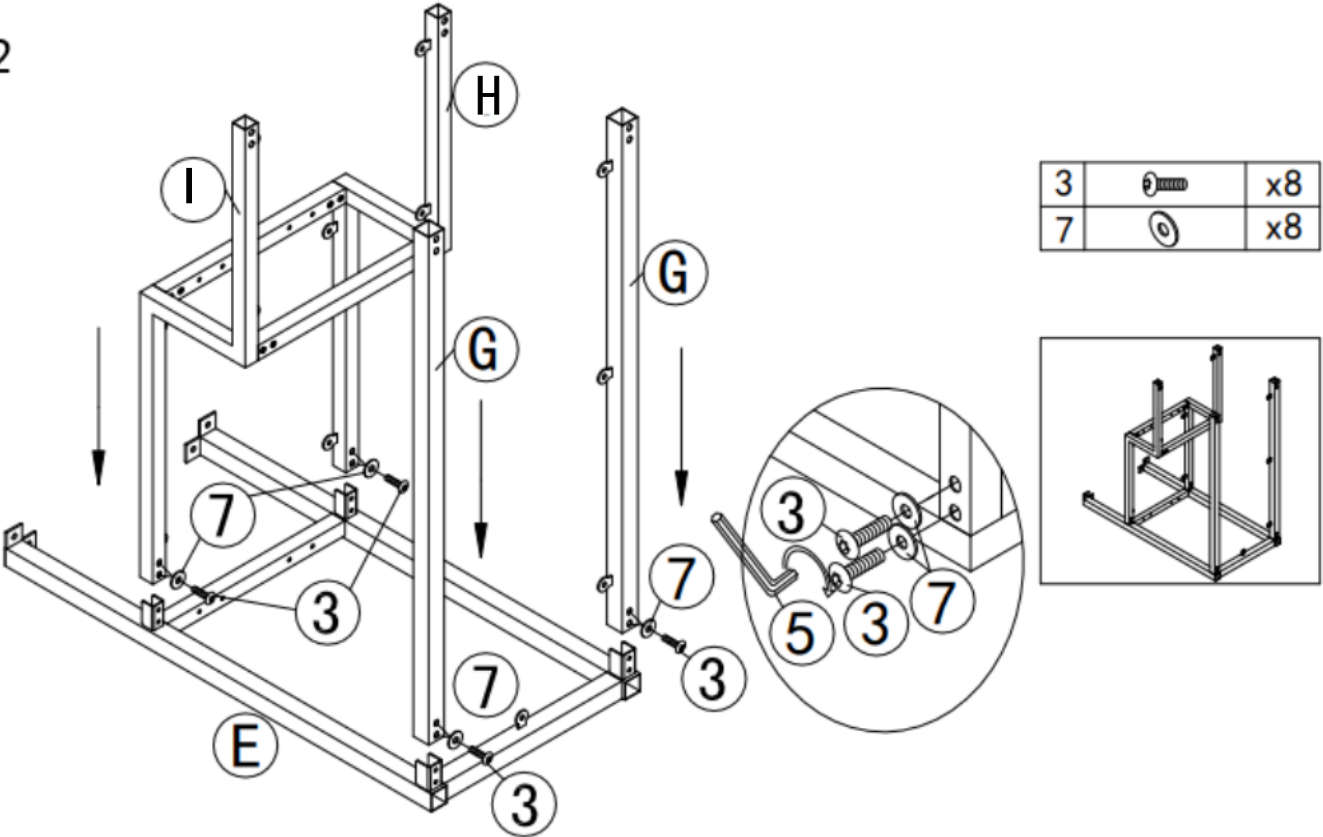



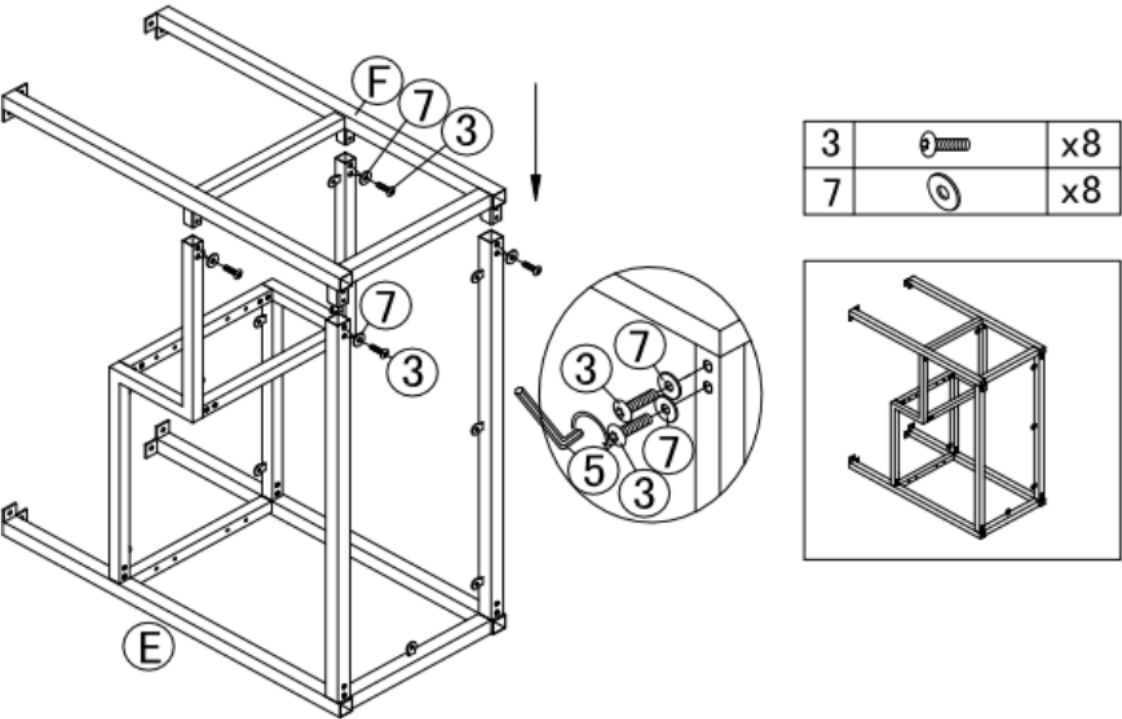

3

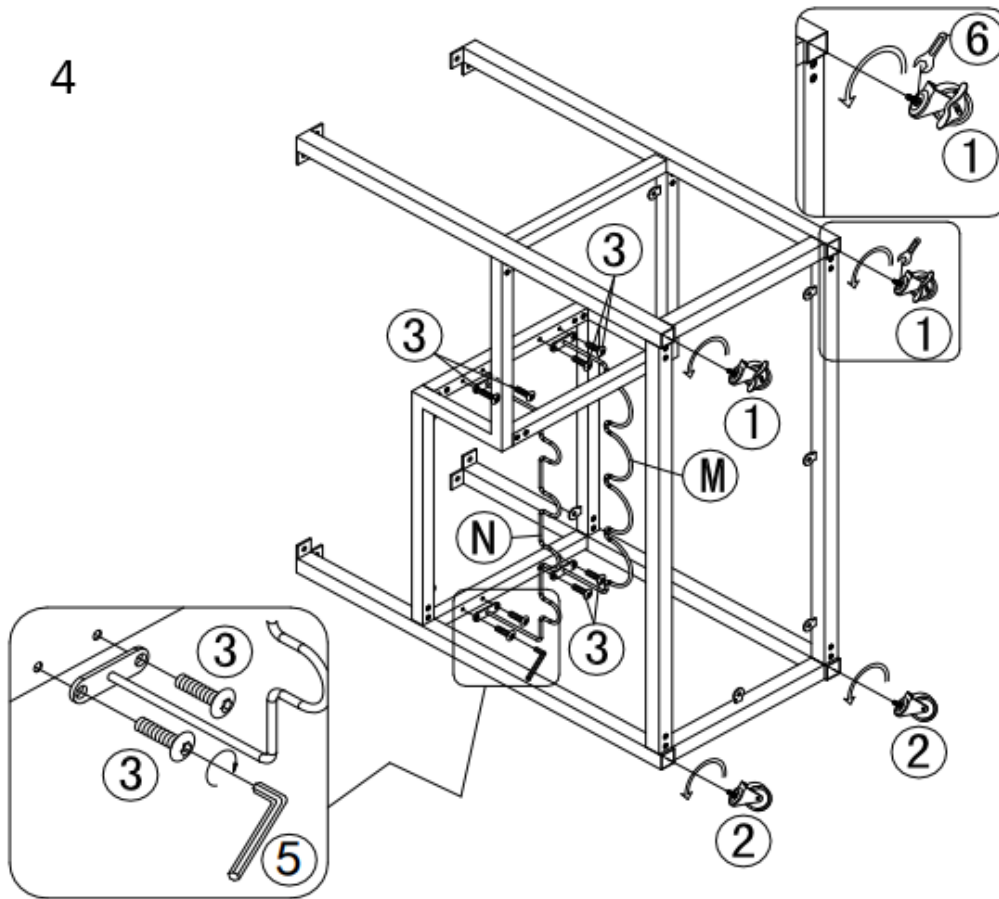

# Assembly | Asambla | Assemblage



1		x2
2		x2
3		x8
6		x1

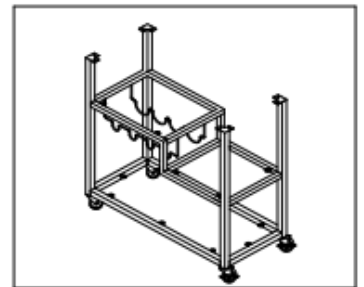

# Assembly | Asambla | Assemblage

5

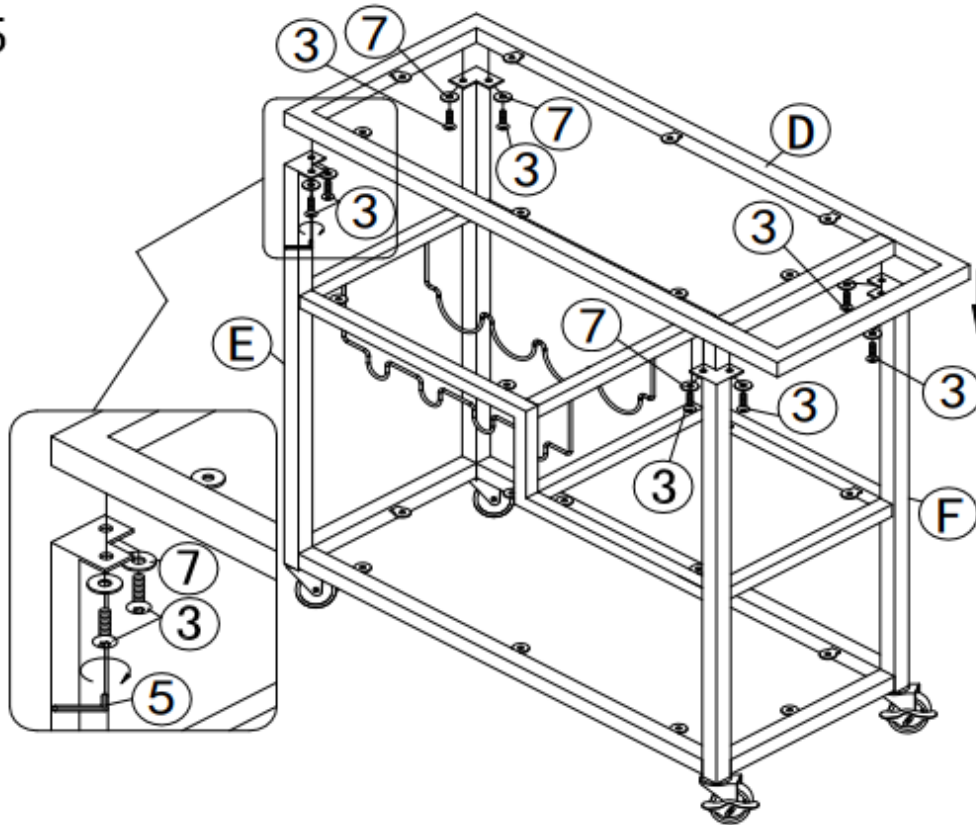

3		x8
7		x8

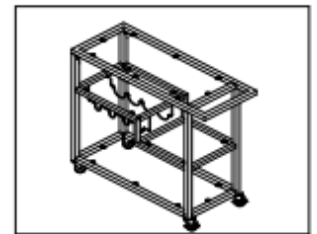

6

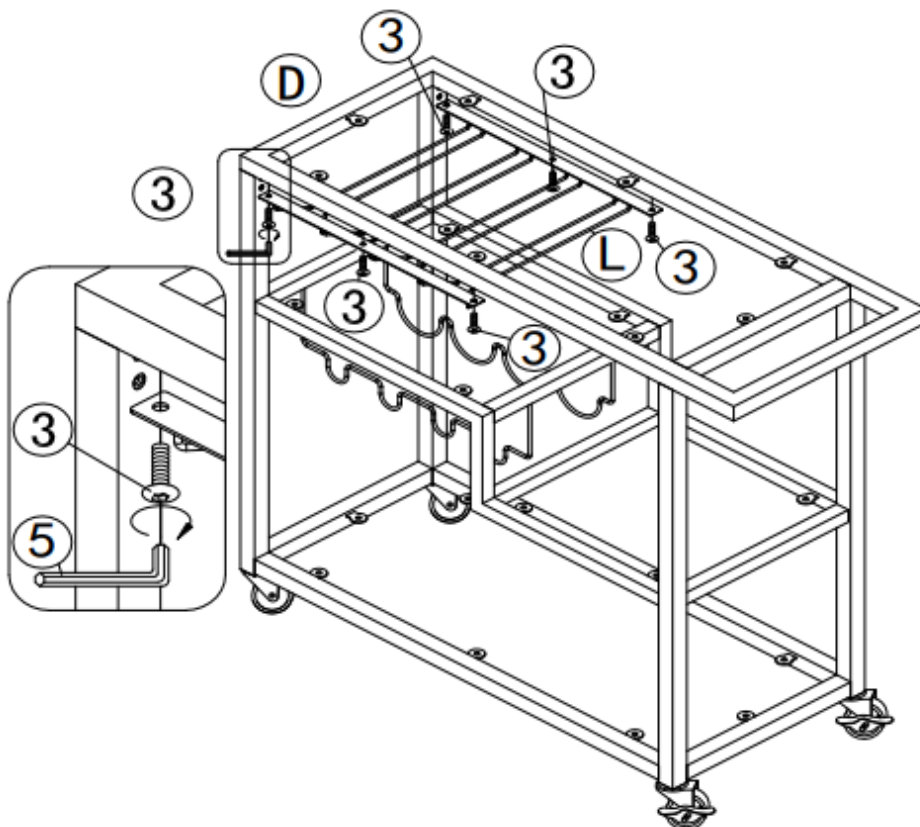

3		x6
---	---	----

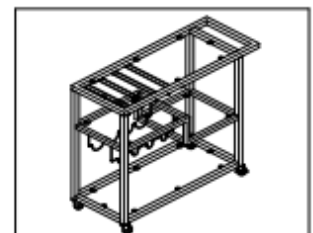

# Assembly | Asambla | Assemblage

7

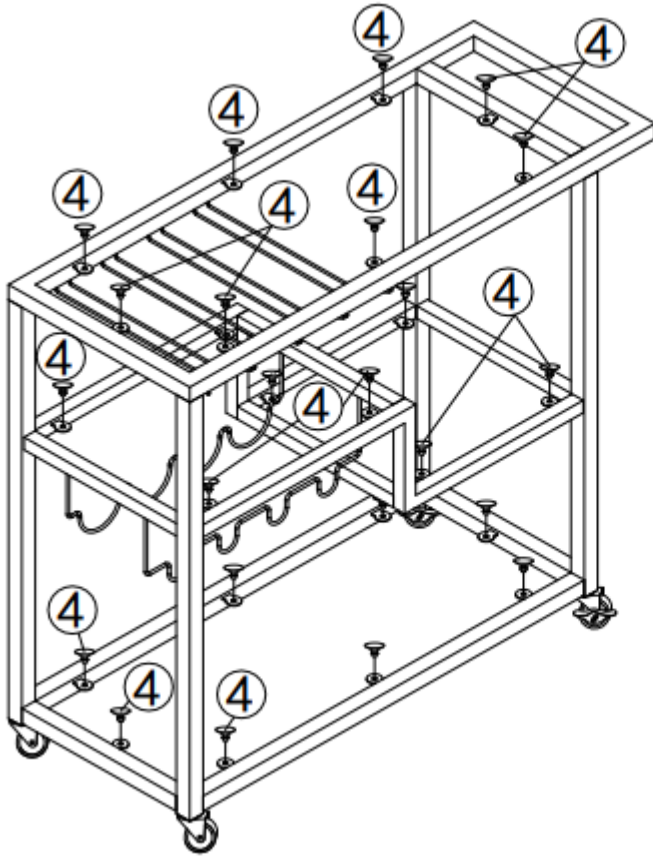

4		x24
---	---	-----

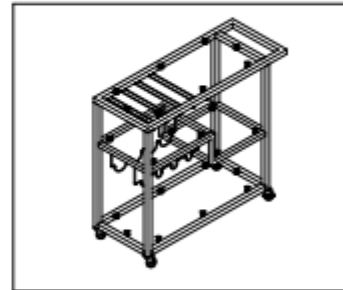

Tighten all screws.  
Apretar todos los tornillos.  
Serrez toutes les vis.

8

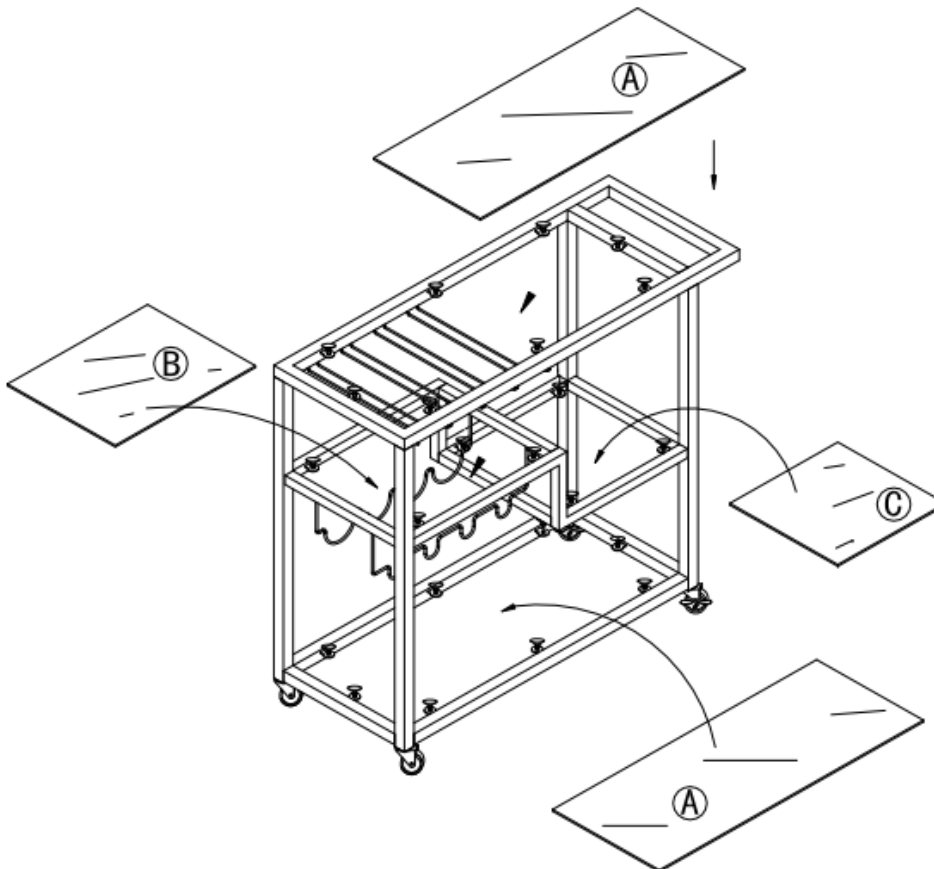

# Assembly | Asambla | Assemblage

9

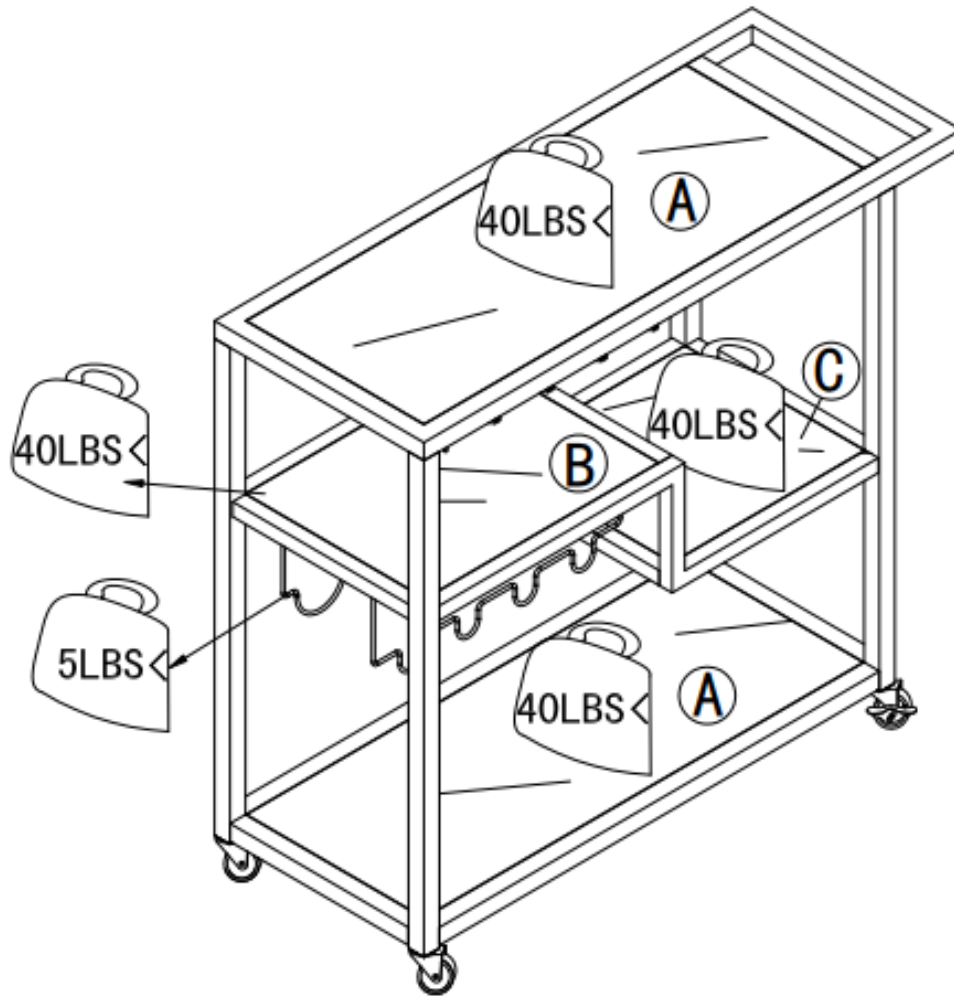

# Assembly | Asamblea | Assemblage

## Replacement Parts or Damages

Requests for missing or damaged parts must be requested within one year of purchase. Damages or missing parts reported outside of one year will not be honored. We are under no obligation to provide parts or replacement merchandise. Replacement part requests will not be honored for fully assembled or modified items.

For merchandise purchased from an online retailer, please contact their customer service for parts or returns.

Merchandise purchased as “like new,” “open box,” or “as is,” or from private parties are exempt from replacement parts.

## One Year Limited Warranty

Product warranty applies to the original purchaser with items in original factory-sealed cartons. Proof of purchase date, price, and seller must be shown to validate the warranty. This warranty covers defects in manufacturing. It does not apply to any defects caused by negligence, misuse, accidental damage, or improper assembly. Glass and mirrors are excluded from this warranty. Warranty does not extend to cosmetic damage, accidents, misuse, abuse, or neglect. Liability for incidental or consequential damages is excluded to the maximum extent permitted by law.

After verification of claim, we will repair or replace any defective product or missing part. If the defective item must be returned in whole or in part, we will send written authorization and a pre-addressed shipping label for the return of any defective product or part.

No returns will be accepted without prior approval.

# Assembly | Asamblea | Assemblage

## Piezas de Repuesto o Daños

Las solicitudes de piezas faltantes o dañadas deben solicitarse en el plazo de un año a partir de la compra. Los daños o piezas faltantes informados fuera de un año no serán aceptados. No tiene la obligación de proporcionar piezas o mercadería de reemplazo. No se aceptarán solicitudes de piezas de repuesto para artículos completamente ensamblados o modificados.

Para mercadería comprada en un minorista en línea, comuníquese con su servicio de atención al cliente para obtener piezas o devoluciones.

La mercancía comprada como "como nueva", "caja abierta" o "como está" o de particulares están exentas de piezas de repuesto.

## Garantía Limitada de un Año

La garantía del producto se aplica al comprador original con los artículos en cajas de cartón originales selladas de fábrica. Se debe mostrar el comprobante de la fecha de compra, el precio y el vendedor para validar la garantía. Esta garantía cubre defectos de fabricación. No se aplica a ningún defecto causado por negligencia, mal uso, daño accidental o montaje inadecuado. Los vidrios y espejos están excluidos de esta garantía. La garantía no se extiende a daños cosméticos, accidentes, mal uso, abuso o negligencia. La responsabilidad por daños incidentales o consecuentes está excluida en la medida máxima permitida por la ley.

Después de la verificación de la reclamación, reparará o reemplazará cualquier producto defectuoso o pieza faltante. Si el artículo defectuoso debe devolverse en su totalidad o en parte, le enviaremos una autorización por escrito y una etiqueta de envío con la dirección predeterminada para la devolución de cualquier producto o pieza defectuosa.

No se aceptarán devoluciones sin aprobación previa.

# Assembly | Asamblea | Assemblage

## Pièces de Rechange ou Dommages

Les demandes de pièces manquantes ou endommagées doivent être effectuées dans l'année suivant l'achat. Les dommages ou pièces manquantes signalés en dehors d'un an ne seront pas honorés. n'a aucune obligation de fournir des pièces ou des marchandises de remplacement. Les demandes de pièces de rechange ne seront pas honorées pour les articles entièrement assemblés ou modifiés.

Pour les marchandises achetées auprès d'un détaillant en ligne, veuillez contacter leur service client pour les pièces ou les retours.

Les marchandises achetées comme “comme neuves”, “boîte ouverte” ou “en l'état” ou auprès de parties privées sont exemptées de pièces de rechange.

## Garantie Limitée d'un An

La garantie du produit s'applique à l'acheteur d'origine avec des articles dans des cartons d'origine scellés en usine. La date d'achat, le prix et le vendeur doivent être présentés pour valider la garantie. Cette garantie couvre les défauts de fabrication. Elle ne s'applique pas aux défauts causés par une négligence, une mauvaise utilisation, des dommages accidentels ou un assemblage incorrect. Le verre et les miroirs sont exclus de cette garantie. La garantie ne s'étend pas aux dommages cosmétiques, aux accidents, à la mauvaise utilisation, à l'abus ou à la négligence. La responsabilité pour les dommages accessoires ou indirects est exclue dans la mesure maximale permise par la loi.

Après vérification de la réclamation, réparera ou remplacera tout produit défectueux ou pièce manquante. Si l'article défectueux doit être retourné en tout ou en partie, nous vous enverrons une autorisation écrite et une étiquette d'expédition pré-adressée pour le retour de tout produit ou pièce défectueux.

Aucun retour ne sera accepté sans accord préalable.