

# ASSEMBLY INSTRUCTIONS

## MANUAL DE MONTAGEM / INSTRUCCIONES DE ARMADO

Office table  
Mesa  
Escritorio

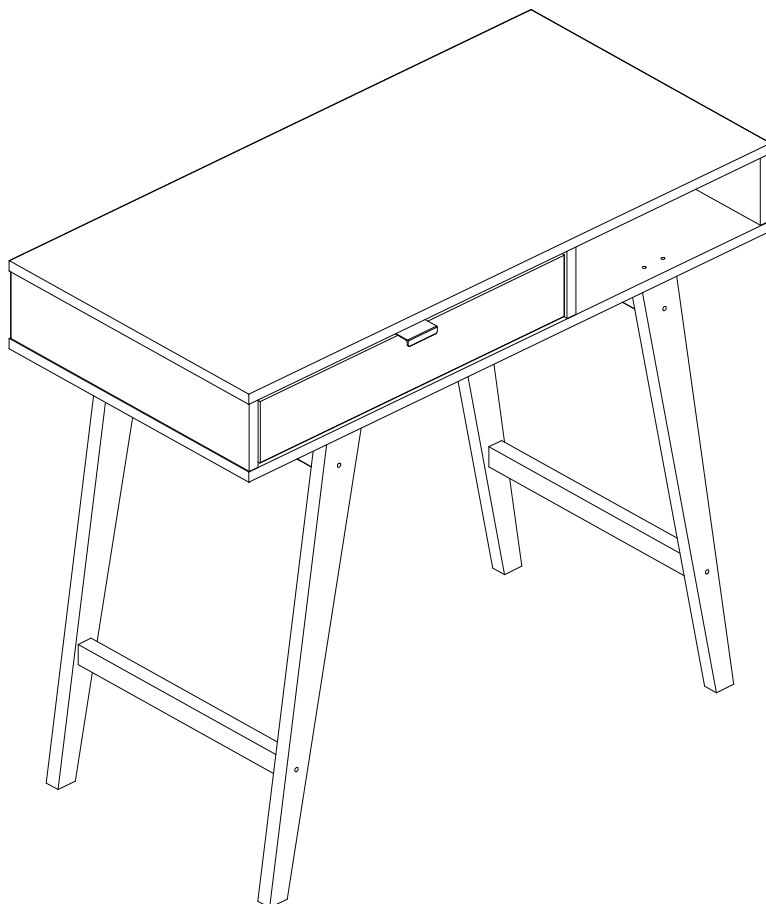

### YOU WILL NEED / VOCÊ VAI PRECISAR DE / USTED NECESITARÁ

#### Tools not supplied / Ferramentas não fornecidas / Herramientas no incluidas

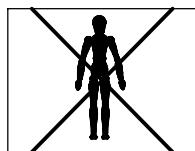

1 Person  
1 Pessoa  
1 Persona

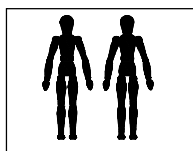

2 People  
2 Pessoas  
2 Personas

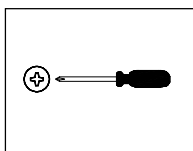

Screwdriver Phillips  
Chave Phillips  
Destornillador cruz

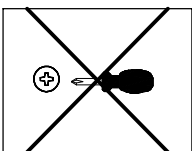

Small screwdriver Phillips  
Chave Phillips Menor  
Destornillador cruz menor

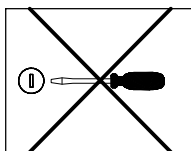

Screwdriver slotted  
Chave fenda  
Destornillador plano

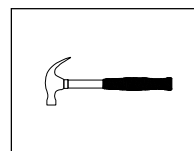

Hammer  
Martelo  
Martillo

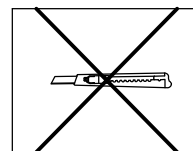

Stylet  
Estilete  
Estilete



Drill machine  
Furadeira  
Taladro

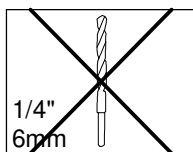

Drill bit  
Broca  
Taladro

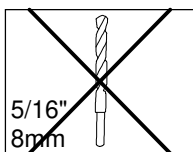

Drill bit  
Broca  
Taladro

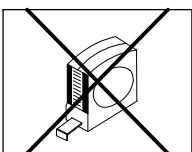

Measuring tape  
Trena  
Cinta de medición

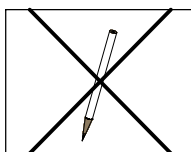

Pencil  
Lápis  
Lápis

**NOTES:** The separation of the accessories before you start the assembly will facilitate the same. In case of doubt on the size of the screws and bolts, use the ruler to bottom of page 3.

**NOTAS:** A separação dos acessórios antes de iniciar a montagem facilitará a mesma. Em caso de dúvida no tamanho dos parafusos e cavilhas, utilize a régua ao final da página 3.

**NOTAS:** La separación de los accesorios antes de comenzar el armado facilitará el mismo. En caso de duda sobre el tamaño de los tornillos y taquetes, utilice la regla al pie de página 3.

MAXIMUM RECOMMENDED WEIGHT  
BEING THIS EVENLY DISTRIBUTED

PESO MÁXIMO RECOMENDADO SENDO  
ESTE DISTRIBUÍDO UNIFORMEMENTE

PESO MÁXIMO RECOMENDADO SIENDO  
ESTE UNIFORMEMENTE DISTRIBUIDO

	LB	KG
<b>A</b>	44	20
<b>B</b>	22	10
<b>C</b>	6	3

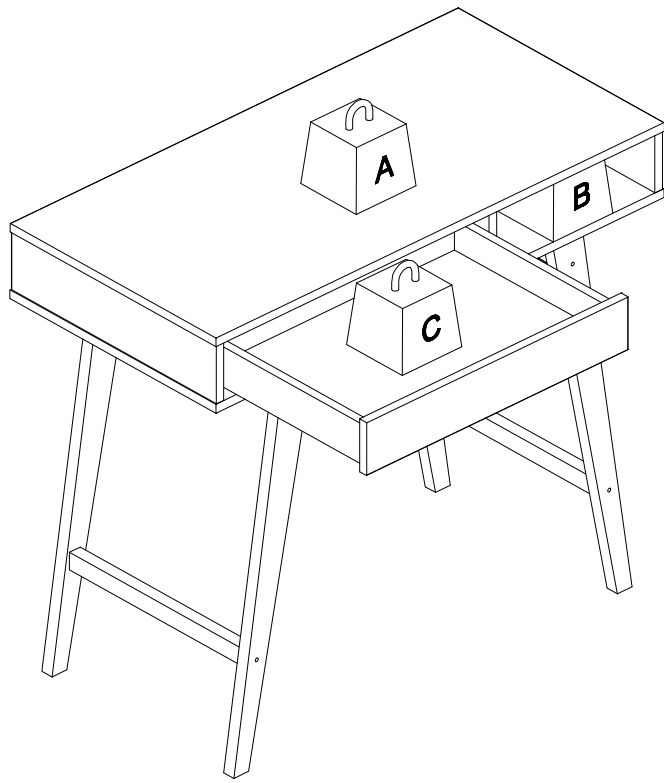





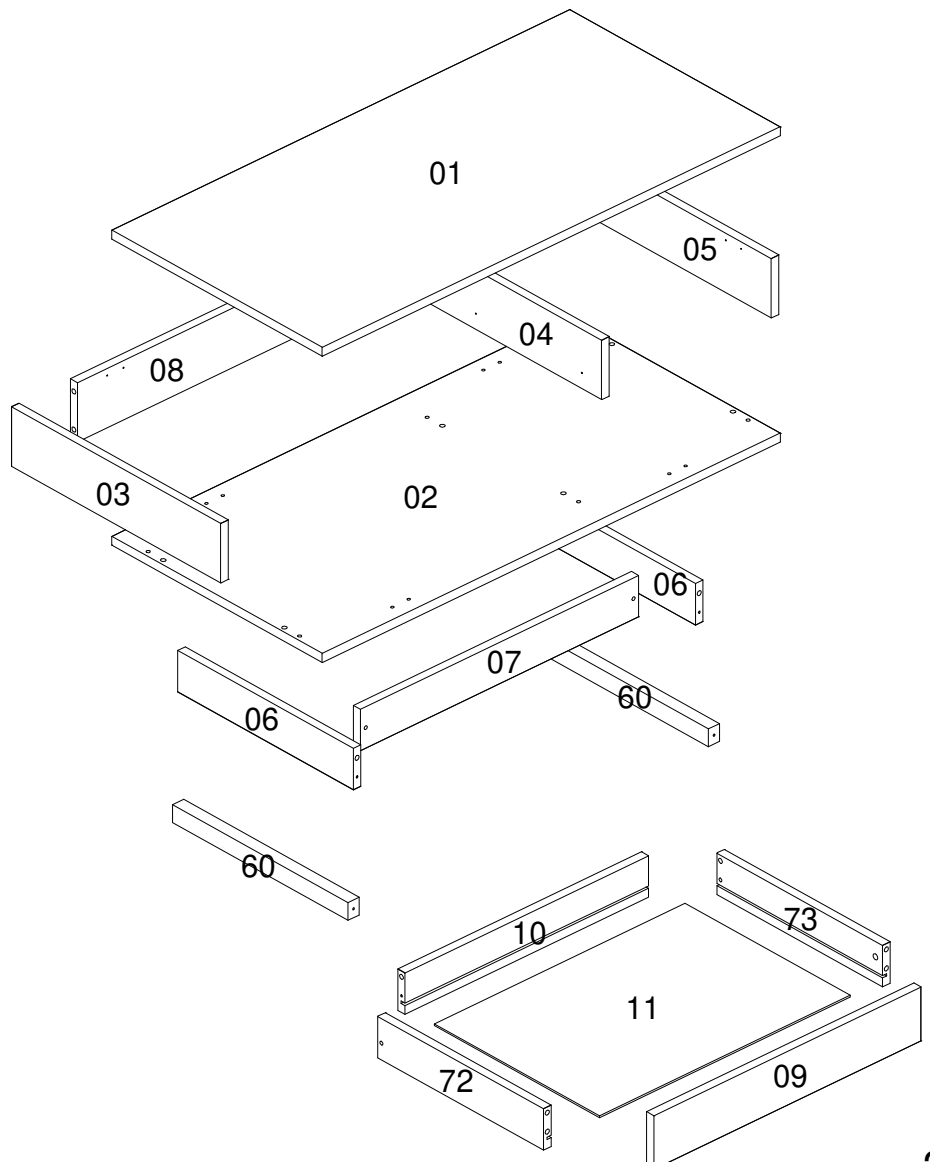





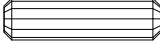
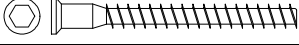

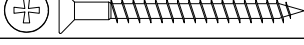
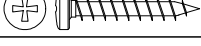

Nº	Measures Inches	Medidas cm	Qty./Qtd.
01	35" 1/2 x 17" 1/2 x 5/8	90 x 44,5 x 1,5	1
02	35" 1/2 x 17" 1/2 x 5/8	90 x 44,5 x 1,5	1
03	4" x 17" 1/2 x 5/8	10 x 44,3 x 1,5	1
04	4" x 17" 1/2 x 5/8	10 x 44,3 x 1,5	1
05	4" x 17" 1/2 x 5/8	10 x 44,3 x 1,5	1
06	14" 5/8 x 2" 3/4 x 5/8	37,1 x 7 x 1,5	2
07	21" 1/2 x 2" 3/4 x 5/8	54,6 x 7 x 1,5	1
08	21" x 4" x 5/8	53,3 x 10 x 1,5	1
09	20" 5/8 x 3" 5/8 x 5/8	52,5 x 9,1 x 1,5	1
10	18" 3/4 x 2" 3/4 x 5/8	47,8 x 7 x 1,5	1
11	19" 3/8 x 13" 3/4 x 5/8	49,2 x 34,9 x 1,5	1
60	14" 5/8 x 1" 1/4 x 7/8	37,1 x 3 x 2,2	2
72	13" 3/4 x 2" 3/4 x 5/8	35 x 7 x 1,5	1
73	13" 3/4 x 2" 3/4 x 5/8	35 x 7 x 1,5	1

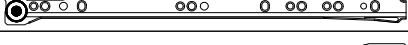
**PARTS IDENTIFICATION**  
**IDENTIFICAÇÃO DAS PEÇAS / IDENTIFICACIÓN DE LAS PIEZAS**

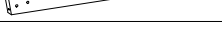

## IDENTIFICATION OF ACCESSORIES IDENTIFICAÇÃO DOS ACESSÓRIOS/ IDENTIFICACIÓN DE ACCESORIOS

A1		Glue / Cola / Pegamento	13 g	1
A3		Trapeze / Trapézio / Trapecio	-	2
B5		Metalic angle plates / Cantoneira de metal / Suporte de metal	46 mm	6
E		Wooden dowel / Cavilha / Taquete	8x30 mm	20
G		Structural screw / Parafuso estrutural / Tornillo estructural	5,0x50 mm	8
H		Allen key / Chave allen / Liave allen	3 mm	1
I		Structural screw cover/Tampa parafuso estrutural/Tapa tornillo estructural	-	4
M1		Flat head screw / Parafuso chato / Tornillo de cabeza plana	3,5x25 mm	2
O		Flat head screw / Parafuso chato / Tornillo de cabeza plana	4,5x45 mm	16
P		Pan head screw / Parafuso panela / Tornillo de pan	4,5x25 mm	2
P5		Flat head screw / Parafuso chato especial / Tornillo de cabeza plana	3,5x14 mm	10
S		Pan head screw / Parafuso panela / Tornillo de pan	3,5x14 mm	24
VA		Metallic slide the left field / Corrediça lateral esquerda / Corredera lateral izquierda	350 mm	1
VB		Metallic slide the right field / Corrediça lateral direita / Corredera lateral derecha	350 mm	1
VC		Drawer slide left / Corrediça gaveta esquerda / Corredera izquierda cajón	350 mm	1
VD		Drawer slide right / Corrediça gaveta direita / Corredera derecha cajón	350 mm	1
X4		Handle / Puxador Stile Alfa / Tirador	32 mm	1
X9A		Foot / Pé angular / Pie	655 mm	2
X9B		Foot / Pé angular / Pie	655 mm	2



**PRE-ASSEMBLE  
PRÉ-MONTAGEM / PRE ARMADO**

**01**

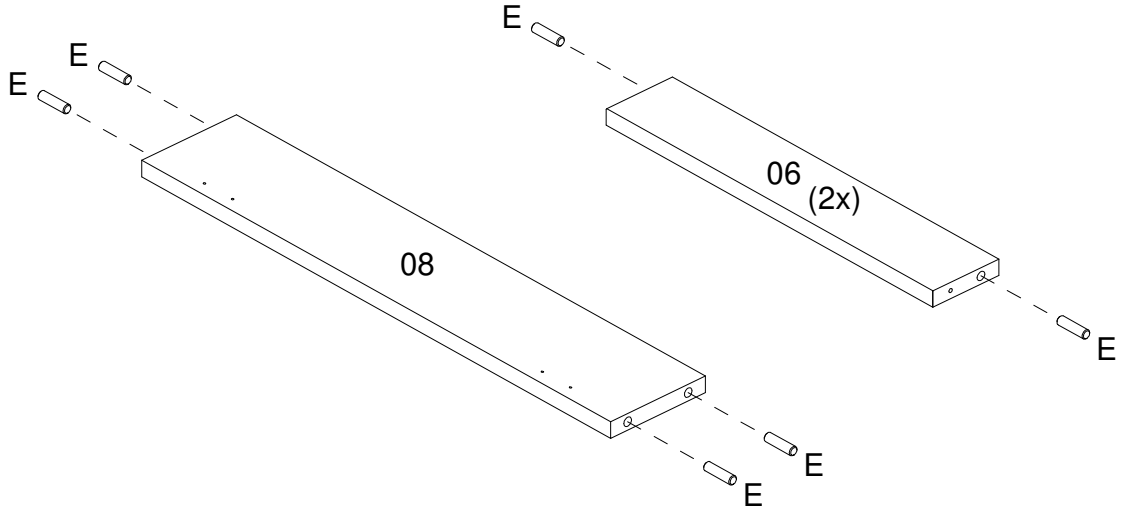
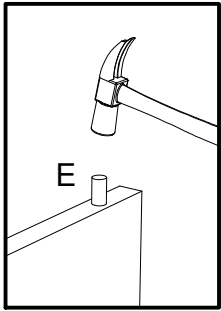

**02**

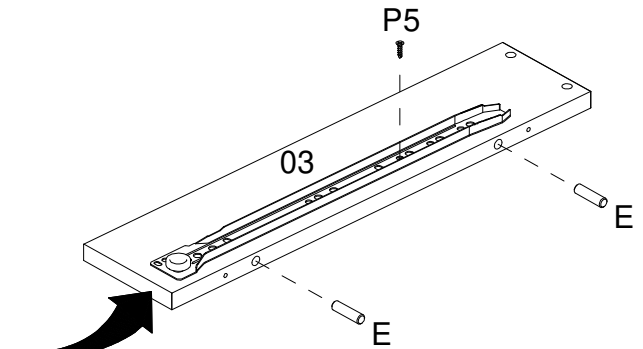
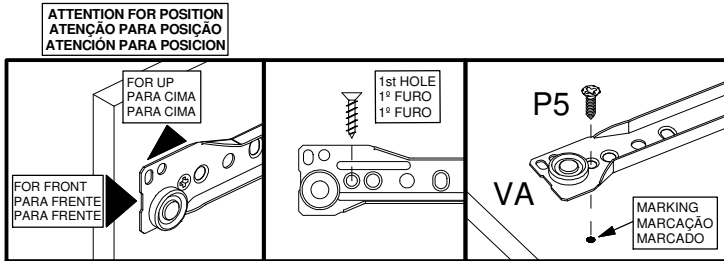

**03**

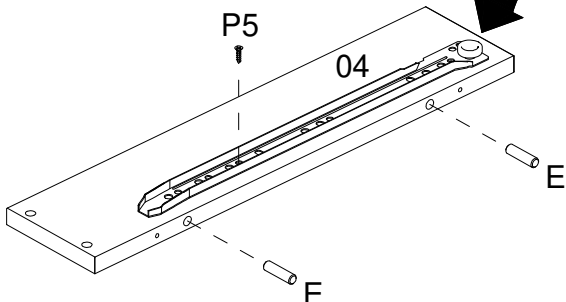
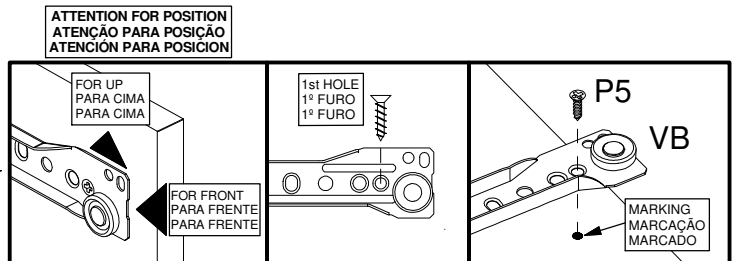

04

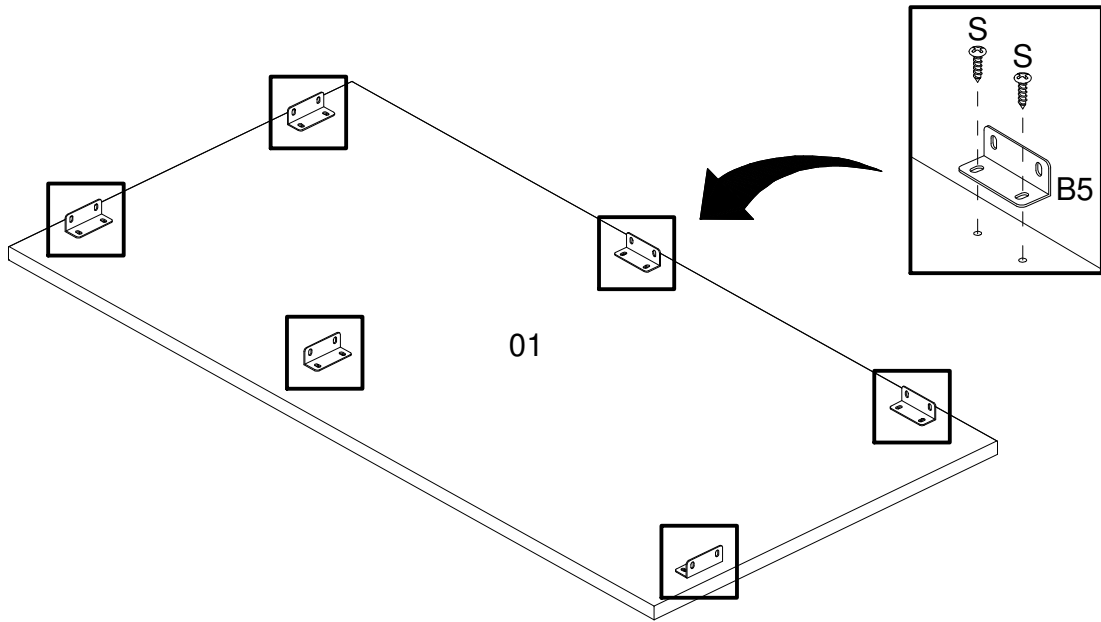

05

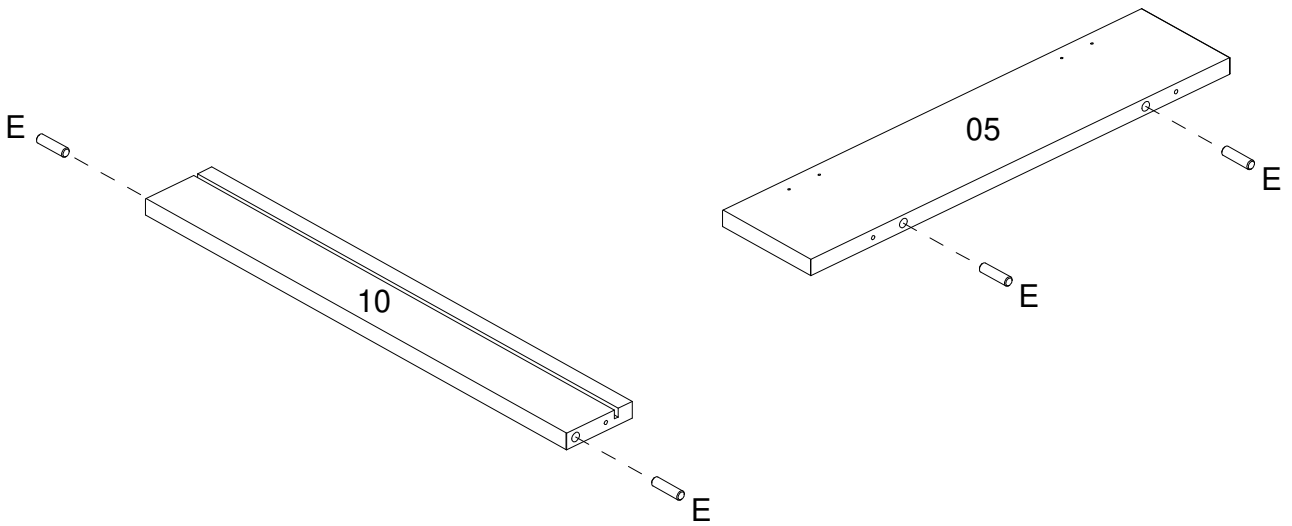

06

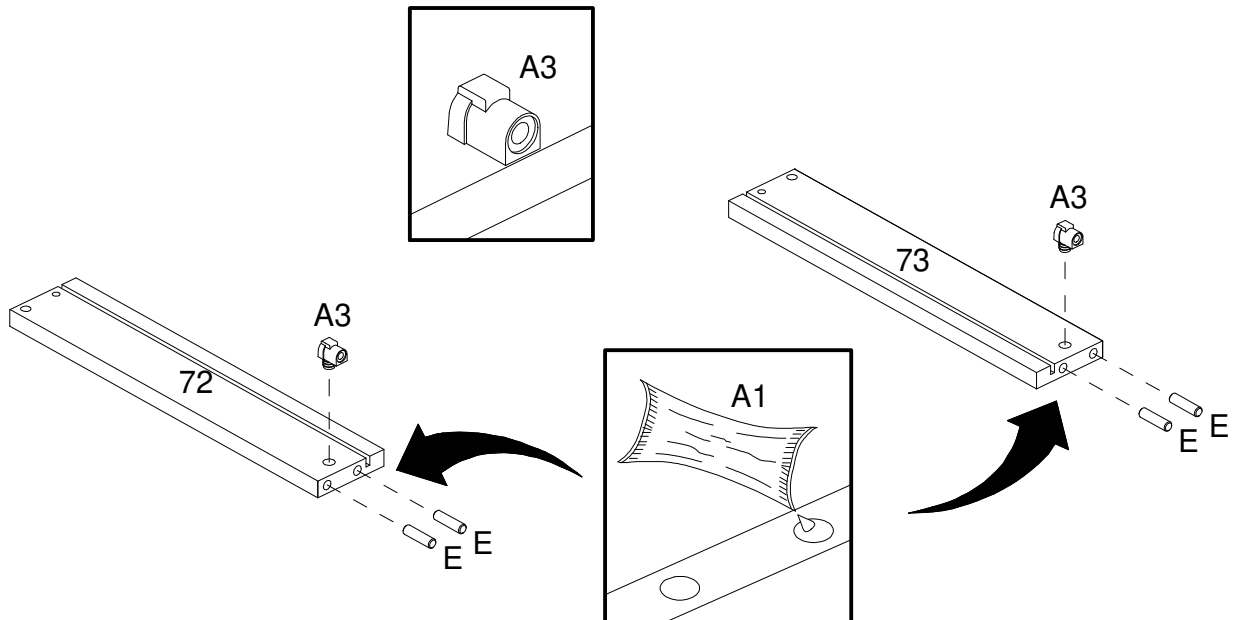

ASSEMBLY  
MONTAGEM / ARMADO

07

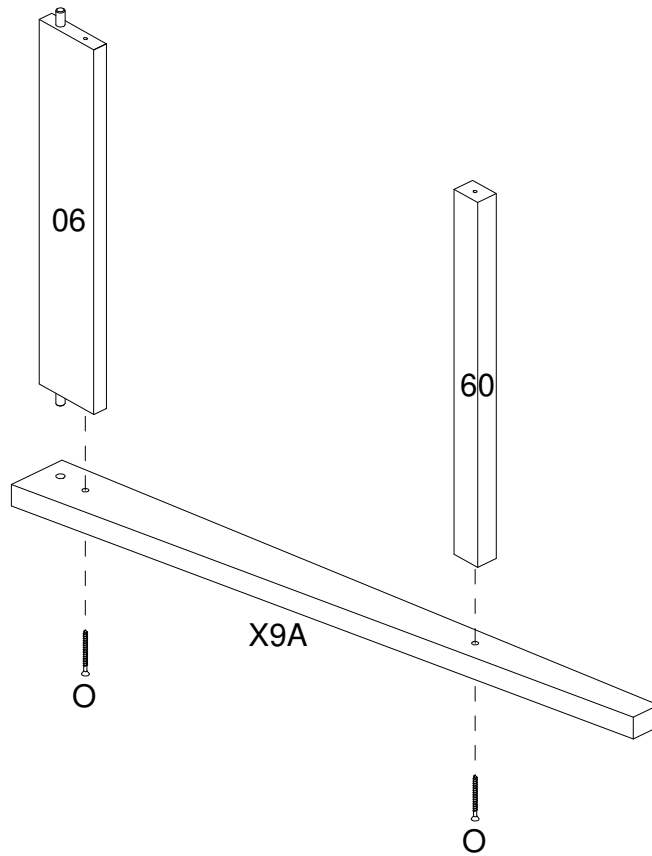

08

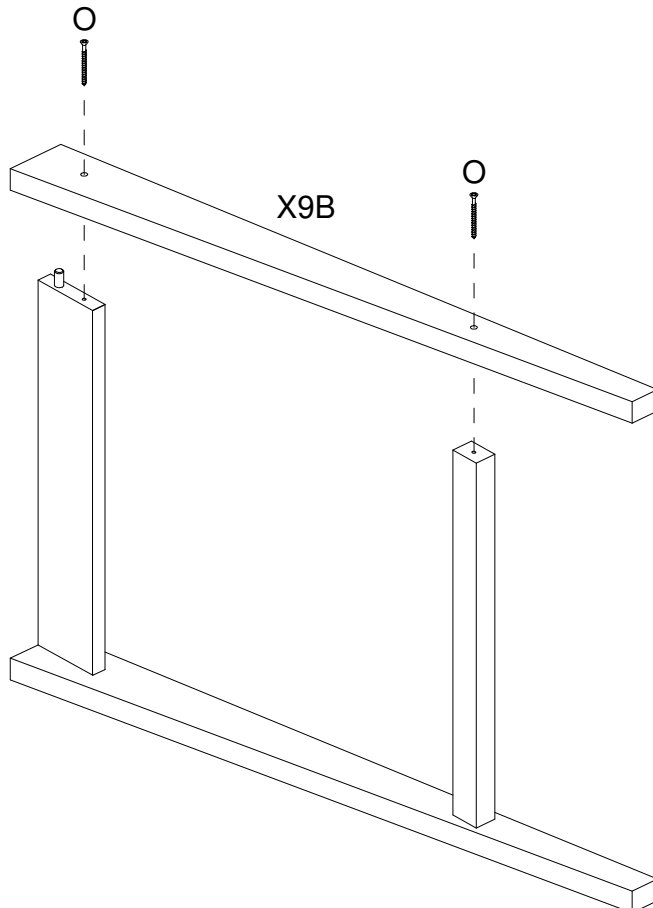

09

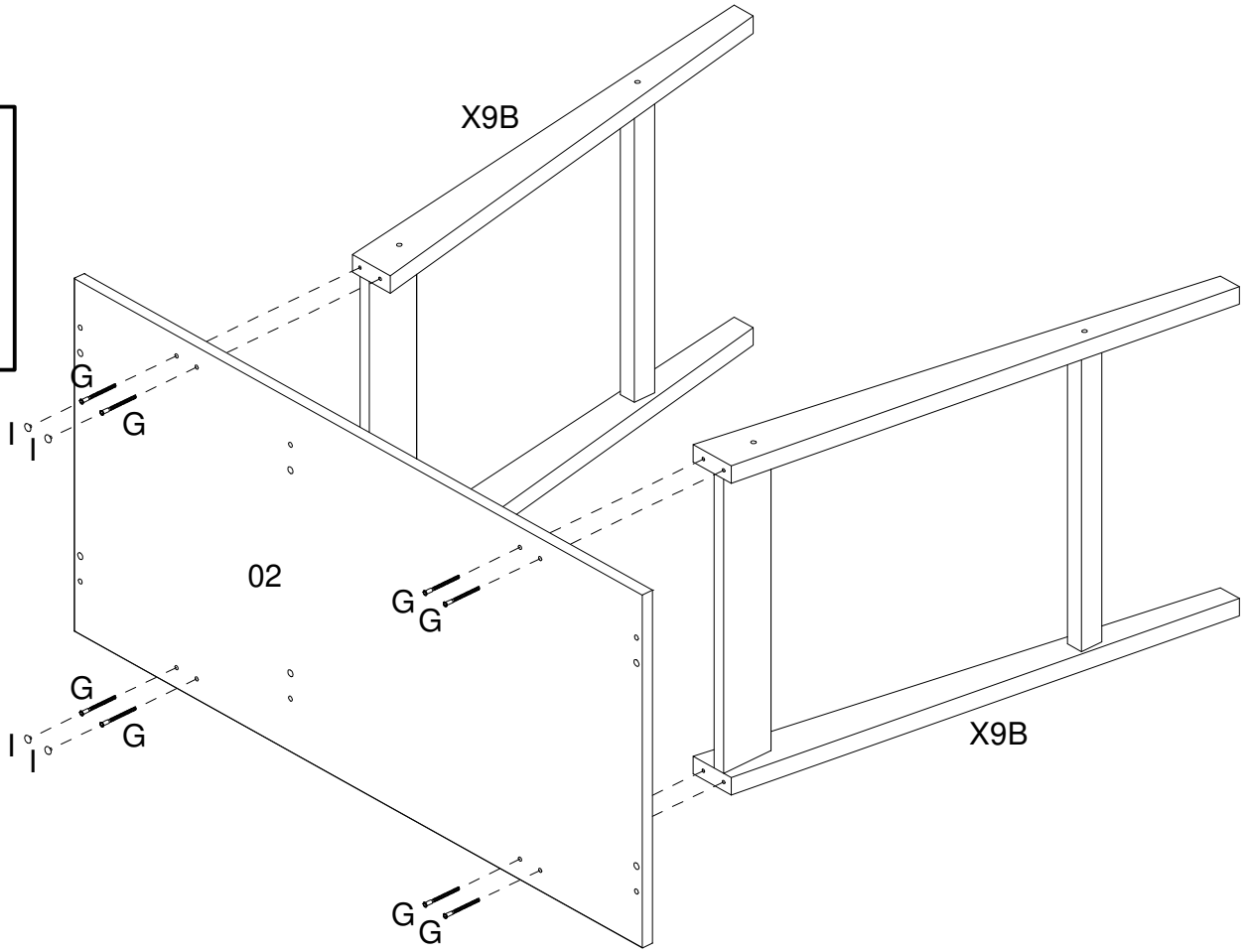
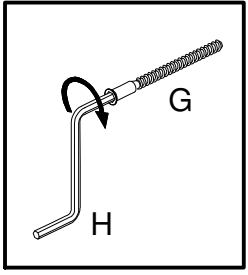

10

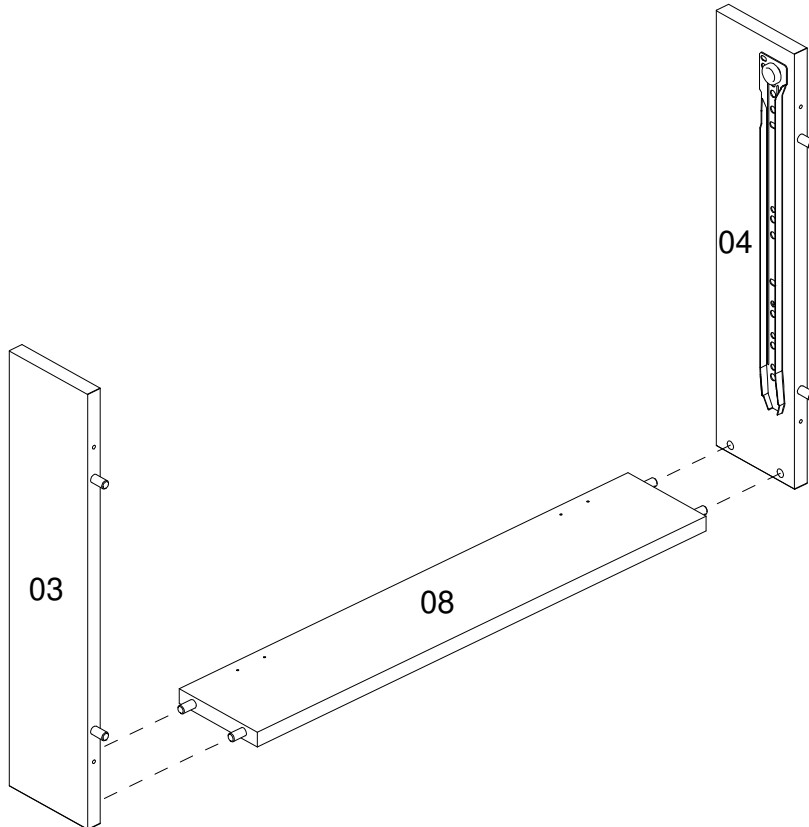

11

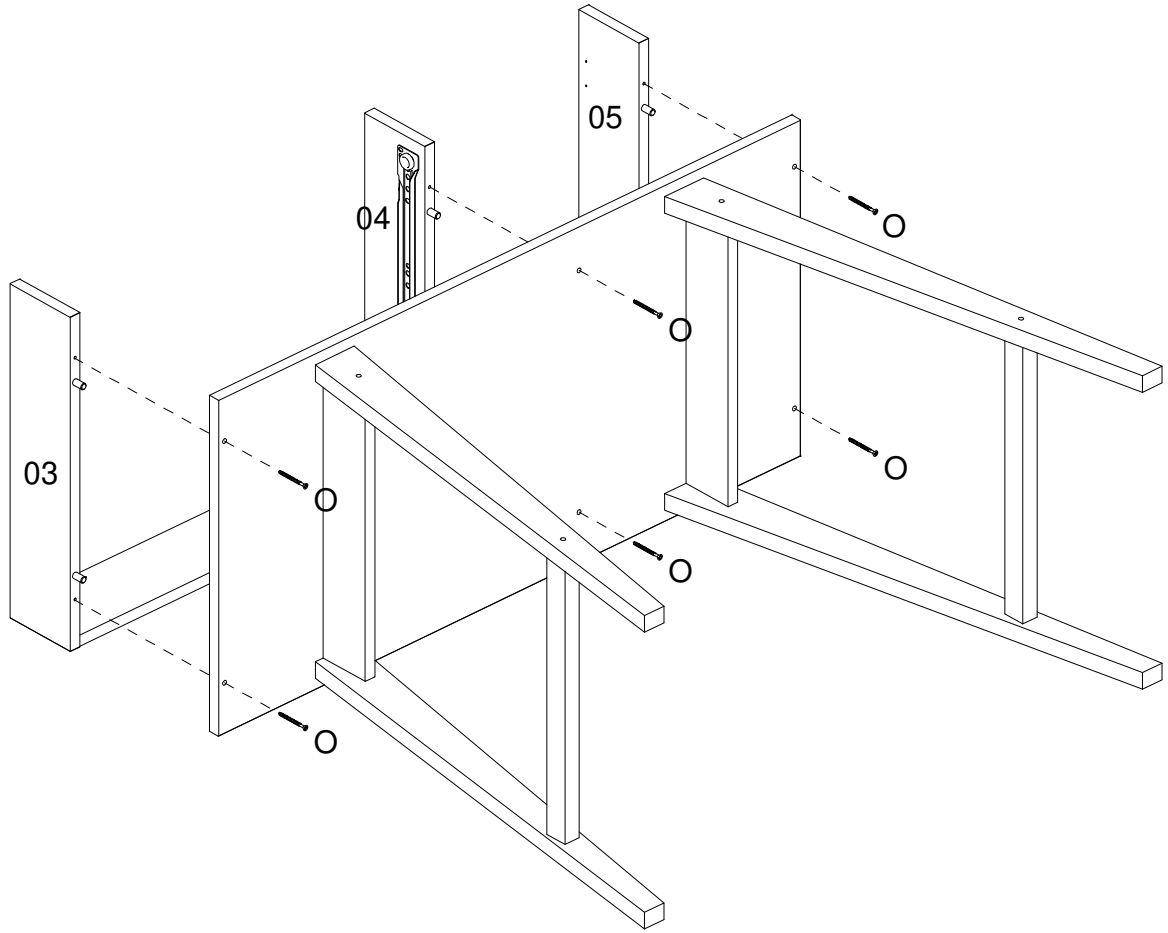

12

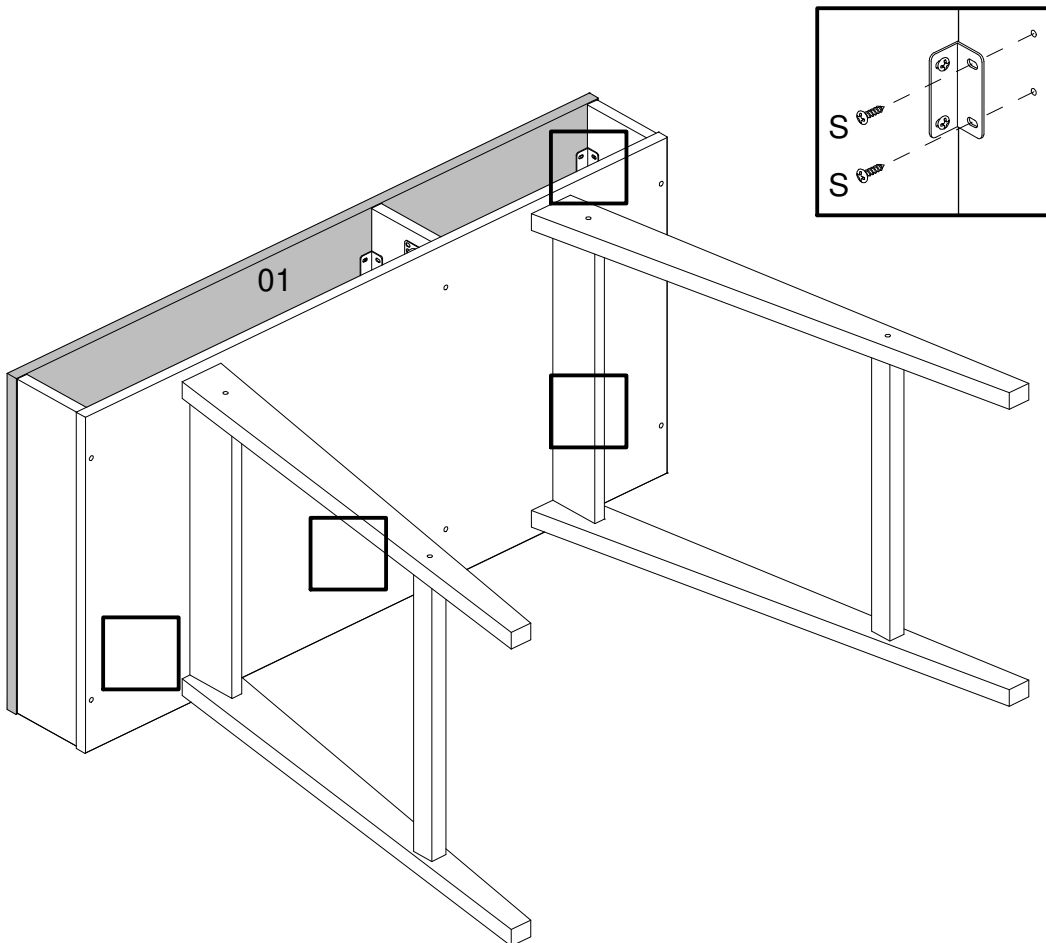



13

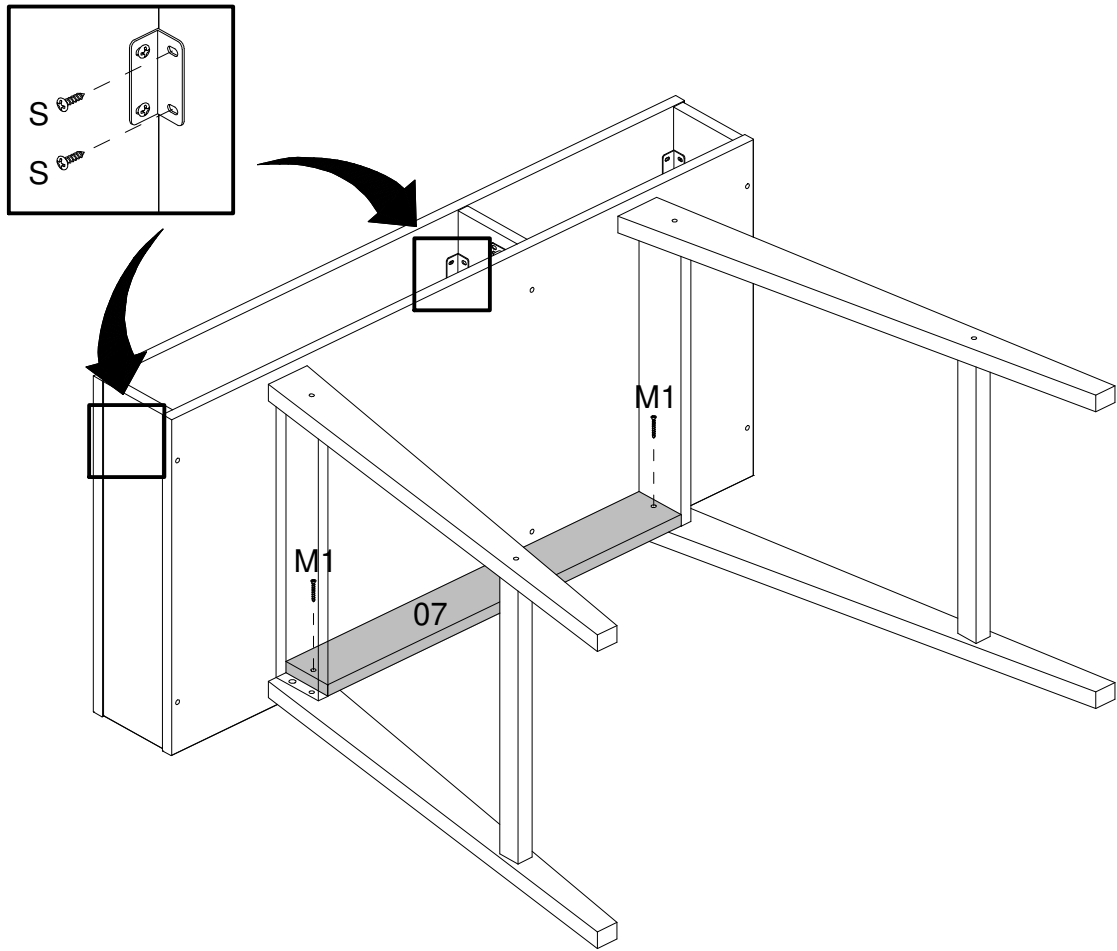

14

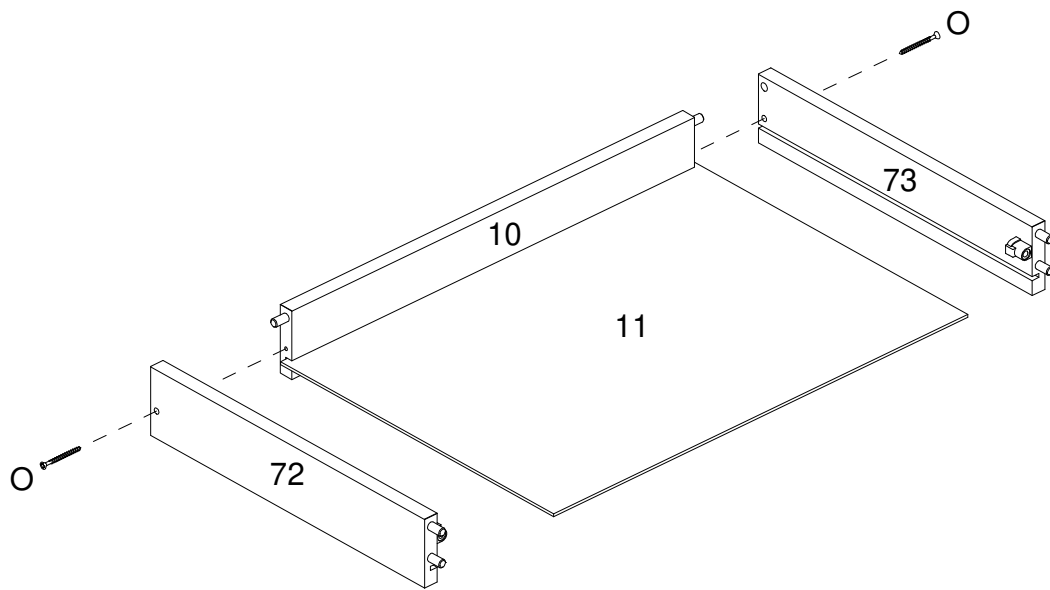

15

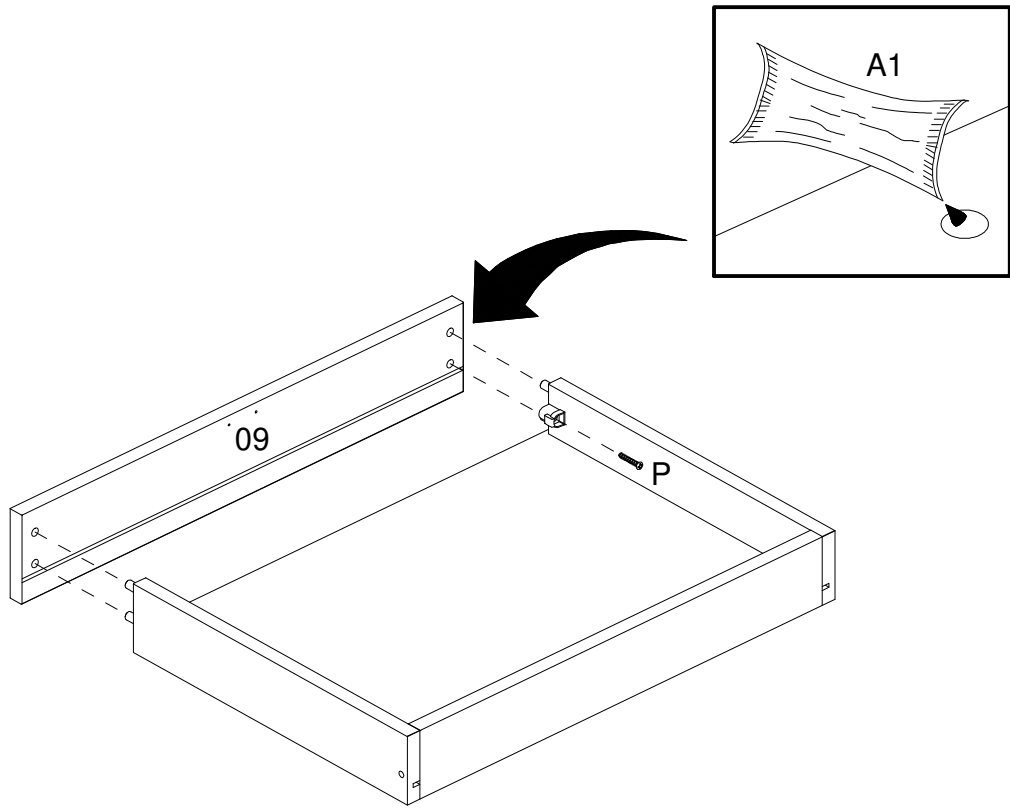

16

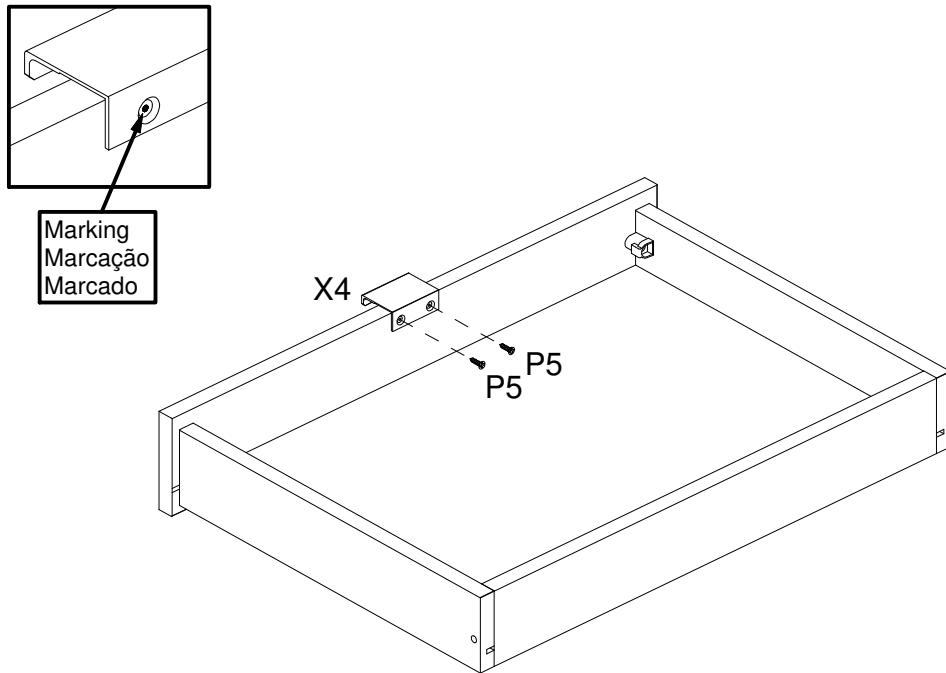

17

THE UNDERSIDE OF THE DRAWER  
LADO INFERIOR DA GAVETA  
PARTE INFERIOR DEL CAJÓN

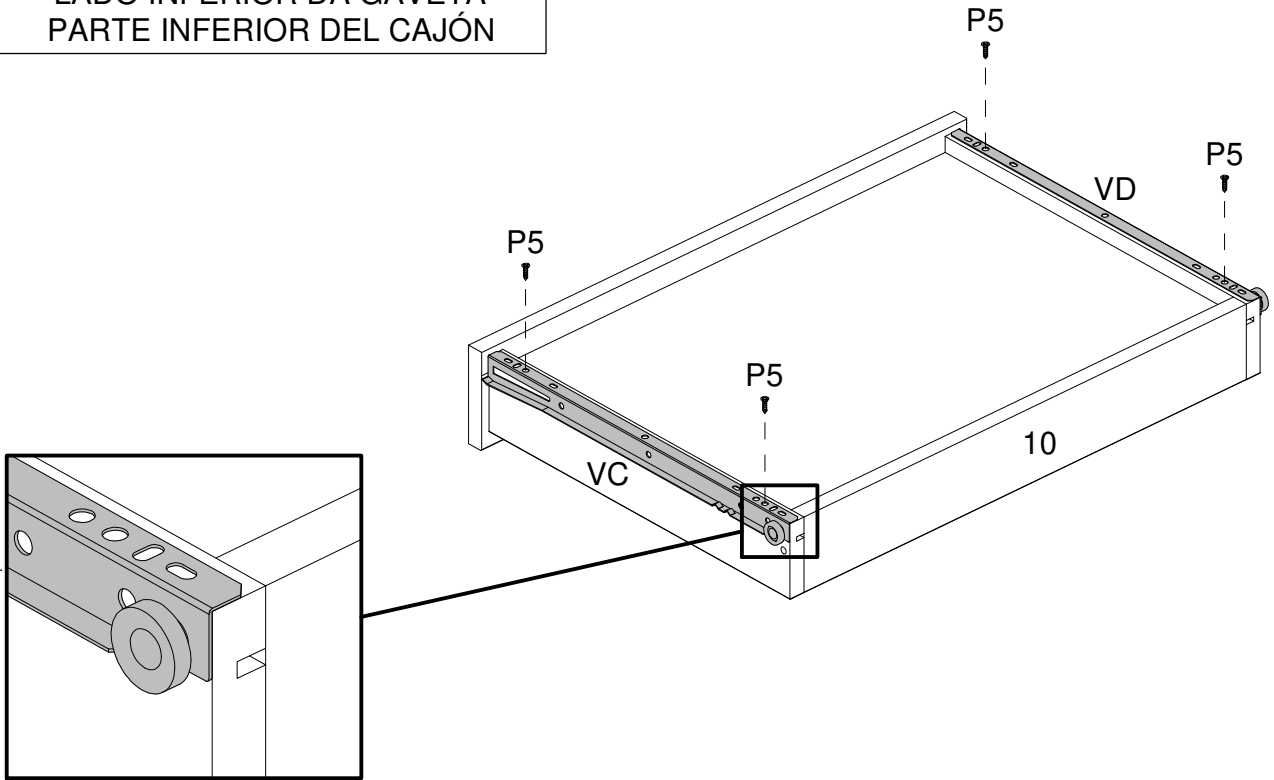

18

