

ASSEMBLY INSTRUCTION

BENCH

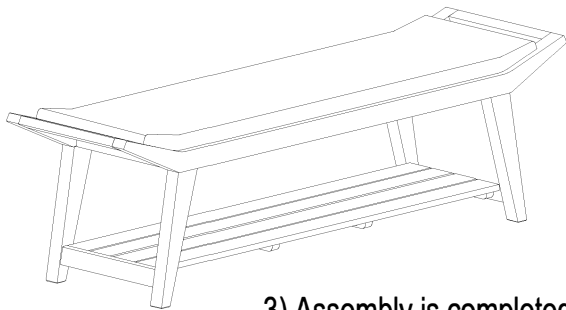

3) Assembly is completed.

IMPORTANT NOTES :

- . Place all wooden parts on a clean and smooth surface such as a rug or carpet to prevent the parts from being scratched.
- . Check to be sure that you have all parts and hardware.
- . Remove all wrapping materials, including staples and packing straps before you start to assemble.
- . Do not tighten all screws and bolts until completely assembled.
- . Keep all hardware out of the reach of children.

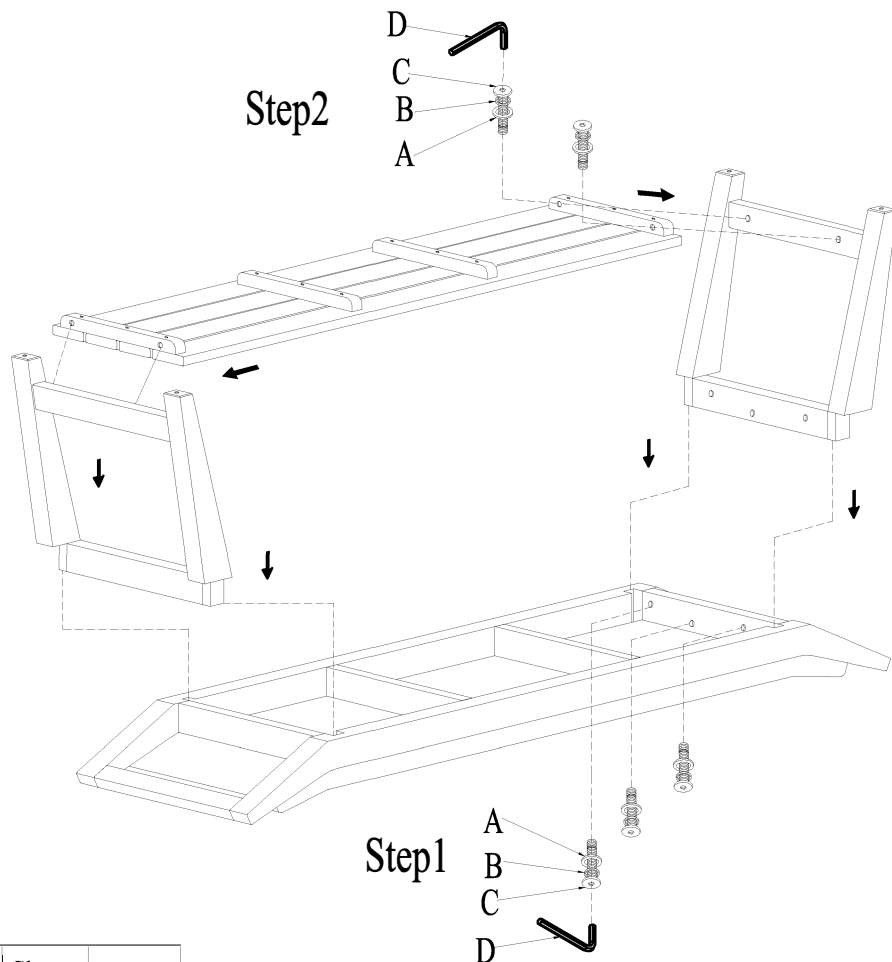

NO.	Dimension	Shape	Quantity
A	Flat Washer Ø5/16"*19mm		10pcs
B	Lock Washer Ø5/16"		10pcs
C	Bolt 5/16"*45mm		10pcs
D	Allen Key 4mm		1pc