

INTRODUCTION

Thank you for choosing the Drawer Dresser. Please read this user manual carefully and keep it for future reference. If you need any assistance, please contact us by email with your order number and details.







PACKAGE CONTENTS

- Drawer Dresser
- Pack of Accessories
- User Manual

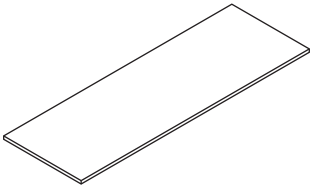
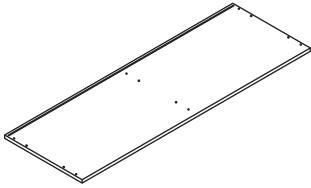
PRODUCT CARE

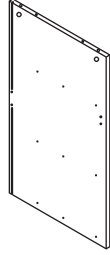
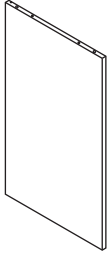
- Please follow the instruction to assemble this item correctly.
- Don't make the screws be too loose or too tight.
- Please put the screws into the holes' position just as shown in the arrows of the image, and then clockwise rotate 90° or 180°
- The fittings pack contains small accessories that should be kept away from small children.

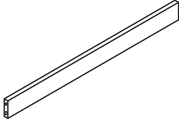
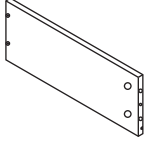
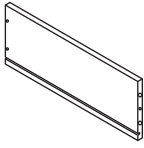
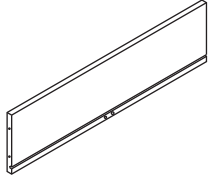
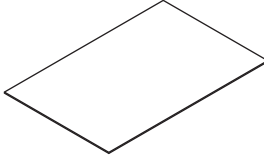
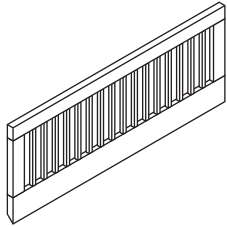
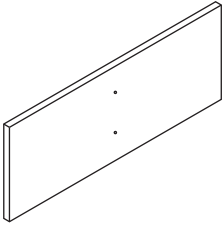
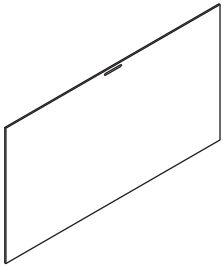
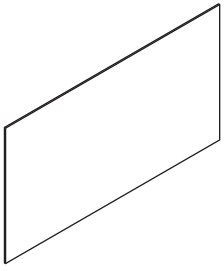
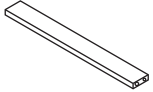
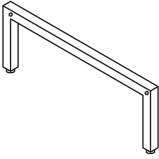
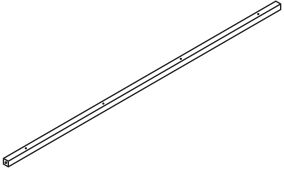





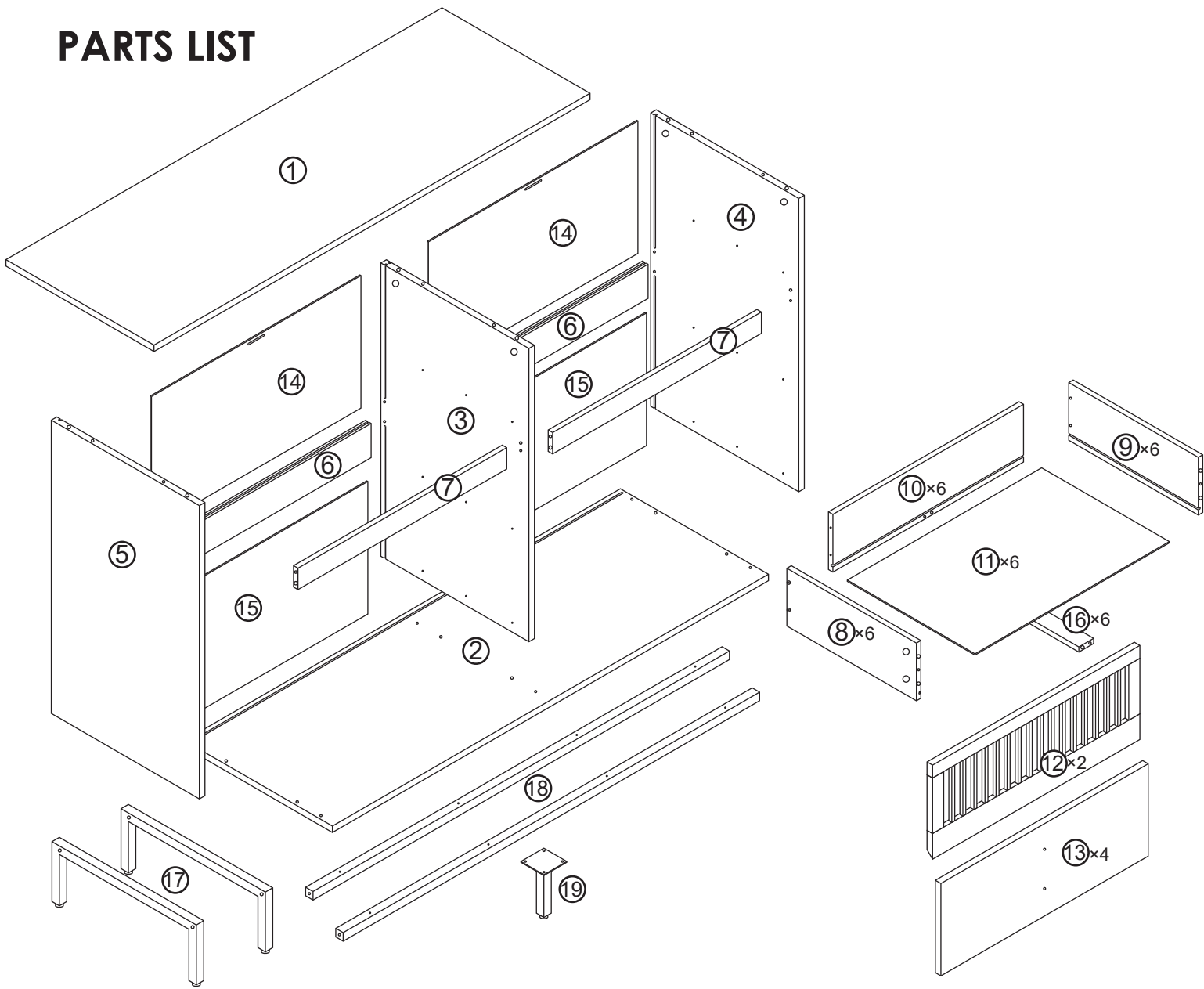



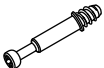





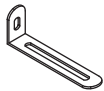

PARTS LIST

<p>① 1175*400</p>  <p style="text-align: right;">x1</p>	<p>② 1175*400</p>  <p style="text-align: right;">x1</p>	<p>③ 686*400</p>  <p style="text-align: right;">x1</p>	<p>④ 686*400</p>  <p style="text-align: right;">x1</p>
<p>⑤ 686*400</p>  <p style="text-align: right;">x1</p>	<p>⑥ 564*80</p>  <p style="text-align: right;">x2</p>	<p>⑦ 564*50</p>  <p style="text-align: right;">x2</p>	<p>⑧ 350*135</p>  <p style="text-align: right;">x6</p>
<p>⑨ 350*135</p>  <p style="text-align: right;">x6</p>	<p>⑩ 515*135</p>  <p style="text-align: right;">x6</p>	<p>⑪ 525*345</p>  <p style="text-align: right;">x6</p>	<p>⑫ 560*220</p>  <p style="text-align: right;">x2</p>
<p>⑬ 560*216</p>  <p style="text-align: right;">x4</p>	<p>⑭ 574*310</p>  <p style="text-align: right;">x2</p>	<p>⑮ 574*310</p>  <p style="text-align: right;">x2</p>	<p>⑯ 40*338</p>  <p style="text-align: right;">x6</p>
<p>⑰ 390*145</p>  <p style="text-align: right;">x2</p>	<p>⑱ 1125*20</p>  <p style="text-align: right;">x2</p>	<p>⑲ 60*145</p>  <p style="text-align: right;">x1</p>	

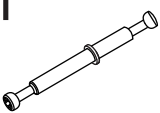
PARTS LIST

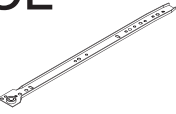
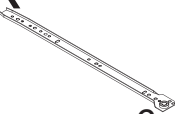
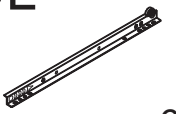

HARDWARES LIST

A 6×35mm  ×48	B 15×10mm  ×54	C 6×30mm  ×40	D 4×35mm  ×32	E 4×12mm  ×60	F 4×18mm  ×8
G  ×4	H 6×12mm  ×4	I 6×30mm  ×12	J 4×12mm  ×2	K  ×2	L  ×2
M  ×3	N 3×14mm  ×16	O  ×16	P  ×24		
CL  ×6	CR  ×6	DL  ×6	DR  ×6		

INSTALLATION STEPS

1

YOU WILL NEED

A x6

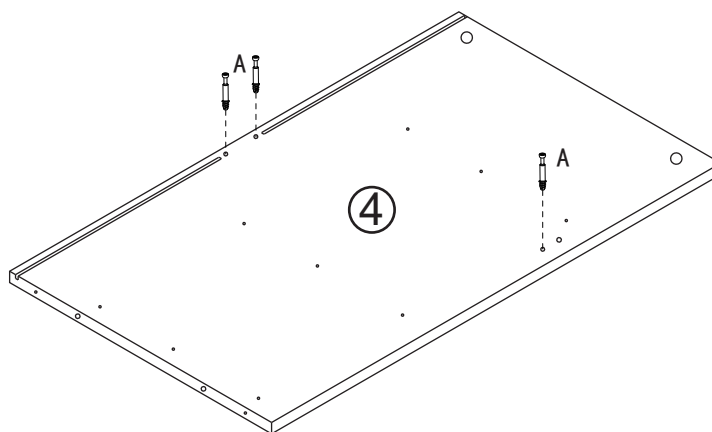
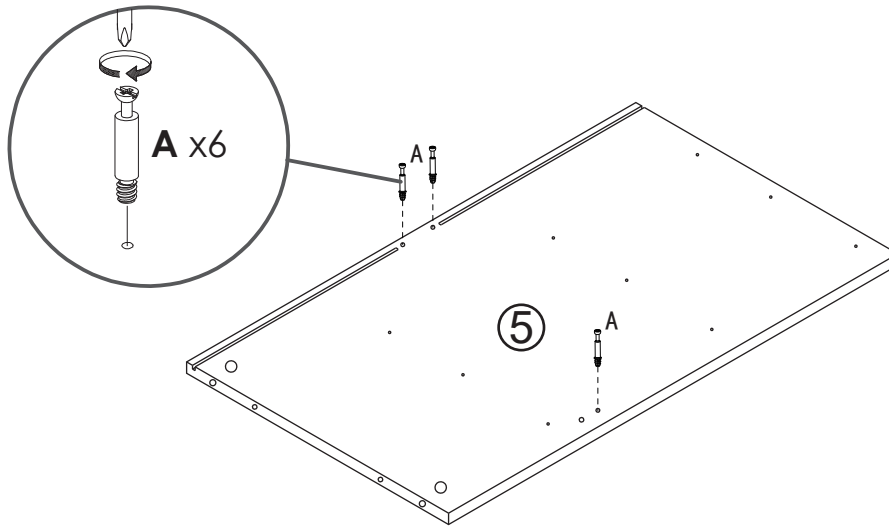

YOU WILL NEED

E x18

CL x3

CR x3

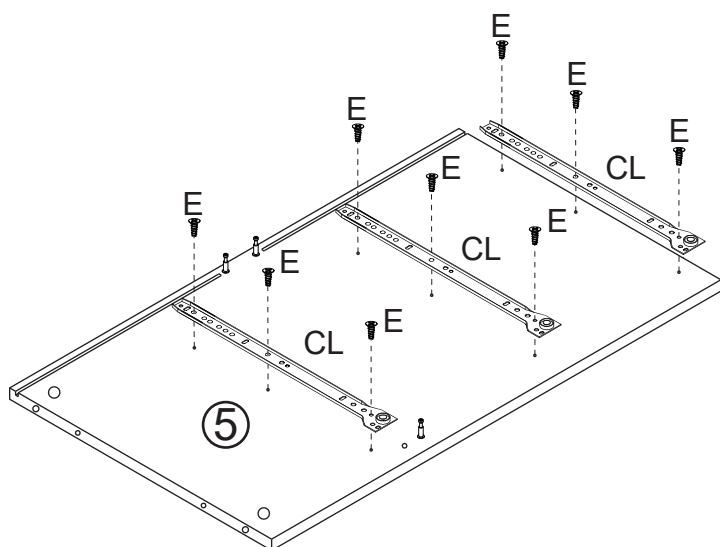
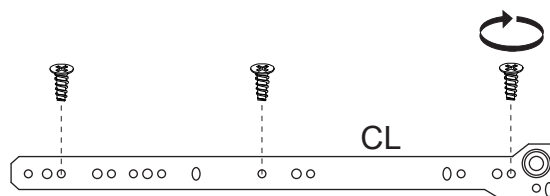
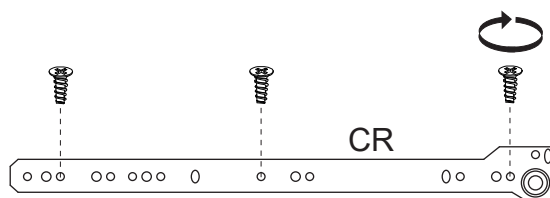
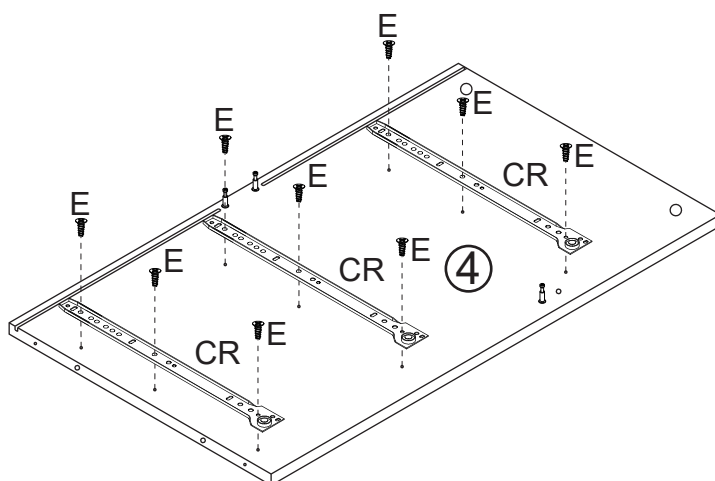

YOU WILL NEED

E x18

CL x3

CR x3

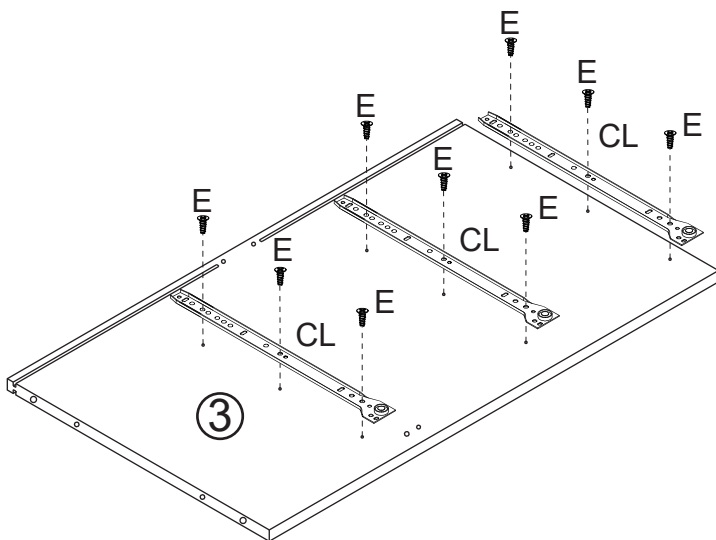
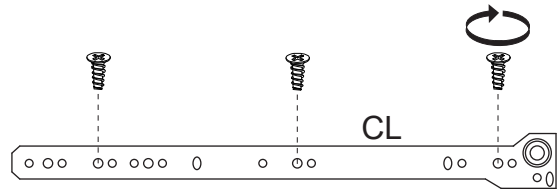
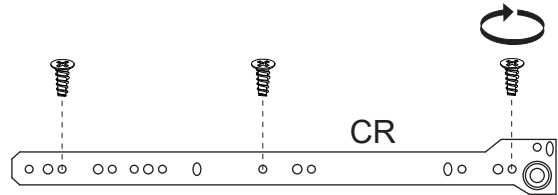
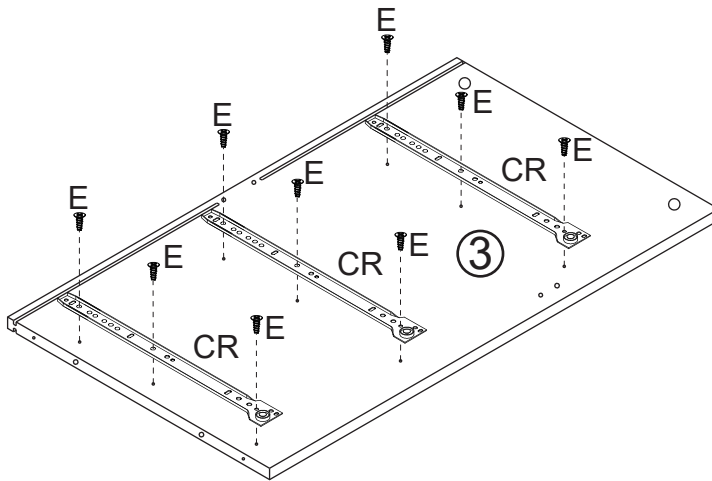

YOU WILL NEED

B x3

C x1

M x3

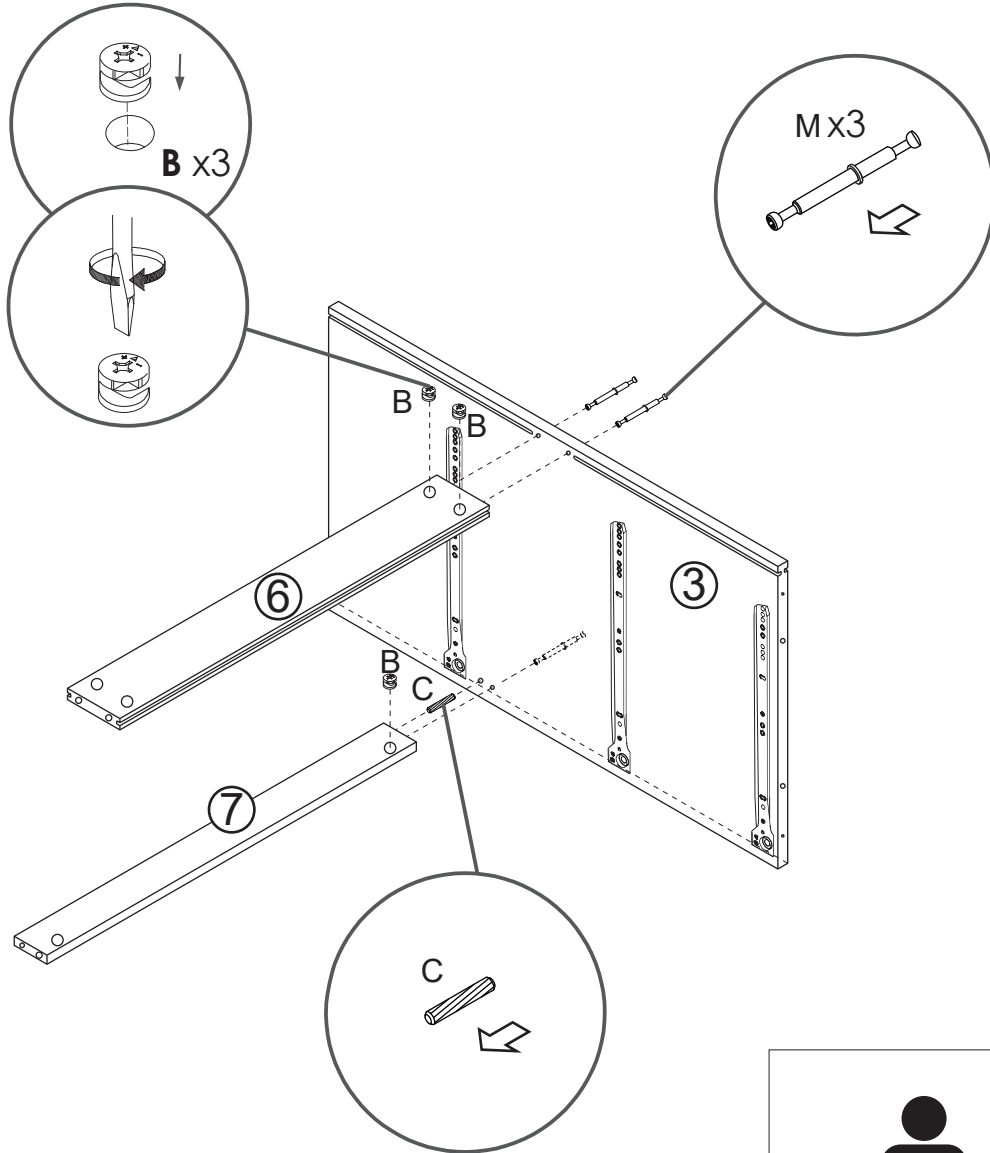

NOTE: This step to be accomplished by two persons

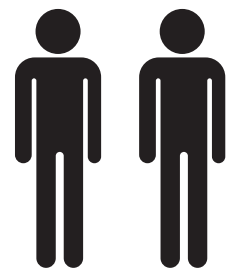
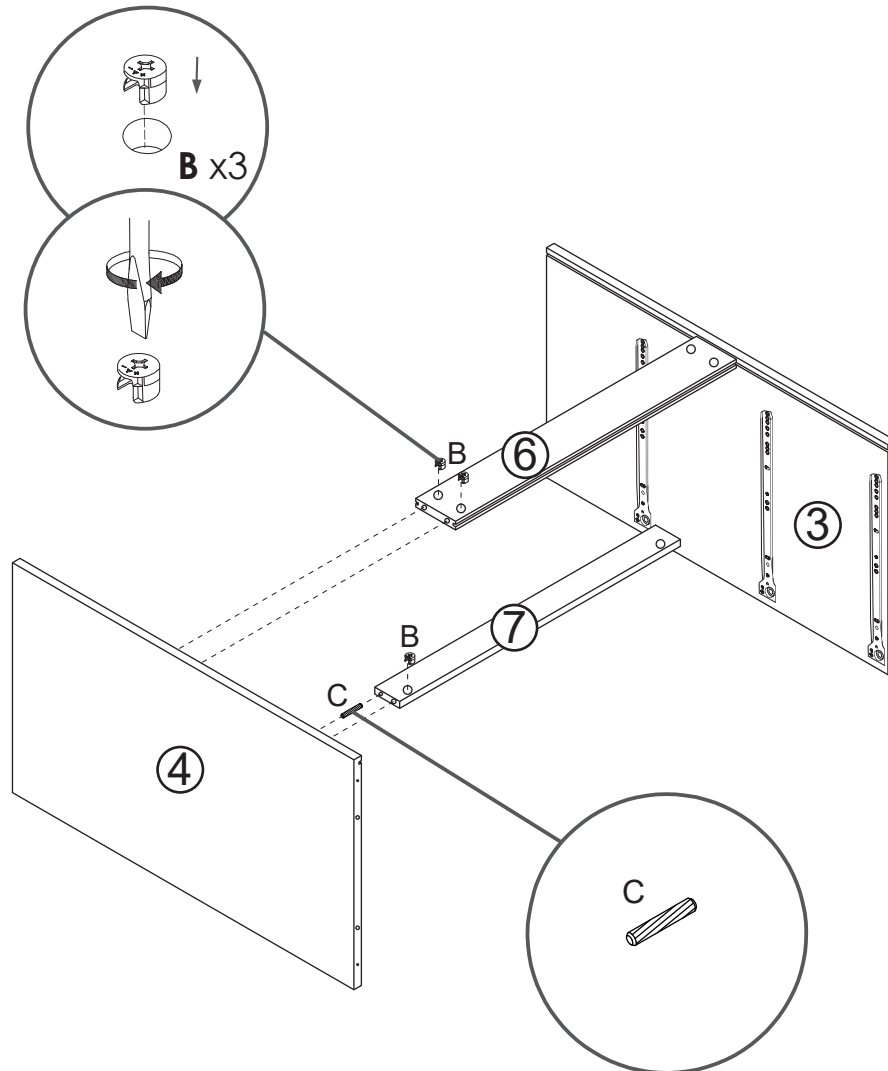

NOTE: This step to be accomplished by two persons

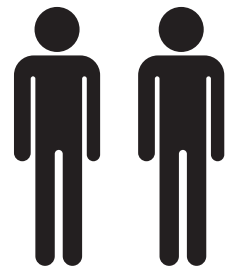
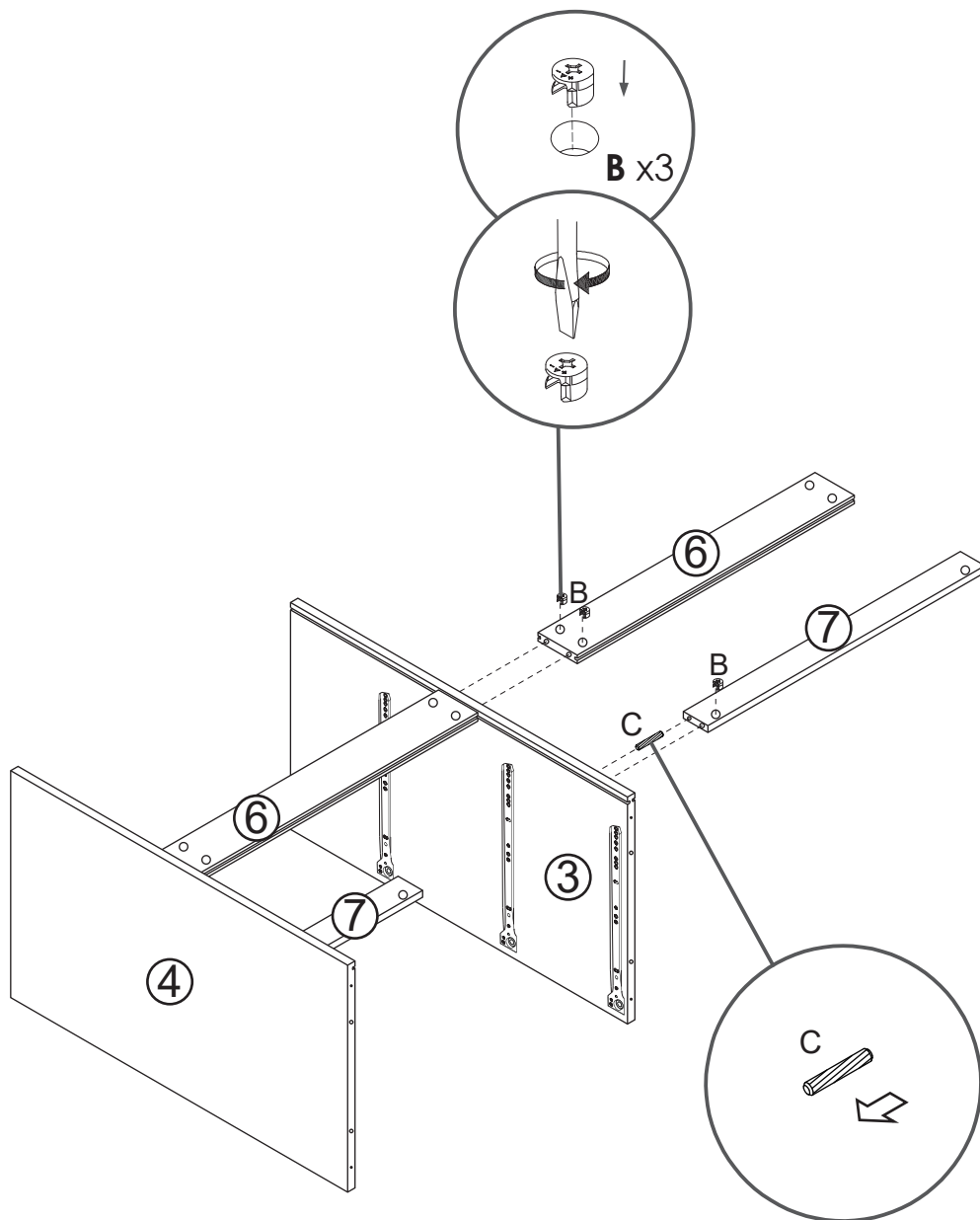

NOTE: This step to be accomplished by two persons

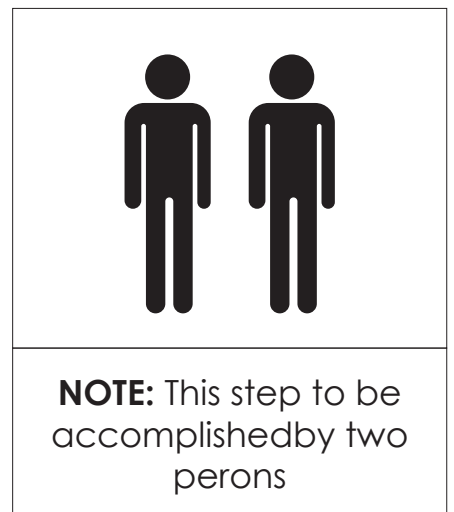
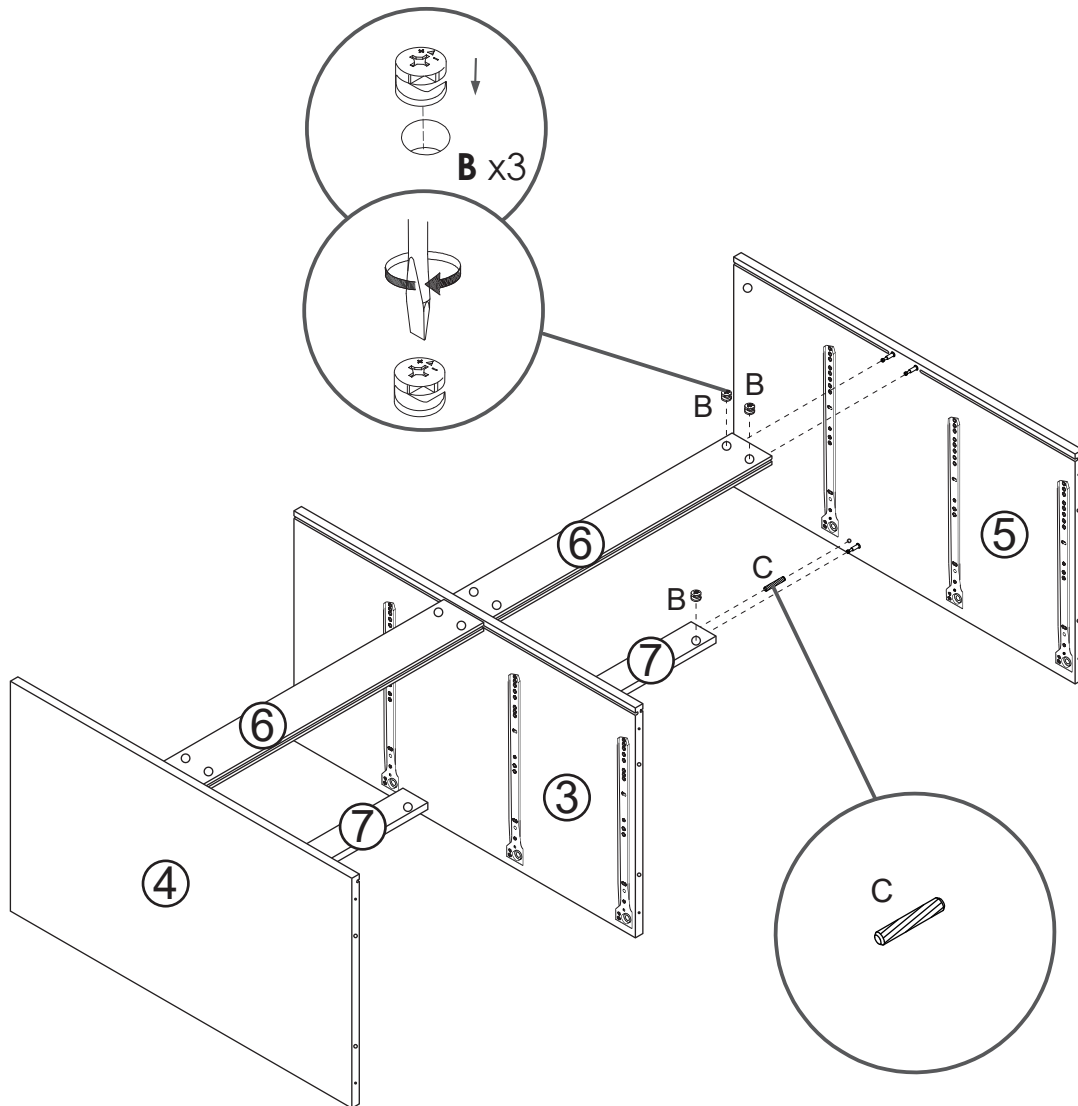

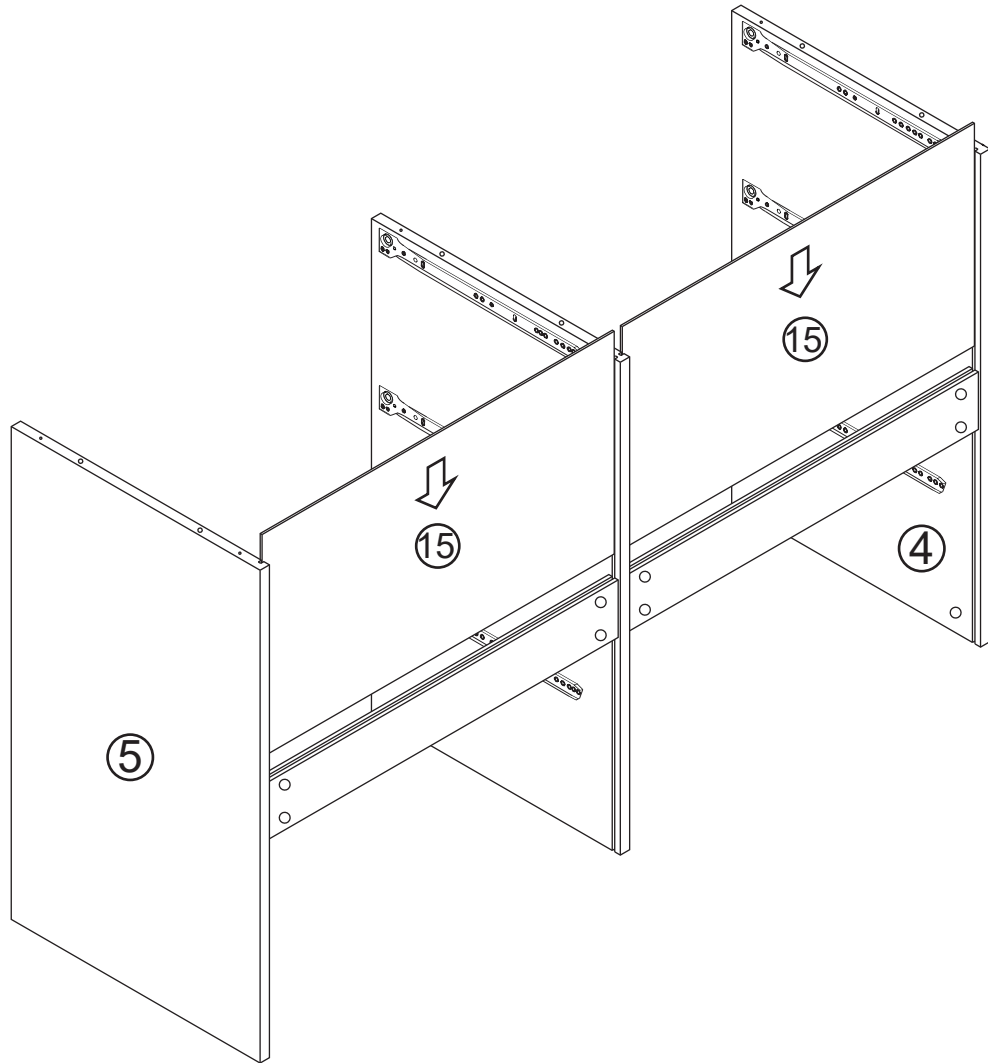

YOU WILL NEED

C x6

D x6

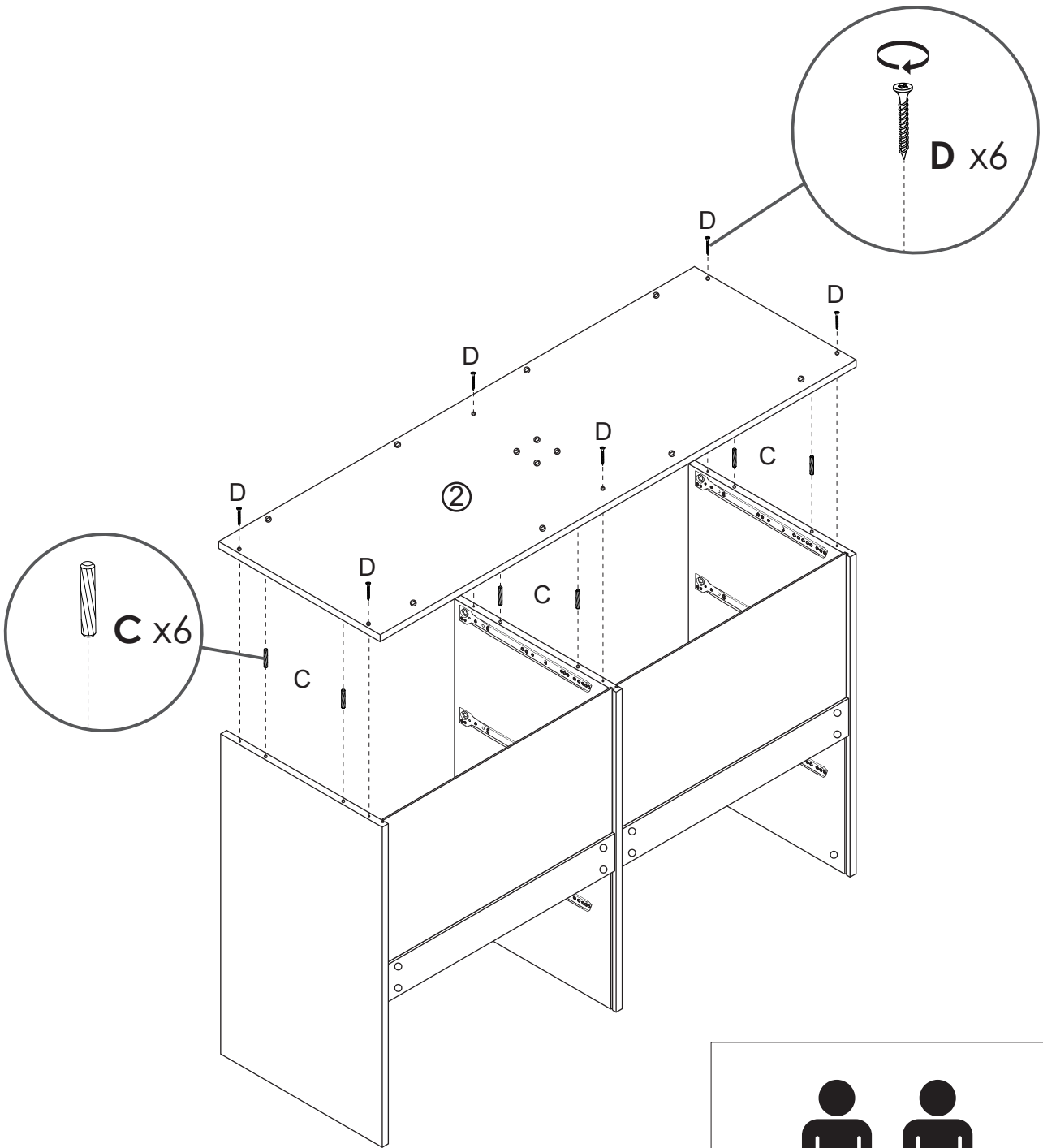

NOTE: This step to be accomplished by two persons

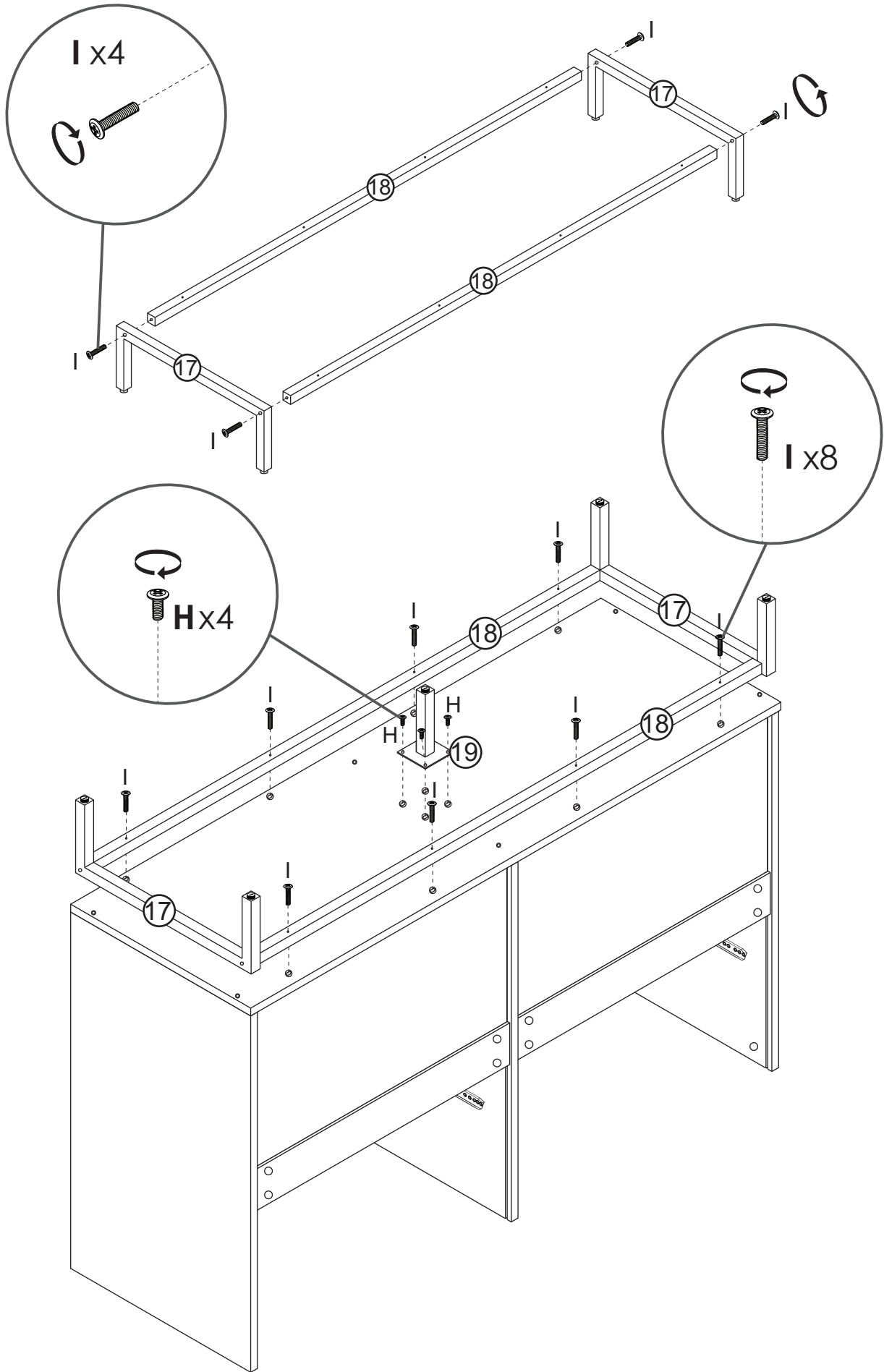

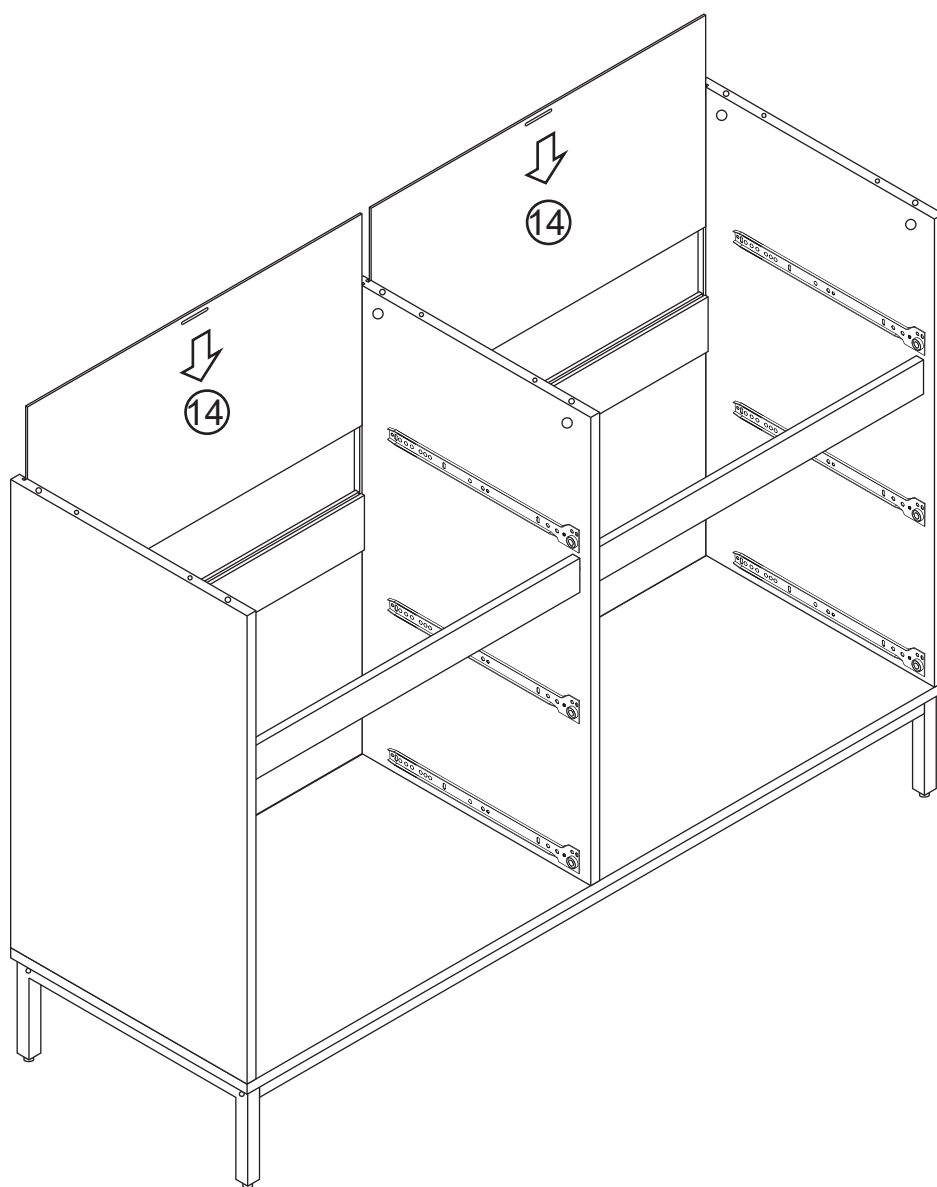

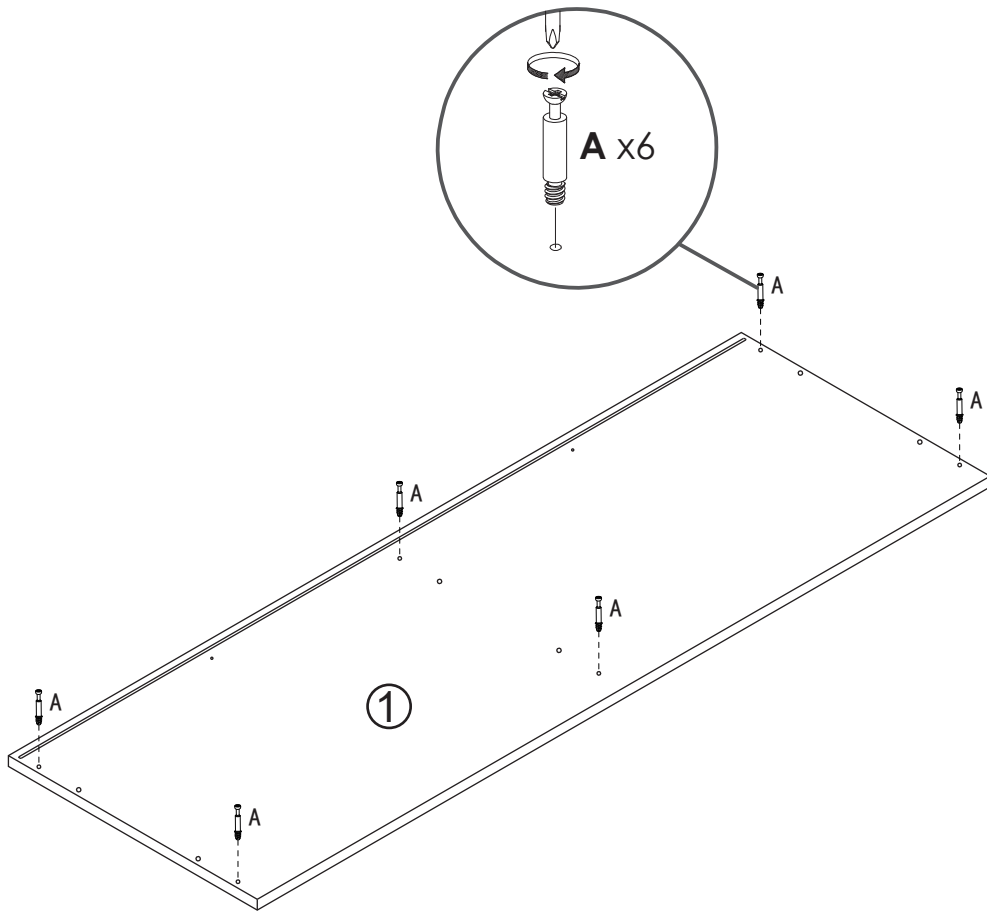

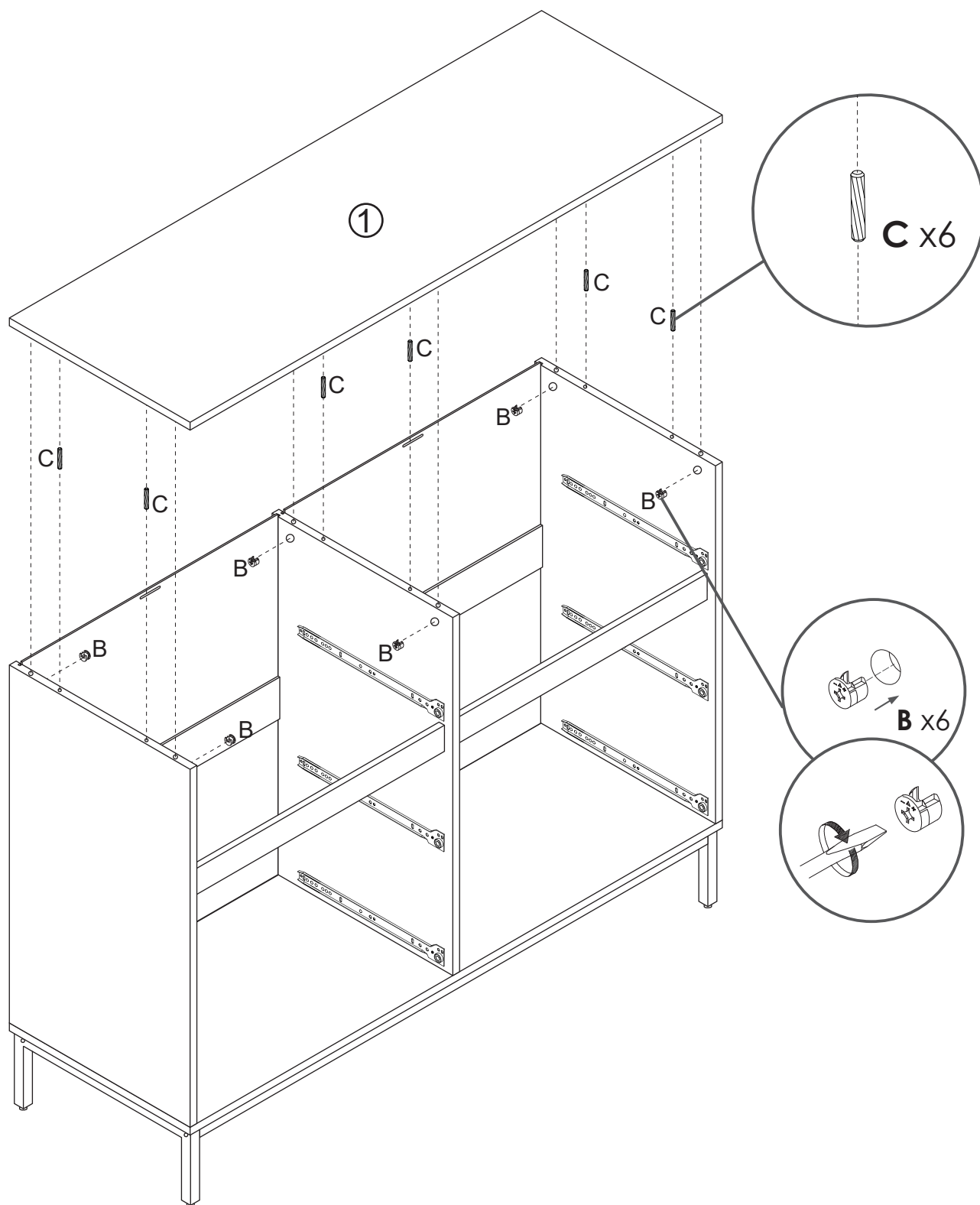

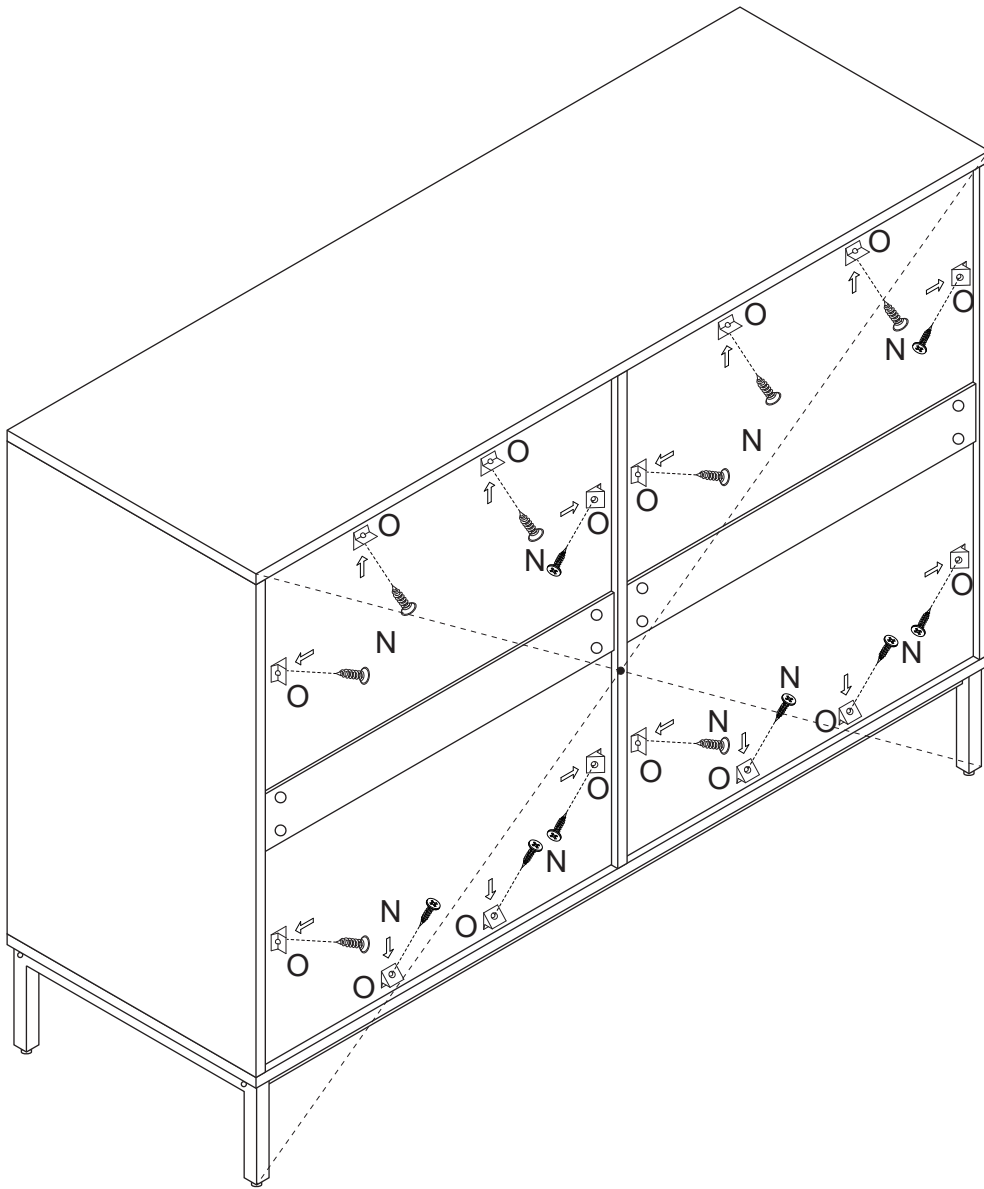

YOU WILL NEED

D x2	J x2	K x2	L x2
------	------	------	------

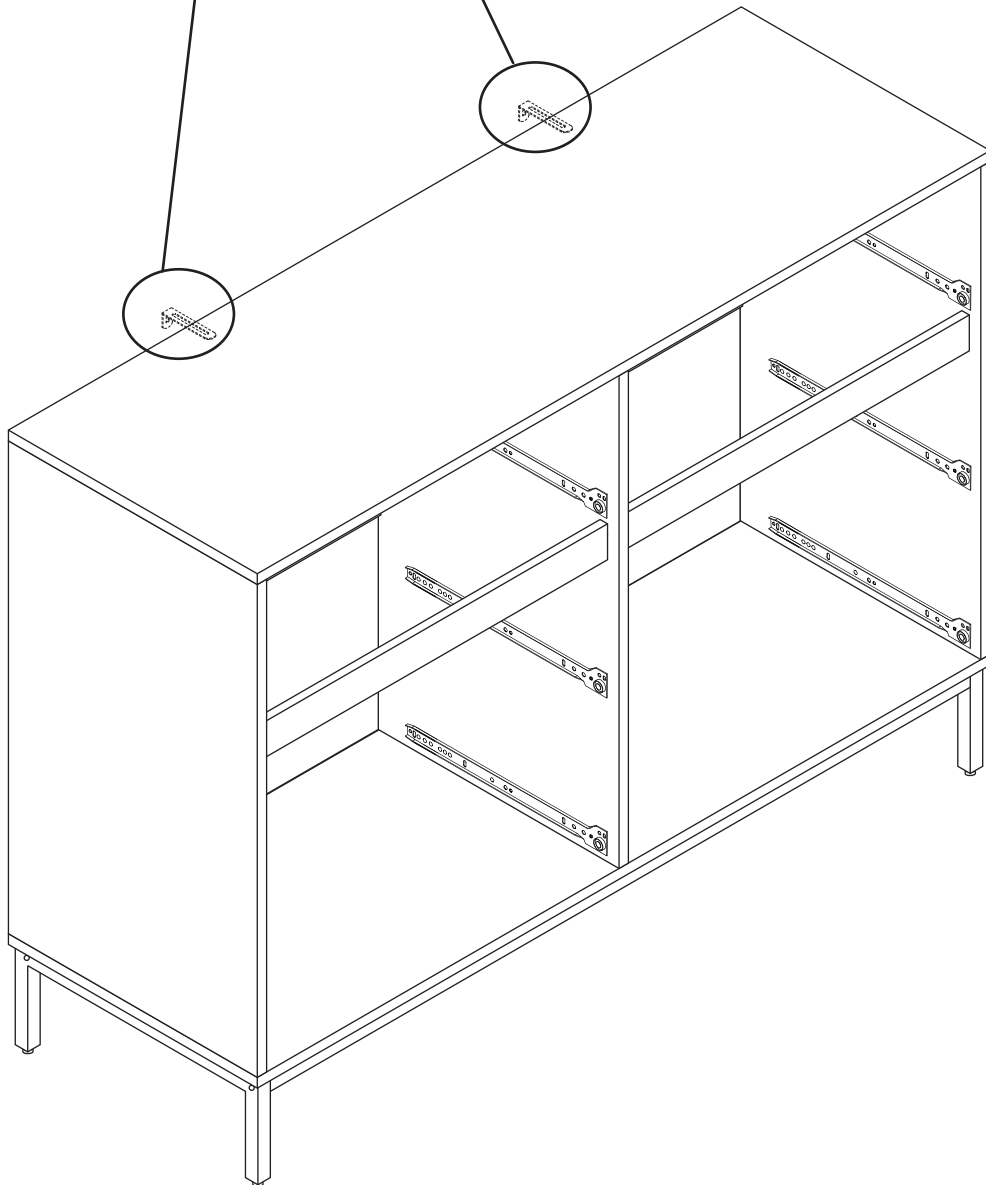
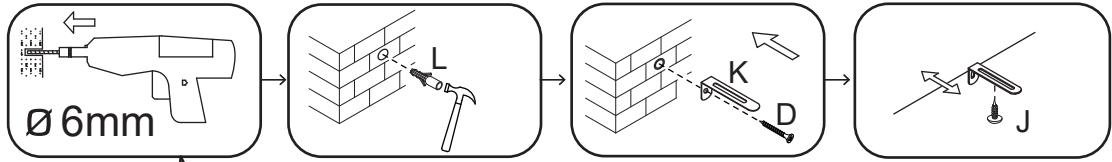

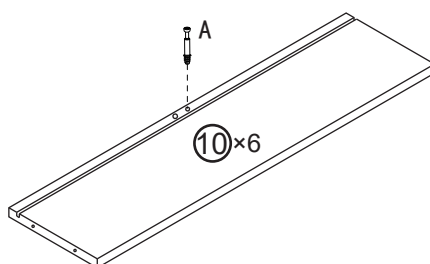
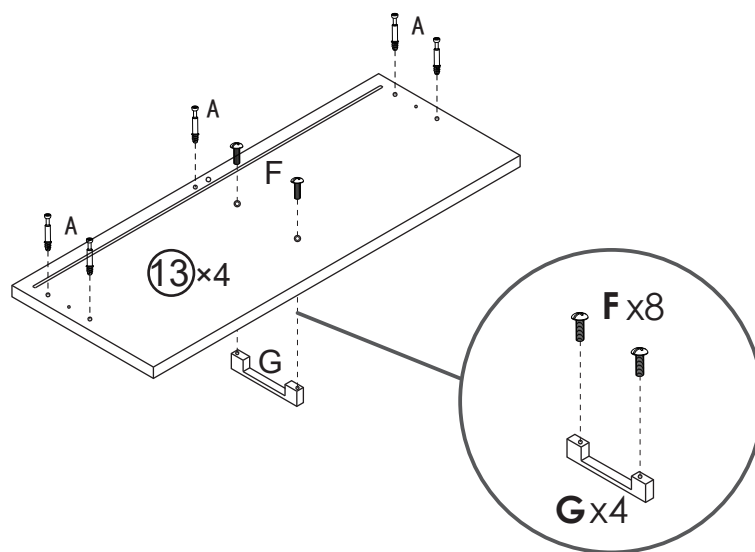
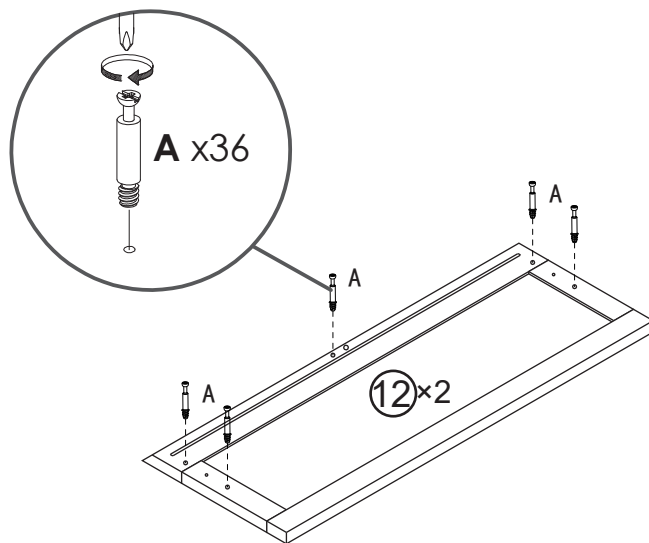

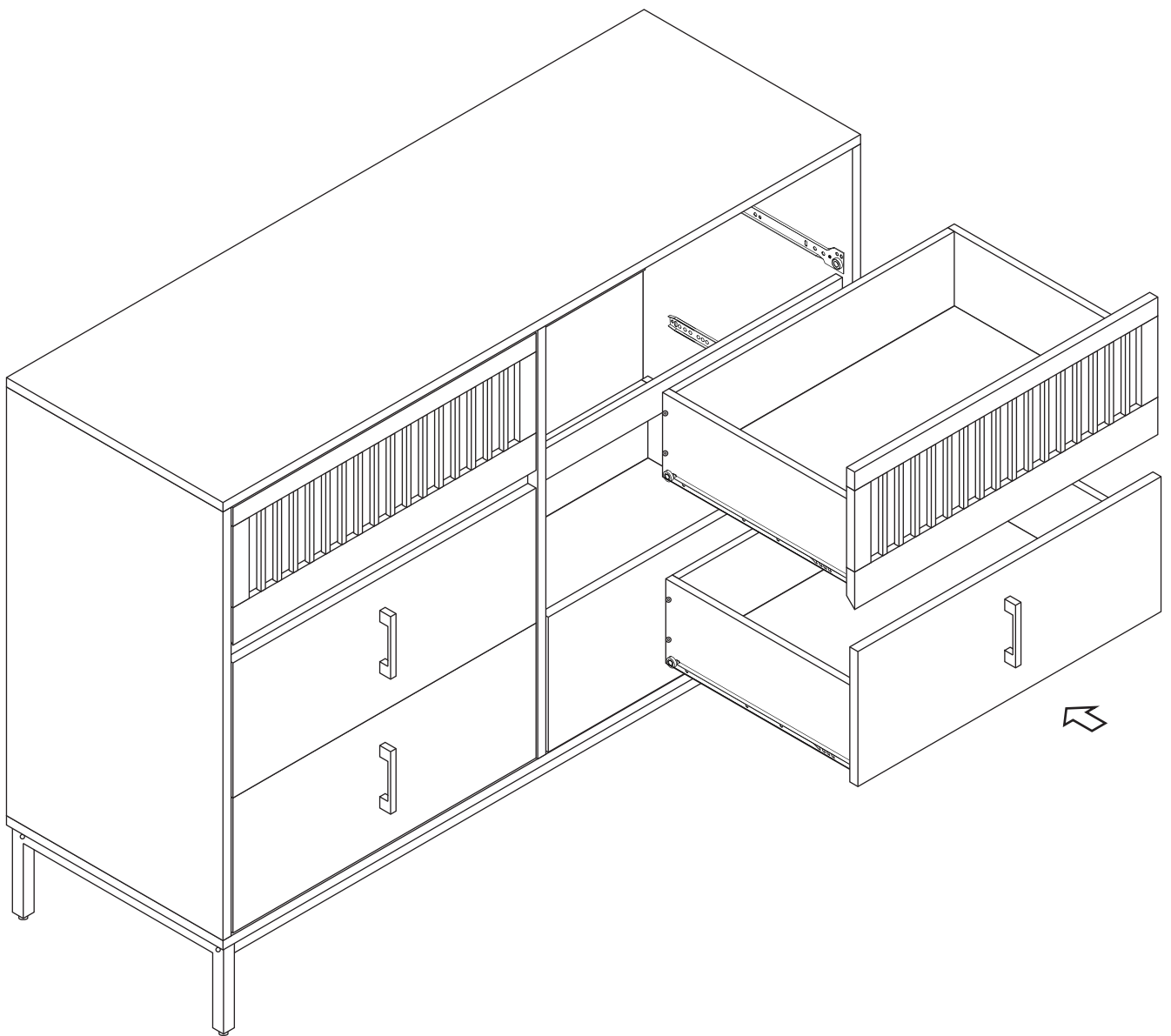
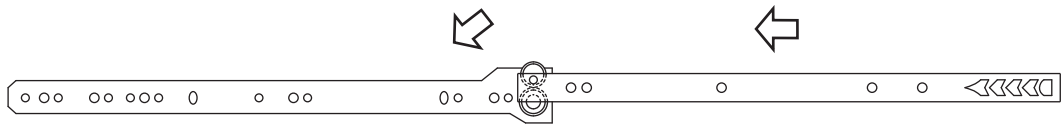

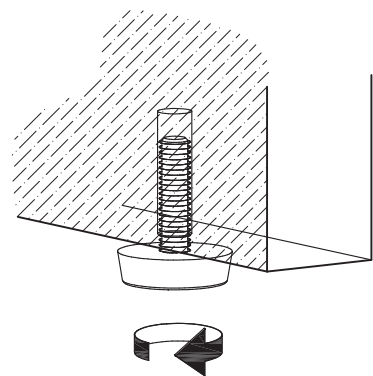
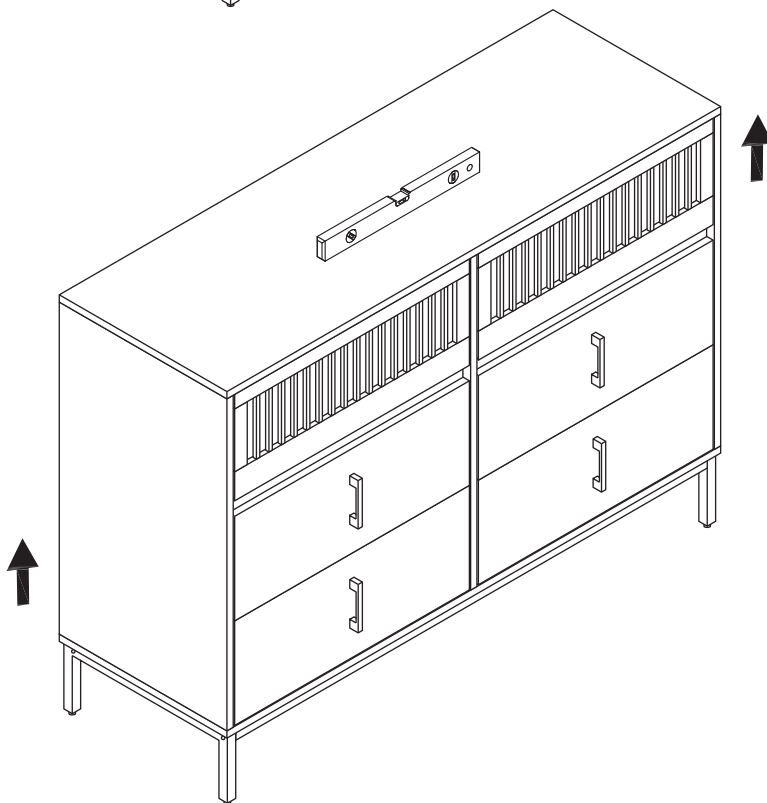
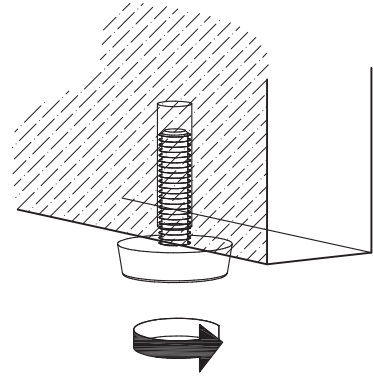
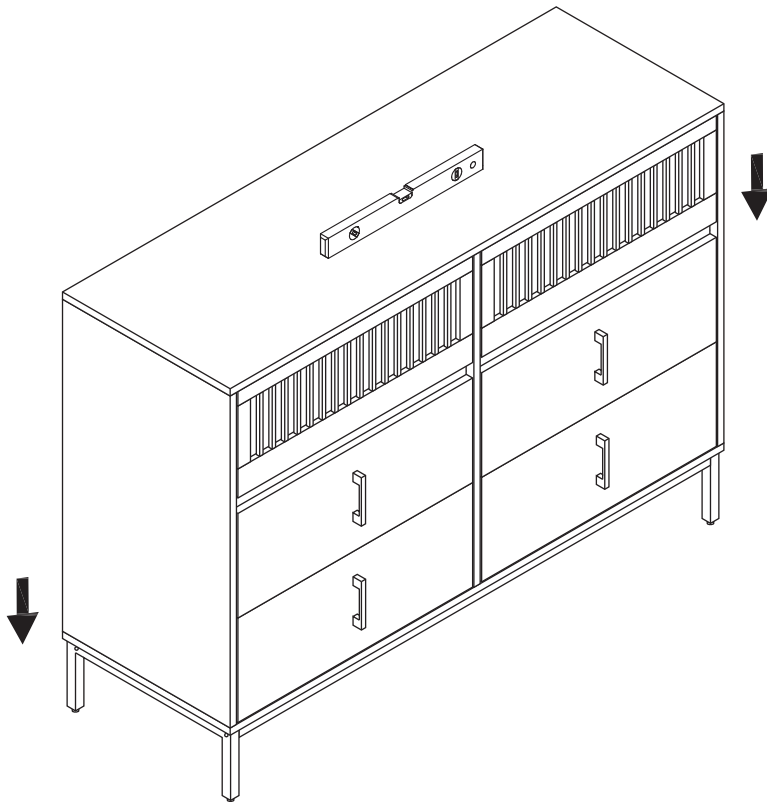

Model: H-016

Made in China

