

Outdoor Kitchen Storage

SKU: LTFA5276

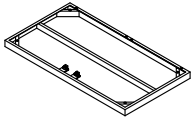

parts and components I



① 1X

Aluminum
Worktop

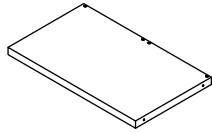

② 1X

Aluminum
Bottom Plate



③ 4X

Bracket

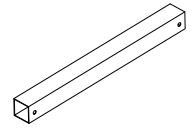

④ 2X

Aluminum
Crosspiece

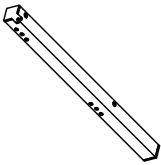

⑤ 1X

Aluminum Leg

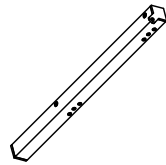

⑥ 1X

Aluminum Leg

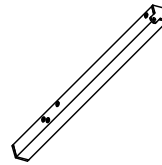

⑦ 1X

Aluminum Leg

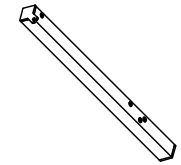

⑧ 1X

Aluminum Leg

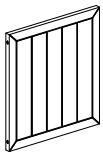

⑨ 2X

Aluminum
Sidewall

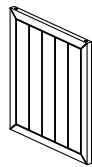

⑩ 2X

Aluminum
Backwall

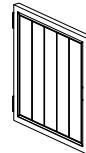

⑪ 1X

Aluminum
Left Door



⑫ 1X

Aluminum
Right Door

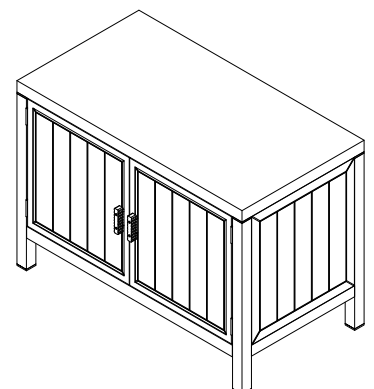

parts and components I

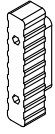

⑬ 2X
Handle

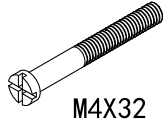

⑭ 4X
M4X32



⑮ 4X
M4



⑯ 12X
M4*12

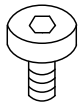

⑰ 28X
M6X15



⑱ 4X
M6X18



⑲ 4X
D6

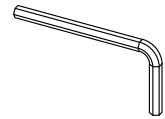

⑳ 1X

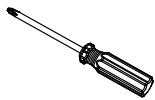

㉑ 1X
Metal Bracket



㉒ 1X
Protective
Cover

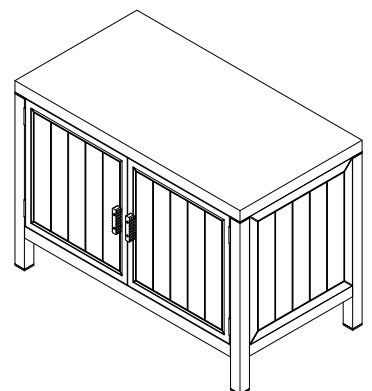

Step 1



⑤ 1X

Aluminum Leg



⑥ 1X

Aluminum Leg



⑦ 1X

Aluminum Leg



⑧ 1X

Aluminum Leg



③ 4X

Bracket



M6X15

⑰ 8X



⑳ 1X

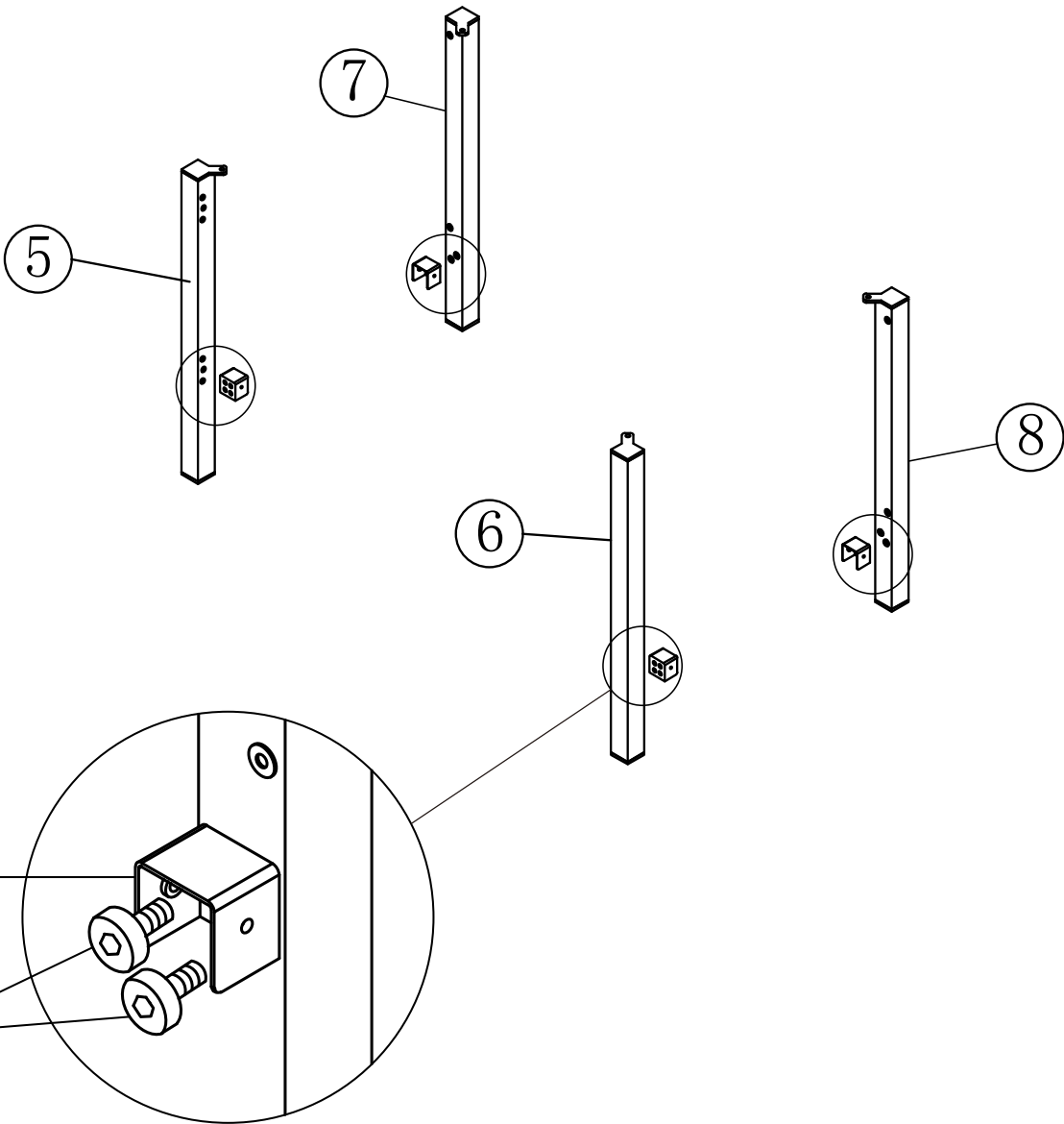

Step 2

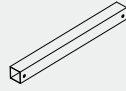

④ 2X

Aluminum Crosspiece

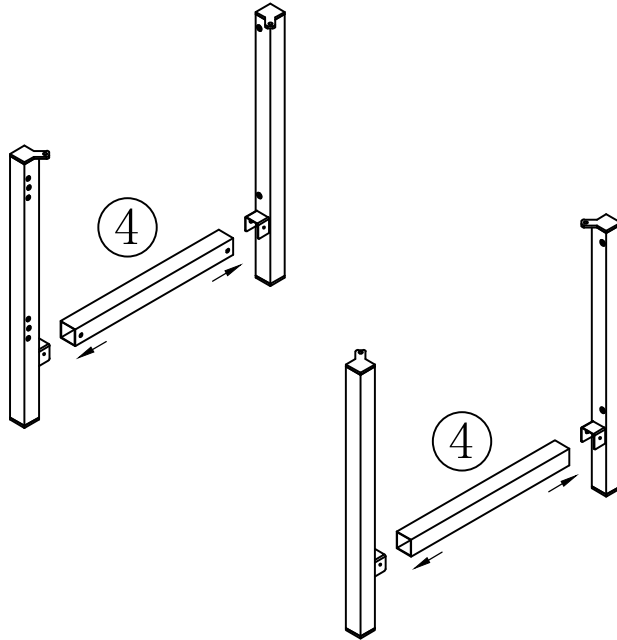

Step 3



⑨ 2X

Aluminum Sidewall



M6X15

⑰ 8X

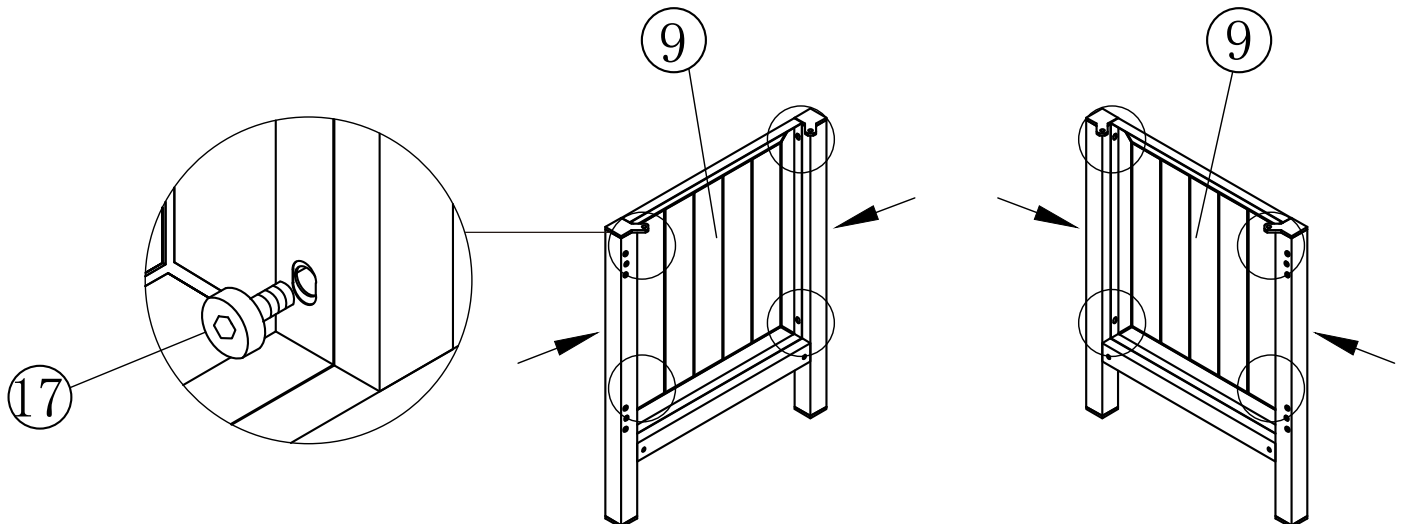

Step 4

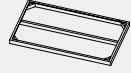

② 1X
Aluminum Worktop



M6X18
⑱ 4X



D6
⑲ 4X

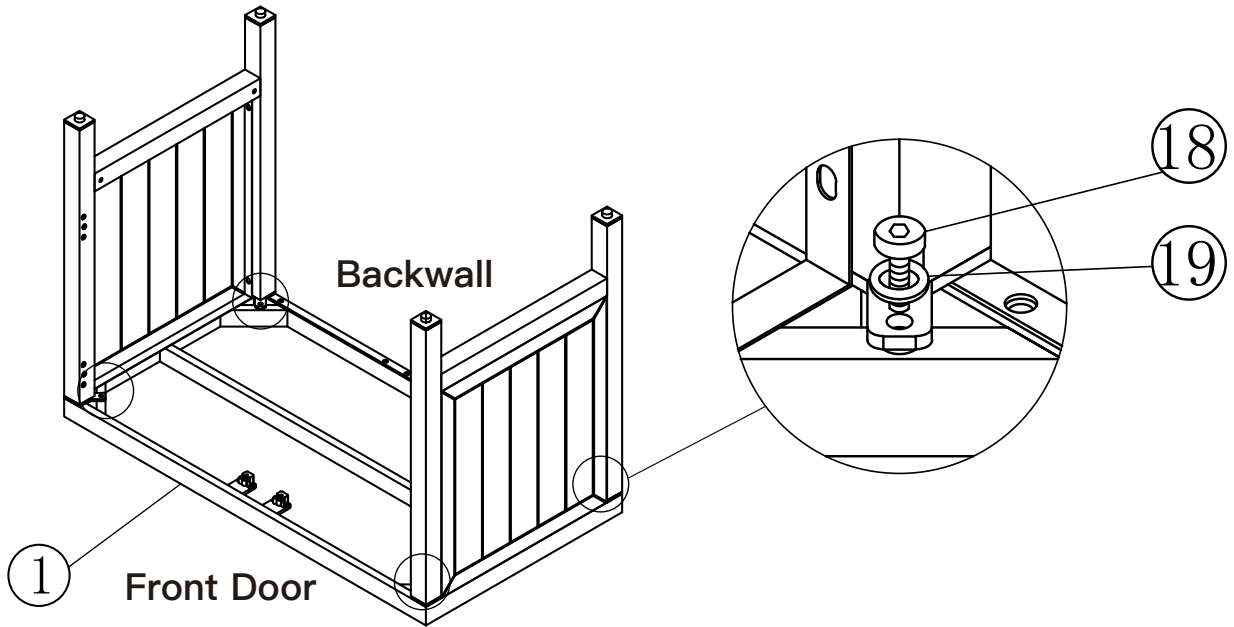

Step 5

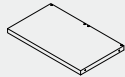

② 1X
Aluminum Bottom Plate



M6X15
⑰ 4X

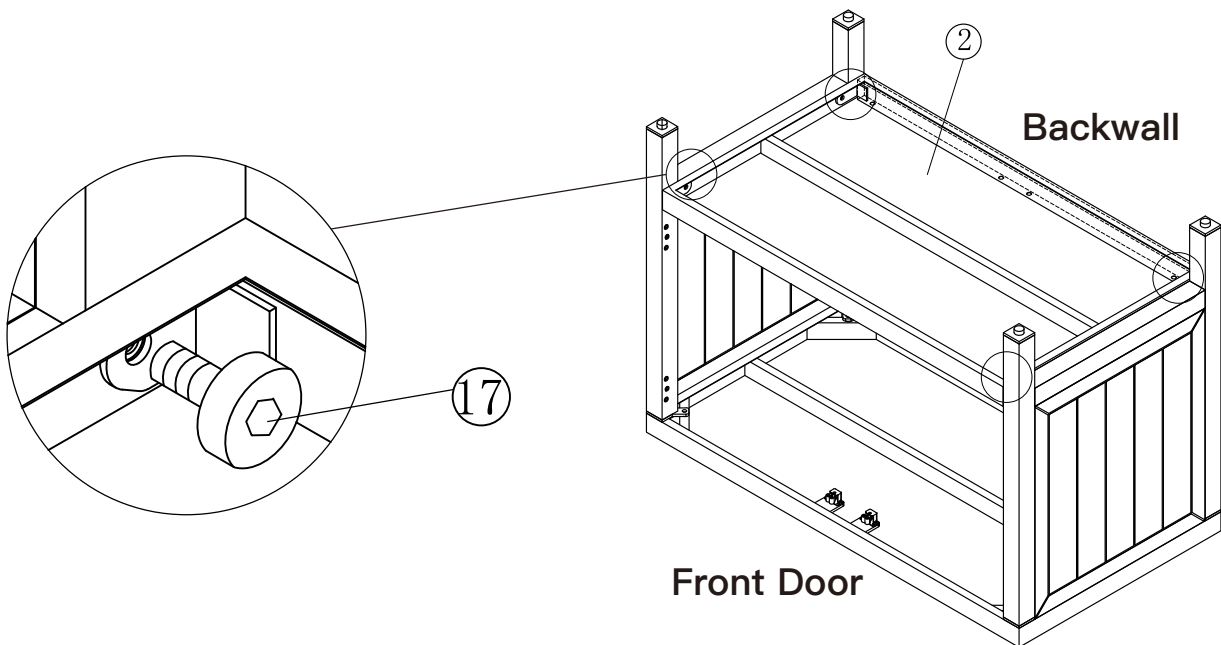

Step 6



⑩ 2X

Aluminum Backwall



M6X15

⑰ 8X

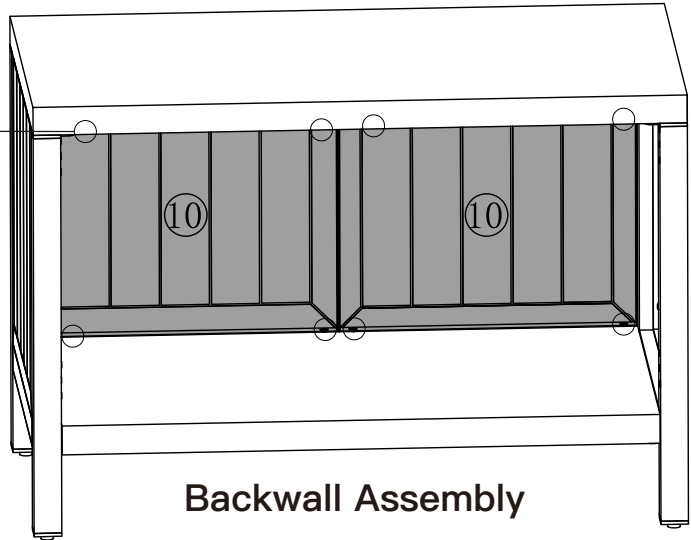
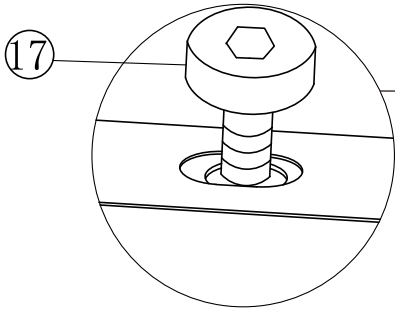

Backwall Assembly

Step 7



⑪ 1X

Aluminum Left Door



⑬ 1X

Handle

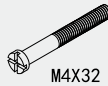

M4X32

⑭ 2X



M4

⑮ 2X



⑰ 1X

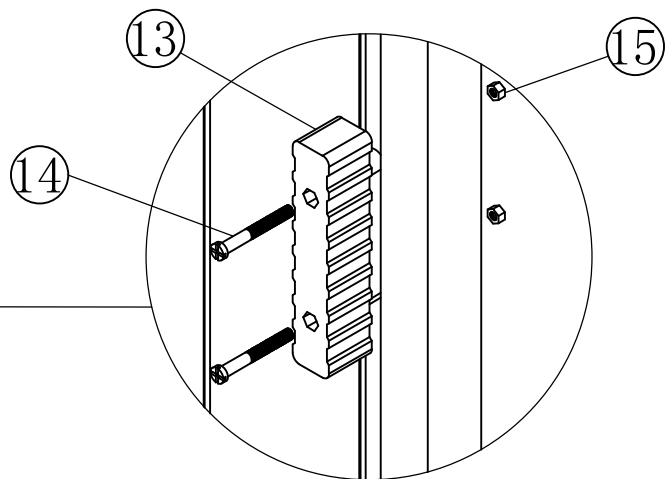
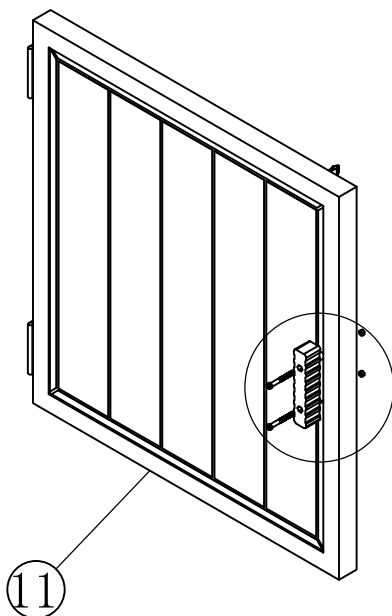

Step 8



⑫ 1X

Aluminum Right Door



⑬ 1X

Handle

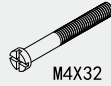

M4X32

⑭ 2X



M4

⑮ 2X

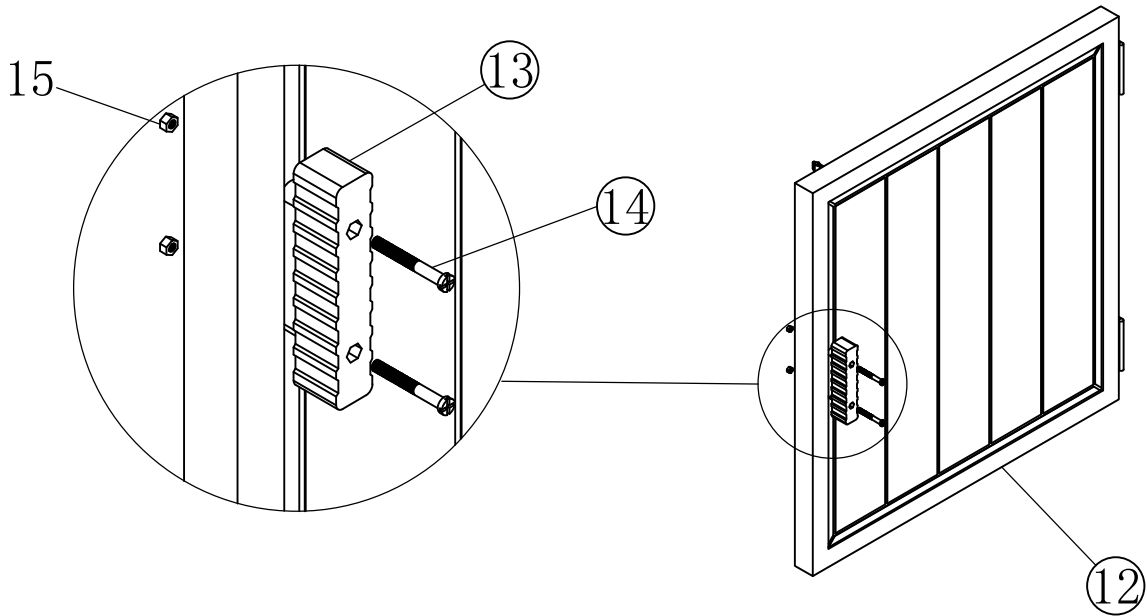

Step 9



⑪ 1X

Aluminum Left Door



⑫ 1X

Aluminum Right Door



M4*12

⑯ 12X

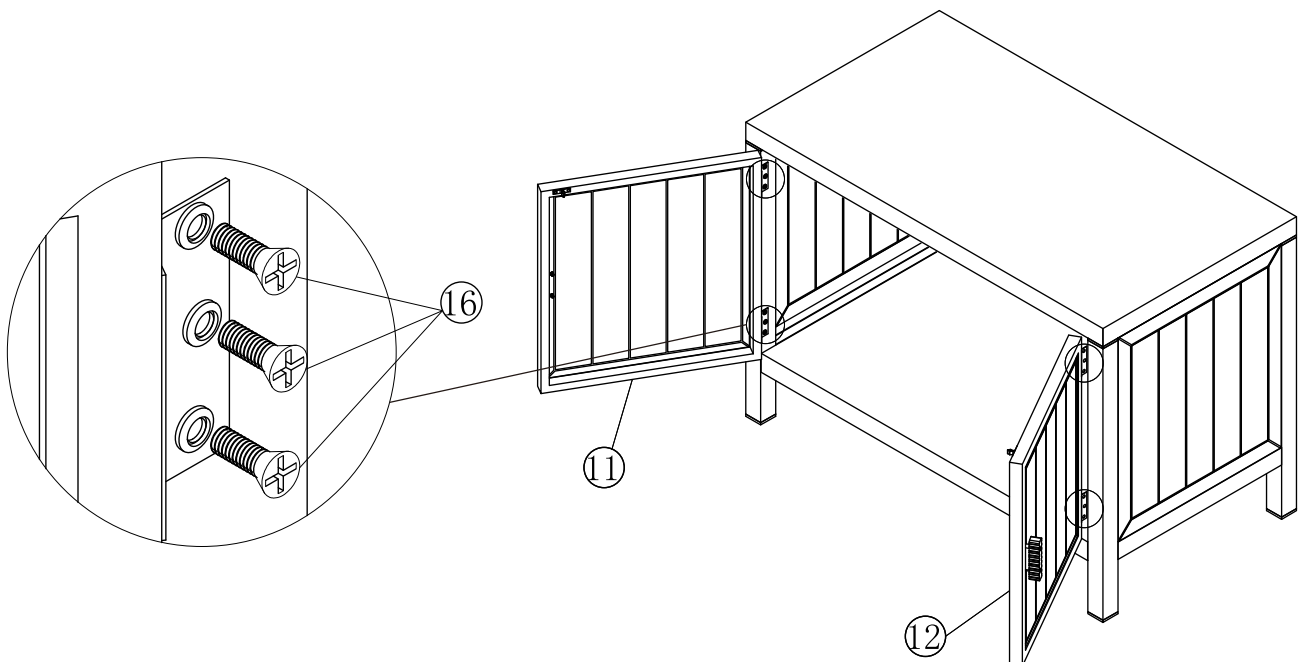

Step 10

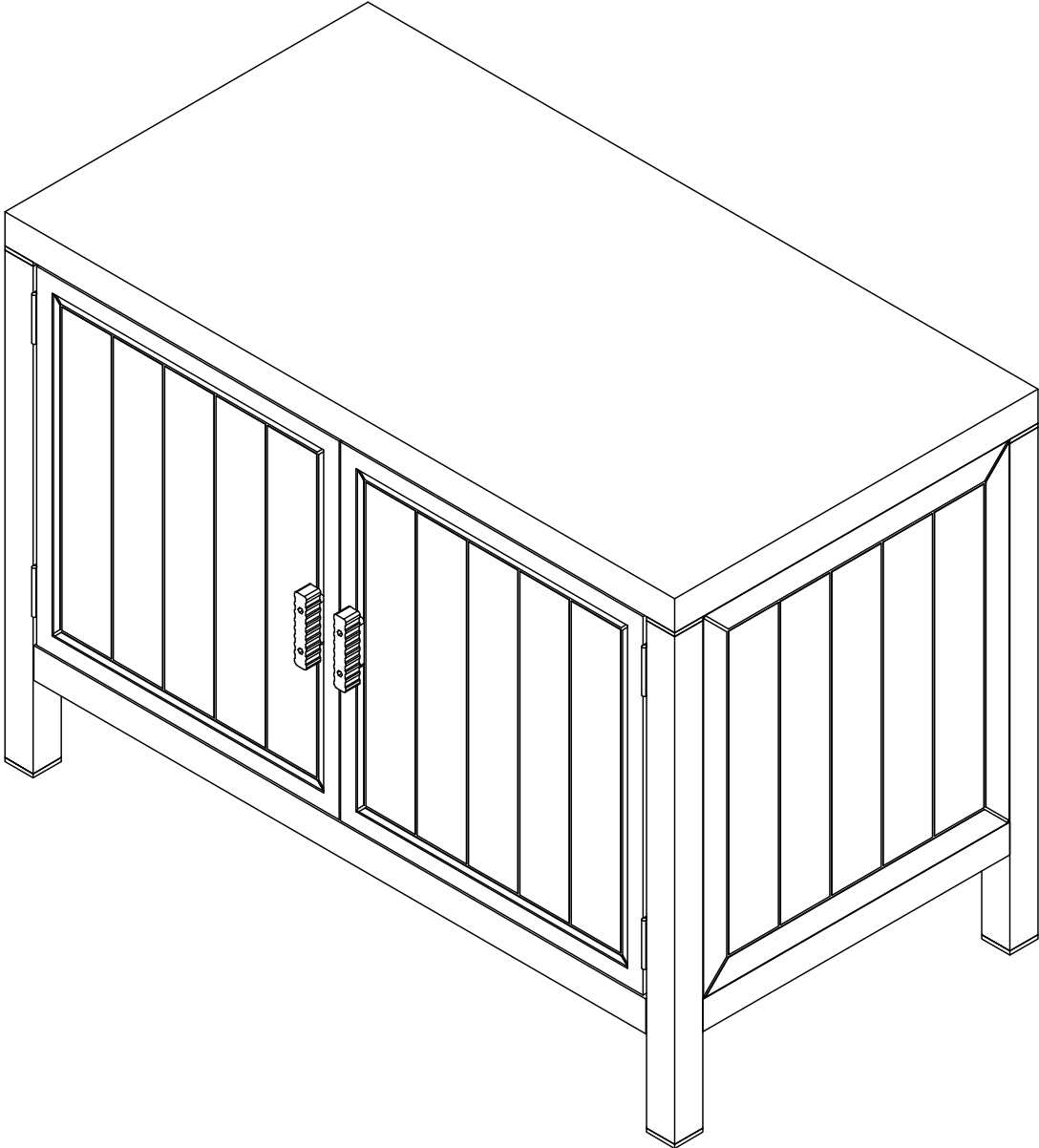

about the outdoor kitchen series

We created the Outdoor Kitchen line because we want everyone to enjoy the outdoors! All outdoor kitchen lines are modular in design, fit together seamlessly and are made of sturdy, durable aluminum countertops for easy connection. Like all domi outdoor products, the Outdoor Kitchen series has stood the test of time and will become a product that consumers trust.



Missing part? Damaged? Contact us via email at
service@domioutdoorliving.com

www.domioutdoorliving.com

Series products



22 1X

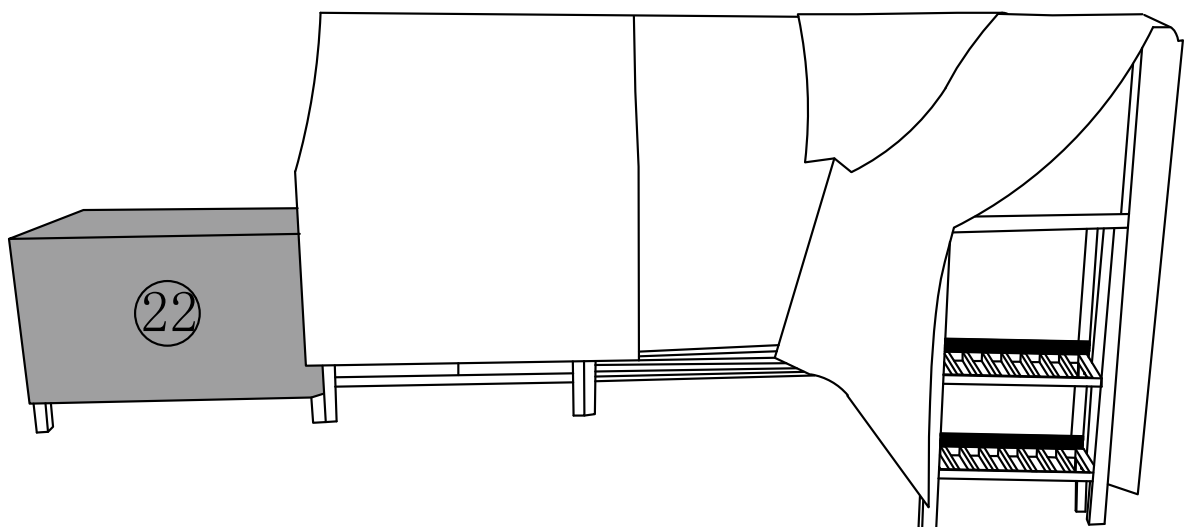
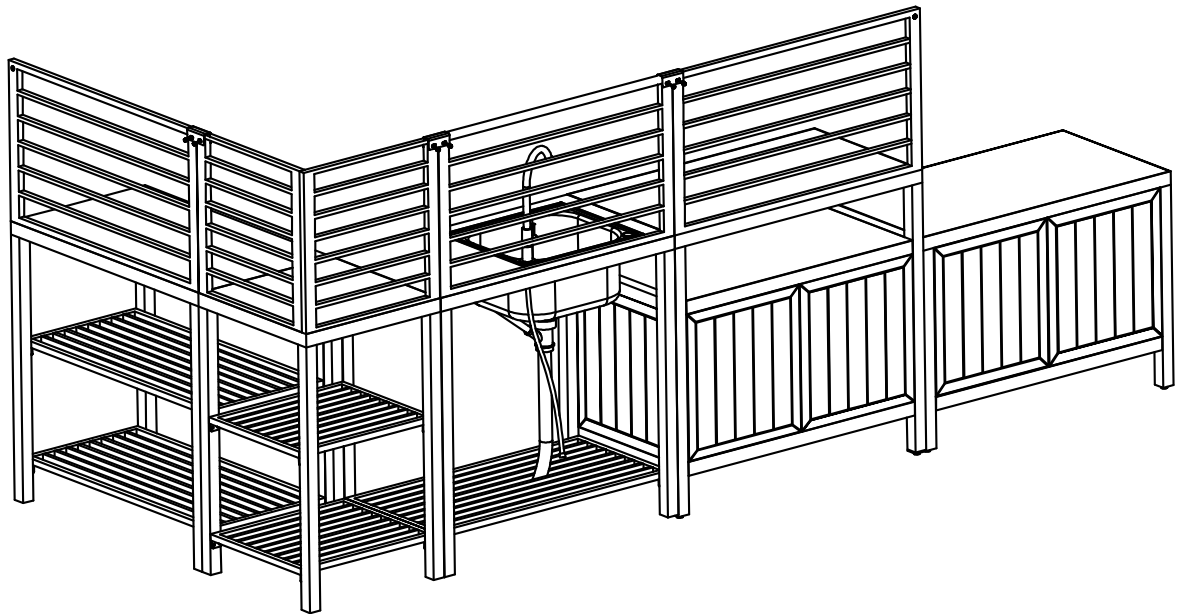

about the outdoor kitchen series

We created the Outdoor Kitchen line because we want everyone to enjoy the outdoors! All outdoor kitchen lines are modular in design, fit together seamlessly and are made of sturdy, durable aluminum countertops for easy connection. Like all domi outdoor products, the Outdoor Kitchen series has stood the test of time and will become a product that consumers trust.



Missing part? Damaged? Contact us via email at service@domioutdoorliving.com

www.domioutdoorliving.com
