

ASSEMBLY INSTRUCTION

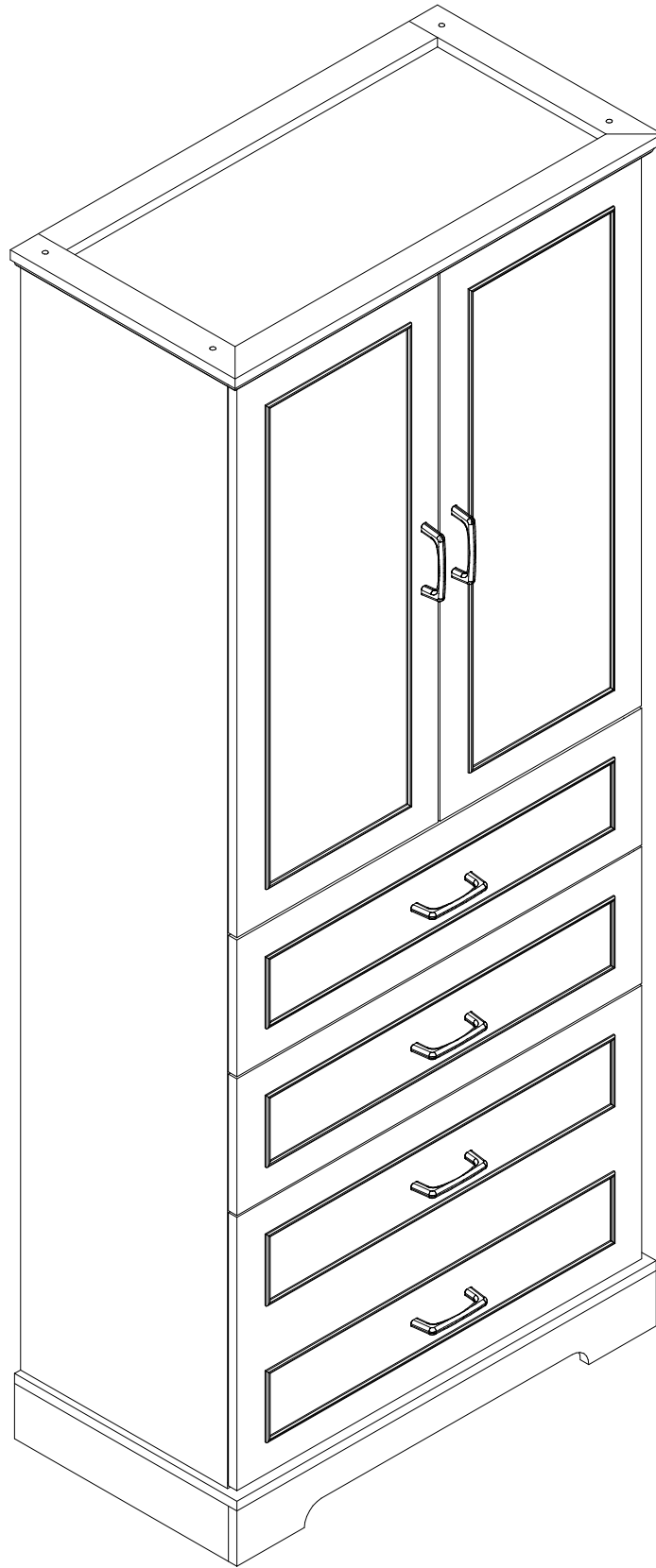

1

ASSEMBLY INSTRUCTION

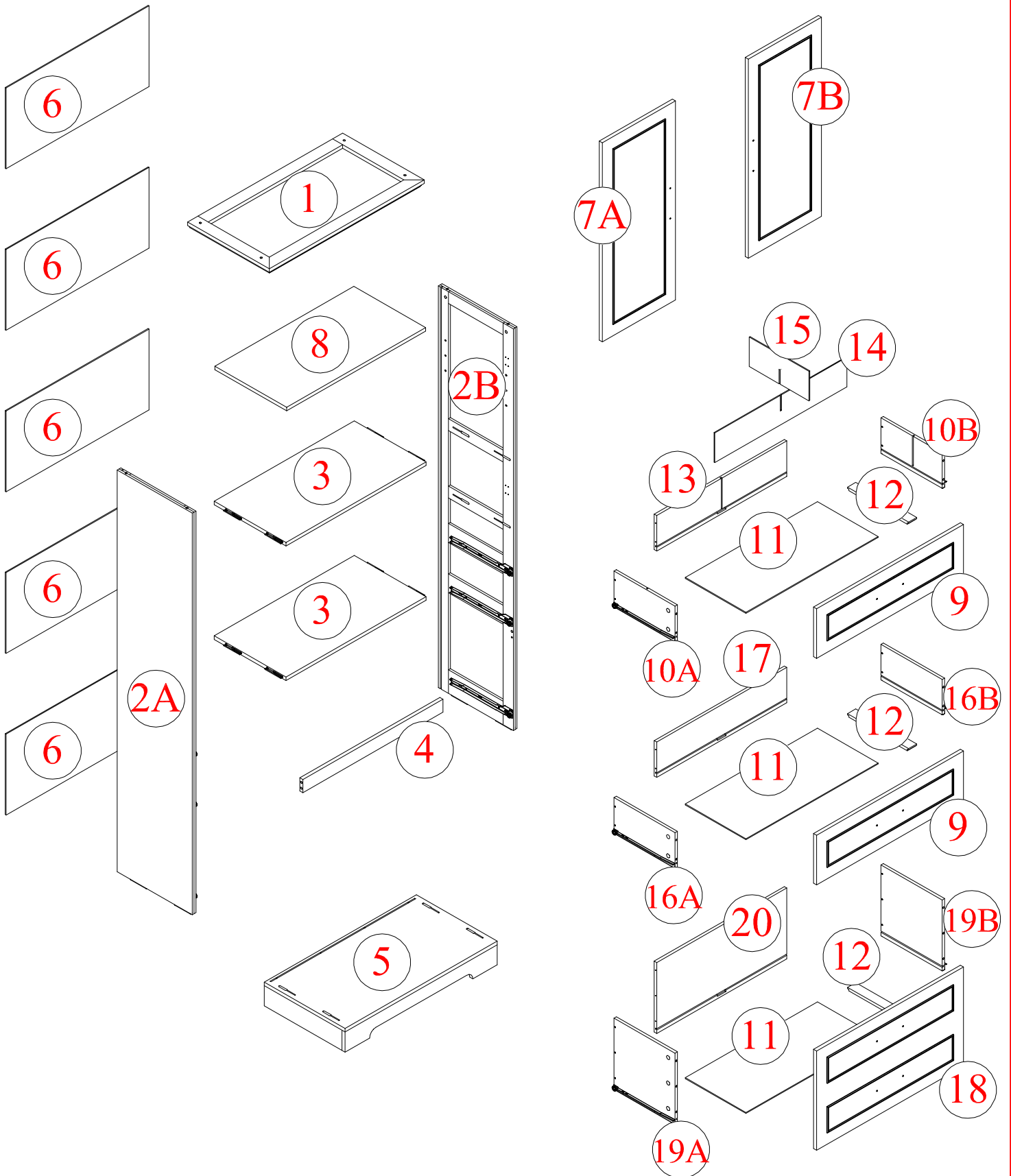

Part List

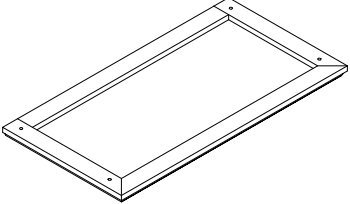
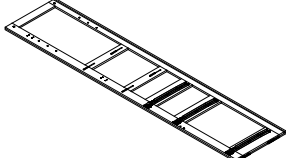
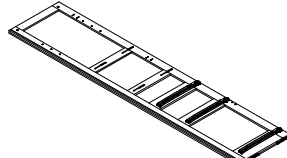
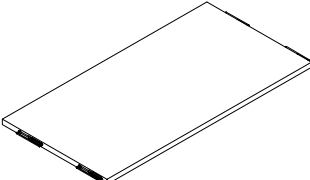
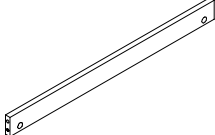
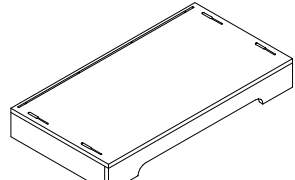
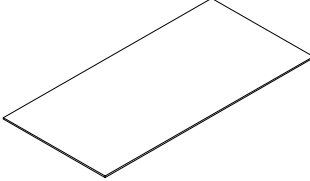
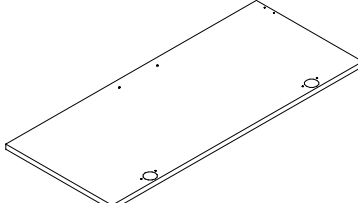
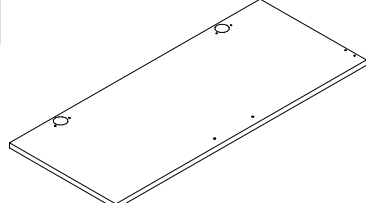
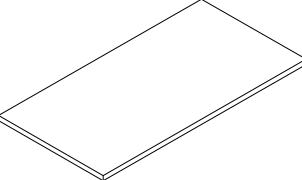
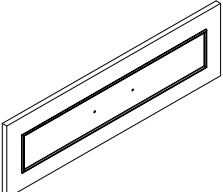
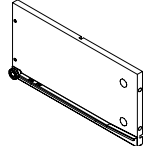
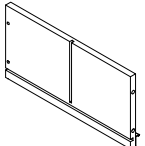
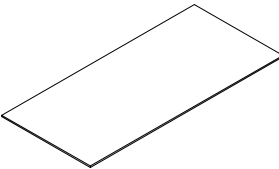
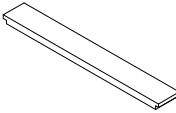
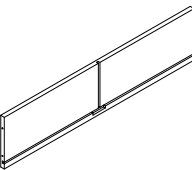
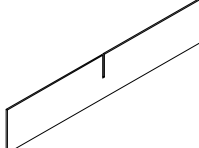
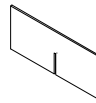
<p>1</p>  <p>The Top Of The Cabinet - 1 pc</p>	<p>2A</p>  <p>Side Edge Of Cabinet - 1 pc</p>	<p>2B</p>  <p>Side Edge Of Cabinet - 1 pc</p>
<p>3</p>  <p>Fixed Shelf - 2 pcs</p>	<p>4</p>  <p>Cross Bar - 1 pc</p>	<p>5</p>  <p>Cabinet Bottom - 1 pc</p>
<p>6</p>  <p>Cabinet Back Panels - 5 pcs</p>	<p>7A</p>  <p>Left Cabinet Door - 1 pc</p>	<p>7B</p>  <p>Right Cabinet Door - 1 pc</p>
<p>8</p>  <p>Adjustable Shelf - 1 pc</p>	<p>9</p>  <p>Drawer- Front Panels - 2 pcs</p>	<p>10A</p>  <p>Drawer - Left Side Panel - 1 pc</p>
<p>10B</p>  <p>Drawer - Right Side Panel - 1 pc</p>	<p>11</p>  <p>Drawer - Bottom Panels - 3 pcs</p>	<p>12</p>  <p>Drawer - Support Bar - 3 pcs</p>
<p>13</p>  <p>Drawer - Back Panel - 1 pc</p>	<p>14</p>  <p>Drawer Divider - 1 pc</p>	<p>15</p>  <p>Drawer Divider - 1 pc</p>

Part List

16A

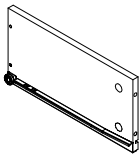

Drawer - Left Side Panel - 1 pc

16B

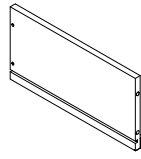

Drawer - Right Side Panel - 1 pc

17

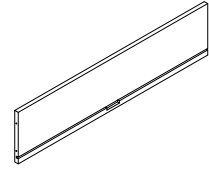

Drawer - Back Panel - 1 pc

18

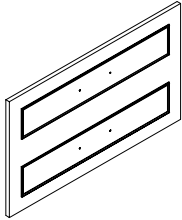

Drawer - Front Panel - 1 pc

19A

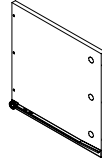

Drawer - Left Side Panel - 1 pc

19B

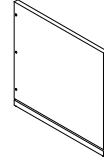





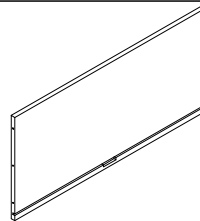

Drawer - Right Side Panel - 1 pc

20

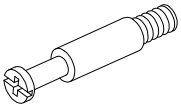
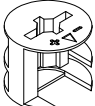
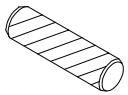
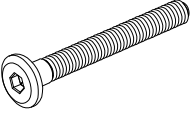
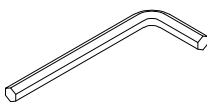
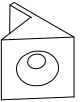
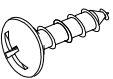
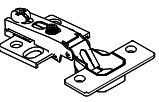

Drawer - Back Panel - 1 pc

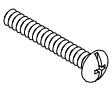
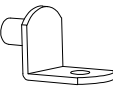
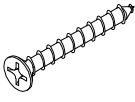
Hardware List

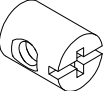
<p>A</p>  <p>Cam Bolt 16 pcs</p>	<p>B</p>  <p>Cam Lock 10mm 16 pcs</p>	<p>C</p>  <p>Ø8 x 30 mm Wood dowel 2 pcs</p>
<p>D</p>  <p>1/4" x 60 mm Hex-Head bolts 4 pcs</p>	<p>E</p>  <p>Allen Key 1 pc</p>	<p>F</p>  <p>Plastic Wedges 24 pcs</p>
<p>G</p>  <p>M3.5 x 15 mm Wood Screws 52 pcs</p>	<p>H</p>  <p>Hinge - 4 pcs</p>	<p>I</p>  <p>M3 x 15 mm Wood Screws 4 pcs</p>
<p>J</p>  <p>1 2 Magnets 2 set</p>	<p>K</p>  <p>Handles 6 pcs</p>	<p>L</p>  <p>M4 x 18 mm Truss Head Screw 12 pcs</p>
<p>M</p>  <p>Shelf Pin 9mm 4 pcs</p>	<p>N</p>  <p>M4 x 30 mm Wood Screws 14 pcs</p>	<p>O</p>  <p>1 2 3 4 5 Antifall 2 set</p>
<p>P</p>  <p>Ø11.5 x 15 mm Horizontal -Hole bolts 4 pcs</p>		

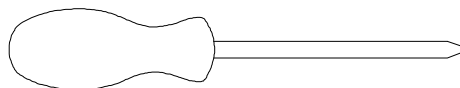

Assembly Tools Required (Not Included)

Step 1:

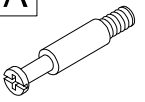
A	
2pcs	

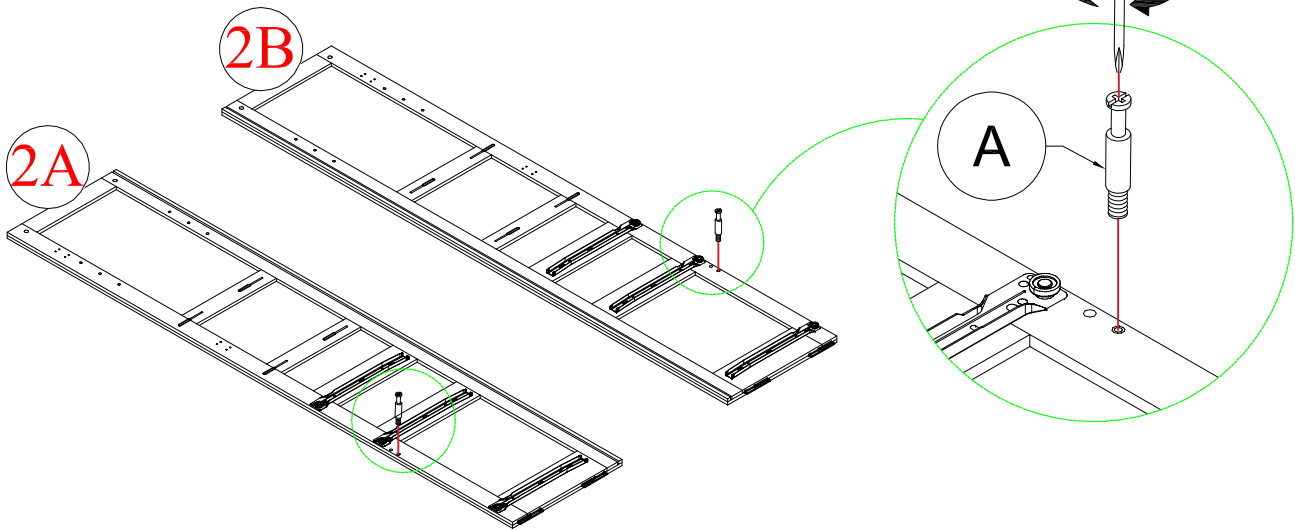

Step 2:

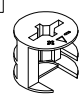
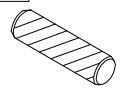
B		C	
2pcs		2pcs	

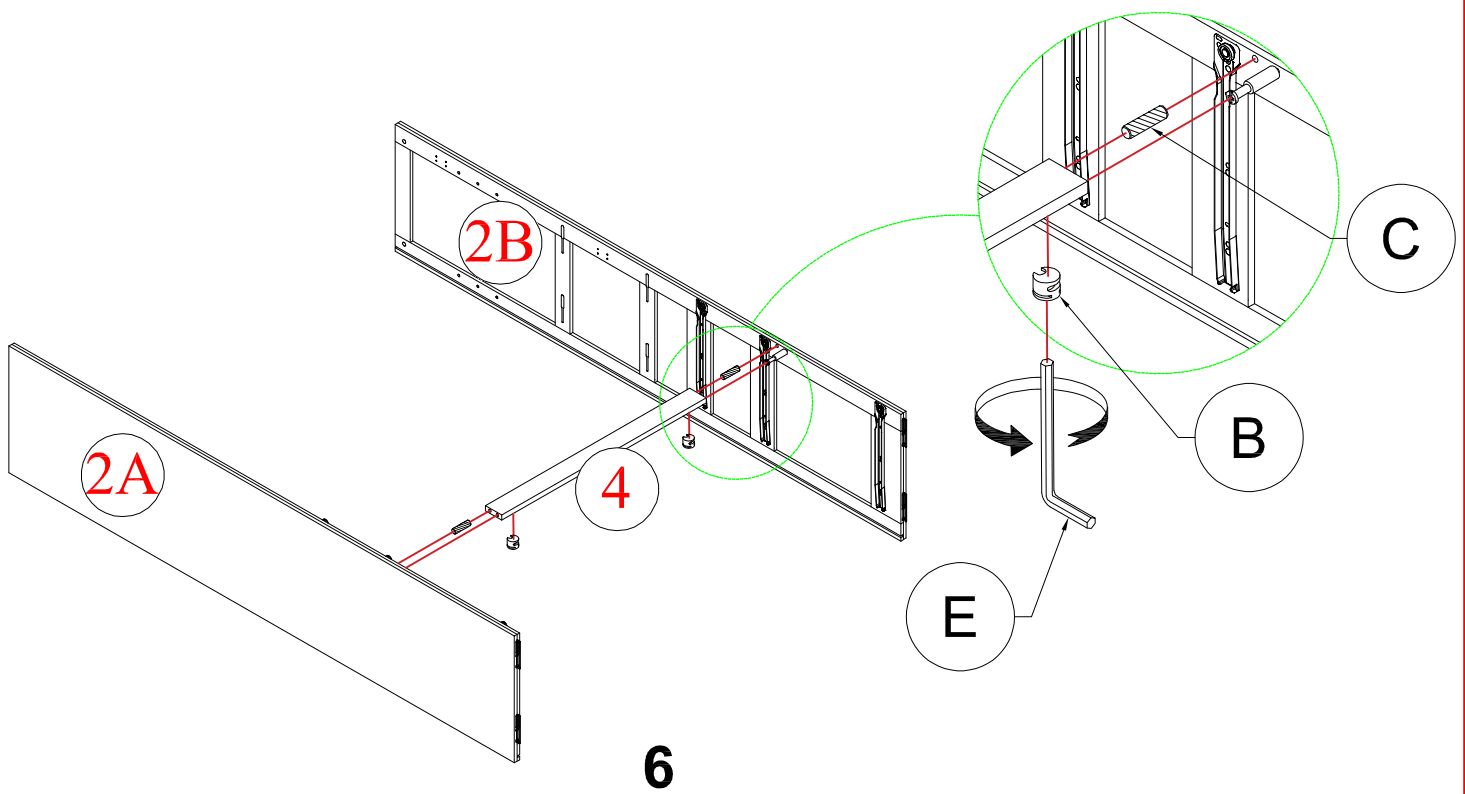

Step 3:

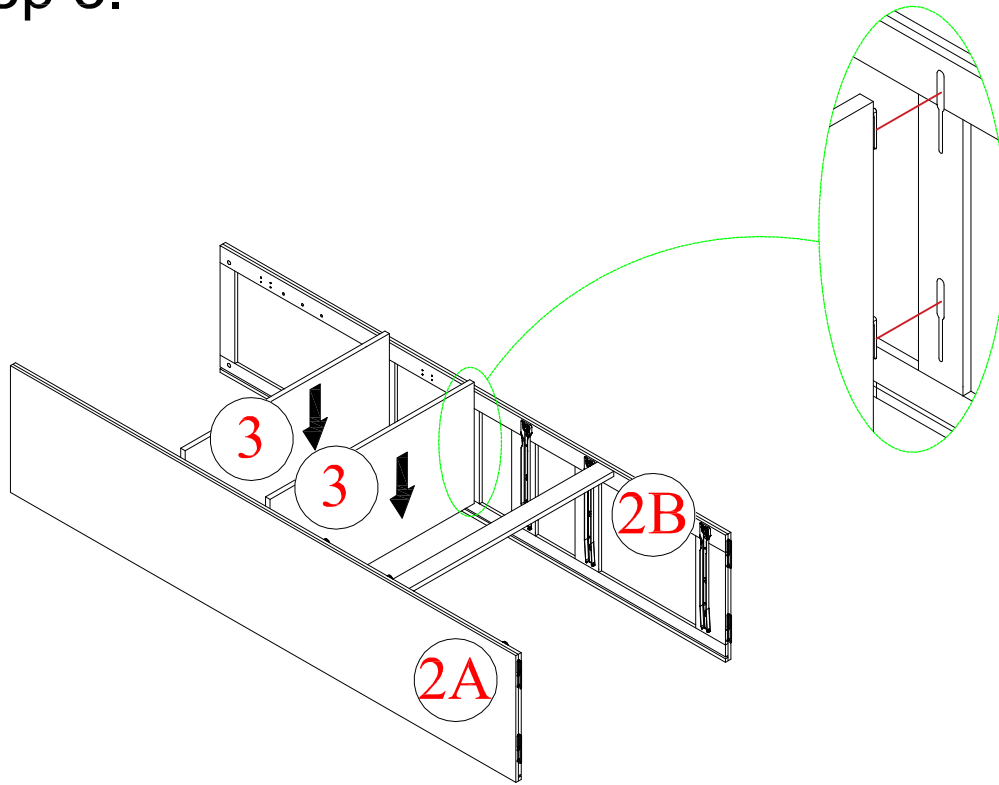

Step 4:

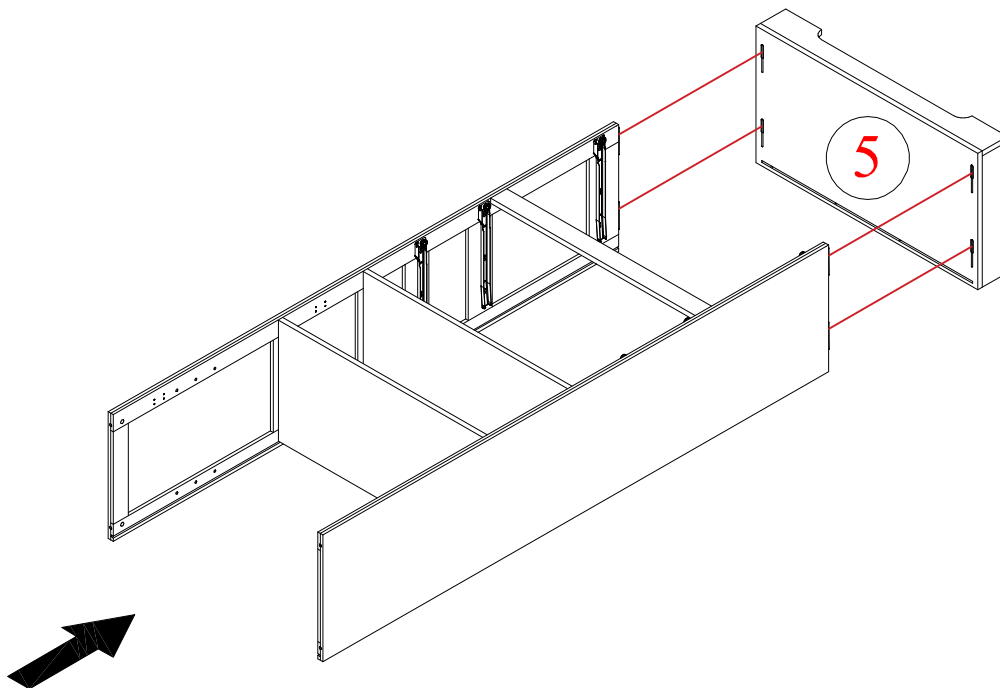

Step 5:

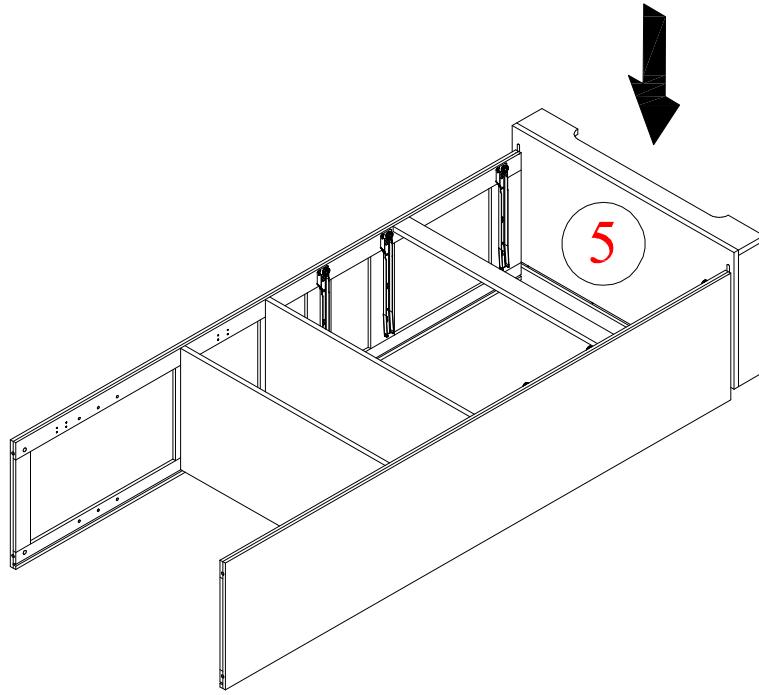

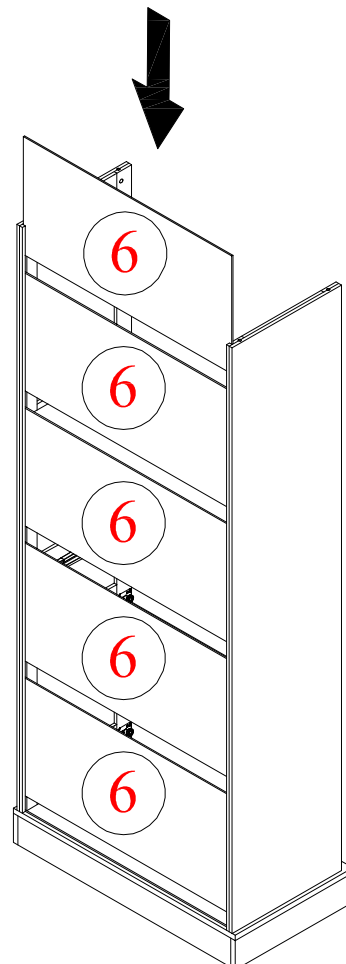

Step 6:

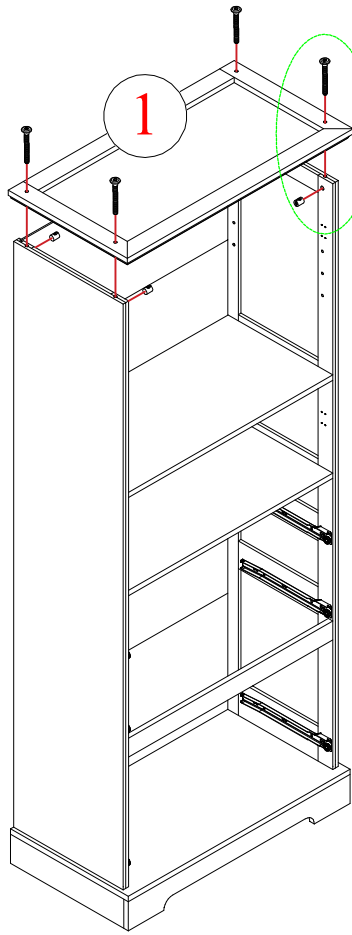

Step 7:

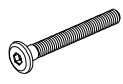

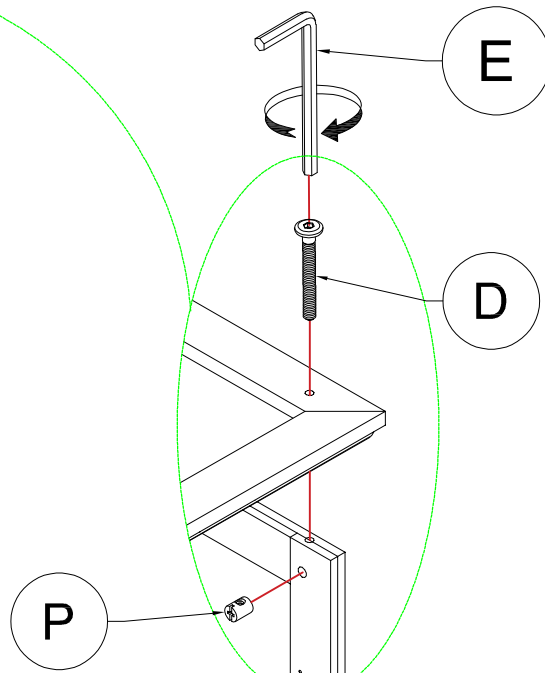

D	P
	
4pcs	4pcs

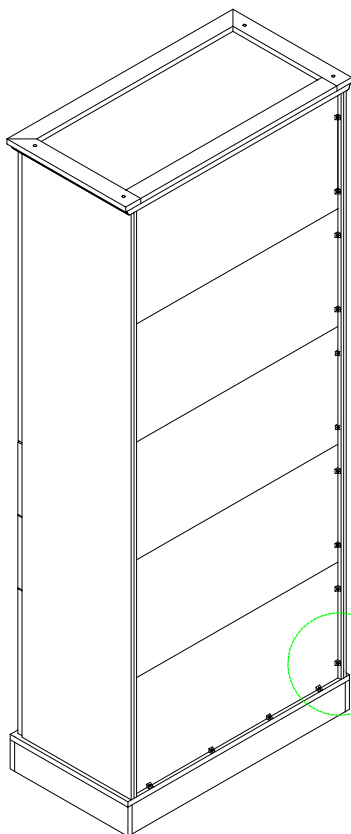

Step 8:



F	G
	
24pcs	24pcs

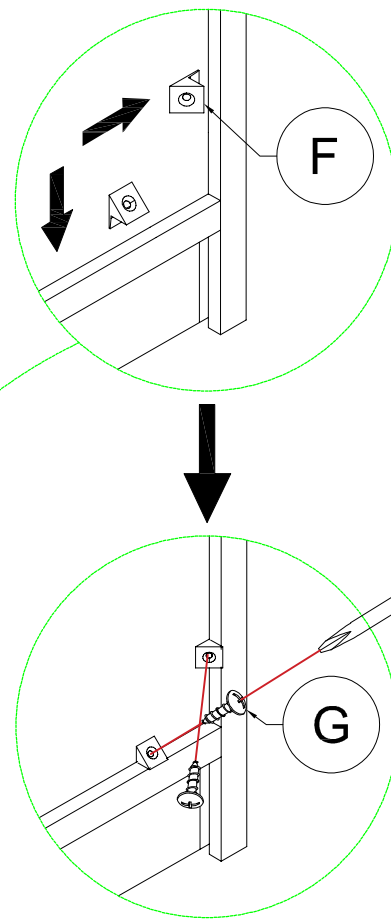

Step 9:

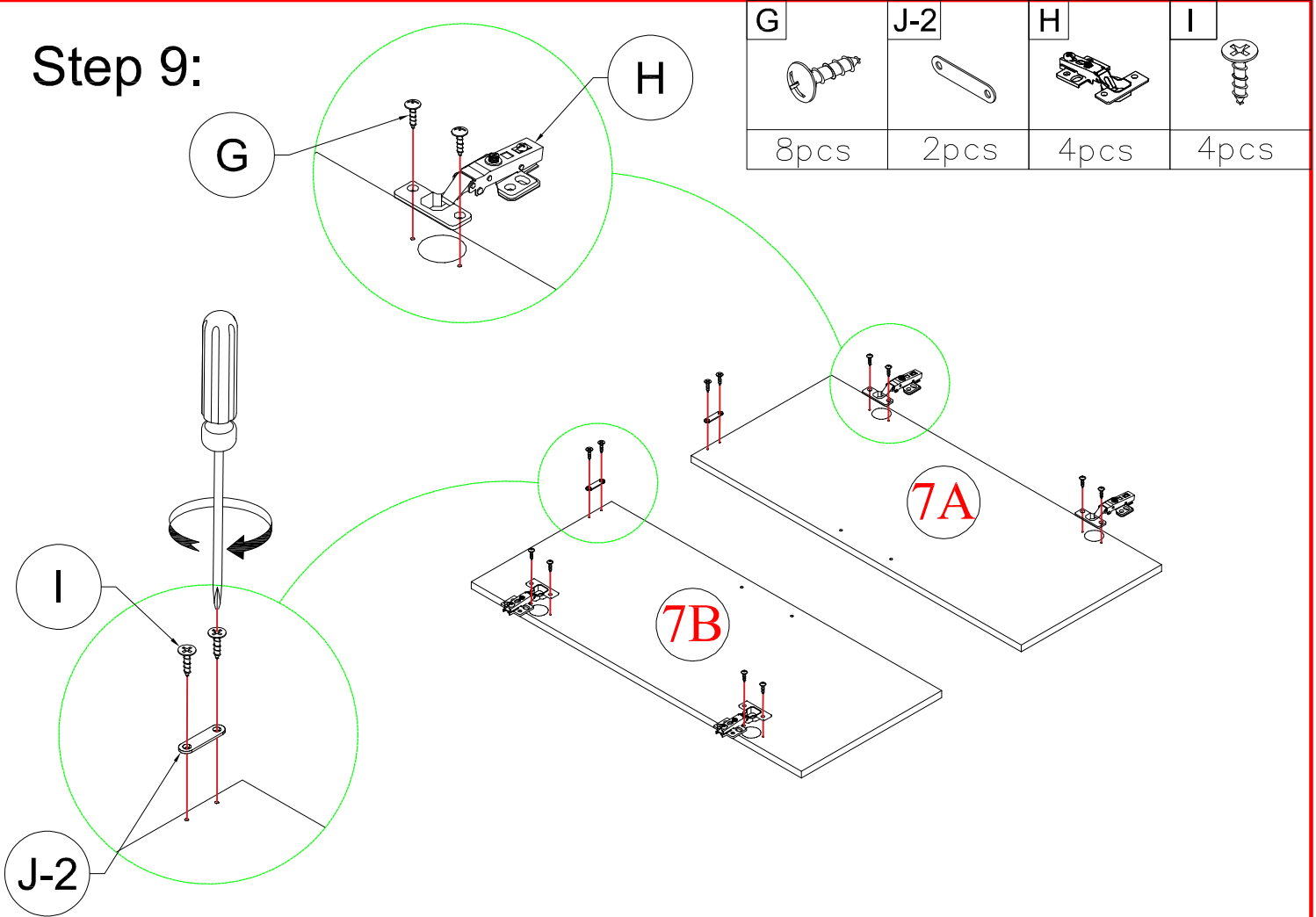

Step 10:

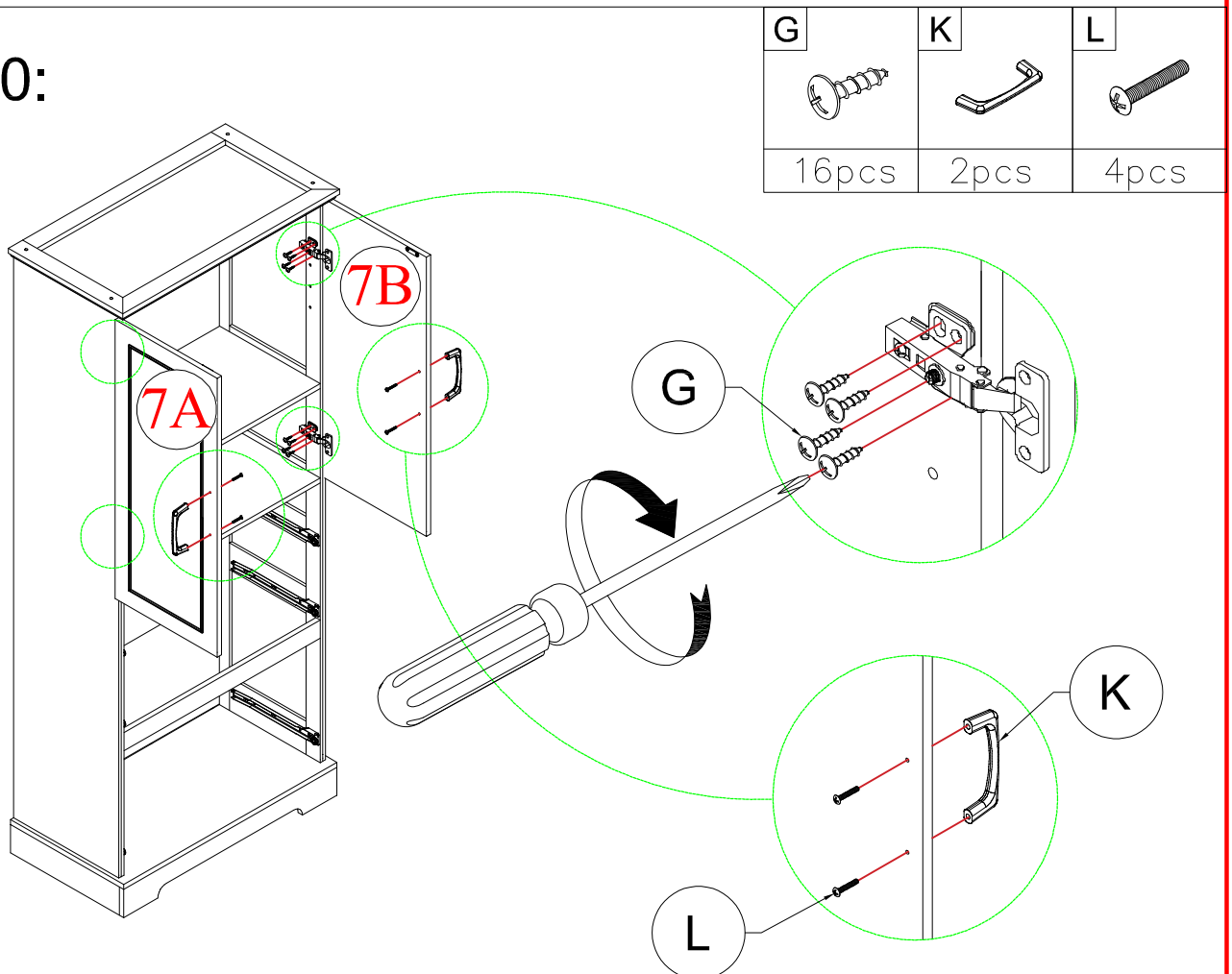

Step 11:

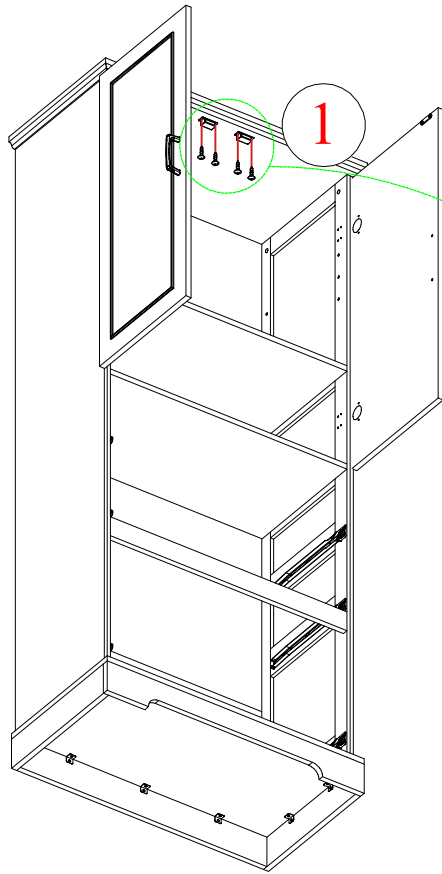

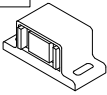
G 	J-1 
4pcs	2pcs

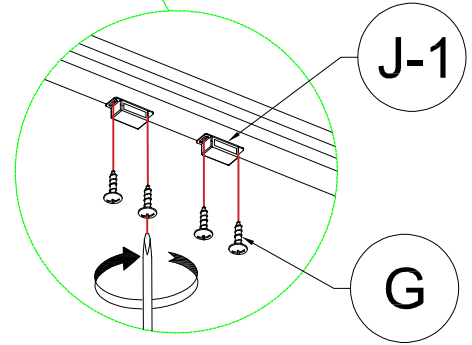

Step 12:

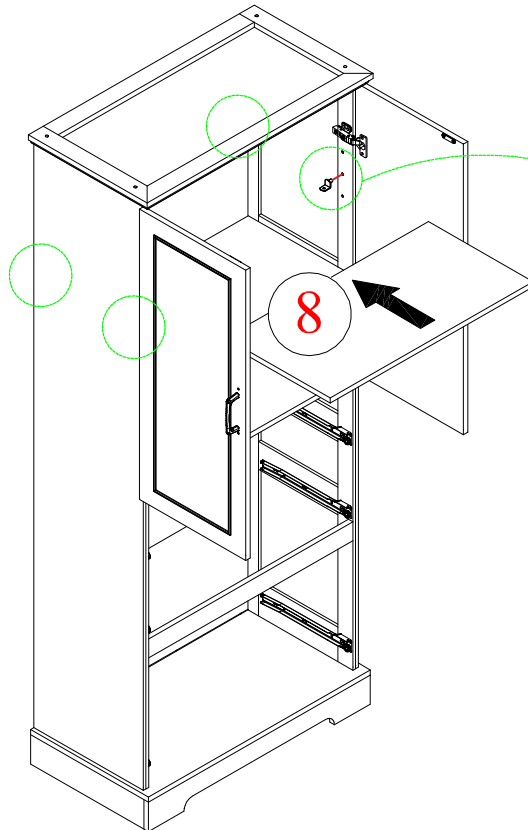

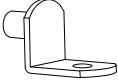
M 
4pcs

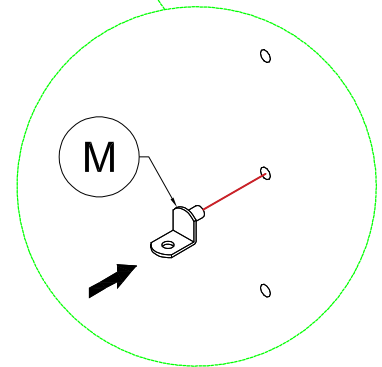

X4

Step 13:

G

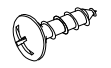

4pcs

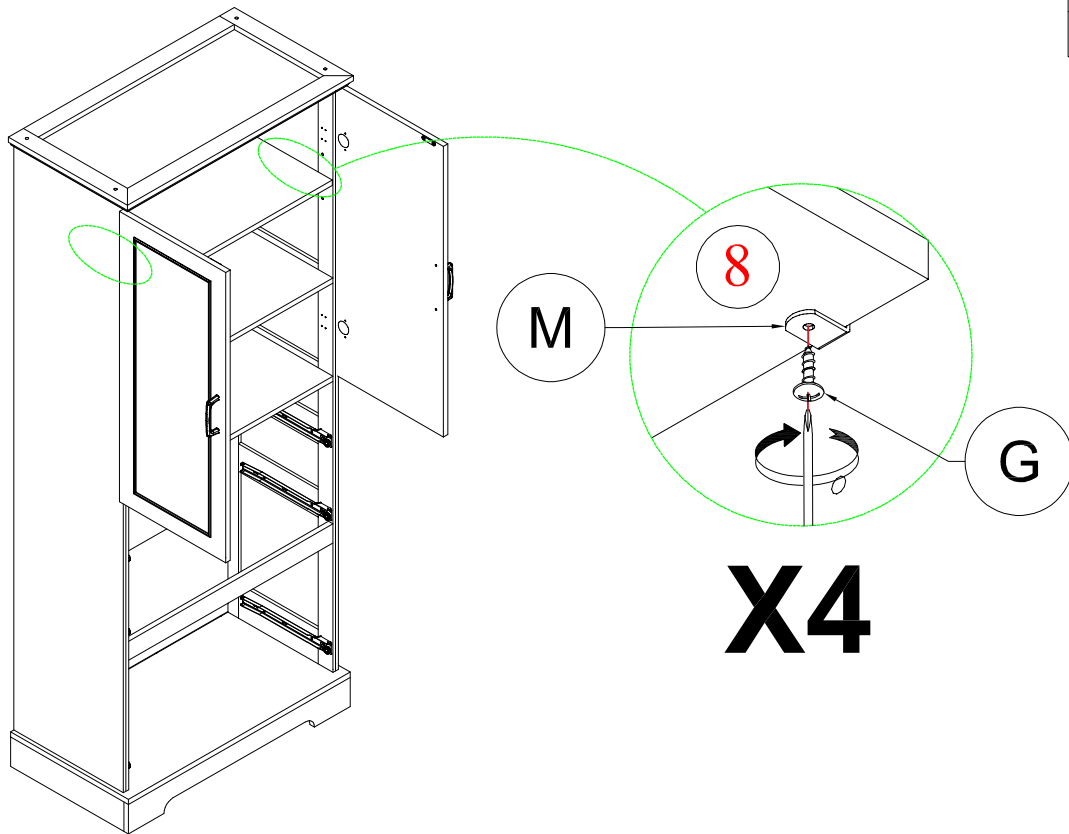

Step 14:

A

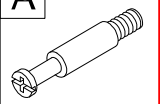

14pcs

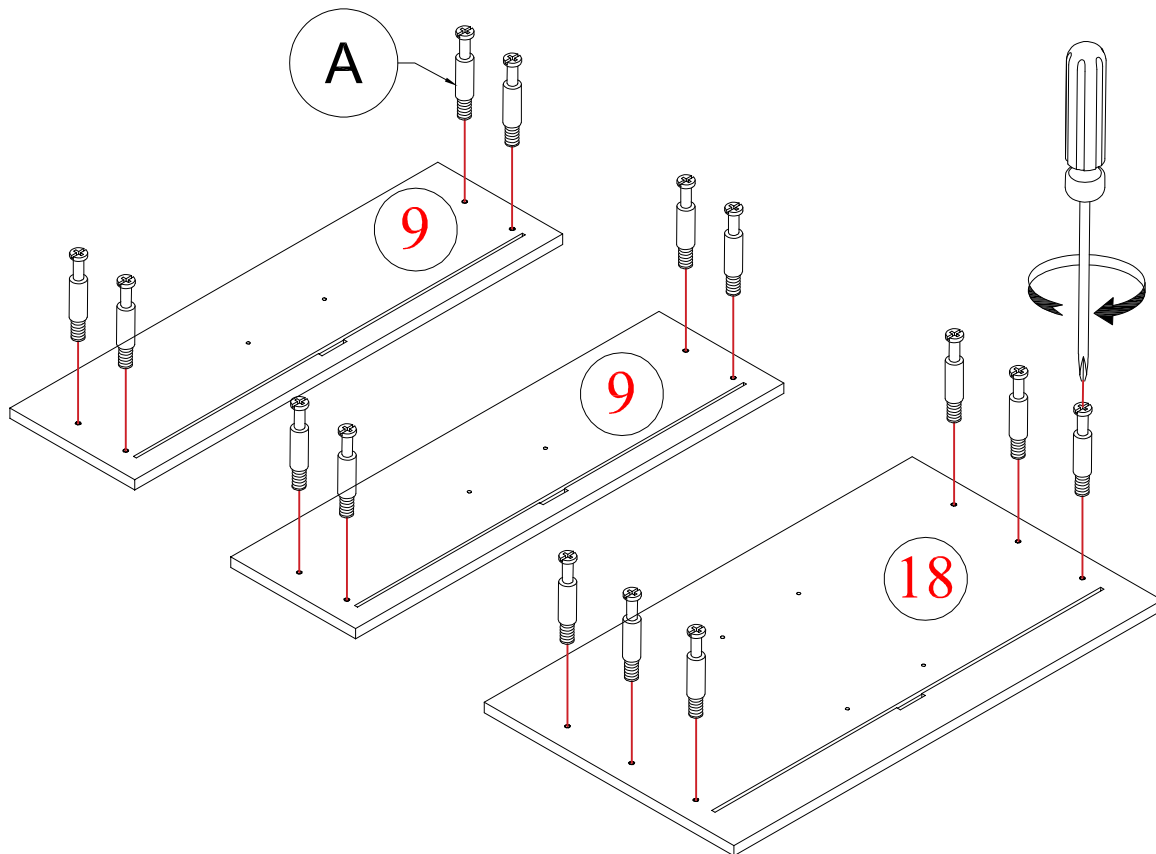

12

Step 15:

B



4pcs

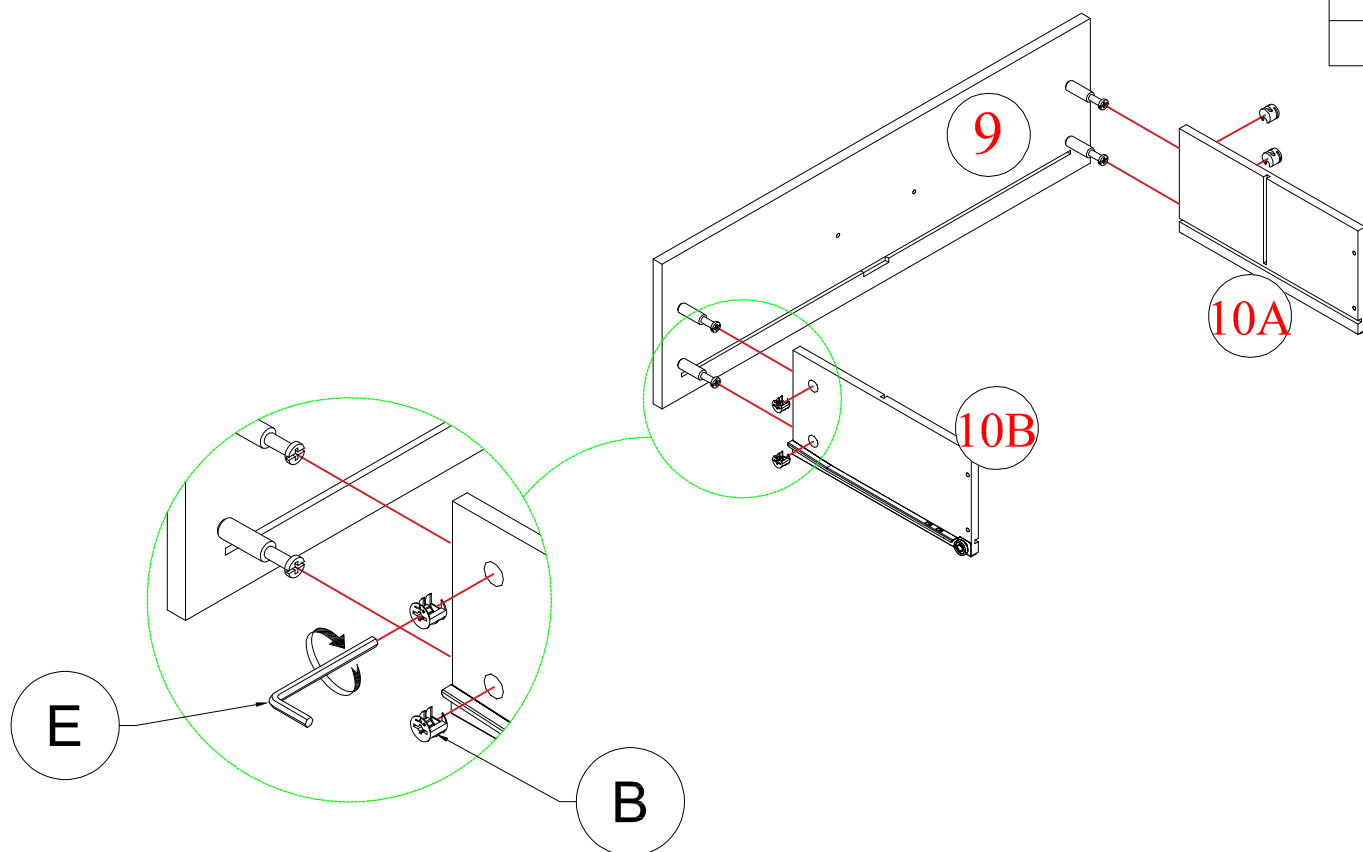

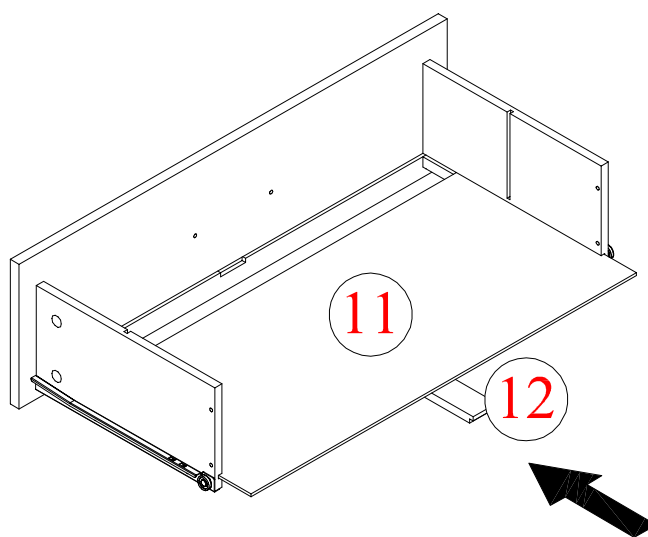

Step 16:



13

Step 17:

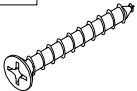
K	L	N
		
1pc	2pcs	4pcs

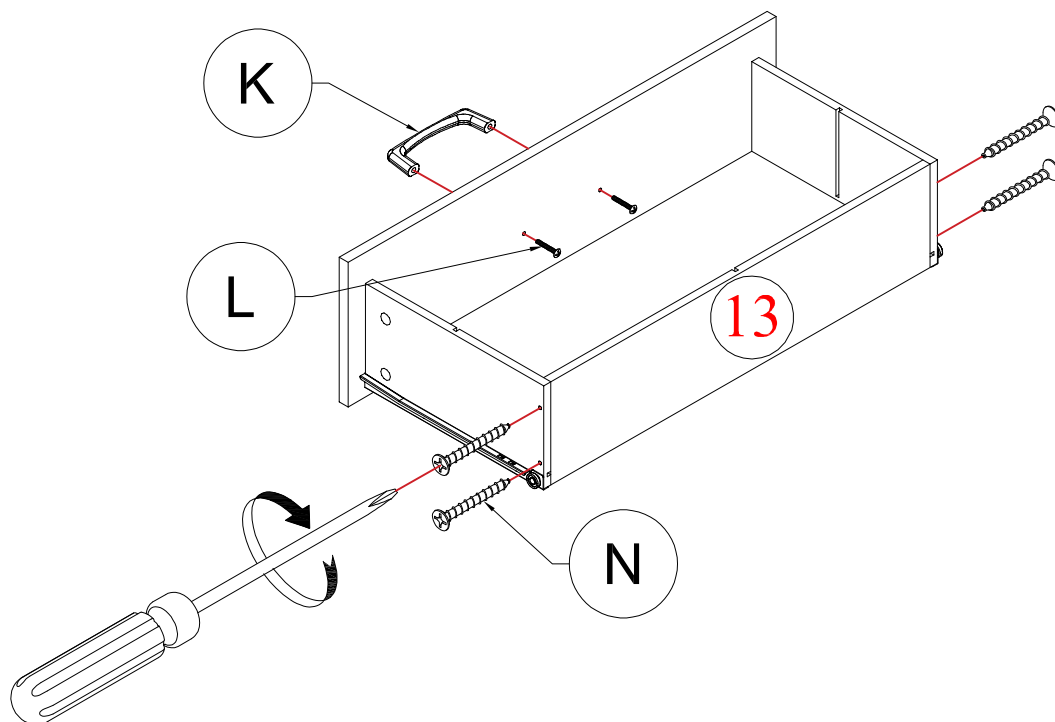

Step 18:

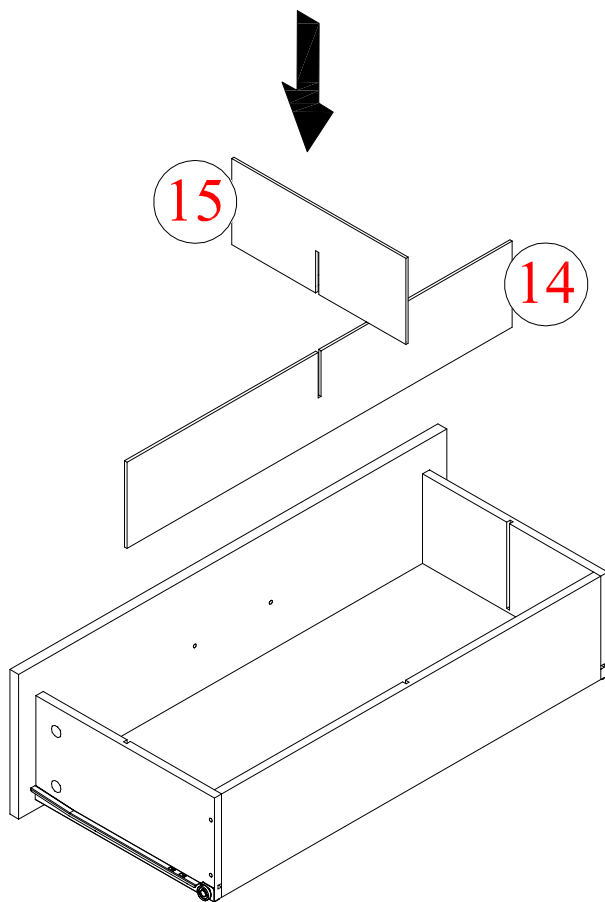

Step 19:

B



4pcs

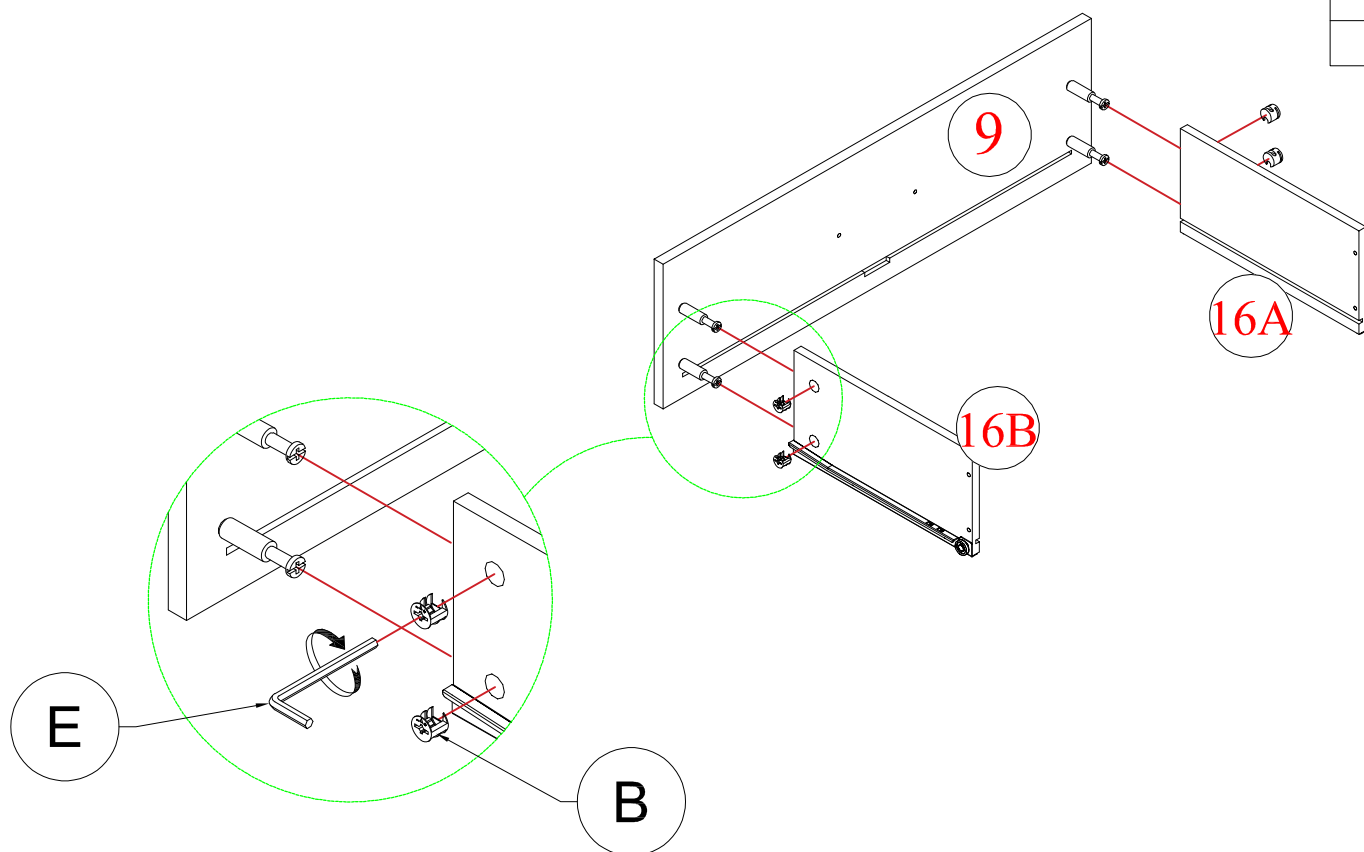

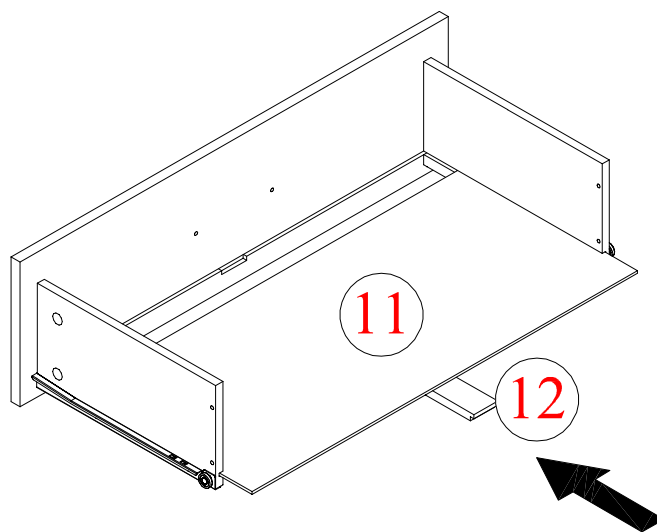

Step 20:



15

Step 21:

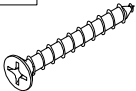
K	L	N
		
1pc	2pcs	4pcs

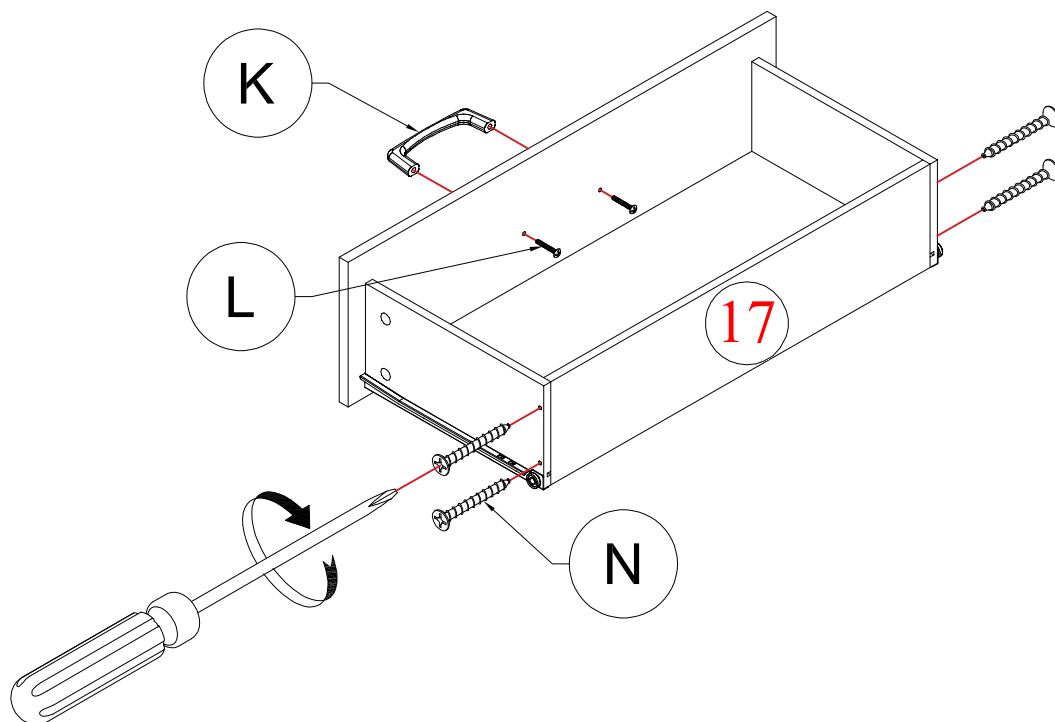

Step 22:

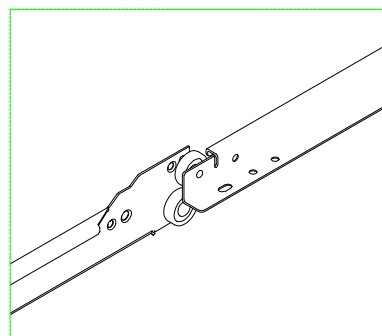
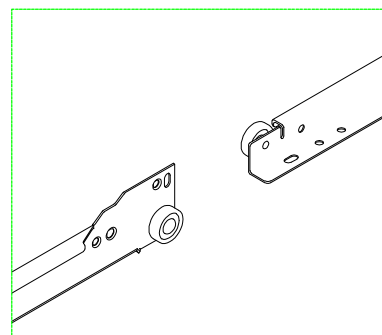
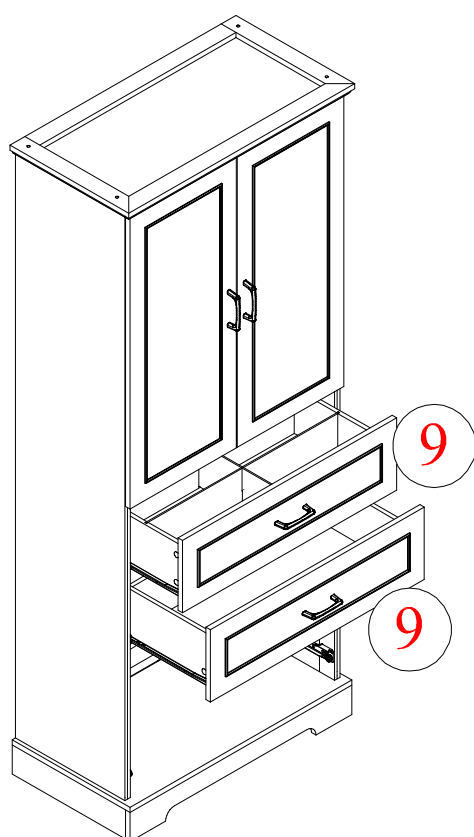

Step 23:

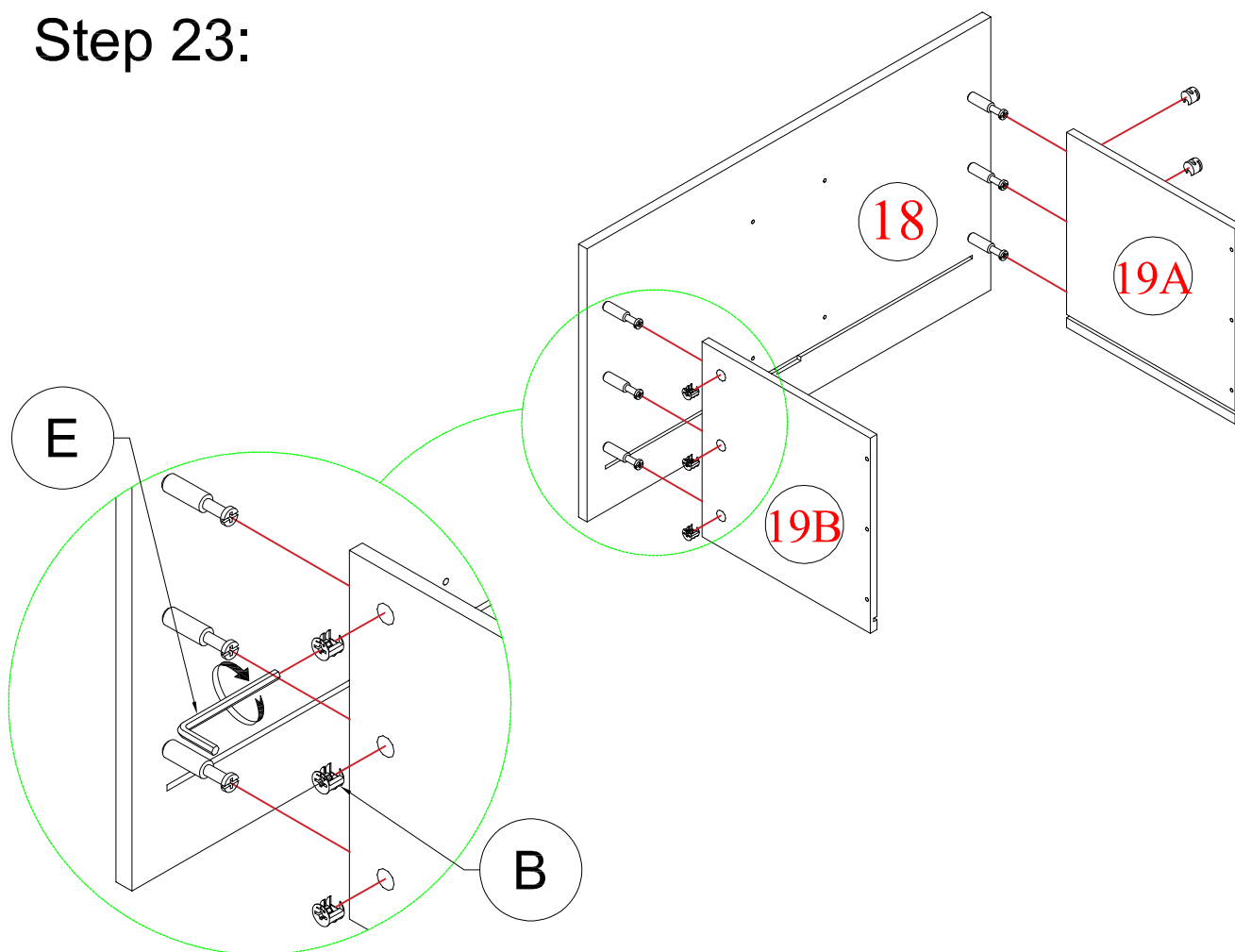

Step 24:

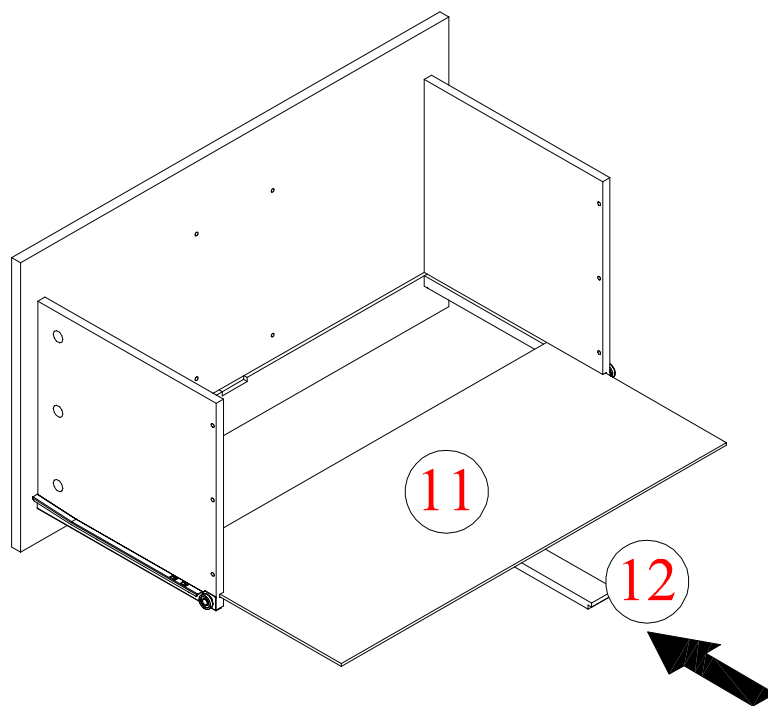

Step 25:

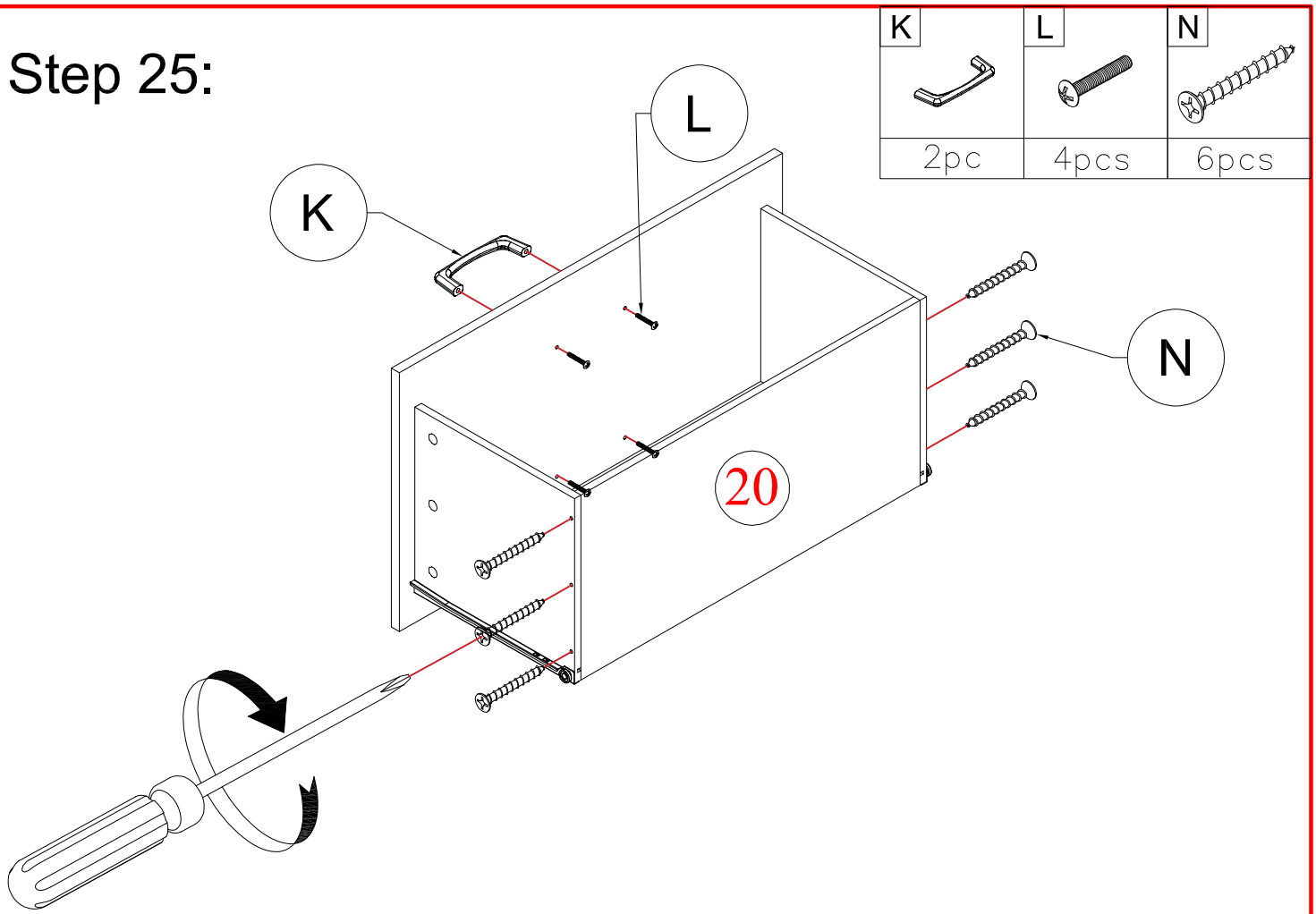

Step 26:

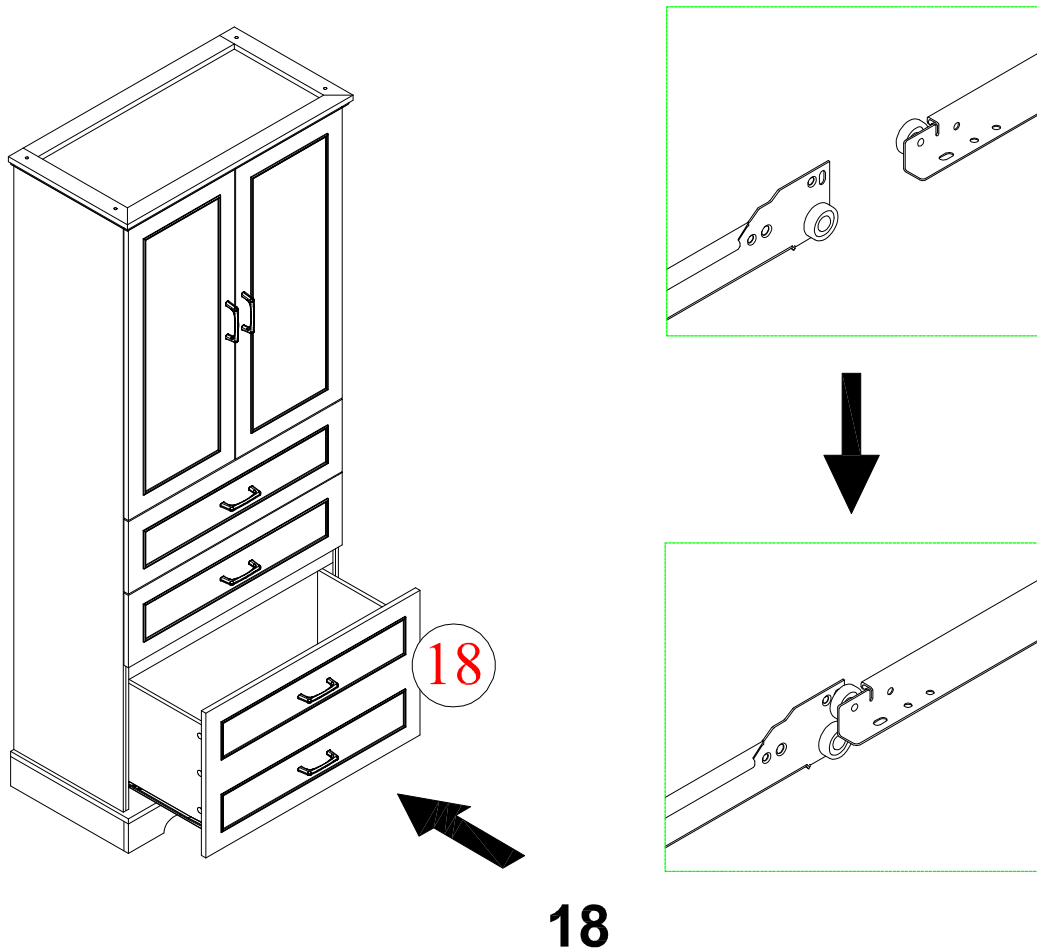

Step 27:

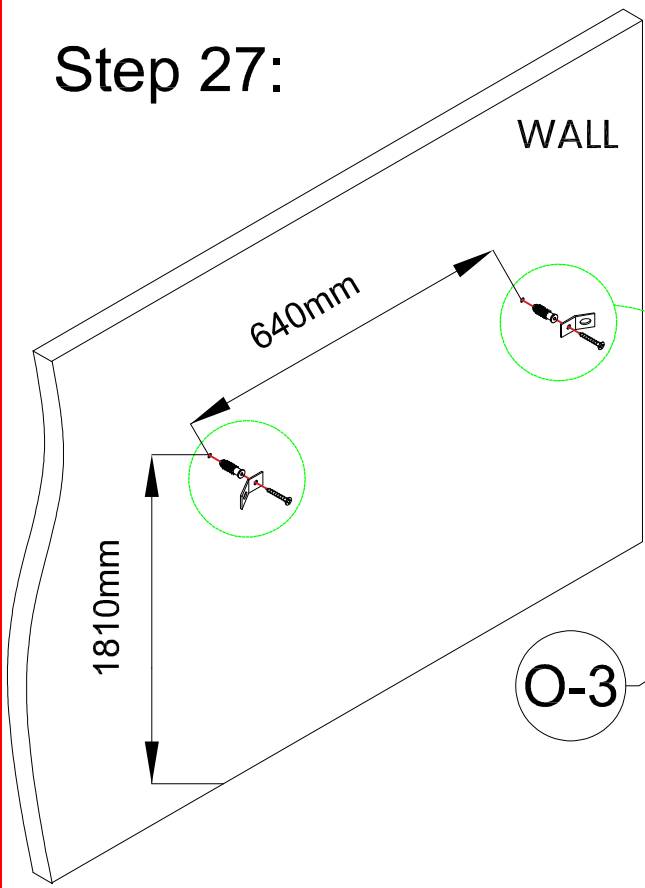

O-2	O-3	O-4
2pcs	2pcs	2pcs

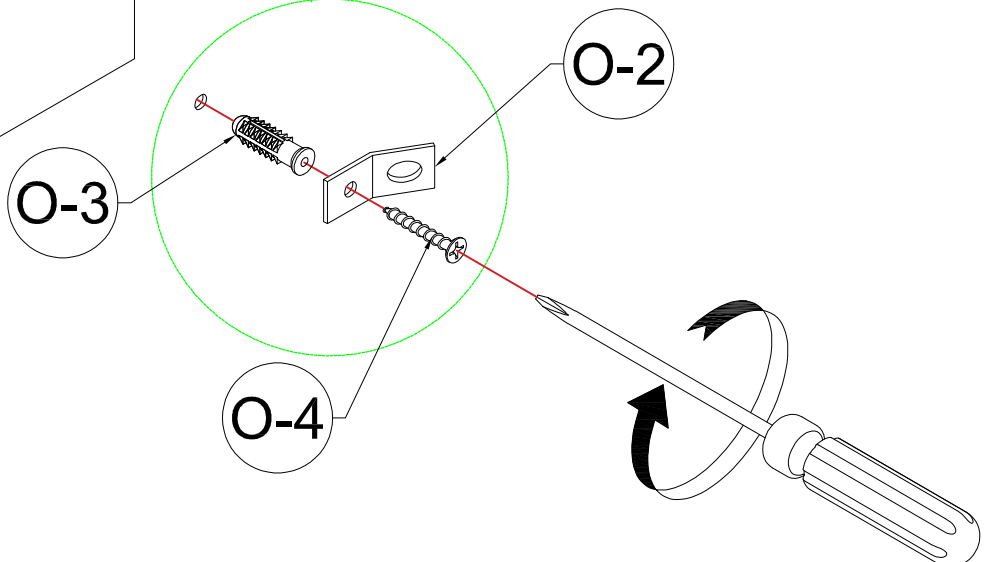

Step 28:

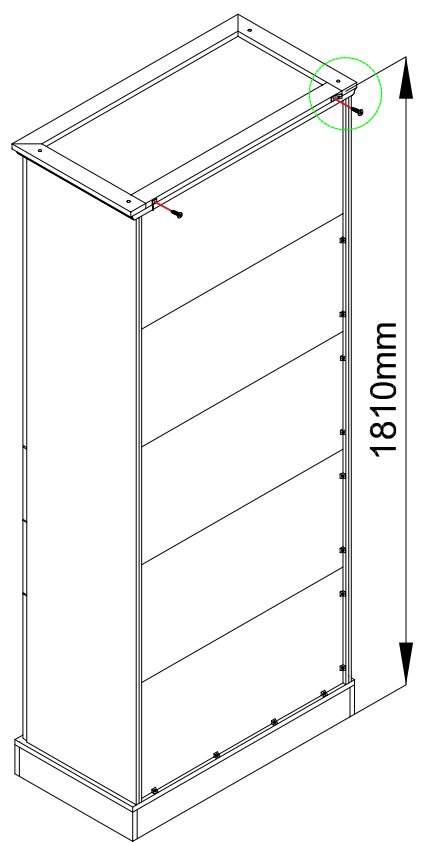

O-2	O-5
2pcs	2pcs

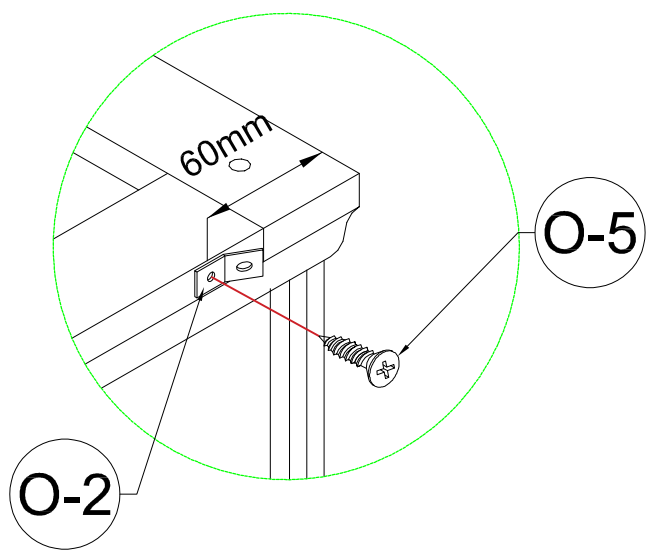

Step 29:

O-1



2pcs

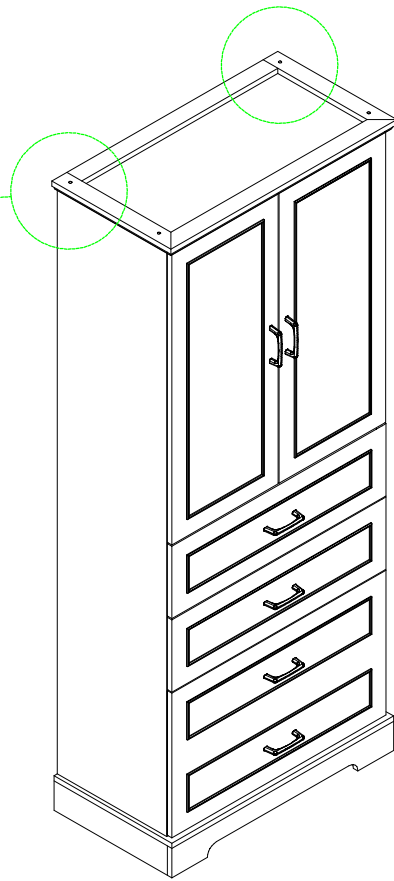
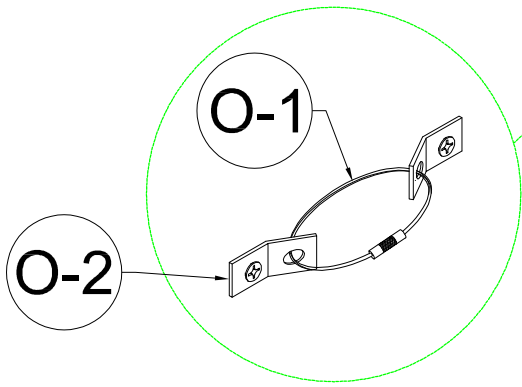

FINISH

