

**ASSEMBLY INSTRUCTIONS**  
**COASTER FINE FURNITURE**



*Fine Furniture for every stage of life*

**100438(B1&B2)**  
**Counter Height Table**  
**& Lazy Susan**

REVISION 0: 01/10/2007  
REVISION 1: 03/30/2012  
REVISION 2: 04/26/2012  
REVISION 3: 05/28/2020  
REVISION 4: 05/28/2024  
REVISION 5: 07/01/2024

# ITEM: 100438(B1&B2)



## ASSEMBLY INSTRUCTIONS

### ASSEMBLY TIPS :

1. Remove hardware from box and sort by size.
2. Please check to see that all hardware and parts are present prior to start of assembly.
3. Please follow attached instructions in the same sequence as numbered to assure fast & easy assembly.



### WARNING !

1. Don't attempt to repair or modify parts that are broken or defective. Please contact the store immediately.
2. This product is for home use only and not intended for commercial establishments.

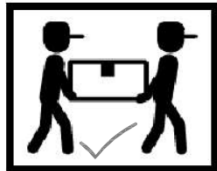



ASSEMBLY TIME



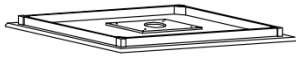

40 MINUTES

## PARTS IDENTIFICATION

### B1 (BOX 1)

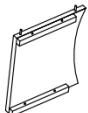





A	TOP WITH MOUNTING PLATE		1PC
G	LAZY SUSAN		1PC

### B2 (BOX 2)

B	LEG		4PCS
C	SIDE PANEL		2PCS
D	DOOR PANEL		2PCS
E	TOP PANEL		1PC
F	BOTTOM PANEL		1PC

## HARDWARE IDENTIFICATION

### Z-B2 (BOX 2) - HARDWARE PACK IS LOCATED IN 100438(B2)

1	ALLEN WRENCH (M4 x 110MM - BLK)		1PC
2	BOLT (M6 x 30MM - RBW)		24PCS
3	HEX HEAD SCREW (M7 x 40MM - RBW)		4PCS
4	KNOB WITH SCREW		2SETS
5	RUBBER DISC (356.21420)		8PCS
6	FLAT WASHER (5/16" - RBW)		4PCS

# ITEM: 100438(B1&B2)

## ASSEMBLY INSTRUCTIONS

### STEP 1

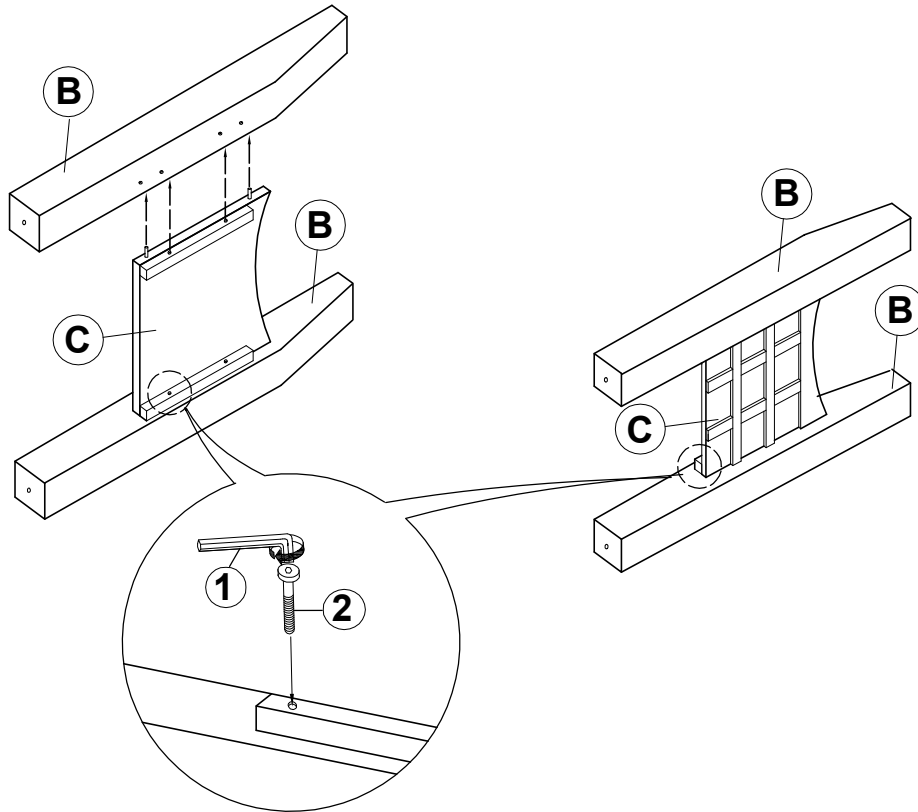

### STEP 2

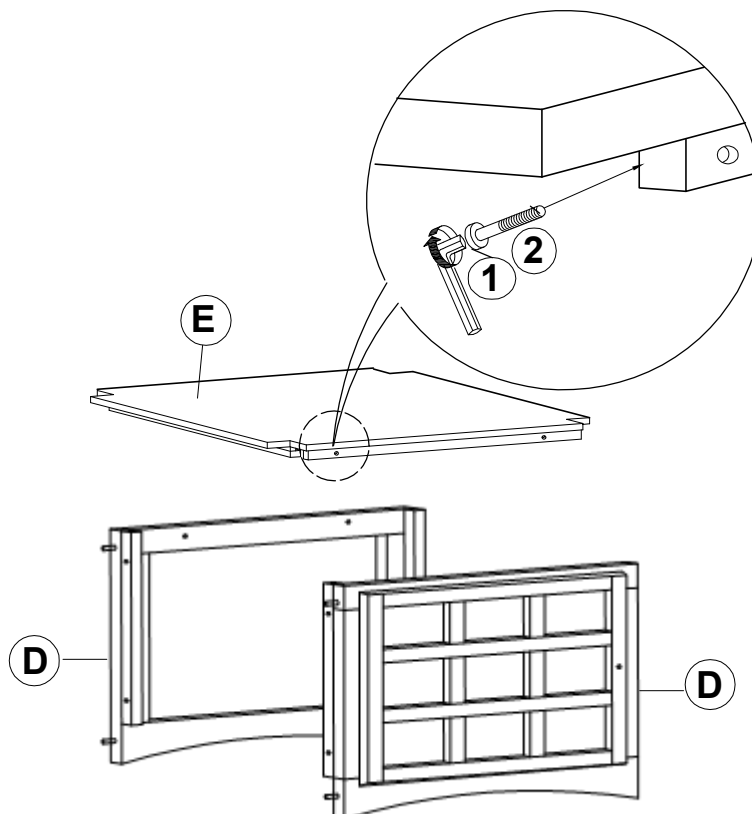

# ITEM: 100438(B1&B2)

## ASSEMBLY INSTRUCTIONS

### STEP 3

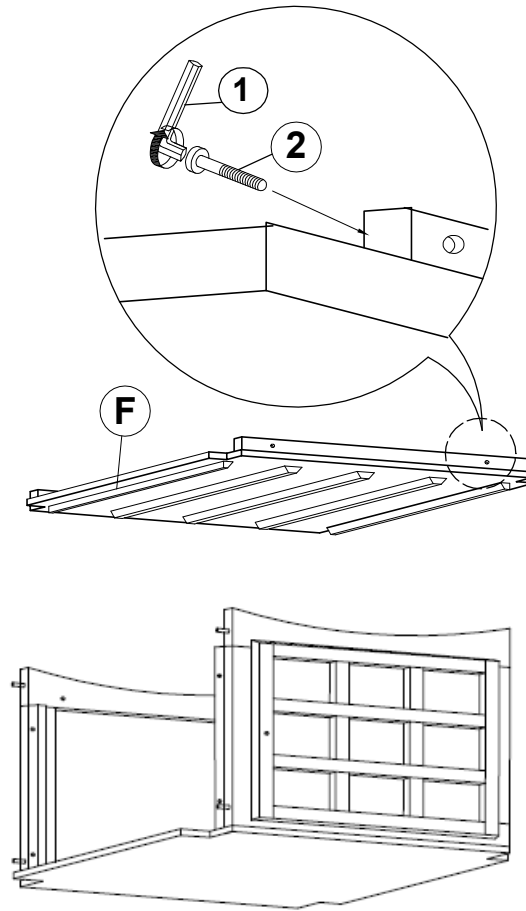

### STEP 4

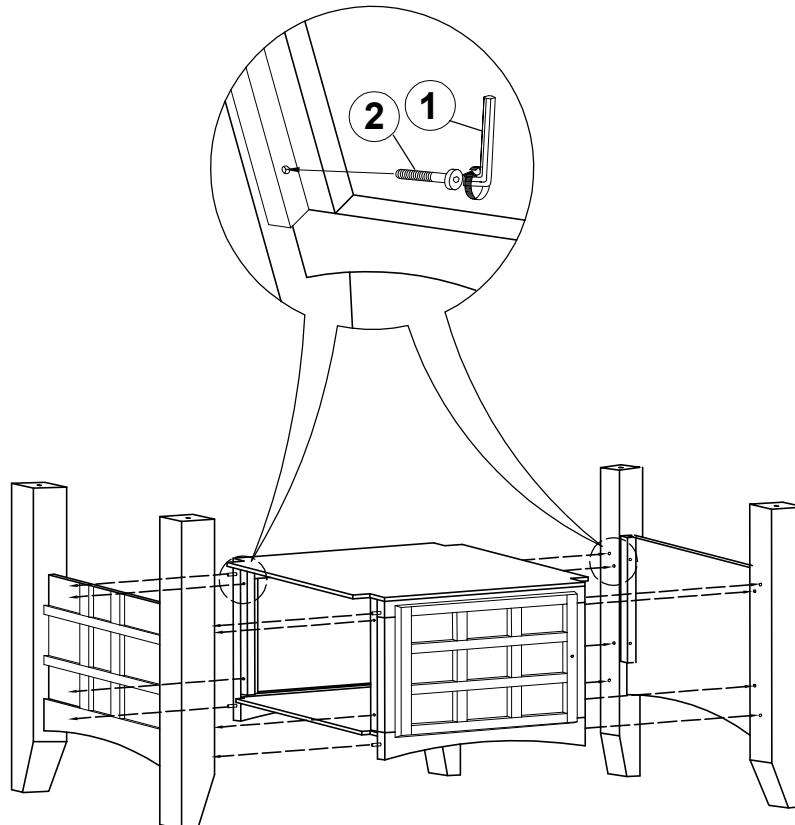

# ITEM: 100438(B1&B2)



## ASSEMBLY INSTRUCTIONS

### STEP 5

Attention:

Unscrew bolt with Allen wrench to detach the mounting plate from table top. Align and fasten mounting plate to legs using Allen cap screw and tighten with Allen wrench.  
(Please ensure the wood dowel on the mounting plate is facing up).

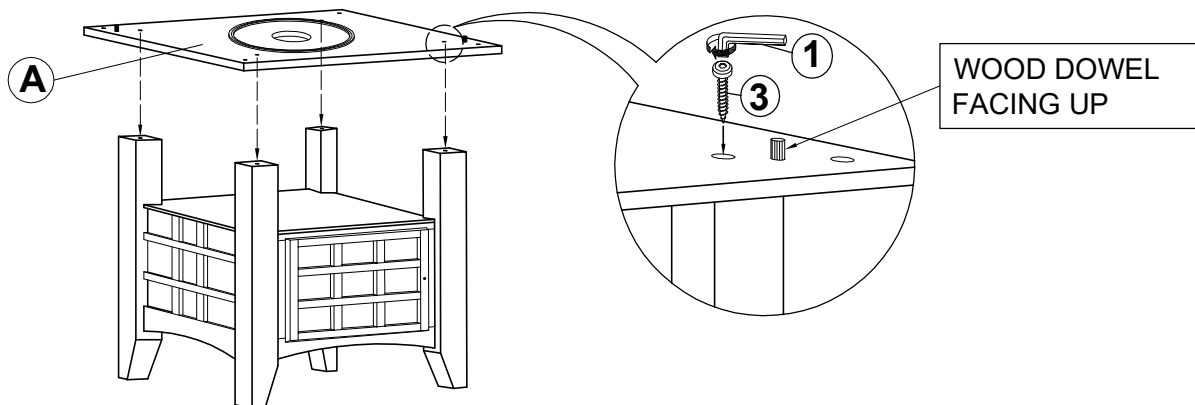
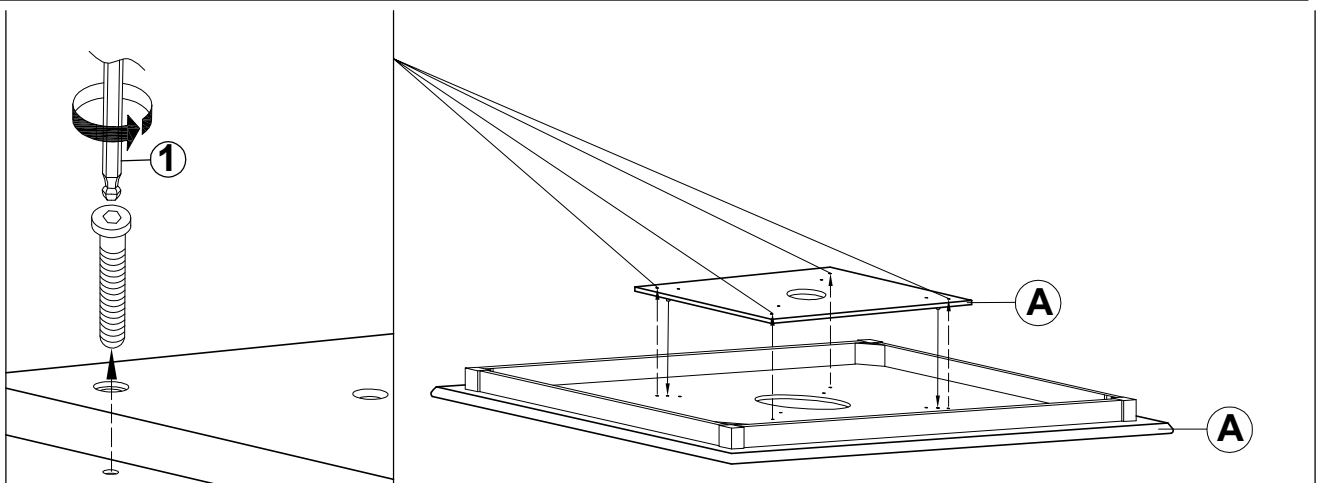

### STEP 6

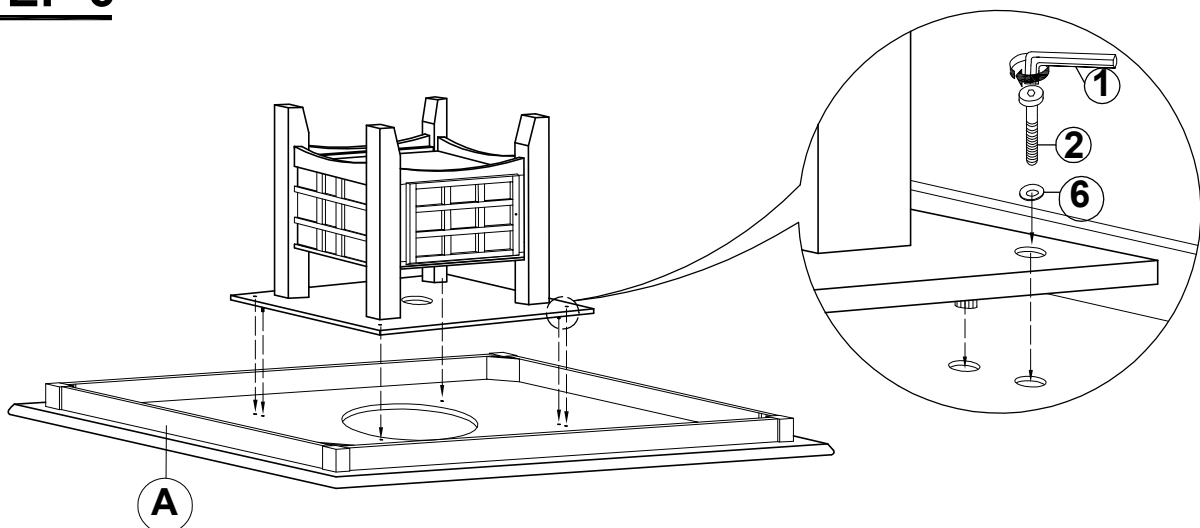

ITEM: **100438(B1&B2)**



**ASSEMBLY INSTRUCTIONS**

**STEP 7**

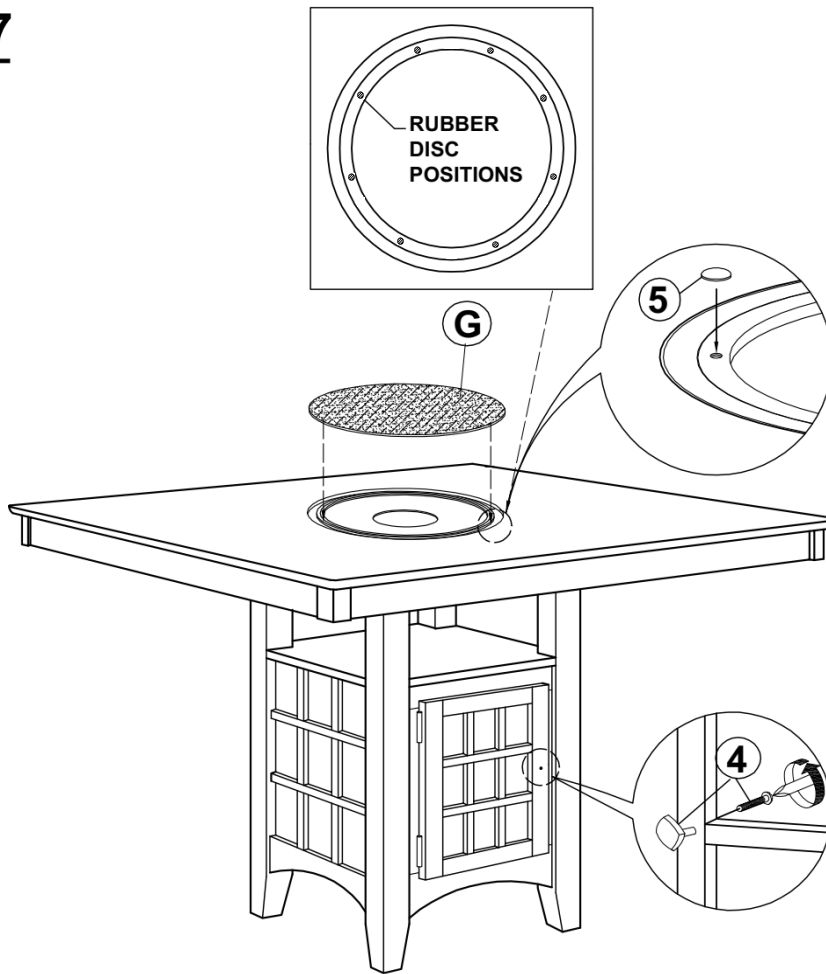

**STEP 8**  
**COMPLETE**

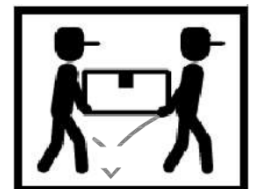
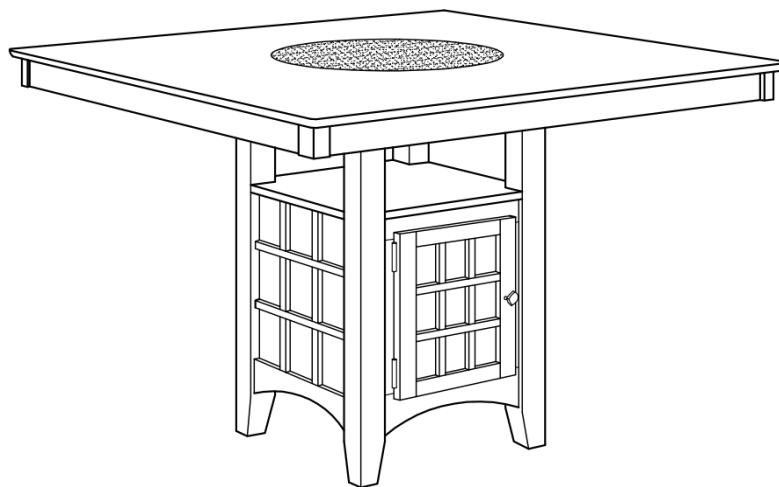

ITEM: **100438(B1&B2)**

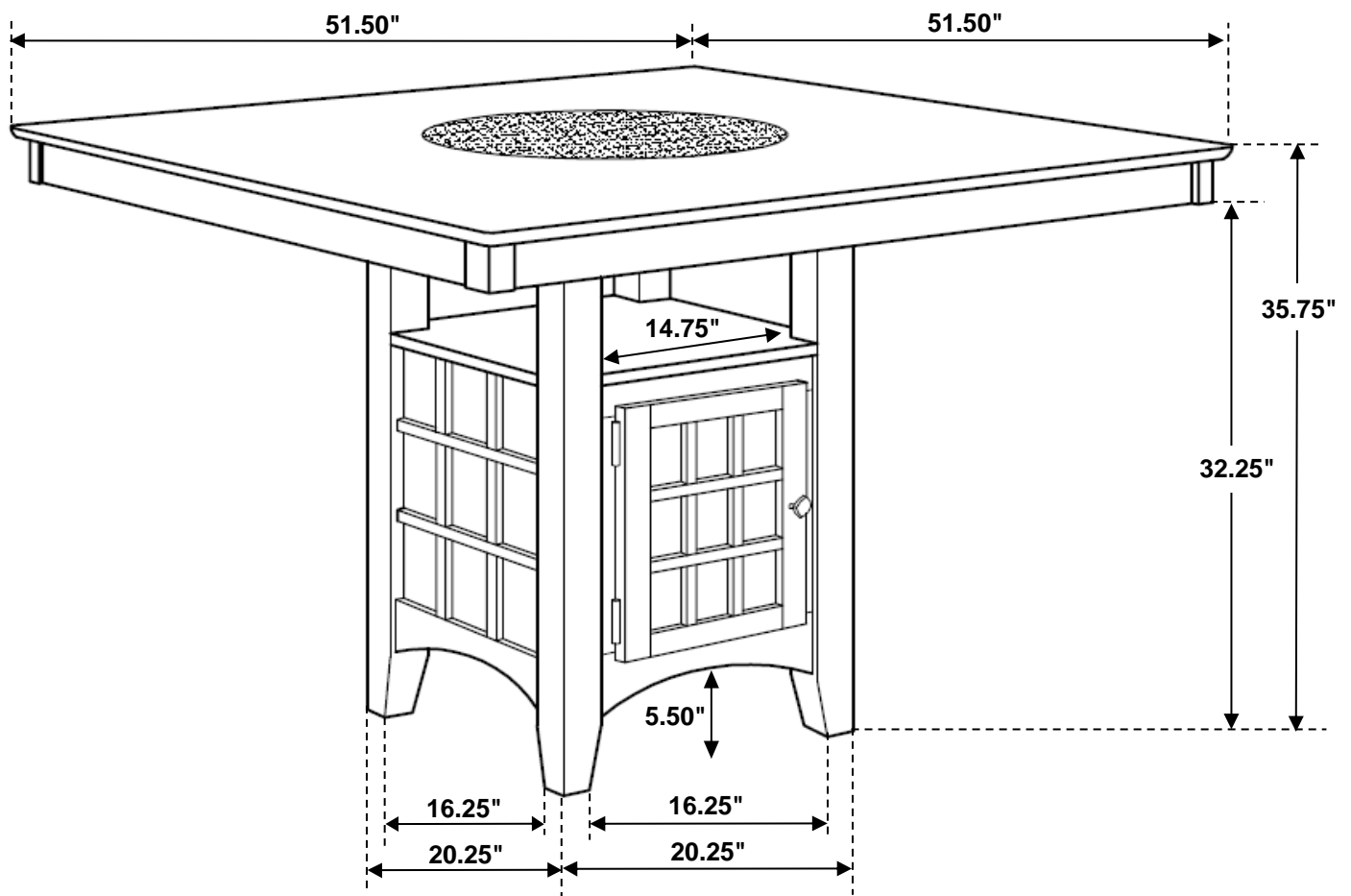

Note: Dimension tolerance  $\pm 5\%$

**ASSEMBLY INSTRUCTIONS**  
**COASTER FINE FURNITURE**



*Fine Furniture for every stage of life*

**100219**  
**Counter Height Chair**

REVISION 0: 01/10/2006  
REVISION 1: 03/15/2012  
REVISION 2: 04/18/2016  
REVISION 3: 12/11/2020

# ITEM: 100219



## ASSEMBLY INSTRUCTIONS

### ASSEMBLY TIPS :

1. Remove hardware from box and sort by size.
2. Please check to see that all hardware and parts are present prior to start of assembly.
3. Please follow attached instructions in the same sequence as numbered to assure fast & easy assembly.



### WARNING !







1. Don't attempt to repair or modify parts that are broken or defective. Please contact the store immediately.
2. This product is for home use only and not intended for commercial establishments.



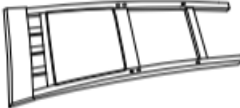



ASSEMBLY TIME

20 MINUTES

## PARTS IDENTIFICATION

A	BACK FRAME		1PC
B	FRONT LEG FRAME		1PC
C	SIDE RAIL		2PCS
D1	RIGHT SIDE STRETCHER		1PC
E1	LEFT SIDE STRETCHER		1PC
F	SEAT CUSHION		1PC

## HARDWARE IDENTIFICATION

1	ALLEN WRENCH (M4 x 110mm - BLK)		1PC
2	BOLT (M6 x 50mm- RBW)		6PCS
3	LOCK WASHER (1/4" - BLK)		6PCS
4	SHORT PAN HEAD SCREW (#8 X 1" - BLK)		4PCS
5	LONG PAN HEAD SCREW (#8 X 1 1/2" - BLK)		4PCS

### NOTE :

Phillips head screw driver is required in the assembly process ; However, manufacturer does not provide this item. Quantities shown are for one chair.

ITEM: **100219**



**ASSEMBLY INSTRUCTIONS**  
**STEP 1**

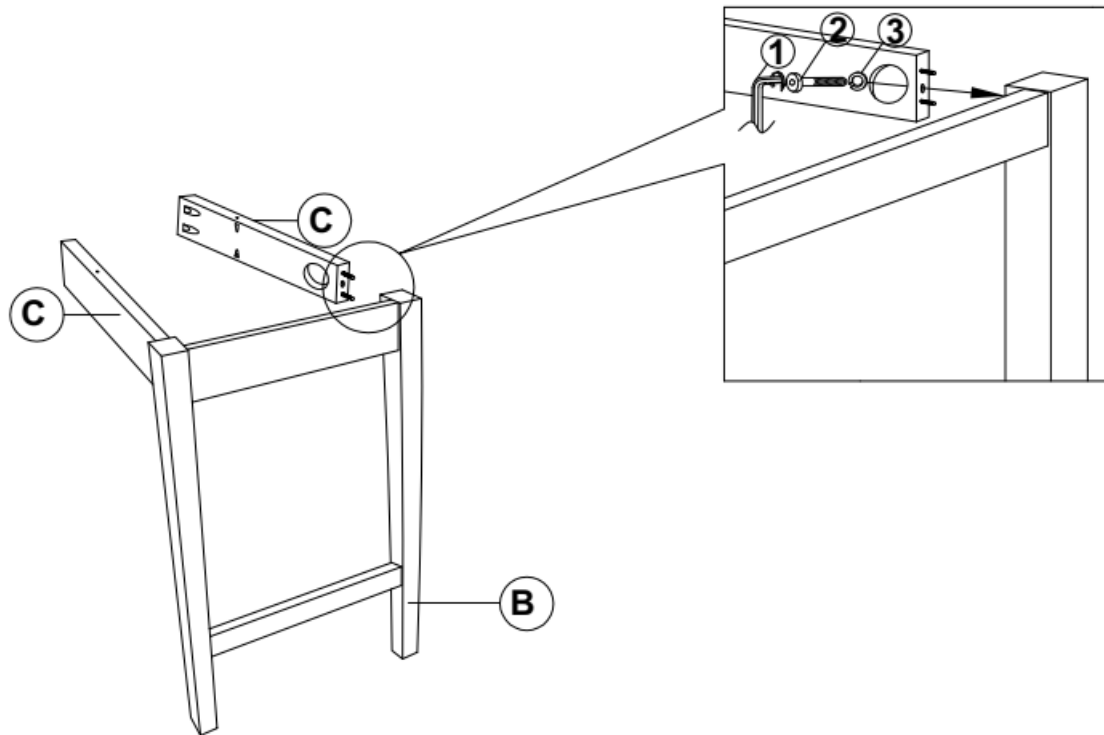

**STEP 2**

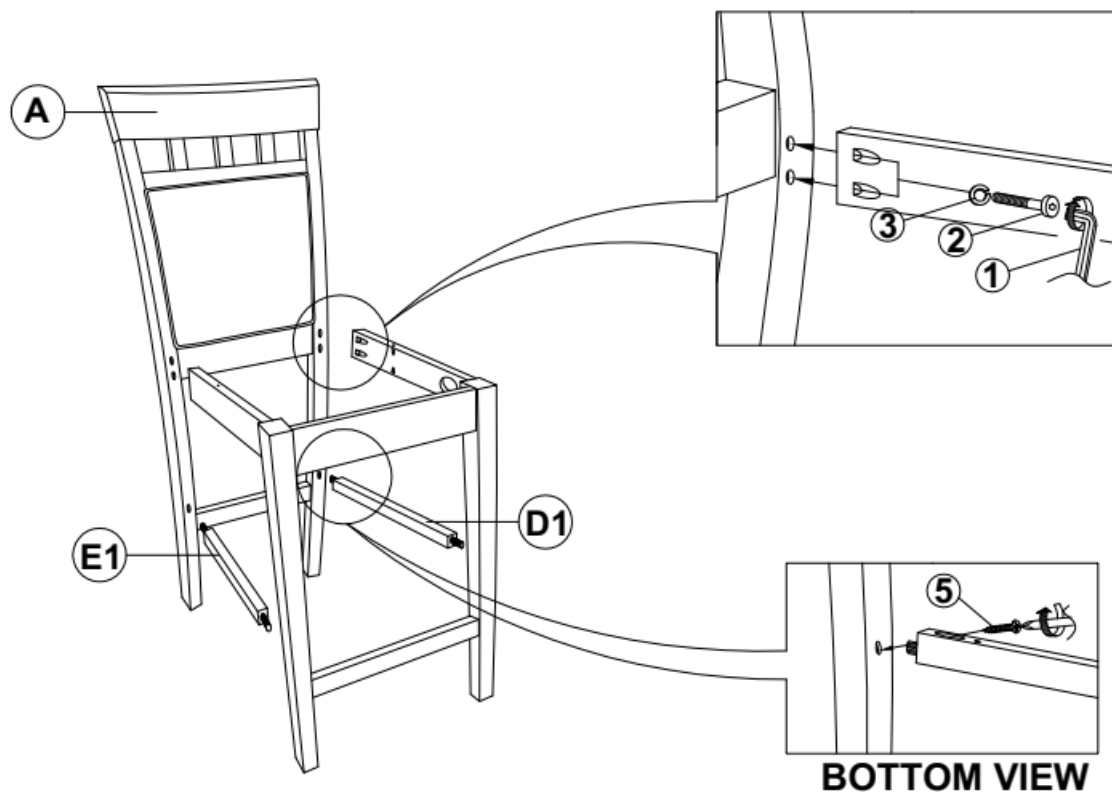

**BOTTOM VIEW**

ITEM: **100219**



**ASSEMBLY INSTRUCTIONS**

**STEP 3**

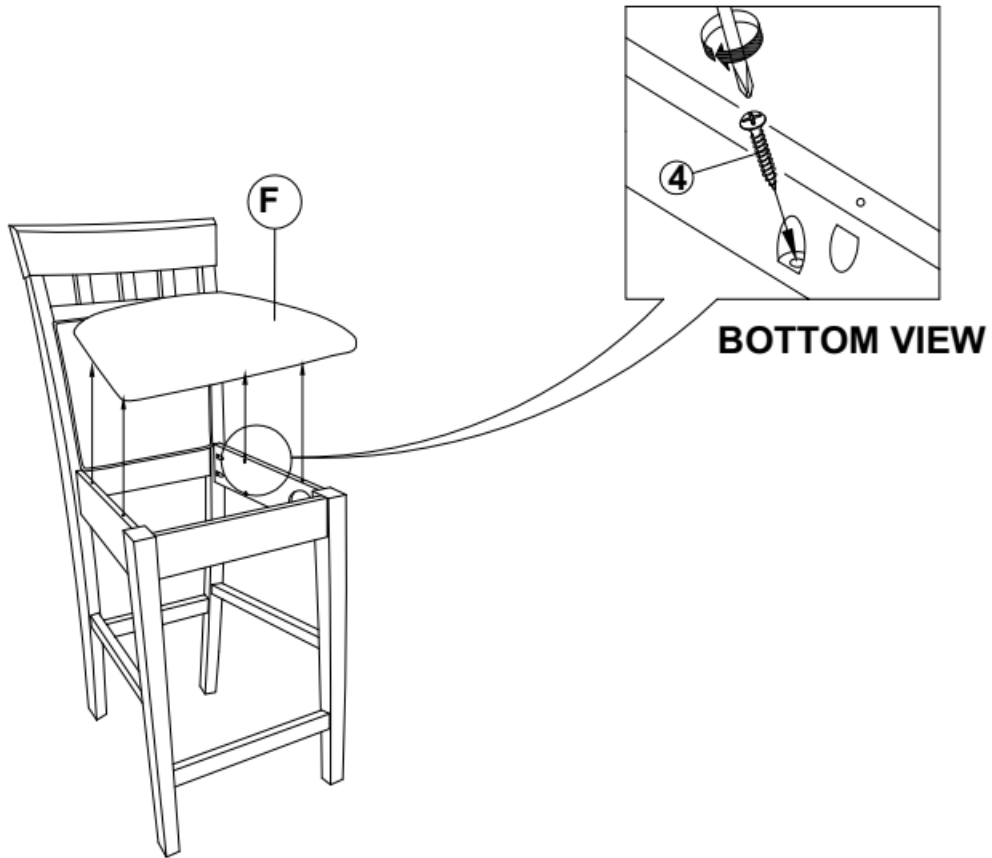

**STEP 4**  
**COMPLETE**

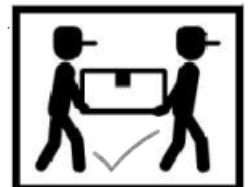
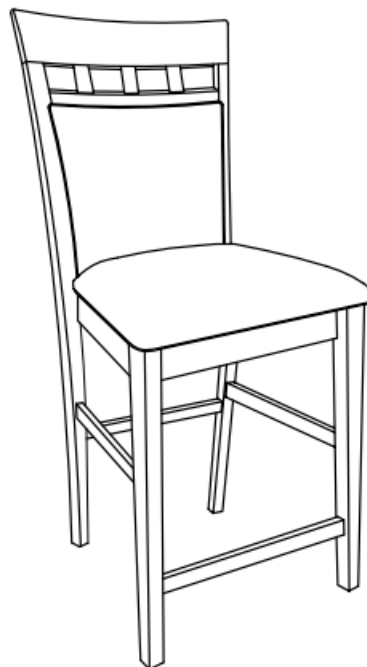

ITEM: **100219**

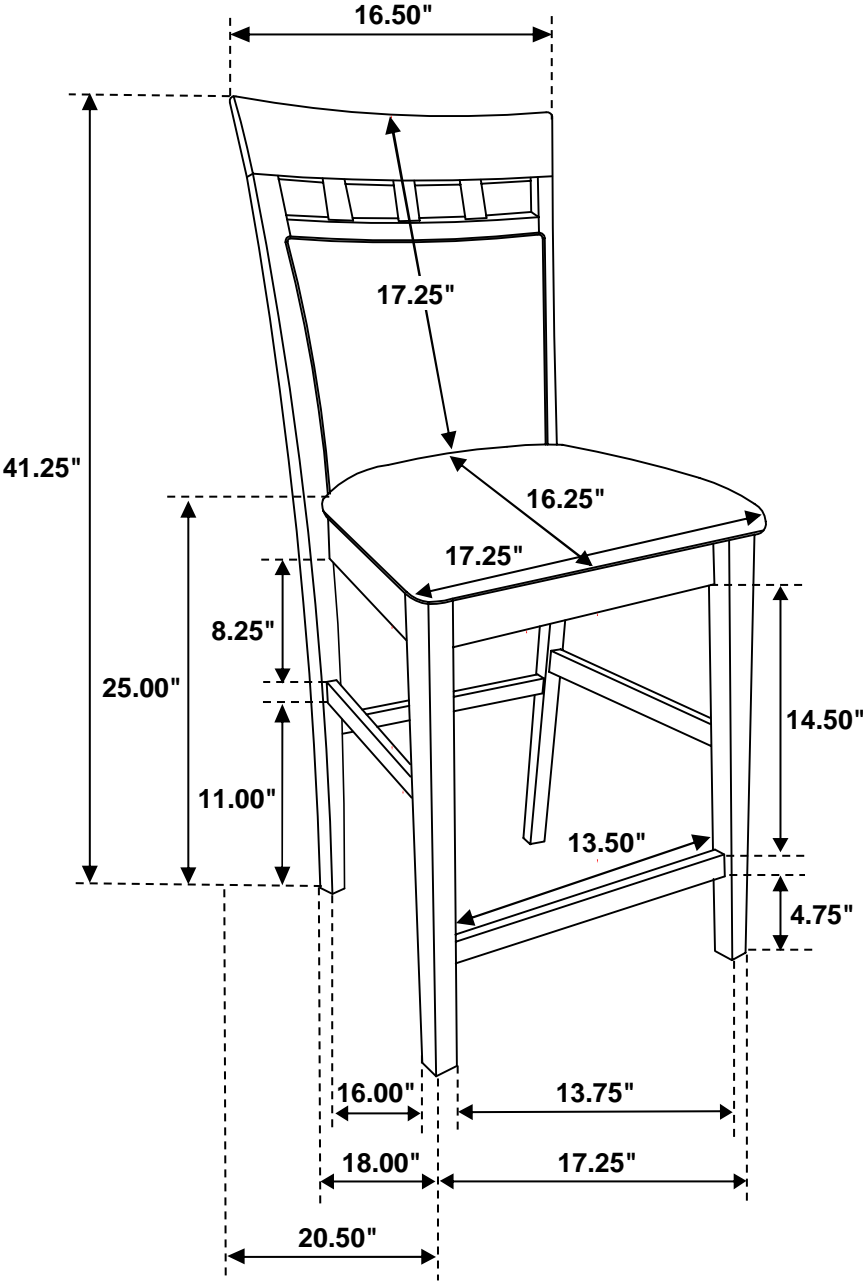

Note: Dimension tolerance  $\pm 5\%$