

ASSEMBLY INSTRUCTION

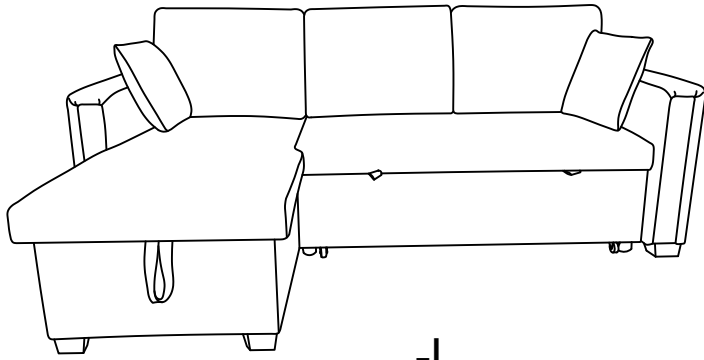

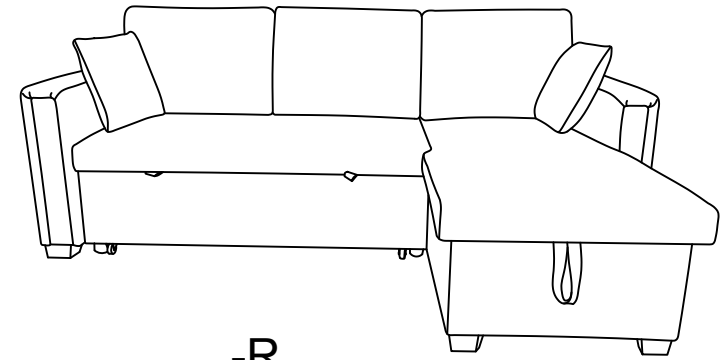

-L





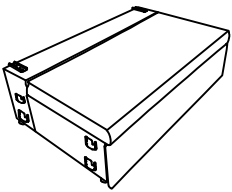
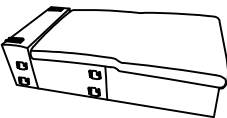
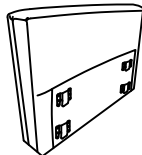
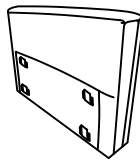
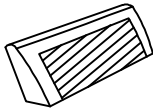
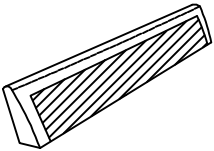

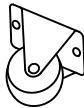
-R

PARTS LIST

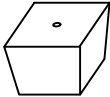
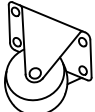
 A X1	 B X1	 C X1	 D X1	 E X1
 F X1	 G X3	 H X2	 9 40mmH parts have been assembled X2	

HARDWARE LIST

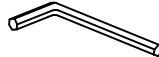
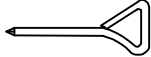
 1 Ø45*50mm X6	 2 90*90*50mm X6	 3 50mmH X2	 4 Ø5*25mm X8	 5 M8*55MM X6	 6 Ø16*Ø9 X6	 7 M5 X1	 8 X1
---	---	--	---	--	---	---	--

BOX -L HARDWARE LIST

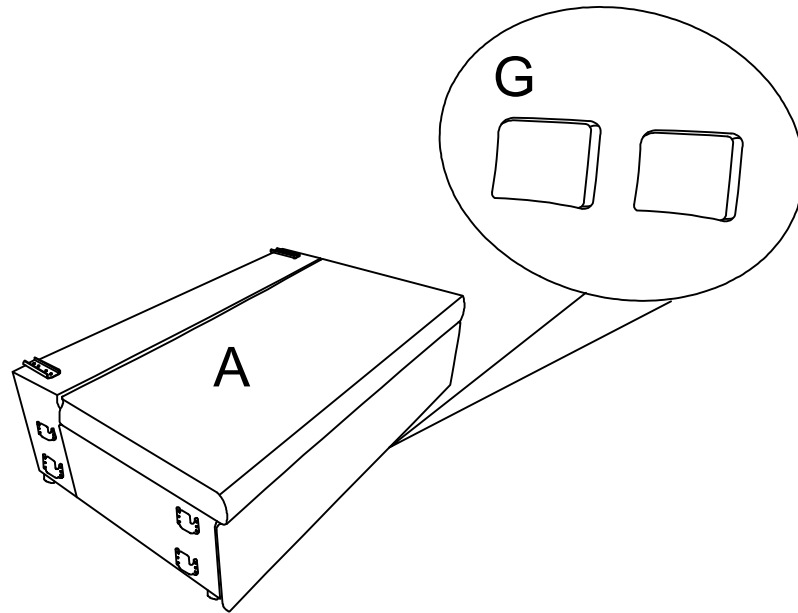

BOX -C HARDWARE LIST

①		X6	⑤		X6
②		X6	⑥		X6
③		X2	⑦		X1
④		X8	⑧		X1

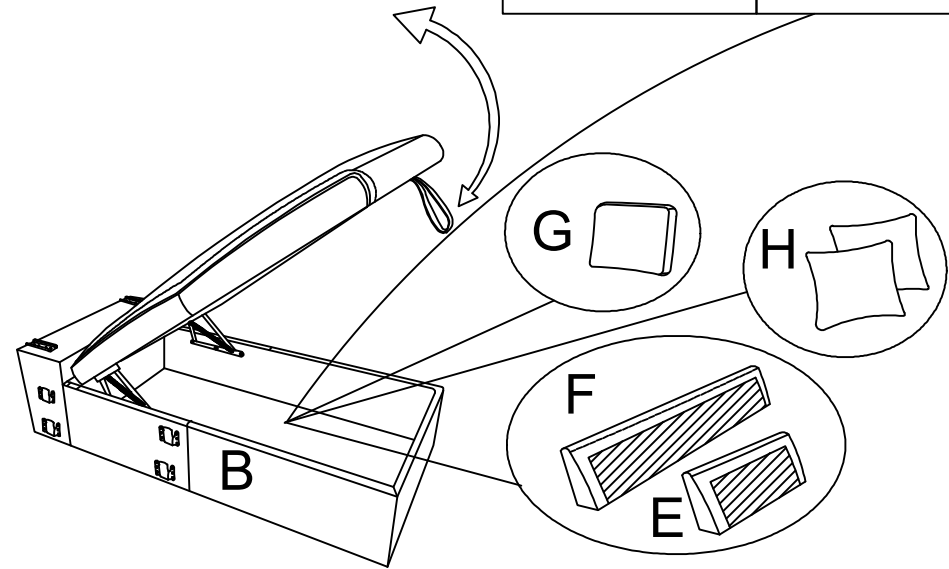

BOX -A HARDWARE LIST

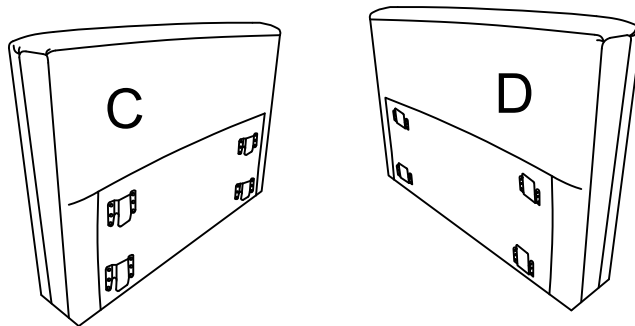

Unpacking steps:

1. BOX-C
2. BOX-L
3. BOX-A

STEP 1-L/R:

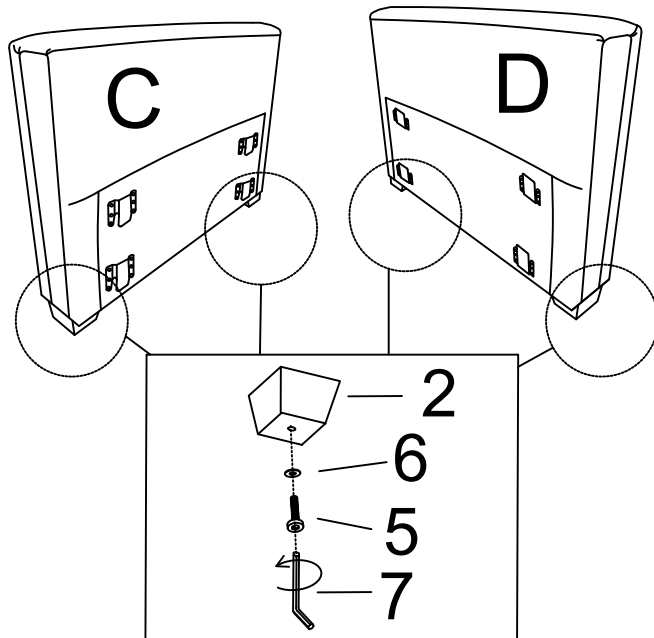
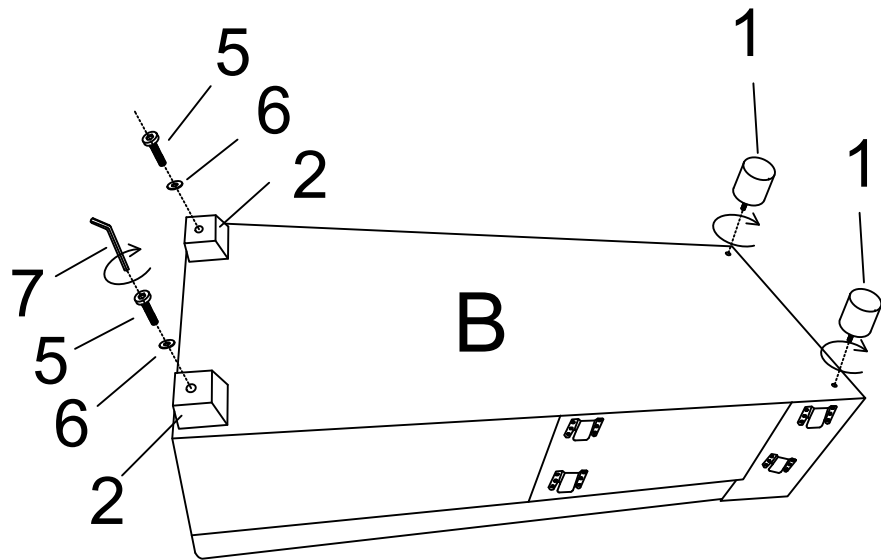

STEP 2-L/R:

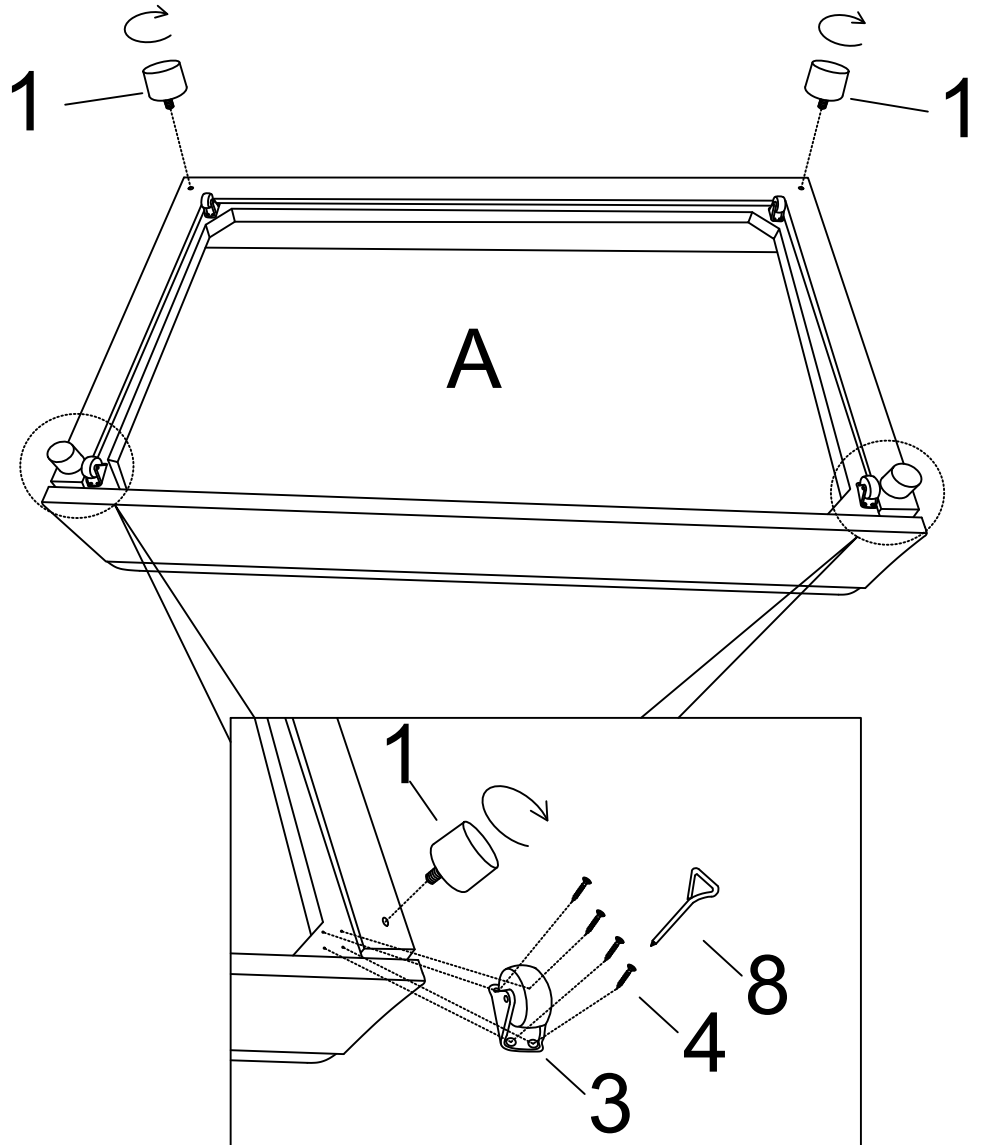

STEP 3-L/R:

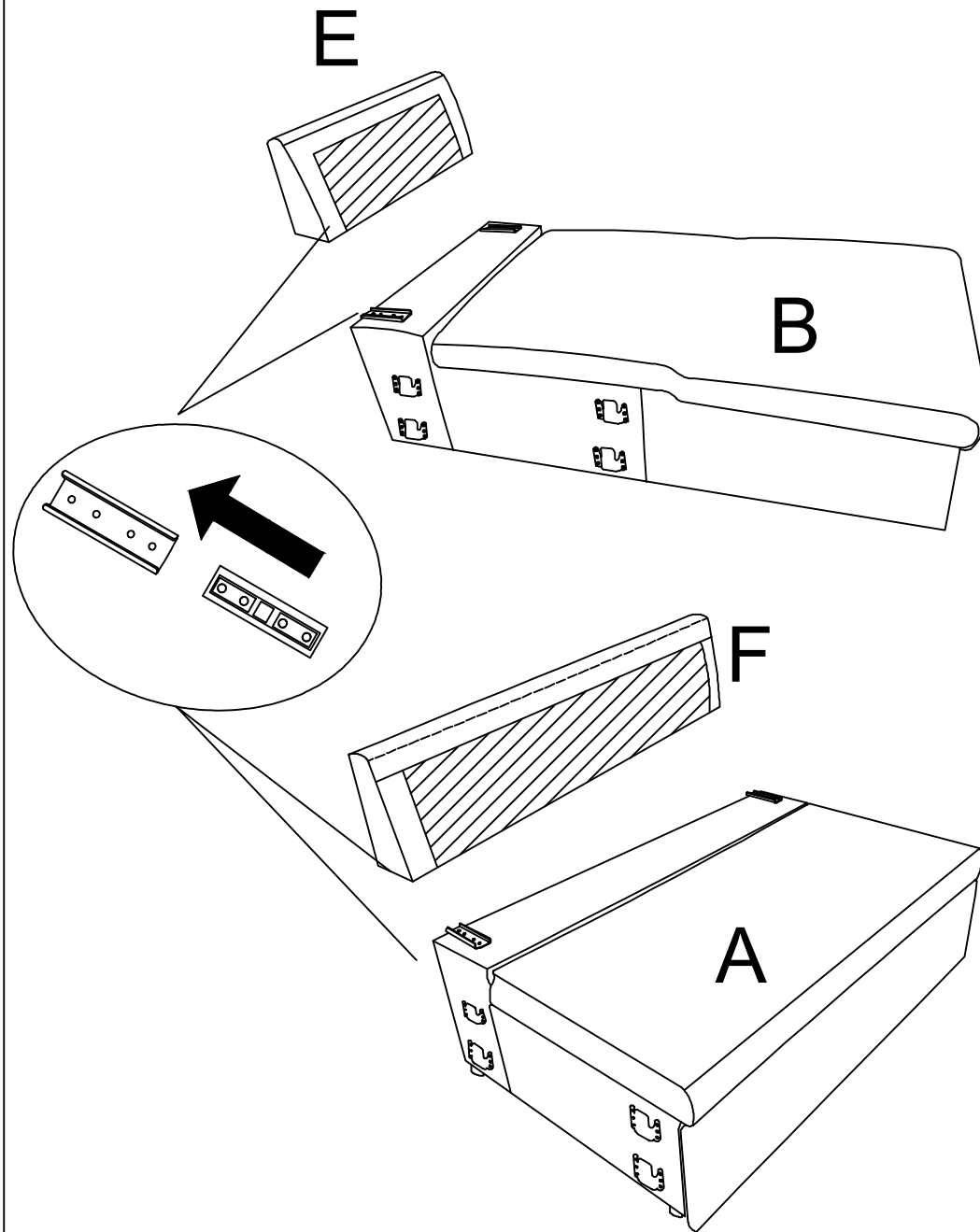

STEP 4-L:

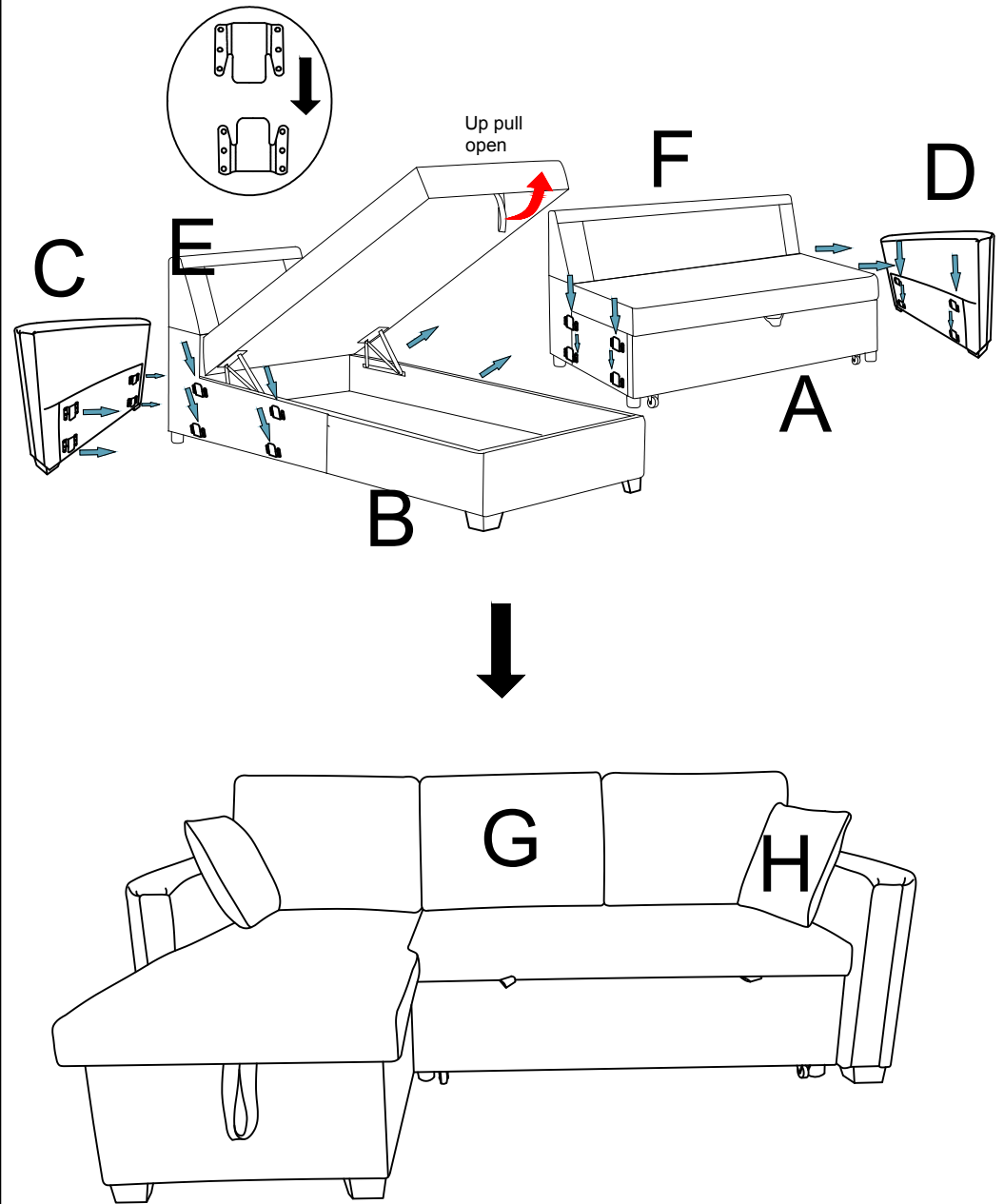

STEP 5-L:

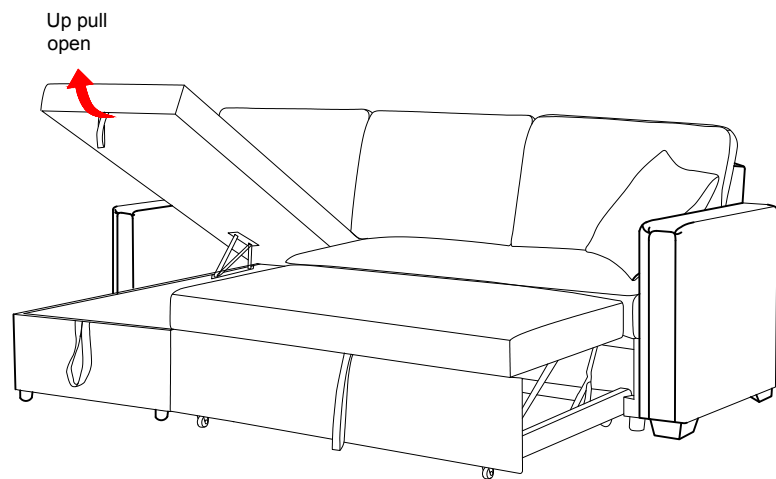
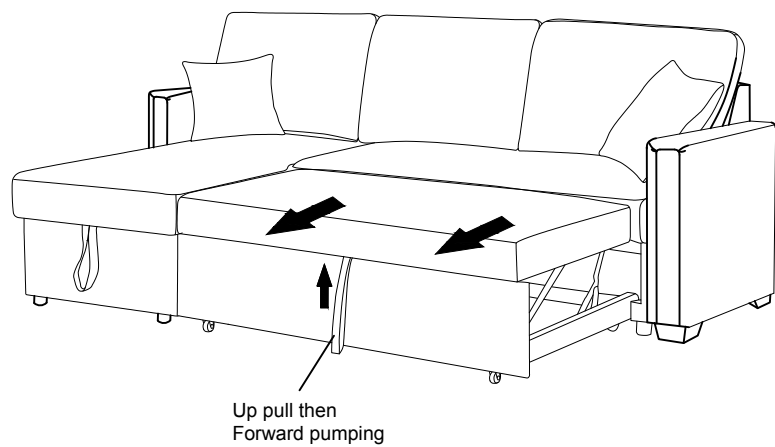

STEP 4-R:

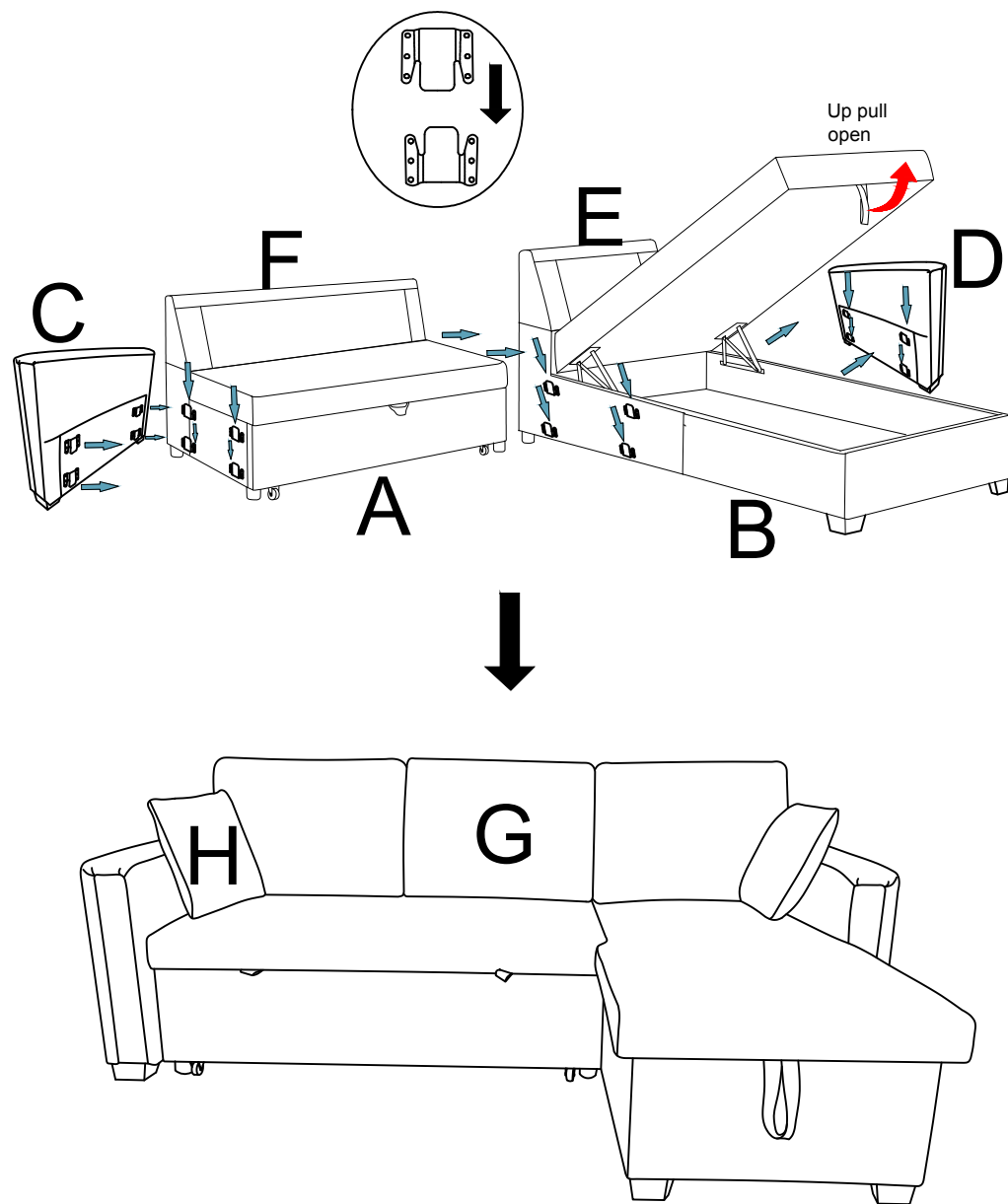

STEP 5-R:

