

Assembly Instructions

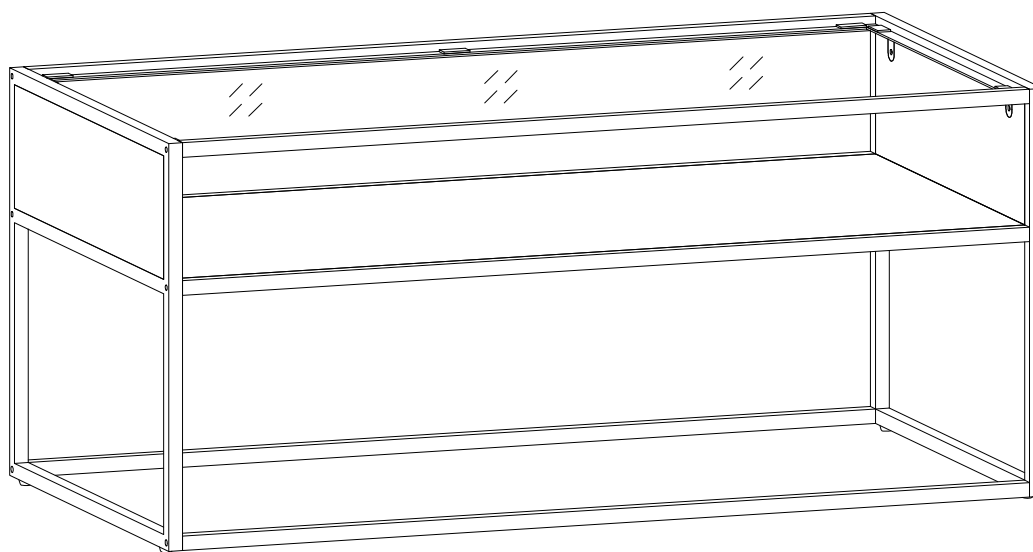

Please visit our website for the most current instructions, assembly tips, report damage, or request parts.

General Assembly Guidelines

- I. Ensure that all parts and hardware are available before beginning assembly.
- II. Follow each step carefully to ensure the proper assembly of this product.
- III. Two people are recommended for ease in the assembly of this product.
- IV. The two main types of hardware used to assemble this product are :
screws and bolts.
- V. A Phillips head screwdriver is required for the assembly of this product .

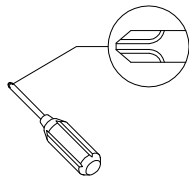



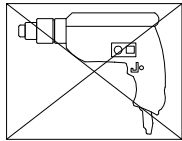

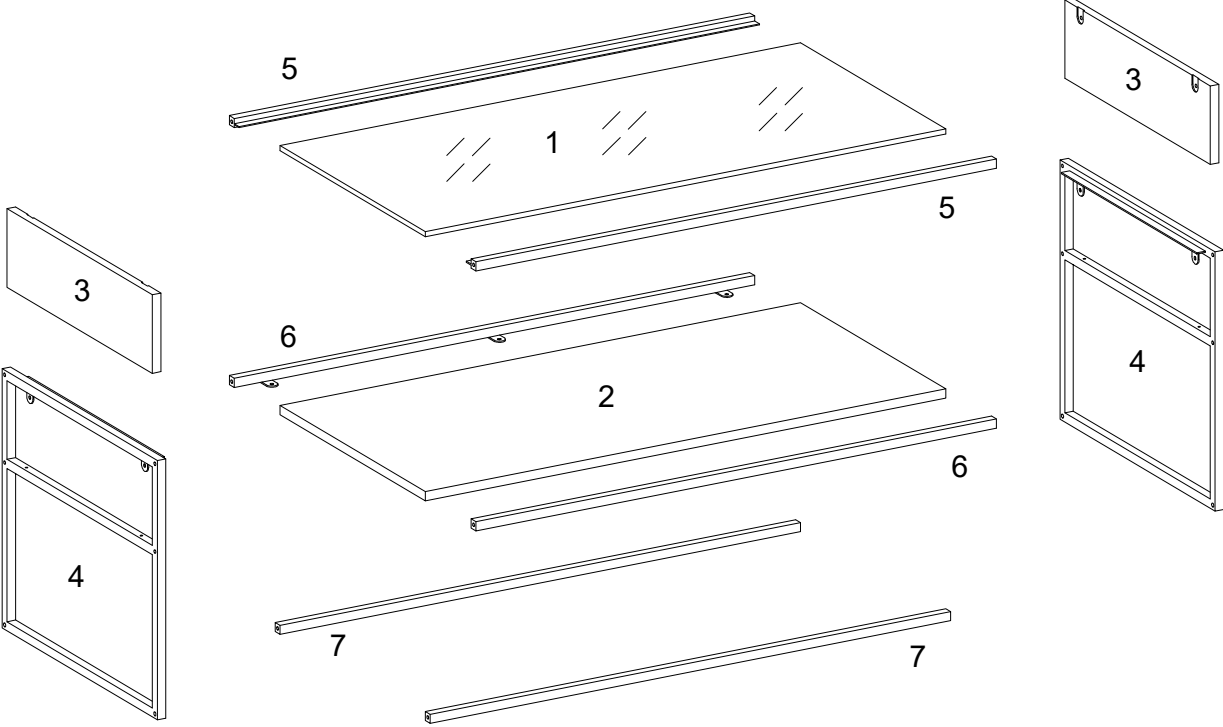

- VI. Power tools should not be used to assemble this product .



Parts List



Hardware List

A		Ø1/4"x30mm	Bolt	12 pcs
B		Ø1/4"x12mm	Bolt	10 pcs
C		Ø4x35mm	Screw	4 pcs
D		Ø16x1/4"	Adjuster	4 pcs
E		30x10mm	Glass pads	10 pcs
F		M 4	Hex Key	1 pc

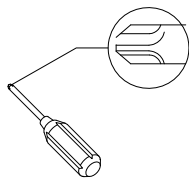

Philips head screwdriver required for assembly
(not included)

*The hardware quantities listed above are required for proper assembly.
Some extra hardware may also have been included.*

Step 1

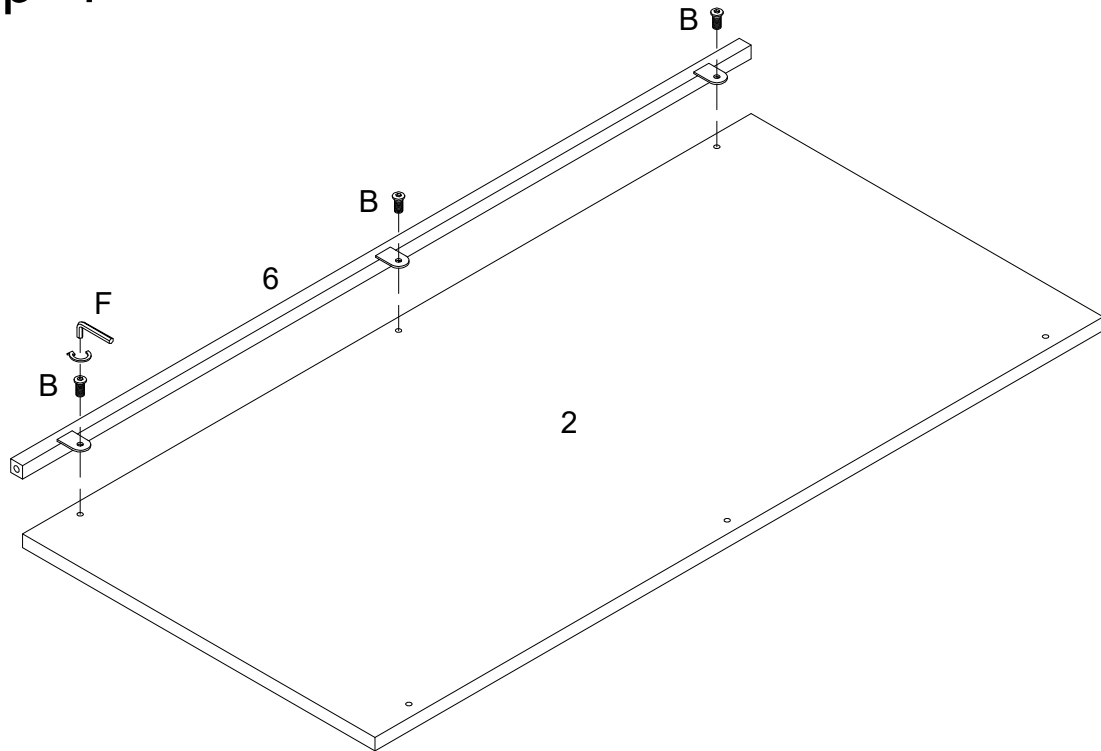

Attach part (6) to part (2) using bolt (B) with hex key (F).

Step 2

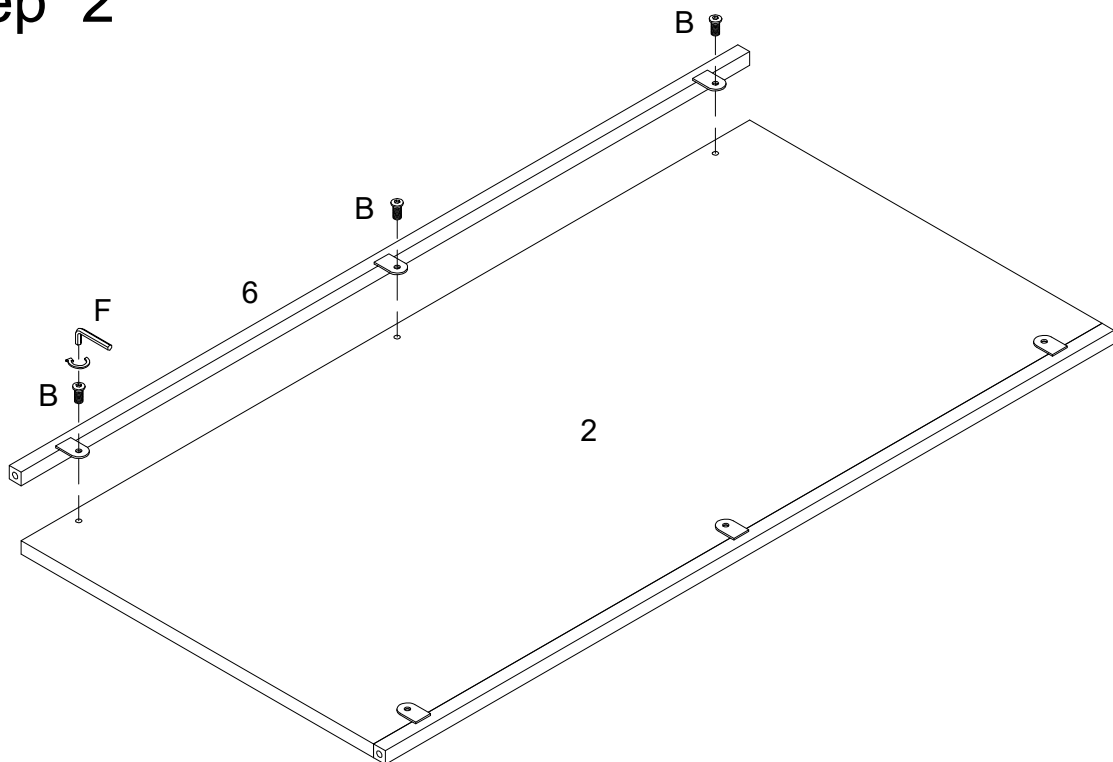

Attach part (6) to part (2) using bolt (B) with hex key (F).

Step 3

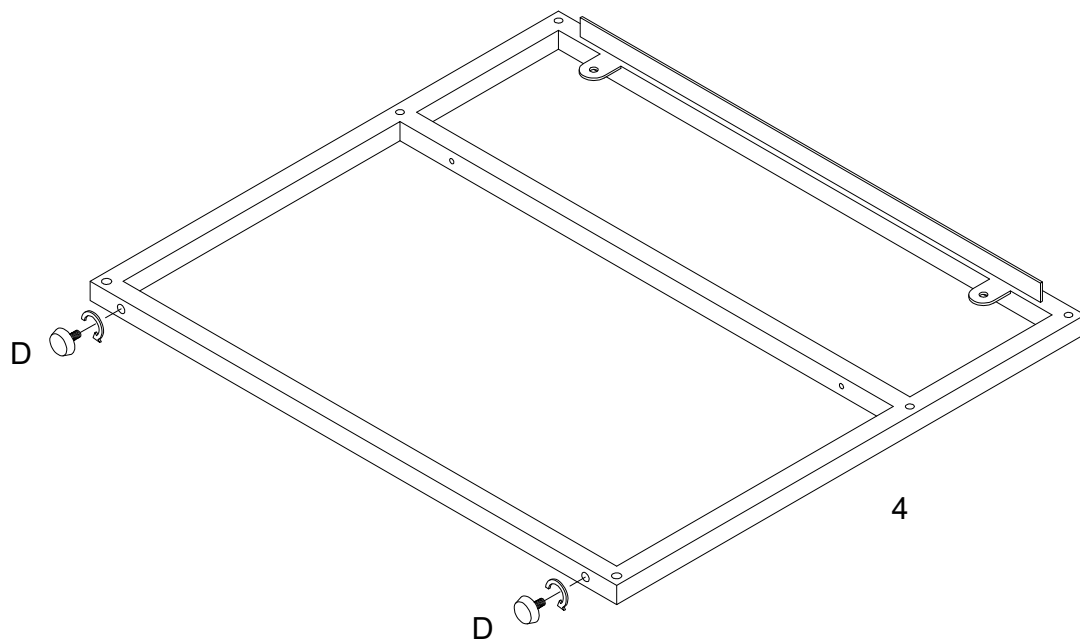

Attach adjuster (D) to part (4).

Step 4

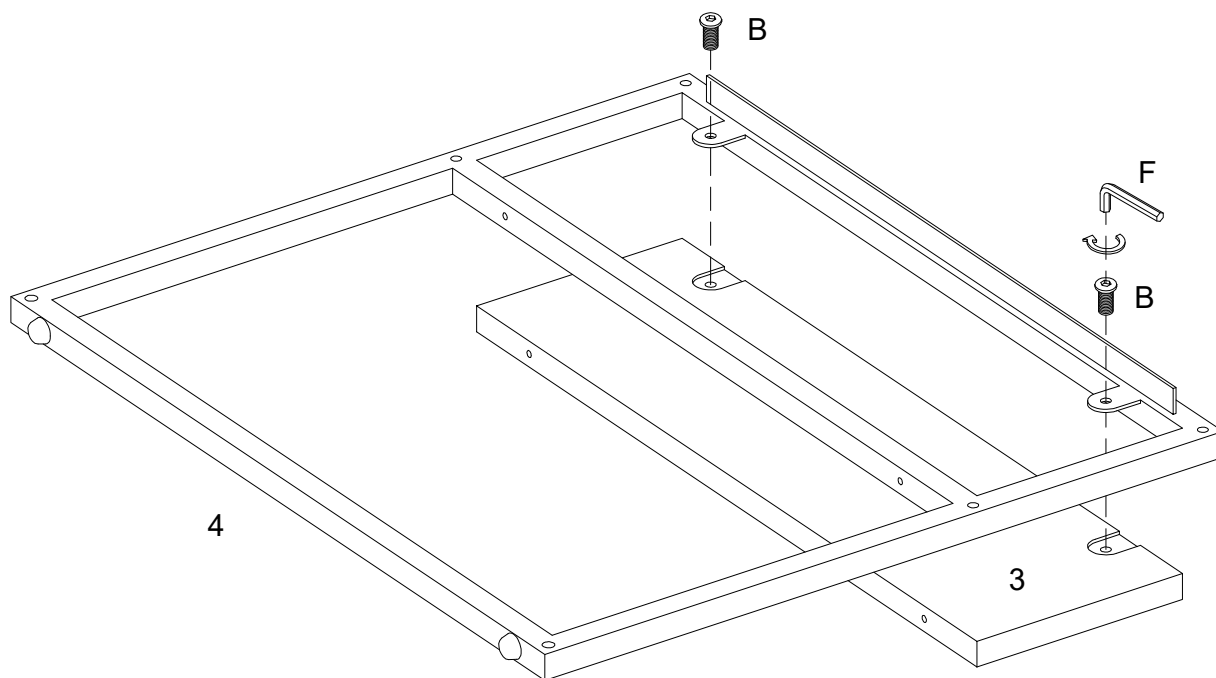

Attach part (4) to part (3) using bolt (B) with hex key (F).

Step 5

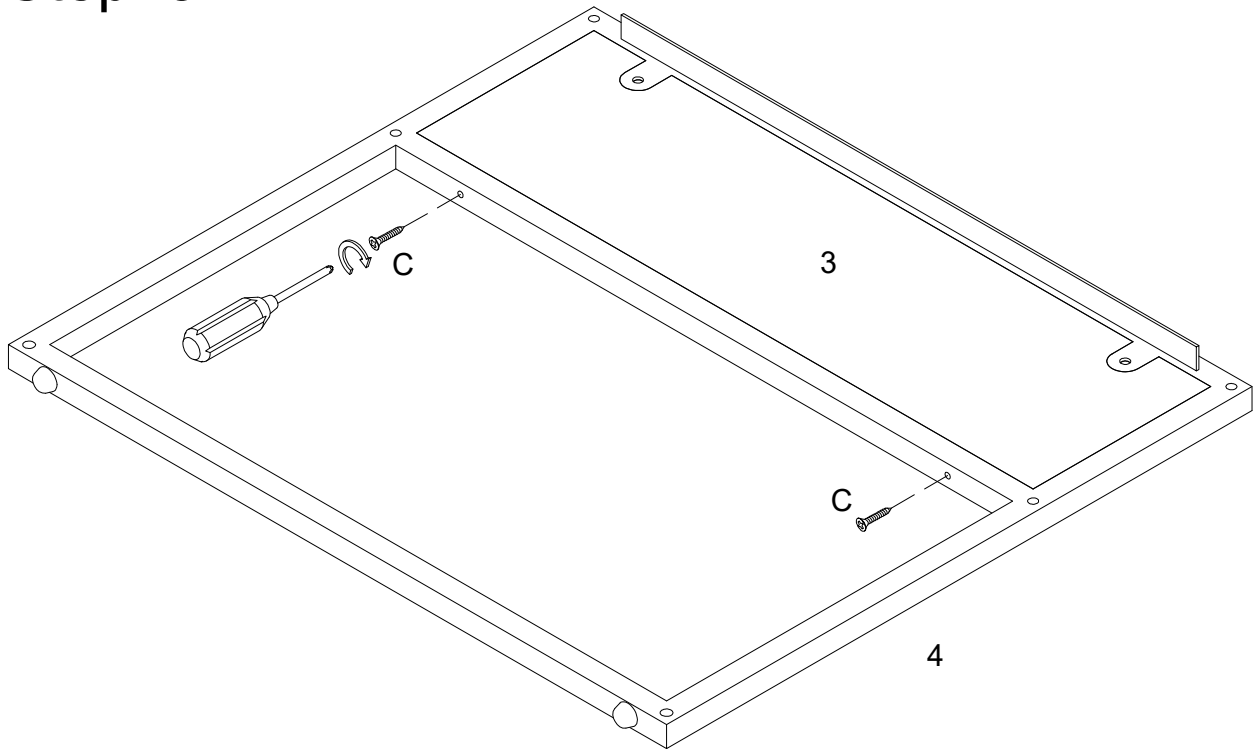

Attach part (4) to part (3) using screw (C) with screwdriver.

Step 6

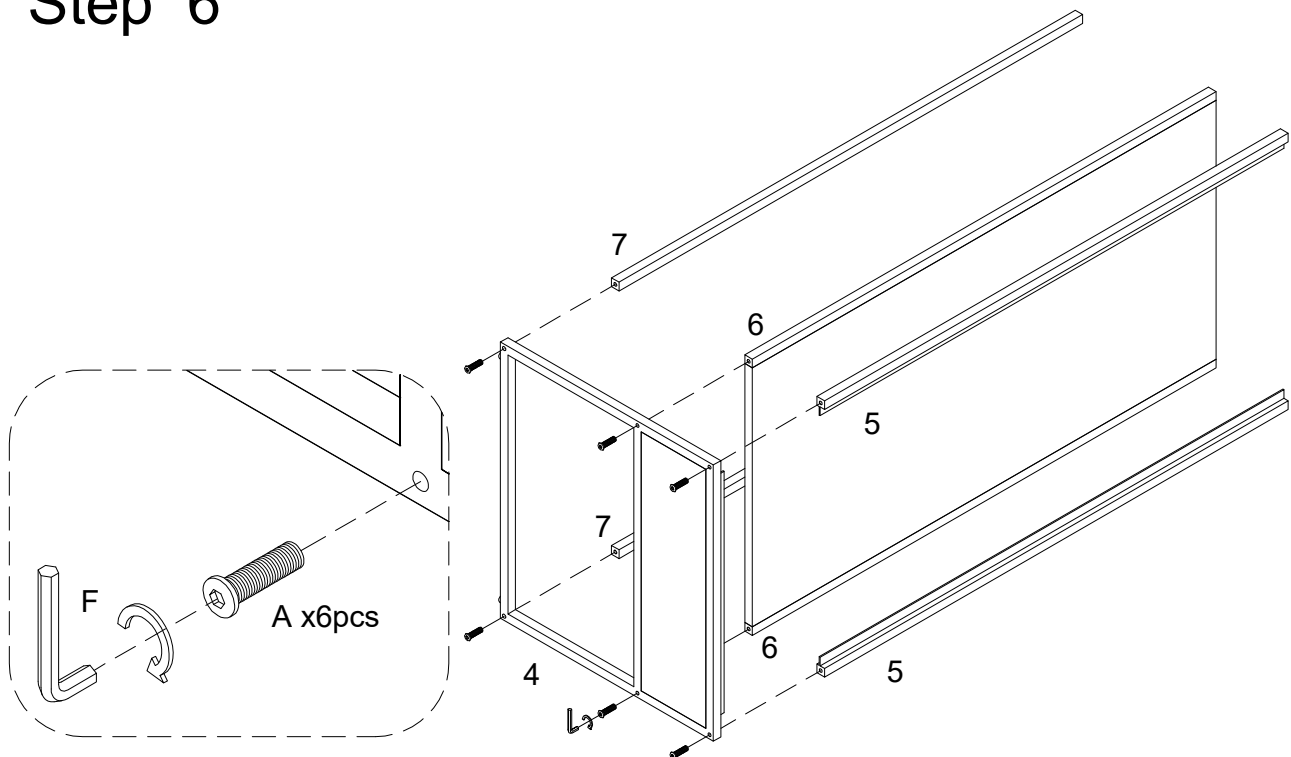

Attach part (4) to part (5,6,7) using bolt (A) with hex key (F).

Step 7

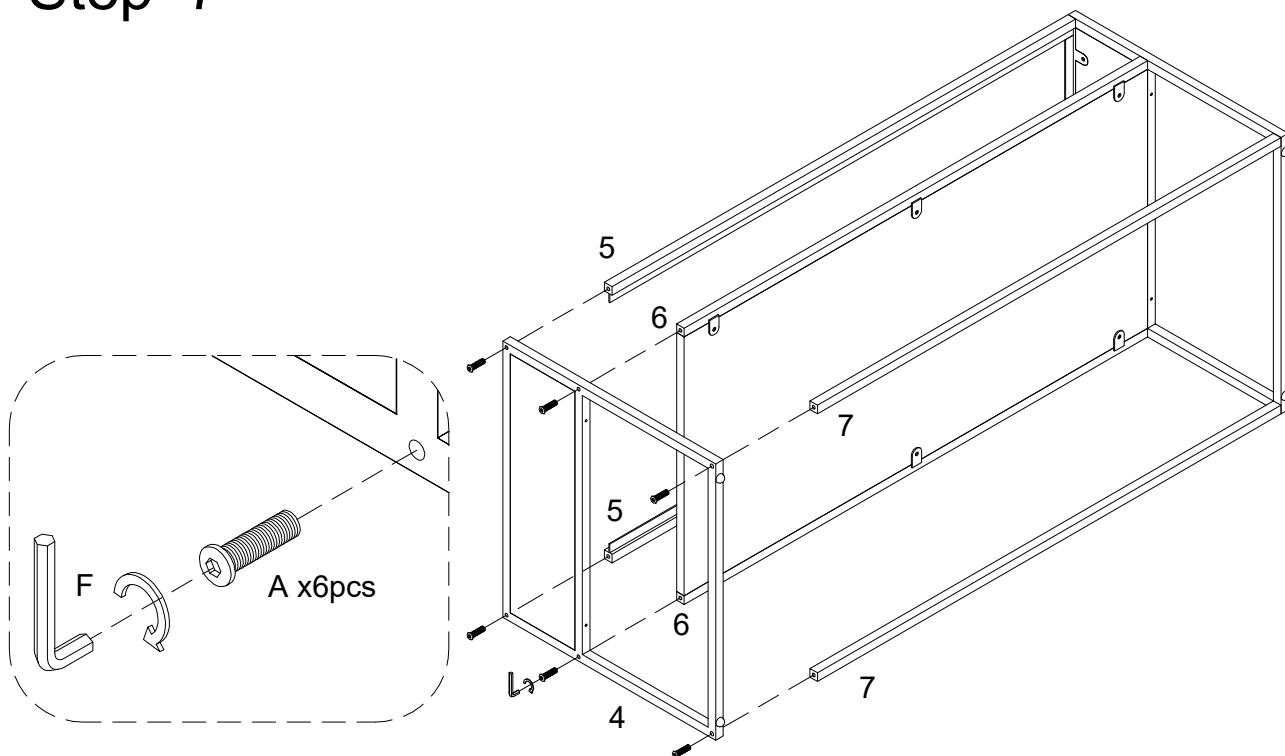

Attach part (4) to part (5,6,7) using bolt (A) with hex key (F).

Step 8

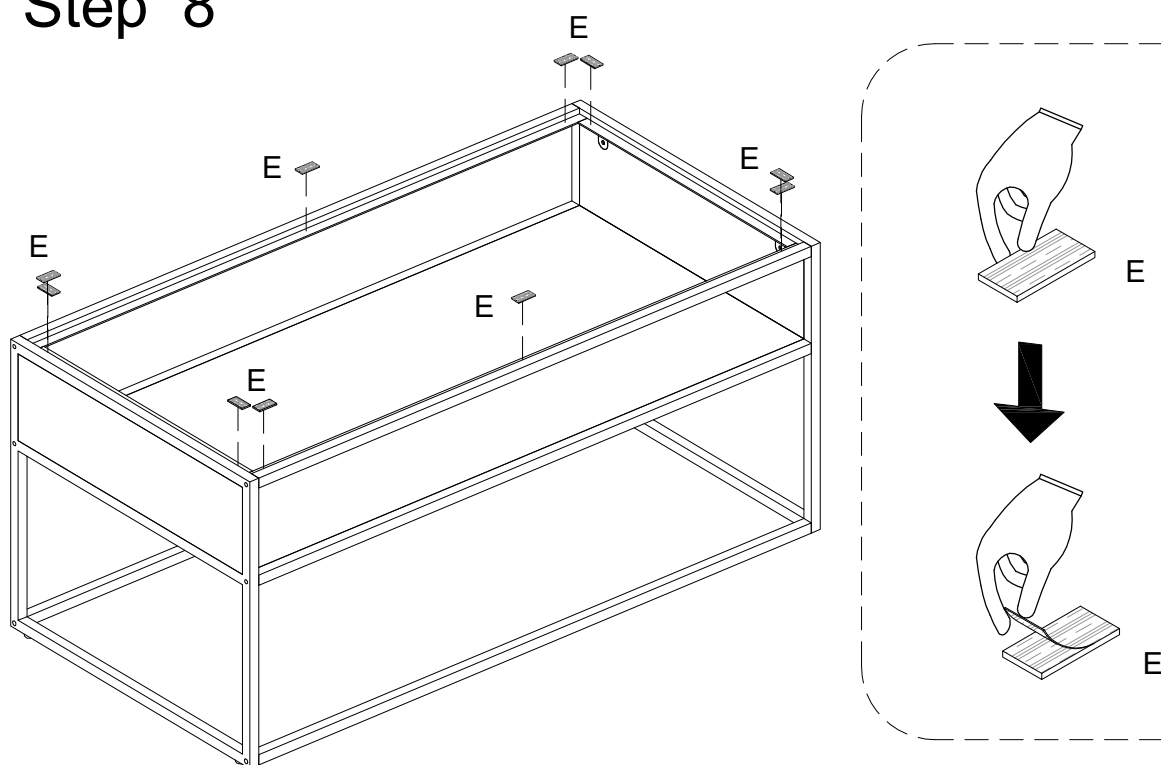

Remove cover tape on glass pads (E), then stick it as diagram.

Step 9

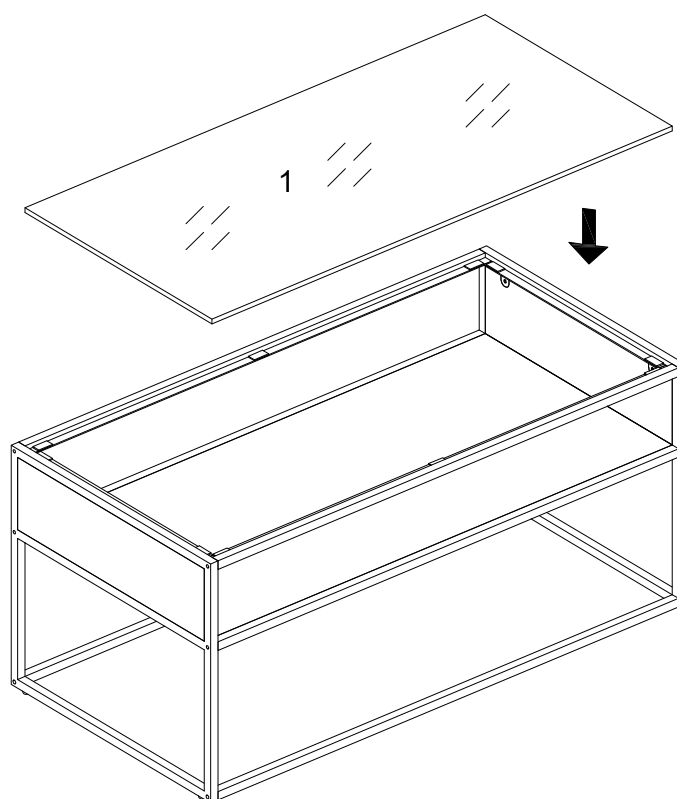

Place Glass (1) into frame carefully as per diagram.

Step 10

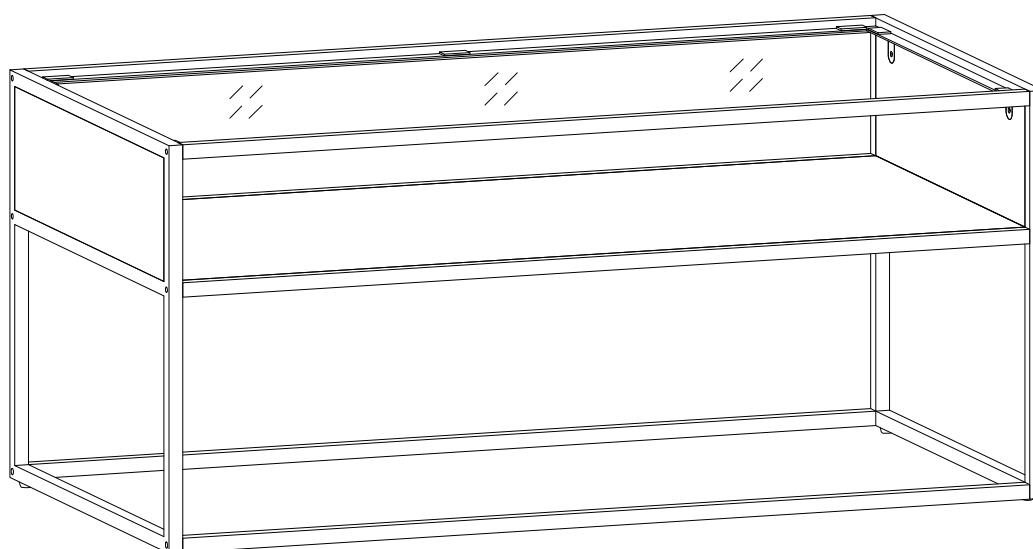

Final Assembly