

Assembly Instructions

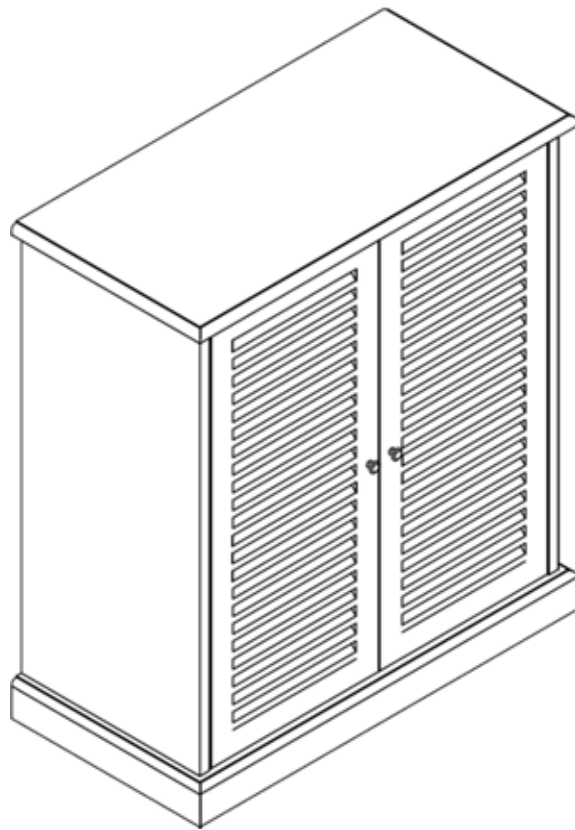

ASSEMBLY RATING

The Assembly Rating is a 5-point system that shows the degree of effort needed in assembling a specific product (with 1 being easy and 5 being difficult). For some products, two persons are recommended.

EASY  DIFFICULT

Tools Required for Assembly:

Allen Wrench

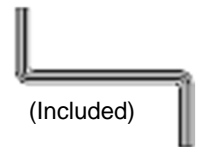

(Included)

Phillips Screwdriver



(Not Included)

Flat-Head Screwdriver



(Not Included)





Before you begin, please read Page 2 of "Assembly and Care Advice".







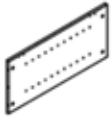
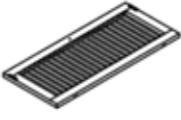
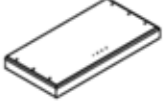
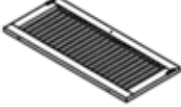
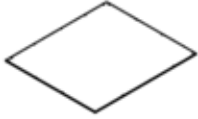



And remember, do not tighten until each step is completed or instructed.

MD

Parts List

1	TOP PANEL		1PC	5	SHELF		4PCS
2	SIDE PANEL/LEFT		2PCS	6	LEFT DOOR		1PC
3	BOTTOM PANEL		1PC	7	RIGHT DOOR		1PC
4	BACK PANEL		1PC				

Hardware List

A	CAM-BOLT(Ø8mm)		8PCS	G	SCREWS(3*14mm)		16PCS
B	CAM-LOCK(Ø15mm)		8PCS	H	WOOD DOWEL(Ø8*30mm)		4PCS
C	HANDLE(Ø18)		1PC	I	SCREWS(3*16mm)		18PCS
D	HANDLE BOLT(5/32**1")		1PC	J	GLUE		1PC
E	SUPPORT(Ø6.2mm)		16PCS	K	ALLEN WRENCH		1PC
F	MAGNET		4PCS				

CAM LOCK FASTENER ASSEMBLY INSTRUCTIONS

Note: Every cam lock bolt must have a cam lock connector in order to fasten the parts together.

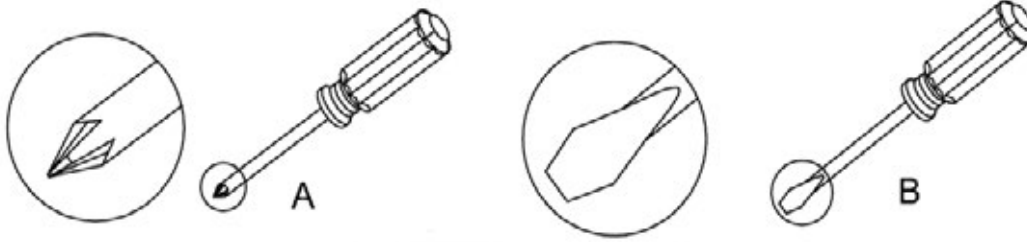

(1) Secure the threaded end of the cam bolt by using a screwdriver.

Turn right (clockwise) to tighten

Align the cam connector with its side opening (or arrow) pointing to the small drilled hole.

(2) Insert the cam lock bolt into the pre-drilled hole above the cam connector.

(3) Two parts should fit snugly against each other.

(4) Turn the cam connector with a screwdriver until it will not turn any more with light to moderate force.

Turn right (clockwise) to tighten

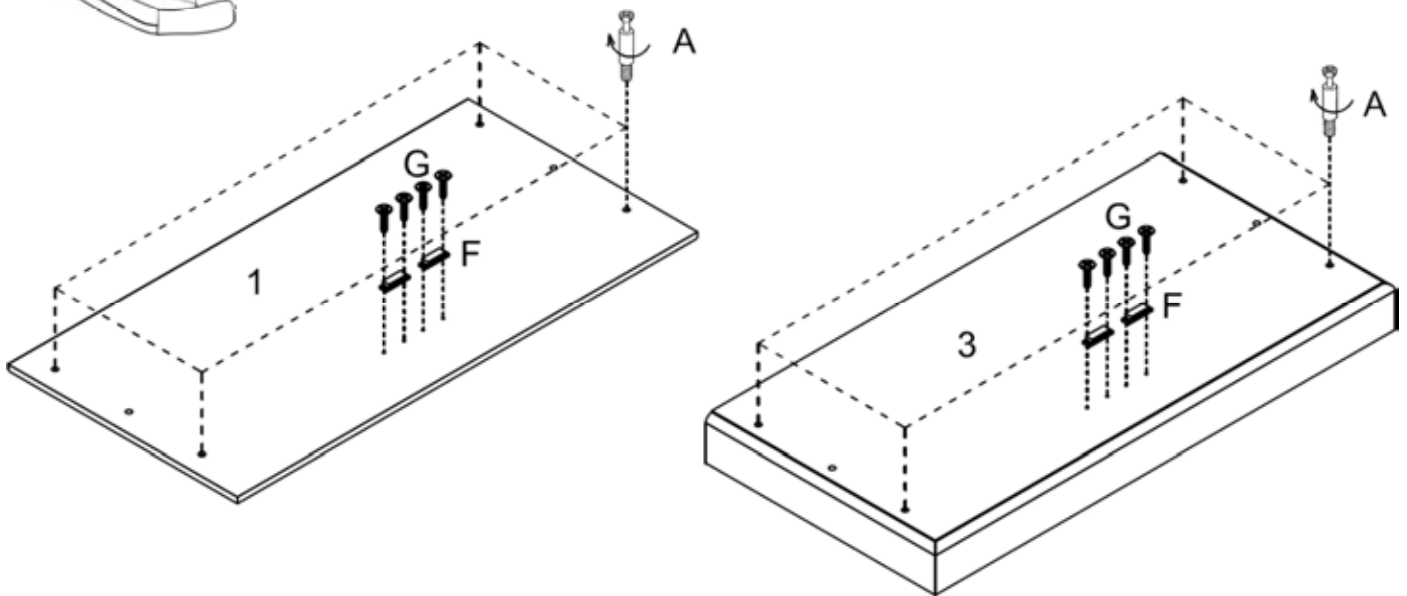

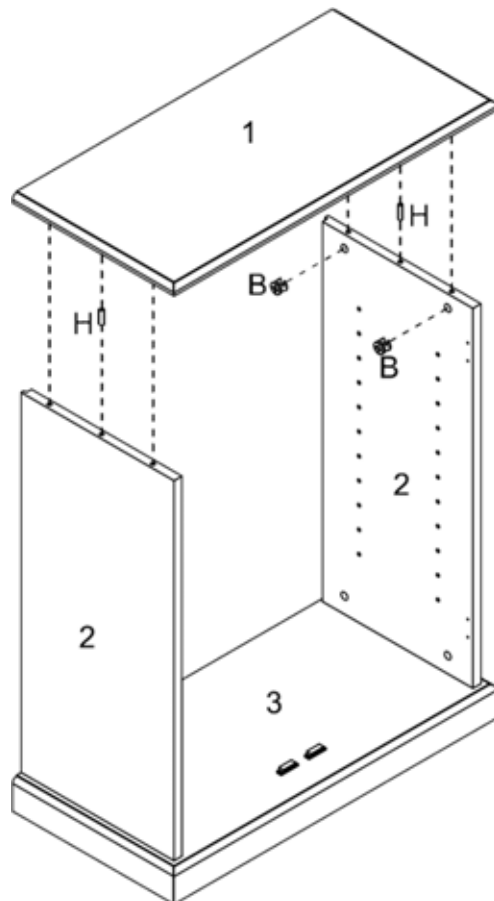
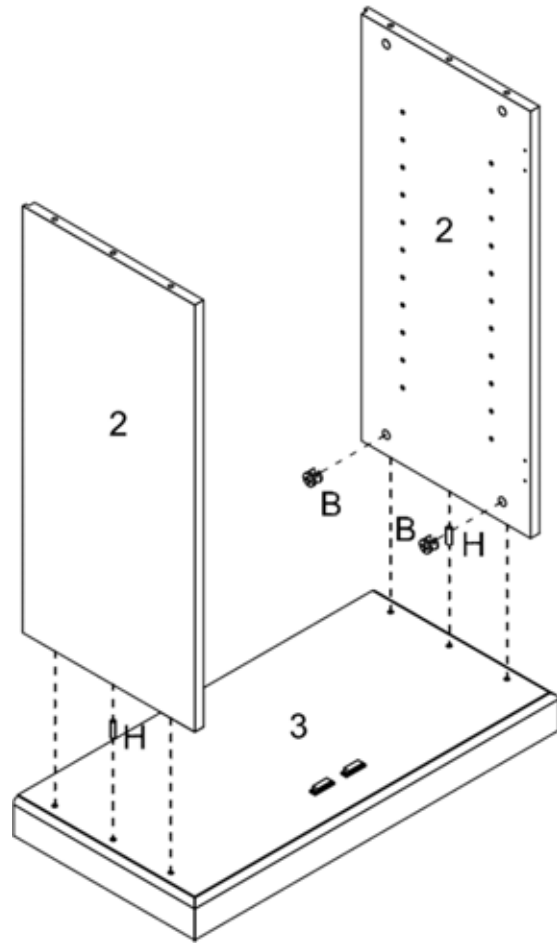

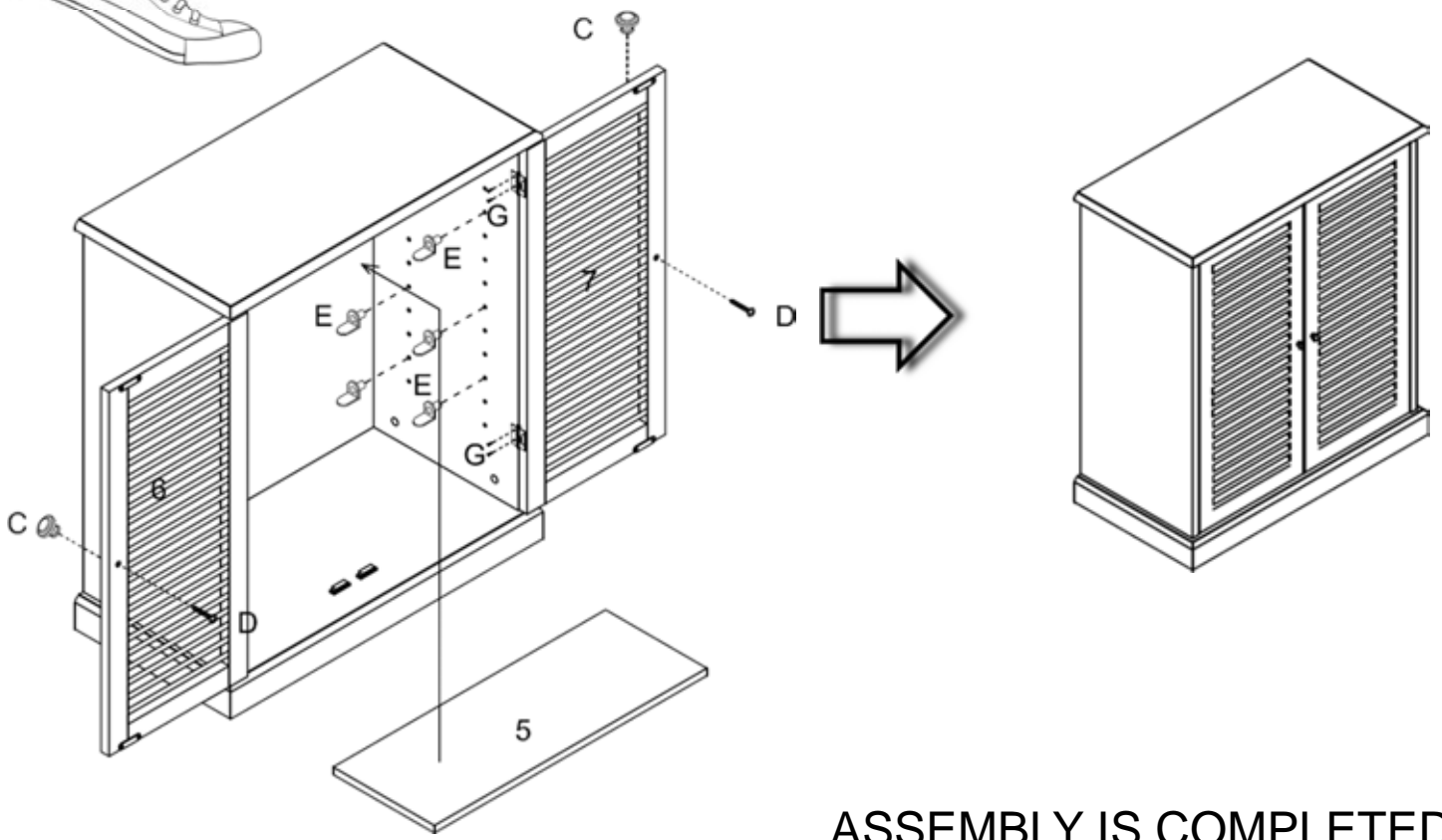
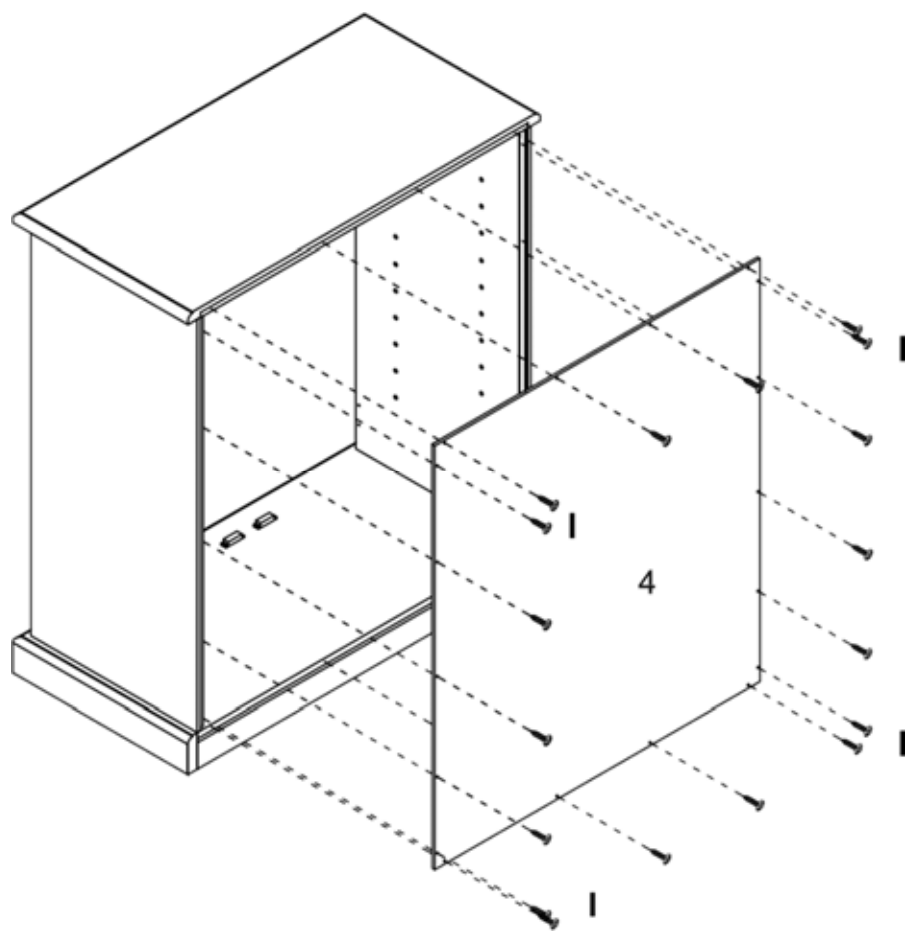

ASSEMBLY IS COMPLETED