

**Cabinet
Meuble
Armario**

To receive free replacement, a Proof-of-Purchase from an authorized dealer/retailer and the Control number above MUST be provided with request. Free replacement within 60 days from date of purchase.

Pour recevoir un remplacement gratuit, une preuve d'achat d'un détaillant autorisé et le numéro de contrôle ci-dessus DOIVENT être fournis avec la demande. Remplacement gratuit dans les 60 jours suivant la date d'achat.

Para recibir un reemplazo gratuito, se DEBE proporcionar un comprobante de compra de un minorista autorizado y el número de control anterior con el reclamo. Reemplazo gratuito dentro de los 60 días a partir de la fecha de compra.

IMPORTANT! Control No. is required to ensure parts will fit.

IMPORTANT! Le numéro de contrôle est nécessaire pour s'assurer que les pièces s'adaptent.

¡IMPORTANTE! El número de control es necesario para garantizar que las piezas se ajusten.

Missing parts request:

To obtain replacement part(s), fill in quantity in the "missing" box under the "Parts List" section. Complete contact and shipping information in address box accurately and clearly. Please allow 7-14 days for delivery.

Demande de pièces manquantes:

Pour obtenir une (des) pièce(s) de remplacement, remplissez la case « manquant » sous la section « Liste des pièces ». Fournissez vos coordonnées et informations d'expédition dans la case Adresse de manière claire et précise. La livraison aura lieu dans un délai de 7 à 14 jours.

Petición de partes perdidas:

Para obtener parte(s) de reemplazo, llené en número la cantidad en el cuadro de "missing" debajo de "Lista de partes" sección. Llené su información de contacto y envío en el cuadro de dirección clara y correcta. Por favor permita 7-14 días para envío.

Parts List - Liste des pièces - Lista de partes

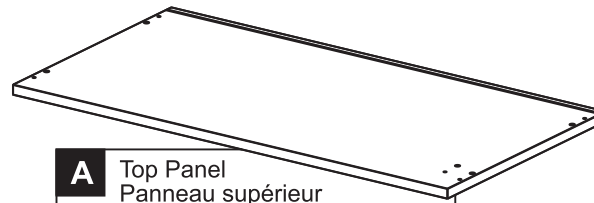

A	Top Panel Panneau supérieur Tapa			
Quantity Quantité Cantidad	1	Replace Remplacer Reemplazar		

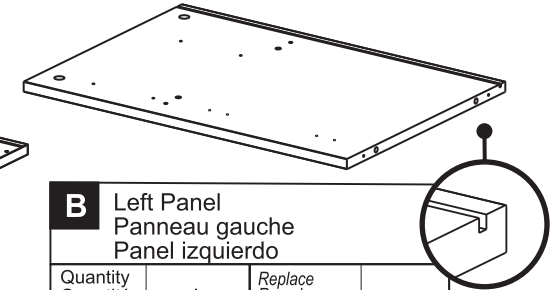

B	Left Panel Panneau gauche Panel izquierdo			
Quantity Quantité Cantidad	1	Replace Remplacer Reemplazar		

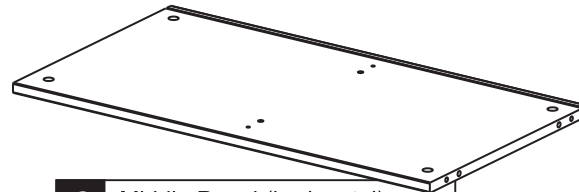

C	Middle Panel (horizontal) Panneau du milieu (horizontal) Panel de en medio (horizontal)			
Quantity Quantité Cantidad	1	Replace Remplacer Reemplazar		

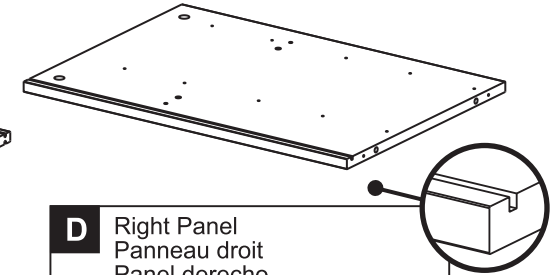

D	Right Panel Panneau droit Panel derecho			
Quantity Quantité Cantidad	1	Replace Remplacer Reemplazar		

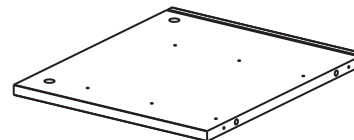

E	Middle Panel (vertical) Panneau du milieu (verticale) Panel de en medio (vertical)			
Quantity Quantité Cantidad	1	Replace Remplacer Reemplazar		

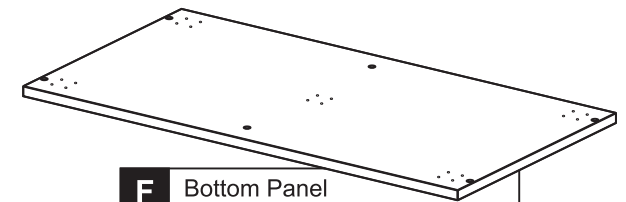

F	Bottom Panel Panneau inférieur Panel de abajo			
Quantity Quantité Cantidad	1	Replace Remplacer Reemplazar		

Name - Nom - Nombre

Address - Adresse - Dirección

City/State/Zip - Ville/Province/Code postal - Ciudad/Estado/Zona Postal

Phone - Téléphone - Teléfono

Email

Reason of replacement/Raison de remplacement/Razón del reemplazo

- Missing/Manquant/Ausente
- Damaged/Endommagé/Dañado
- Not Fit/Ne rentre pas/No ajusta
- Other, explain/Autre, expliquer/Otro, explicar

Name - Nom - Nombre

Address - Adresse - Dirección

City/State/Zip - Ville/Province/Code postal - Ciudad/Estado/Zona Postal

Phone - Téléphone - Teléfono

Email

Reason of replacement/Raison de remplacement/Razón del reemplazo

- Missing/Manquant/Ausente
 Damaged/Endommagé/Dañado
 Not Fit/Ne rentre pas/No ajusta
 Other, explain/Autre, expliquer/Otro, explicar

IMPORTANT! Control No. is required to ensure parts will fit.

IMPORTANT! Le numéro de contrôle est nécessaire pour s'assurer que les pièces s'adaptent.

¡IMPORTANTE! El número de control es necesario para garantizar que las piezas se ajusten.

Parts List - Liste des pièces - Lista de partes

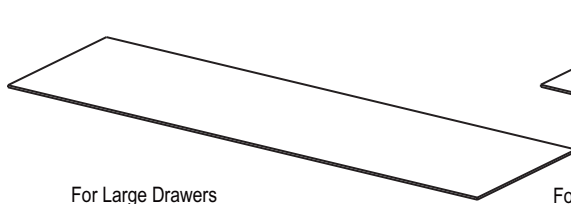

For Large Drawers
Pour les grands tiroirs
Par cajones grandes

G	Back Panel (Upper) Panneau arrière (supérieure) Panel de atrás (de arriba)		
Quantity Quantité Cantidad	1	Replace Remplacer Reemplazar	

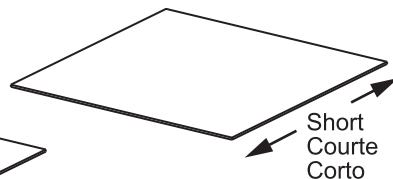

For Door
Pour porte
Para puerta

14.09 in (35.8 cm)

H1	Back Panel (Lower-Left) Panneau arrière (inférieure-gauche) Panel de atrás (de abajo-izquierdo)		
Quantity Quantité Cantidad	1	Replace Remplacer Reemplazar	

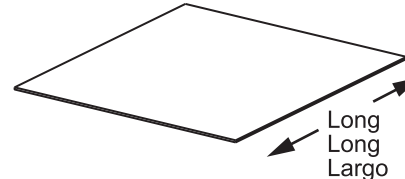

For Small Drawers
Pour les petits tiroirs
Par cajones pequeños

15.5 in (39.4 cm)

H2	Back Panel (Lower-Right) Panneau arrière (inférieure-droit) Panel de atrás (de abajo/derecho)		
Quantity Quantité Cantidad	1	Replace Remplacer Reemplazar	

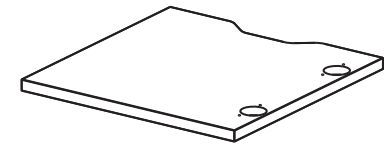

I	Door Porte Puerta		
Quantity Quantité Cantidad	1	Replace Remplacer Reemplazar	

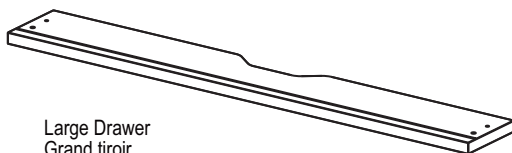

Large Drawer
Grand tiroir
Cajón grande

J	Front Panel (Drawer) Panneau avant (tiroir) Panel de enfrente (cajón)		
Quantity Quantité Cantidad	2	Replace Remplacer Reemplazar	

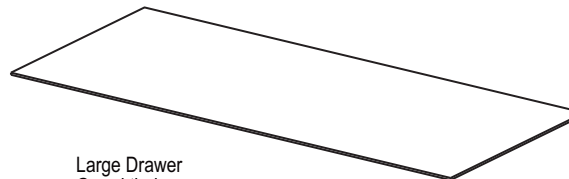

Large Drawer
Grand tiroir
Cajón grande

K	Bottom Board (Drawer) Conseil inférieur (tiroir) Base de abajo (cajón)		
Quantity Quantité Cantidad	2	Replace Remplacer Reemplazar	

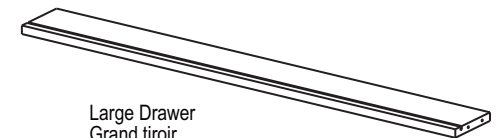

Large Drawer
Grand tiroir
Cajón grande

L	Back Panel (Drawer) Panneau arrière (tiroir) Panel de atrás (cajón)		
Quantity Quantité Cantidad	2	Replace Remplacer Reemplazar	

Reason of replacement/Raison de remplacement/Razón del reemplazo

- Missing/Manquant/Ausente
- Damaged/Endommagé/Dañado
- Not Fit/Ne rentre pas/No ajusta
- Other, explain/Autre, expliquer/Otro, explicar

IMPORTANT! Control No. is required to ensure parts will fit.

IMPORTANT! Le numéro de contrôle est nécessaire pour s'assurer que les pièces s'adaptent.

¡IMPORTANTE! El número de control es necesario para garantizar que las piezas se ajusten.

Name - Nom - Nombre

Address - Adresse - Dirección

City/State/Zip - Ville/Province/Code postal - Ciudad/Estado/Zona Postal

Phone - Téléphone - Teléfono

Email

Parts List - Liste des pièces - Lista de partes



Small Drawer
Petit tiroir
Cajón pequeño

M	Front Panel (Drawer) Panneau avant (tiroir) Panel de enfrente (cajón)			
Quantity Quantité Cantidad	3	Replace Remplacer Reemplazar		

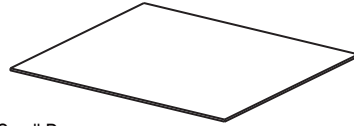

Small Drawer
Petit tiroir
Cajón pequeño

N	Bottom Board (Drawer) Conseil inférieur (tiroir) Base de abajo (cajón)			
Quantity Quantité Cantidad	3	Replace Remplacer Reemplazar		

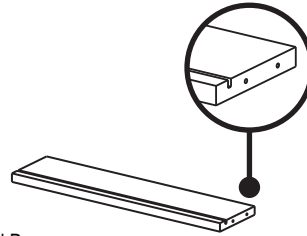

Small Drawer
Petit tiroir
Cajón pequeño

O	Back Panel (Drawer) Panneau arrière (tiroir) Panel de atrás (cajón)			
Quantity Quantité Cantidad	3	Replace Remplacer Reemplazar		

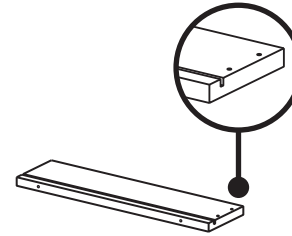

P	Left Panel (Drawer) Panneau gauche (tiroir) Panel izquierdo (cajón)			
Quantity Quantité Cantidad	5	Replace Remplacer Reemplazar		

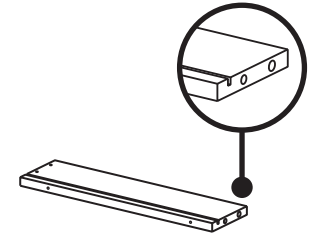

Q	Right Panel (Drawer) Panneau droit (tiroir) Panel derecho (cajón)			
Quantity Quantité Cantidad	5	Replace Remplacer Reemplazar		

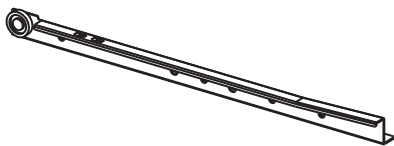

R	Drawer Rail (Left) Glissière de tiroir (gauche) Brasadera (izquierda)			
Quantity Quantité Cantidad	5	Replace Remplacer Reemplazar		

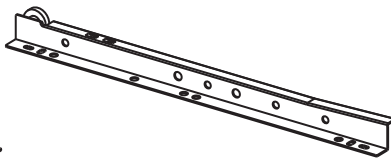

S	Drawer Rail (Right) Glissière de tiroir (droite) Brasadera (derecha)			
Quantity Quantité Cantidad	5	Replace Remplacer Reemplazar		

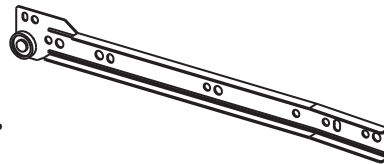

T	Drawer Guide (Left) Coulisse à tiroir (gauche) Pista de cajón (izquierdo)			
Quantity Quantité Cantidad	5	Replace Remplacer Reemplazar		

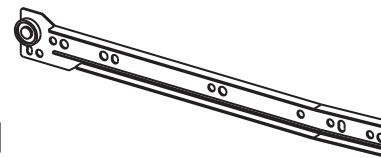

U	Drawer Guide (Right) Coulisse à tiroir (droit) Pista de cajón (derecho)			
Quantity Quantité Cantidad	5	Replace Remplacer Reemplazar		

For Drawer Guide
Pour coulisse à tiroir
Para pista de cajón



AA	Phillips Screw* Vis Phillips* Tornillo Phillips*			
Quantity Quantité Cantidad	20	Replace Remplacer Reemplazar		

Name - Nom - Nombre	Reason of replacement/Raison de remplacement/Razón del reemplazo <input type="checkbox"/> Missing/Manquant/Ausente <input type="checkbox"/> Damaged/Endommagé/Dañado <input type="checkbox"/> Not Fit/Ne rentre pas/No ajusta <input type="checkbox"/> Other, explain/Autre, expliquer/Otro, explicar <hr style="border: 0; border-top: 1px solid black; margin-bottom: 5px;"/> <hr style="border: 0; border-top: 1px solid black; margin-bottom: 5px;"/>
Address - Adresse - Dirección	
City/State/Zip - Ville/Province/Code postal - Ciudad/Estado/Zona Postal	
Phone - Téléphone - Teléfono	

IMPORTANT! Control No. is required to ensure parts will fit.

IMPORTANT! Le numéro de contrôle est nécessaire pour s'assurer que les pièces s'adaptent.









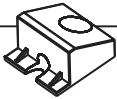
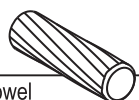
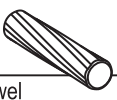

¡IMPORTANTE! El número de control es necesario para garantizar que las piezas se ajusten.

Parts List - Liste des pièces - Lista de partes

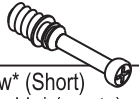
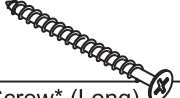
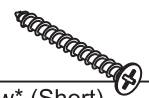
* Screw Driver is required and not included in the package.

* Un tournevis est nécessaire mais n'est pas inclus avec cet ensemble.

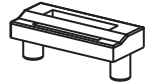
* Se requiere desarmador de cruz y no viene incluido.

 BB Gusset Gousset Esquinero	10 <i>Replace</i> <i>Remplacer</i> <i>Reemplazar</i>	 CC Large Wood Dowel Grande goujon en bois Clavija grande de madera	16 <i>Replace</i> <i>Remplacer</i> <i>Reemplazar</i>	 DD Small Wood Dowel Petite goujon en bois Clavija pequeño de madera	10 <i>Replace</i> <i>Remplacer</i> <i>Reemplazar</i>	 EE Large Cam Lock* Grande serrure batteuse* Grande cam-lock*	10 <i>Replace</i> <i>Remplacer</i> <i>Reemplazar</i>	 FF Cam Lock Screw* (Long) Vis à blocage rapide* (long) Tornillo para cam-lock* (largo)	10 <i>Replace</i> <i>Remplacer</i> <i>Reemplazar</i>	
 GG Small Cam Lock* Petite serrure batteuse* Pequeño cam-lock*	10 <i>Replace</i> <i>Remplacer</i> <i>Reemplazar</i>	 HH Cam Lock Screw* (Short) Vis à blocage rapide* (courte) Tornillo para cam-lock* (corto)	10 <i>Replace</i> <i>Remplacer</i> <i>Reemplazar</i>	 II Phillips Screw* (Long) Vis Phillips* (long) Tornillo Phillips* (largo)	6 <i>Replace</i> <i>Remplacer</i> <i>Reemplazar</i>	 JJ Phillips Screw* (Short) Vis Phillips* (courte) Tornillo Phillips* (corto)	20 <i>Replace</i> <i>Remplacer</i> <i>Reemplazar</i>	 KK Small Screw A* Petit vis A* Tornillo pequeño A*	10 <i>Replace</i> <i>Remplacer</i> <i>Reemplazar</i>	
For Drawer Rail, Wheel and Door Hinge Pour glissière de tiroir, roulette et charnière de porte Para brasadera, rueda con bisagra del puerta	 LL Small Screw B* Petit vis B* Tornillo pequeño B*	48 <i>Replace</i> <i>Remplacer</i> <i>Reemplazar</i>	 MM Wheel Roulette Rueda	3 <i>Replace</i> <i>Remplacer</i> <i>Reemplazar</i>	 NN Locking Wheel Roue à verrouillage Rueda con cerrójo	2 <i>Replace</i> <i>Remplacer</i> <i>Reemplazar</i>	 OO Door Stopper Goujon de porte Clavija para del puerta	1 <i>Replace</i> <i>Remplacer</i> <i>Reemplazar</i>	 PP Door Hinge Charnière de porte Bisagra del puerta	2 <i>Replace</i> <i>Remplacer</i> <i>Reemplazar</i>

Check list - Liste de vérification - Lista de Verificación

Cabinet - Meuble - Armario

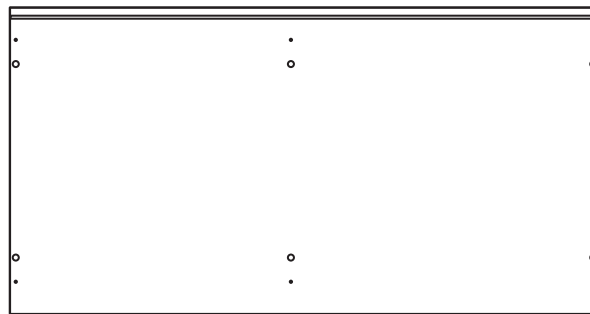
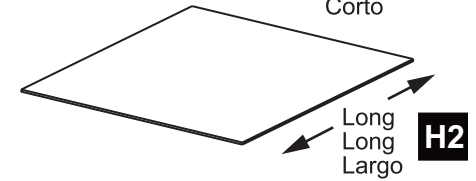
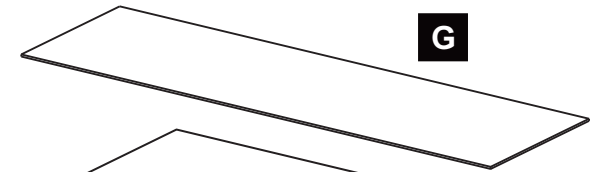
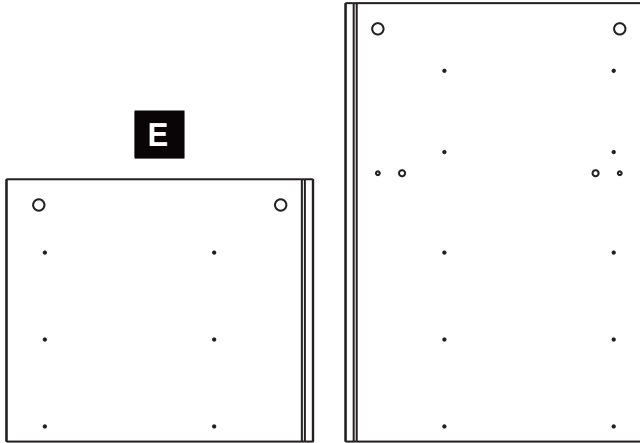
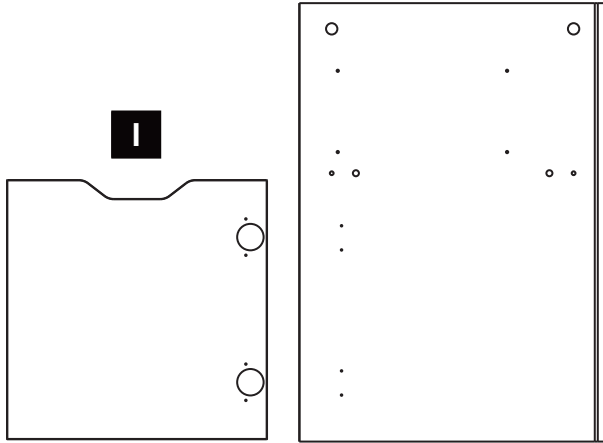
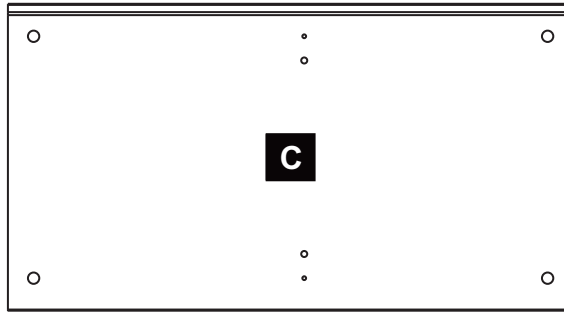
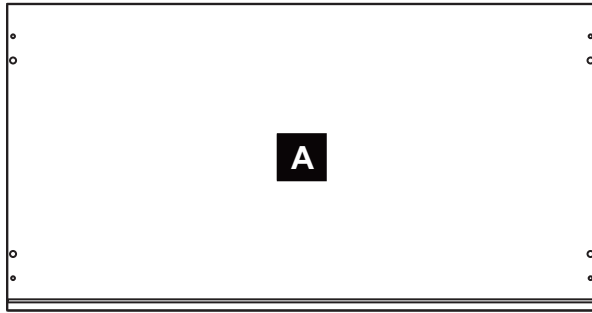

Check list - Liste de vérification - Lista de Verificación

Drawer - Tiroir - Cajón **x2**

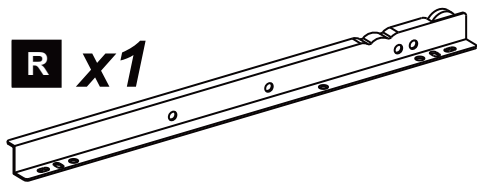
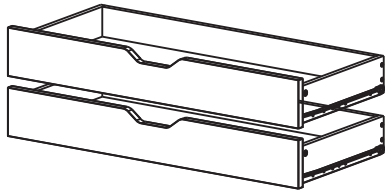

R x1



LL x2

P



L



K

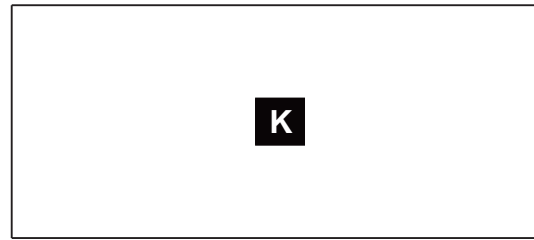

Q



J



DD

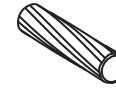

GG



HH

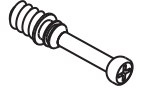

x2

JJ



x4

S

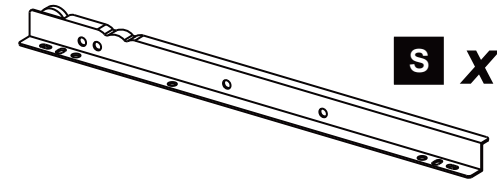

x1

LL



x2

Drawer - Tiroir - Cajón **x3**

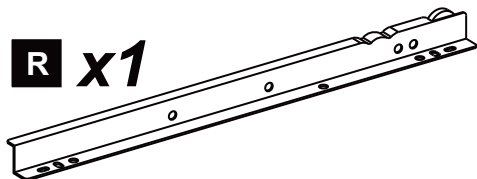
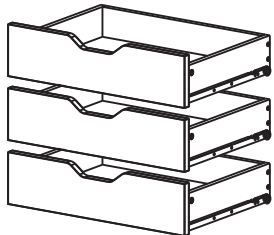

R x1



LL x2

P



O



N

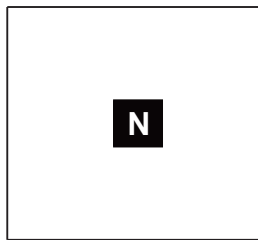

Q



M



DD

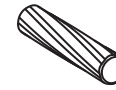

GG



HH

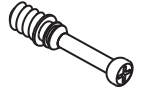

x2

JJ



x4

S

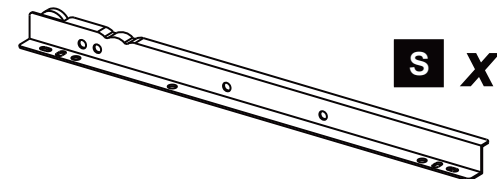

x1

LL



x2

Rail Installation Guide - Guide d'installation des rails - Guía para instalación de rieles

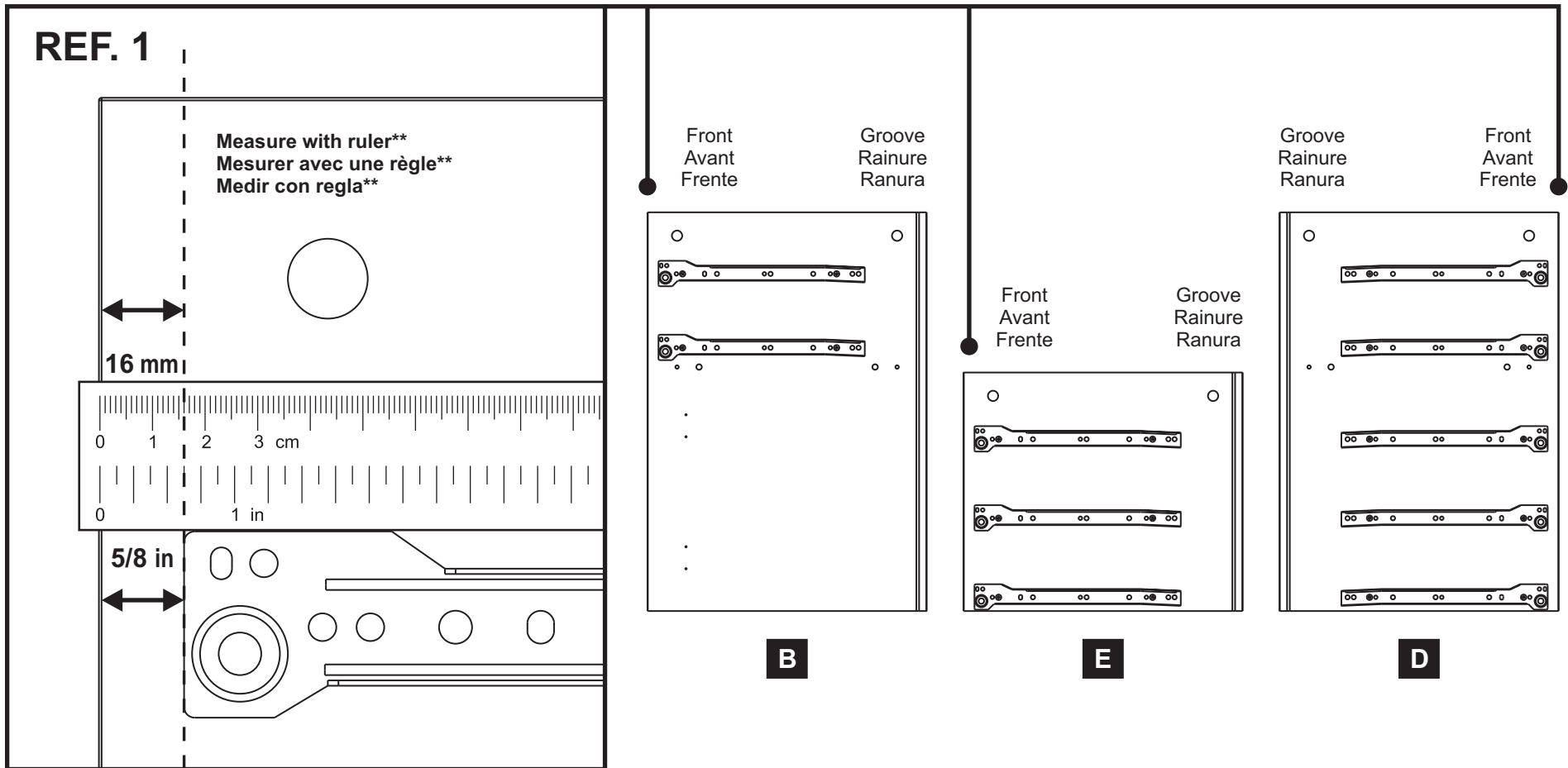

Using a ruler to measure, align the drawer rail guide **5/8 in (16 mm)** from the front edge of side panel. Locate the 2 holes on the drawer rail guide that align with holes on the side panel and apply screws to secure.

À l'aide d'une règle, alignez le coulisse de tiroir à **16 mm (5/8 po)** du bord avant du panneau. Localisez les 2 trous dans le coulisse qui s'alignent avec les trous dans le panneau et appliquez des vis pour fixer.

Usando una regla, alinee la pista de cajón a **16 mm (5/8 pulg)** del borde frontal del panel. Ubique los 2 orificios en la pista que se alinean con los orificios del panel y aplique tornillos para asegurar.

****IMPORTANT:**

Drawers will not align correctly unless drawer rail guide is positioned **EXACTLY 5/8 in (16 mm)** from edge of side panel.

****IMPORTANT:**

Les tiroirs ne s'aligneront pas correctement à moins que les coulisses des tiroirs ne soient positionnées **EXACTEMENT à 16 mm (5/8 po)** du bord du panneau.

****IMPORTANTE:**

Los cajones no alinearán correctamente a menos de que la pista de cajón este colocada **EXACTAMENTE a 16 mm (5/8 pulg)** del borde del panel.

Assembly Instructions - Instructions d'assemblage - Instrucciones de ensamblaje

1

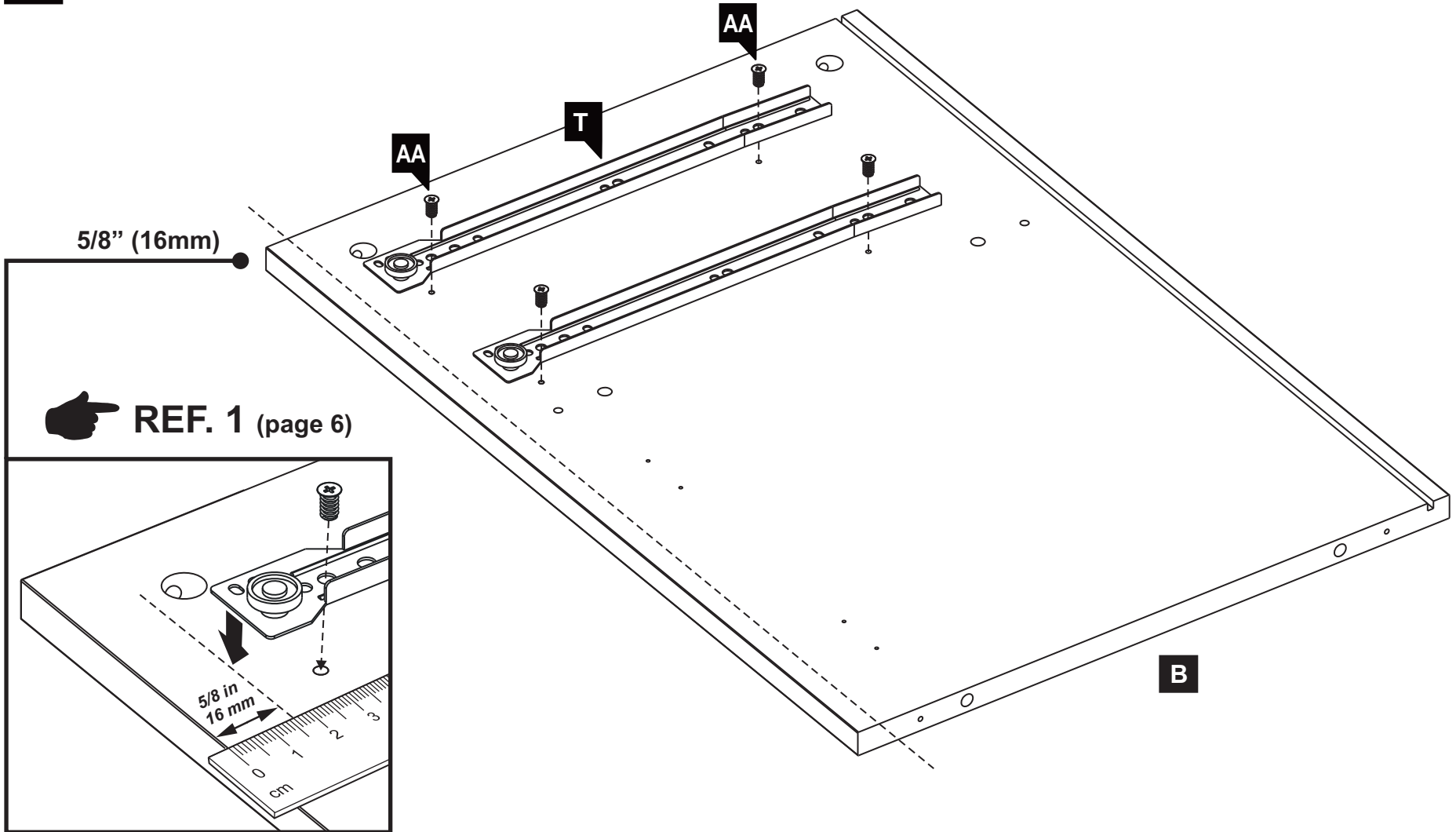

T x2



AA x4



Tip: Recommend to have helping hands.
Conseil: Demandez de l'aide.
Consejo: Se recomienda que le ayuden.

2

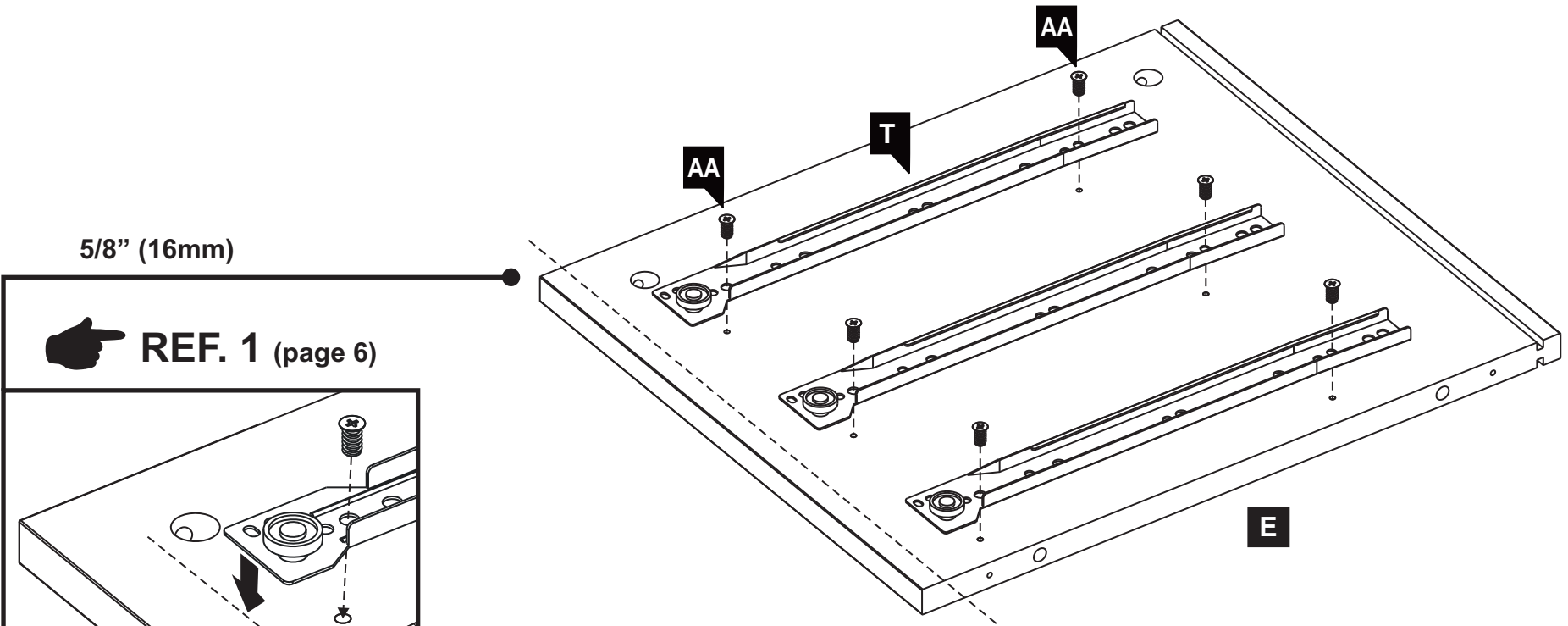

 **REF. 1** (page 6)

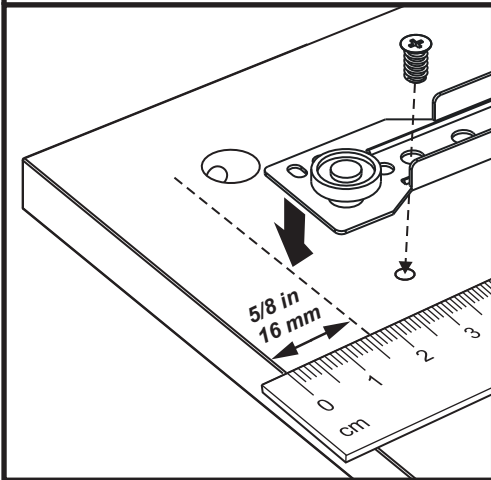

T x3



 **AA x6**



*Tip: Recommend to have helping hands.
Conseil: Demandez de l'aide.
Consejo: Se recomienda que le ayuden.*

Assembly Instructions - Instructions d'assemblage - Instrucciones de ensamblaje

3

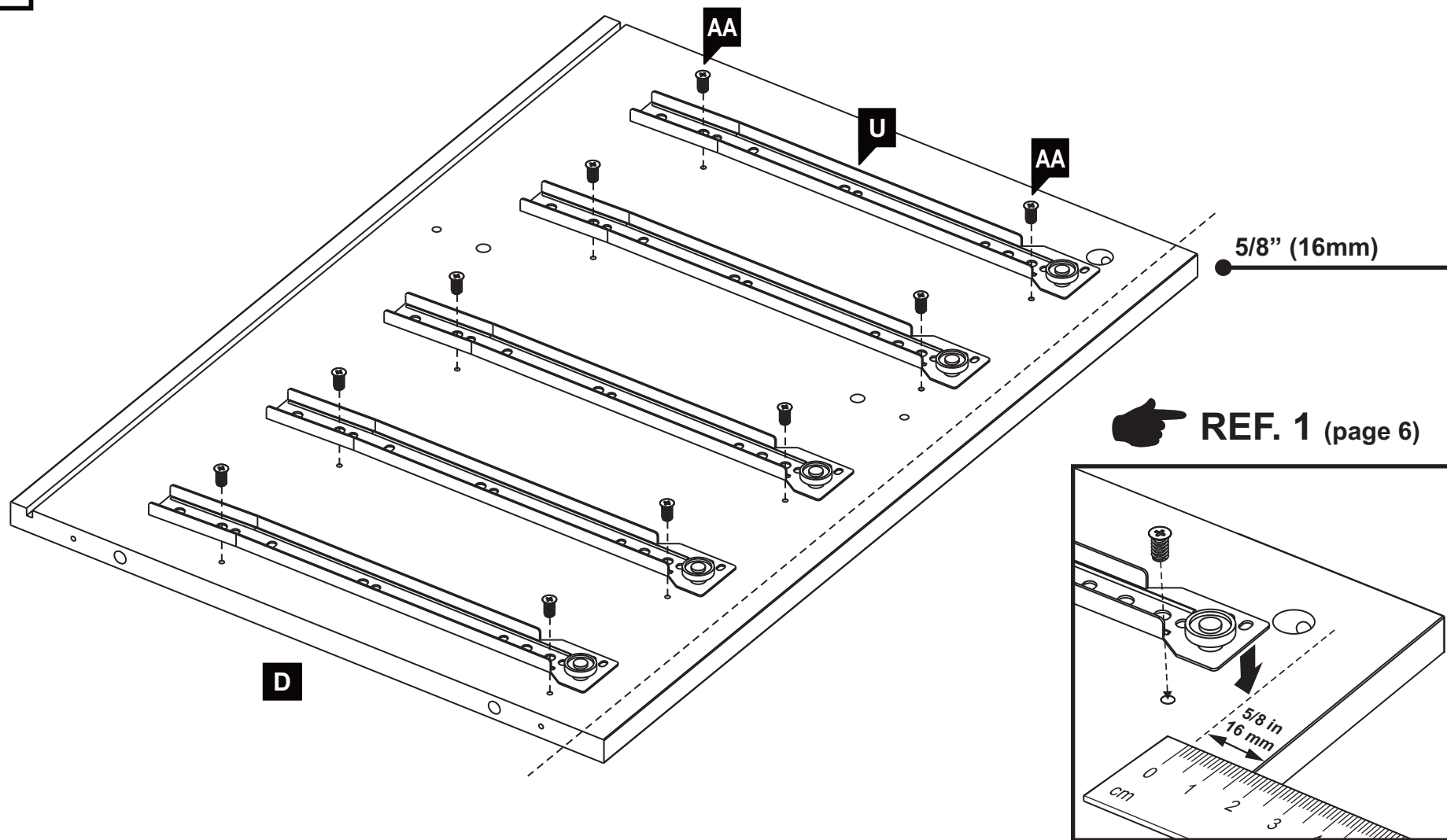

*Tip: Recommend to have helping hands.
Conseil: Demandez de l'aide.
Consejo: Se recomienda que le ayuden.*

U x5



AA x10

Assembly Instructions - Instructions d'assemblage - Instrucciones de ensamblaje

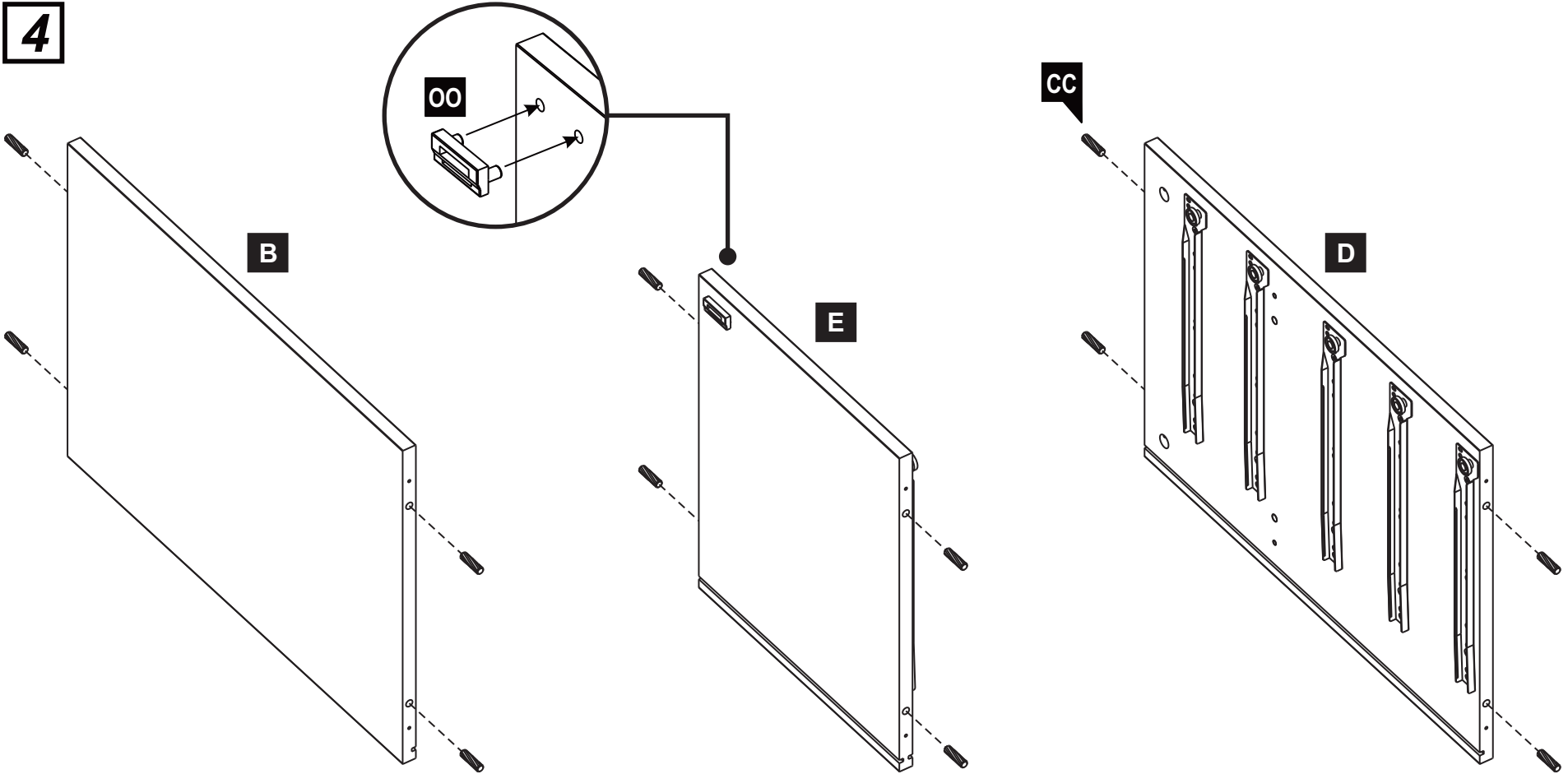

REF. 2  **CC** x12

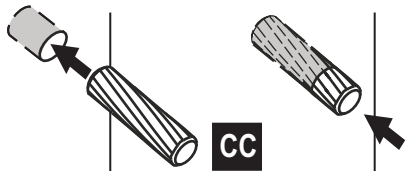

Important!

Push or gently tap wood dowel as far into the hole as possible.

Important!

Poussez ou tapez doucement le goujon en bois aussi loin que possible dans le trou.

Importante!

Empuje o suavemente golpie el clavije en el olo lo mas que pueda.

Assembly Instructions - Instructions d'assemblage - Instrucciones de ensamblaje

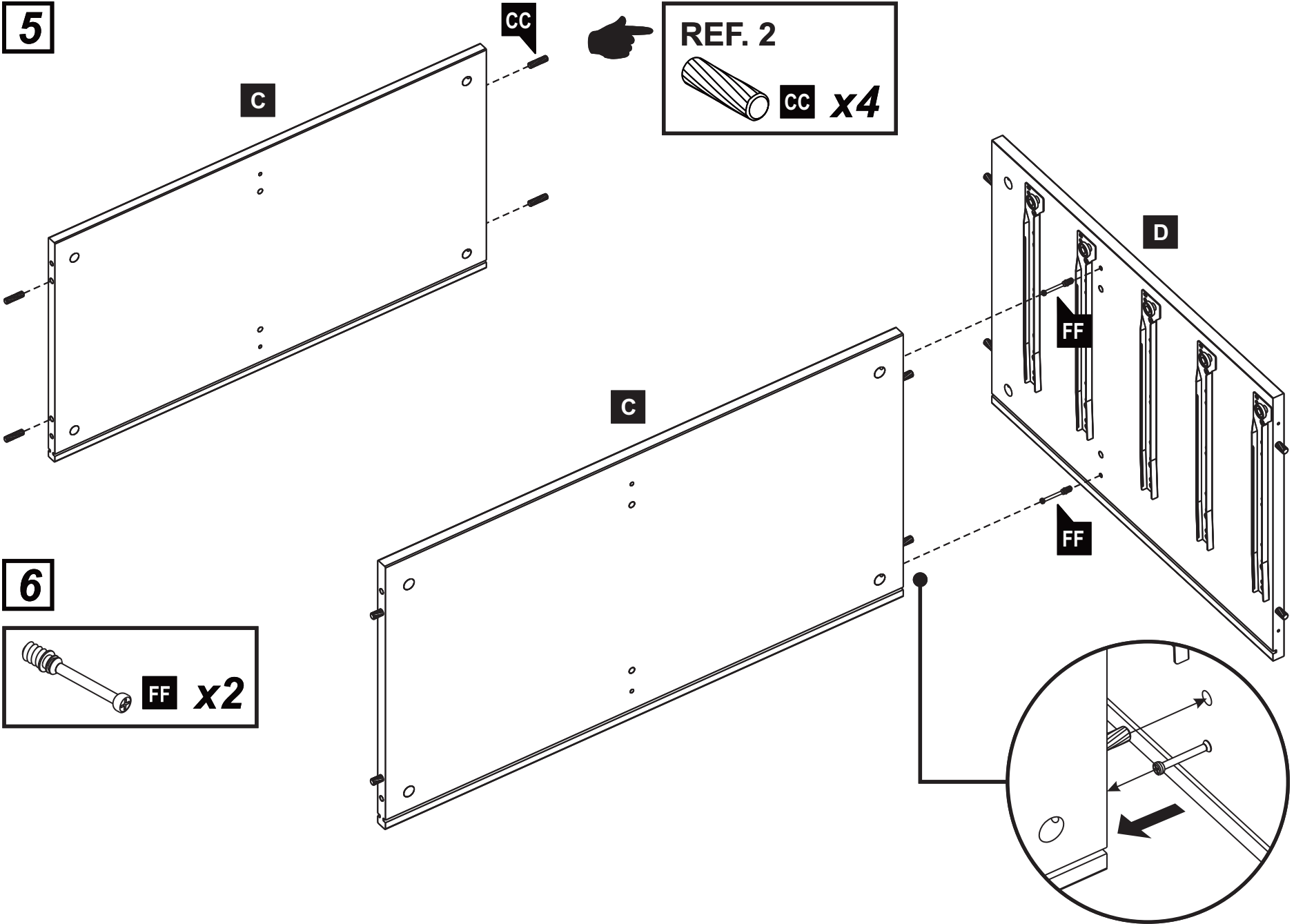

Assembly Instructions - Instructions d'assemblage - Instrucciones de ensamblaje

7

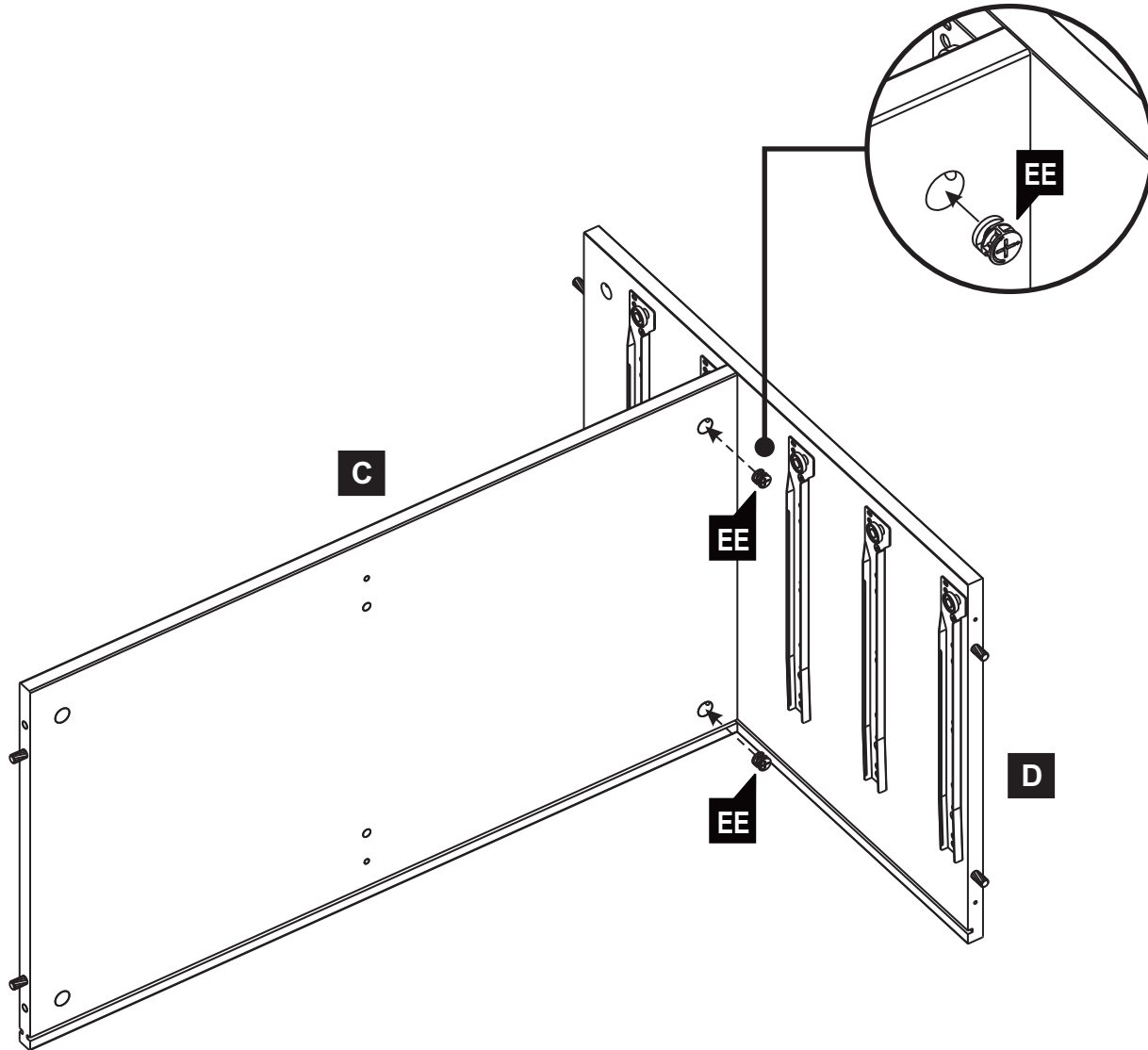

REF. 3  **EE** x2

Note: Insert cam-lock in open position, rotate to open position with screw driver if necessary.

Open
Ouvrir
Abierto

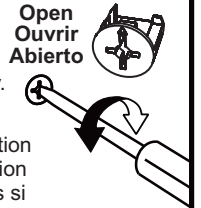

Remarque: Insérez la serrure batteuse en position ouverte, tourner en position ouverte avec le tournevis si nécessaire.

Nota: Inserta el "cam-lock" en posición abierta, volteé en posición abierta con desarmador si es necesario.

Turn to lock with screw-driver.
Warning: Do not over tighten cam lock.

Locked
Verrouiller
Cerrado

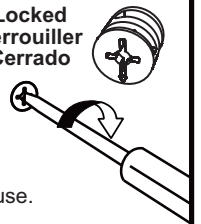

Tourner pour verrouiller avec tournevis.
Avertissement: Ne pas trop serrer serrure batteuse.

Volteé para cerrar con desarmador.
Advertencia: No sobre-aprietecam-lock.

Assembly Instructions - Instructions d'assemblage - Instrucciones de ensamblaje

8

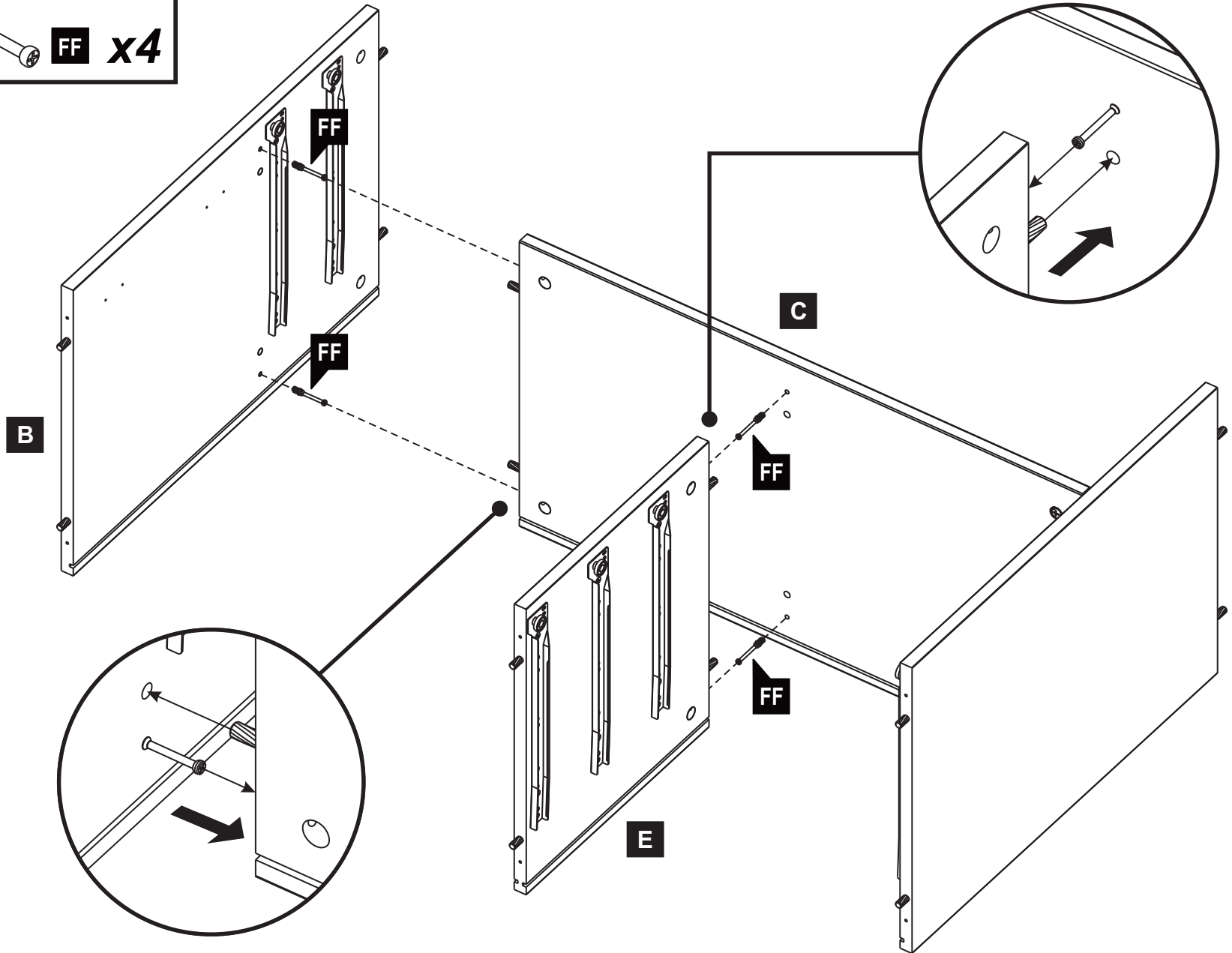
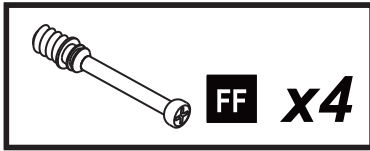

Switched View
Vue retournée
Vista cambiada

Assembly Instructions - Instructions d'assemblage - Instrucciones de ensamblaje

9



REF. 3
 **EE** x4

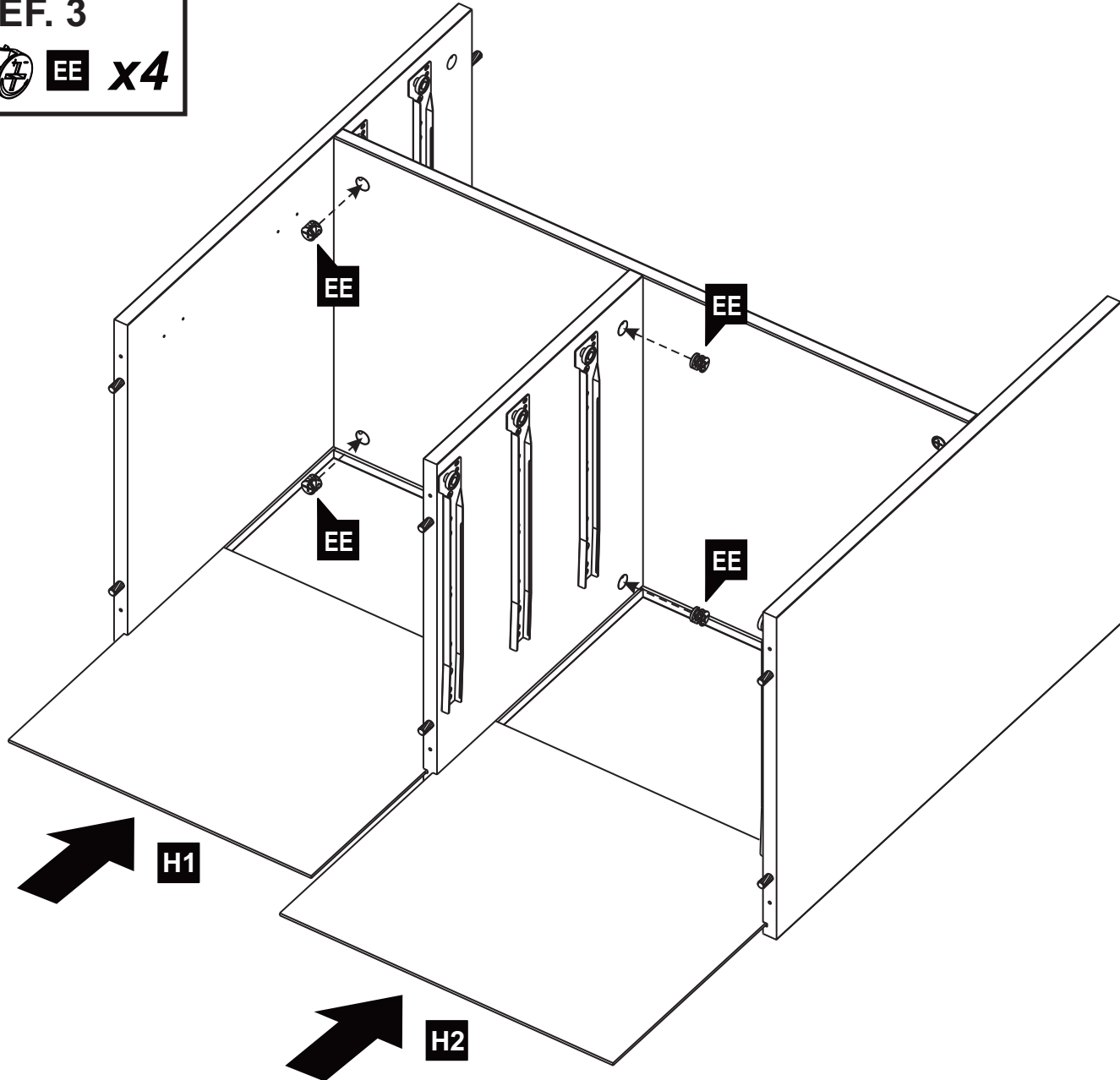

Assembly Instructions - Instructions d'assemblage - Instrucciones de ensamblaje

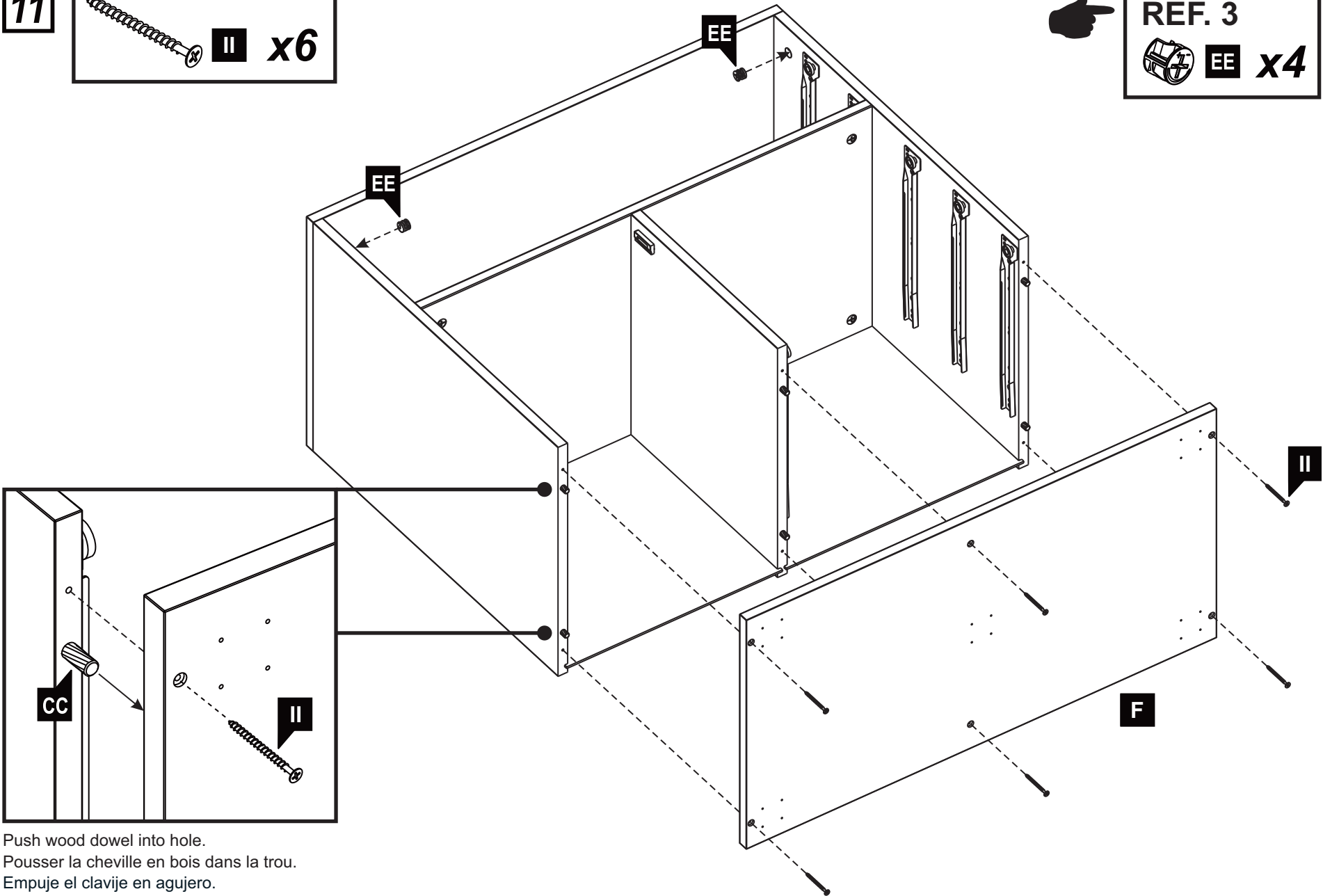

Push wood dowel into hole.
Pousser la cheville en bois dans la trou.
Empuje el clavije en agujero.

Assembly Instructions - Instructions d'assemblage - Instrucciones de ensamblaje

13

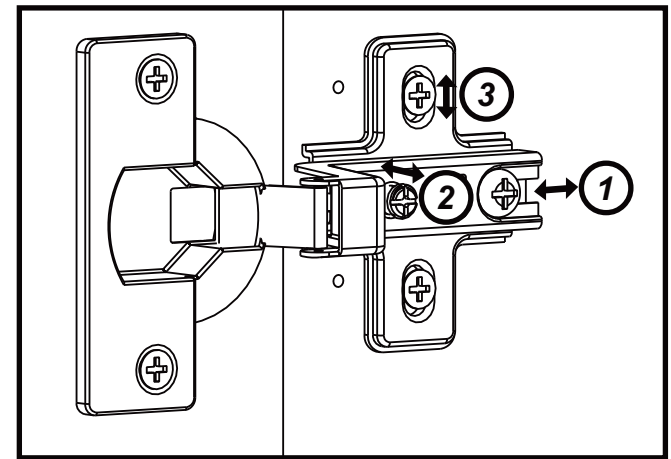
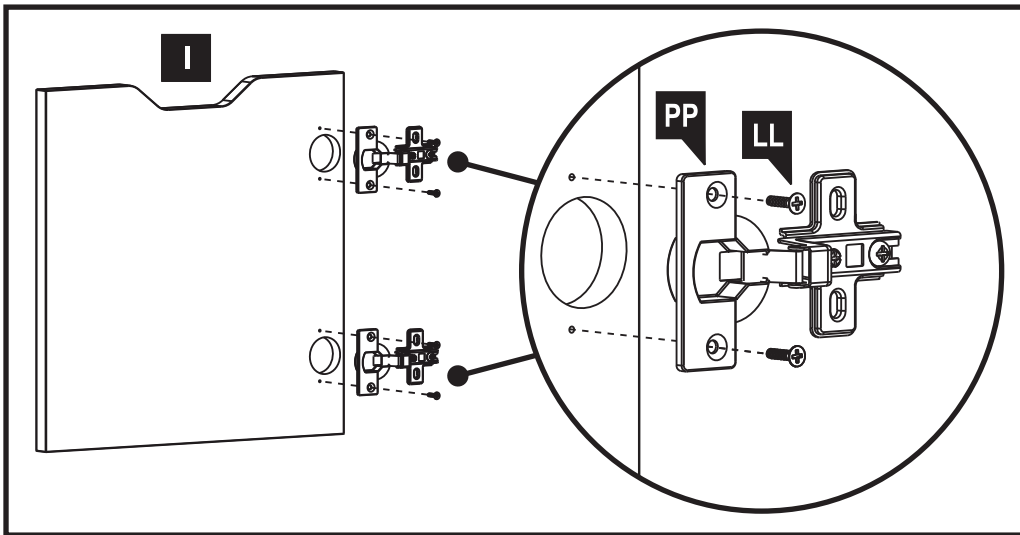

- 1 To adjust door forward and back
Pour ajuster la porte vers l'avant et vers l'arrière
Para ajustar puerta al frente y para atrás
- 2 To adjust door horizontally (side to side)
Pour ajuster la porte horizontalement (d'un côté à l'autre)
Para ajustar puerta horizontalmente (de lado a lado)
- 3 To adjust door vertically (up and down)
Pour ajuster la porte verticalement (de haut en bas)
Para ajustar puerta verticalmente (arriba y abajo)

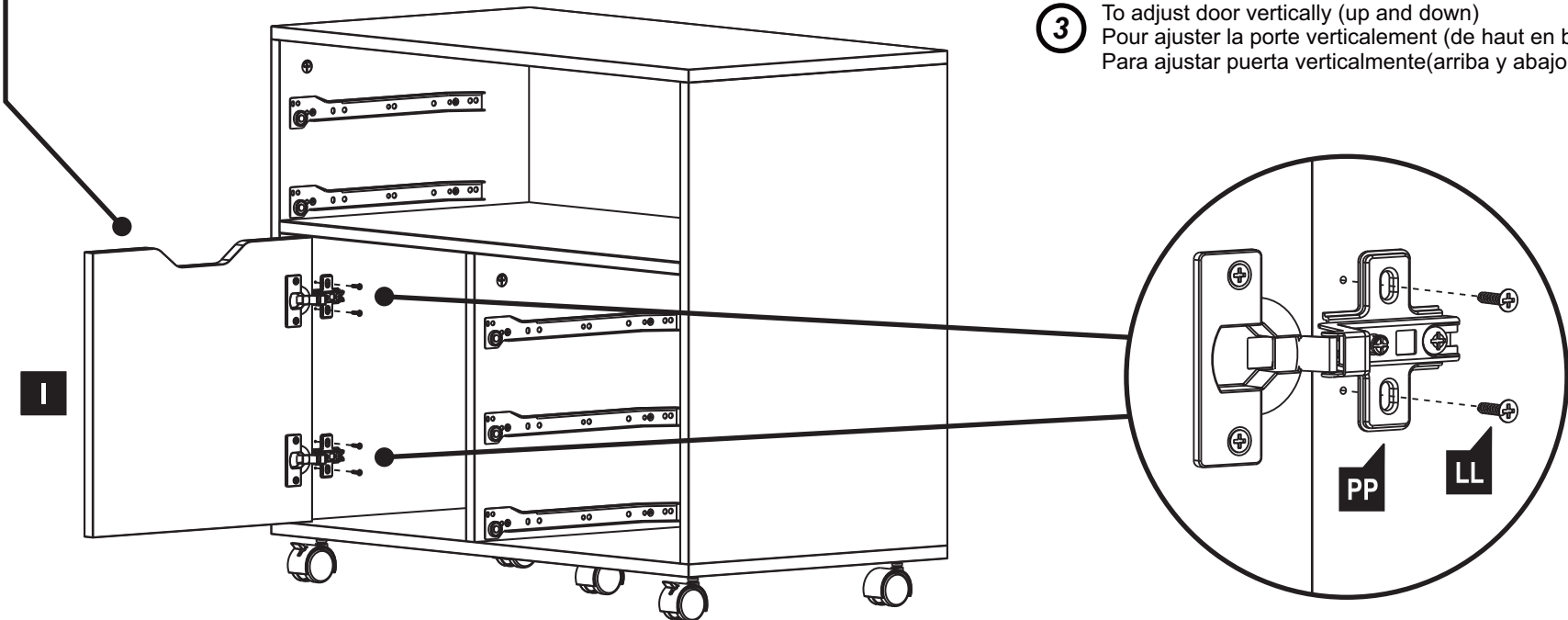

12 Small Drawer - Petit tiroir - Cajón pequeño **x3**

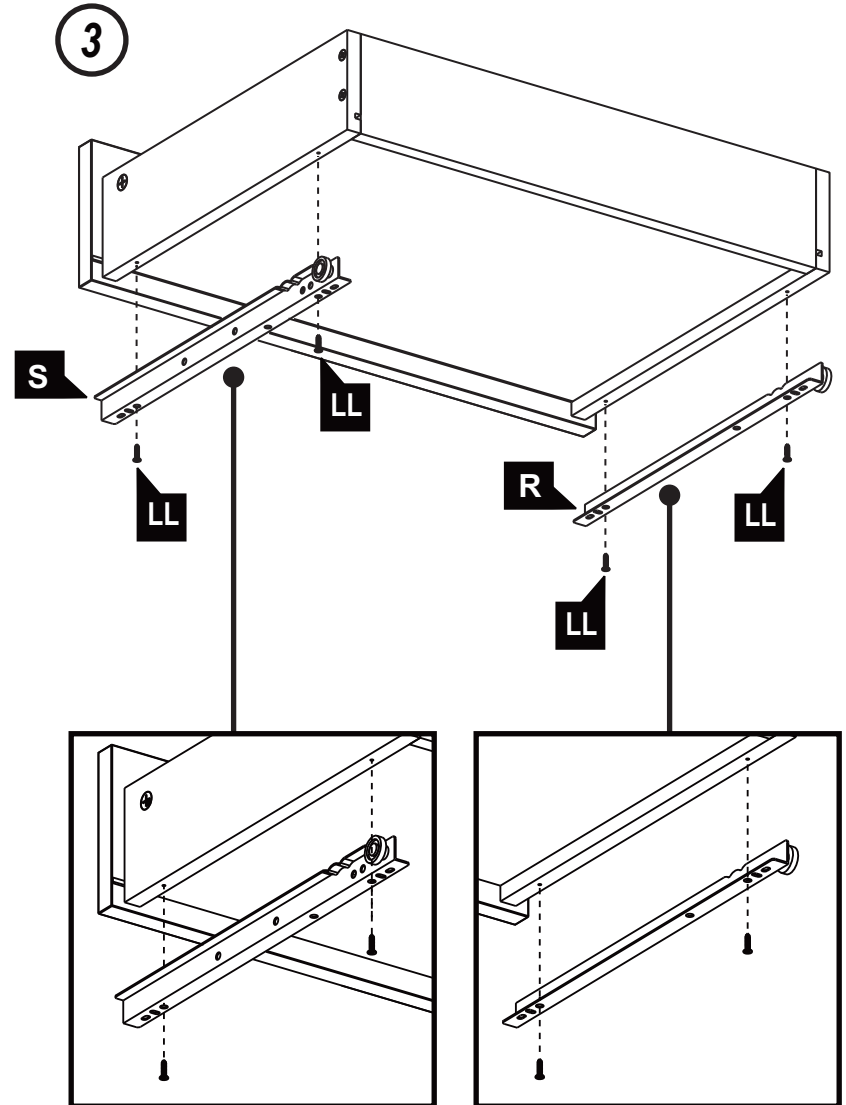
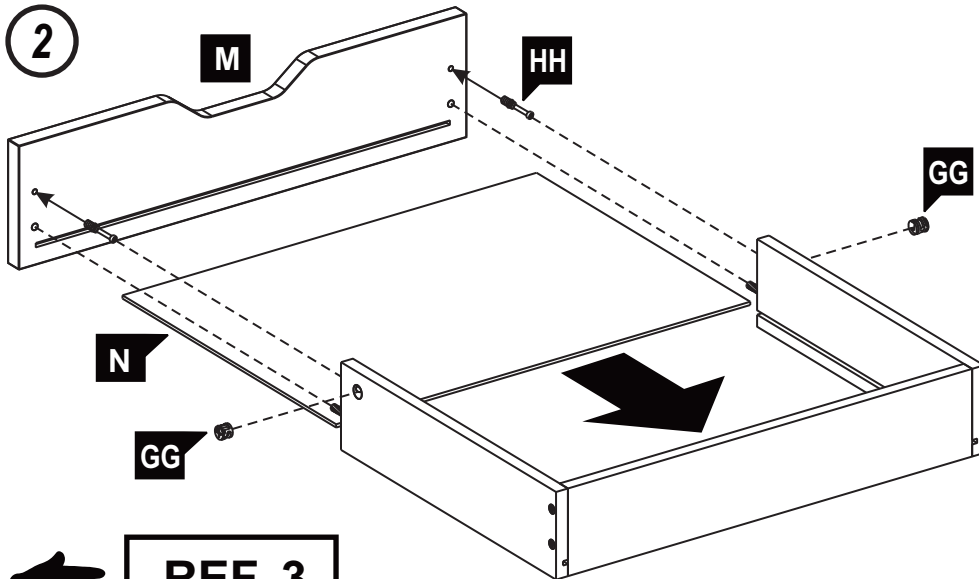
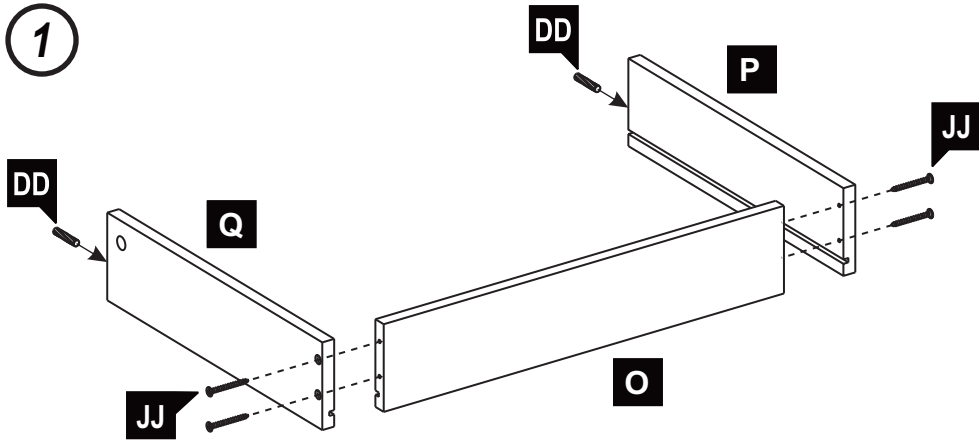

15 Large Drawer - Grand tiroir - Cajón grande **x2**

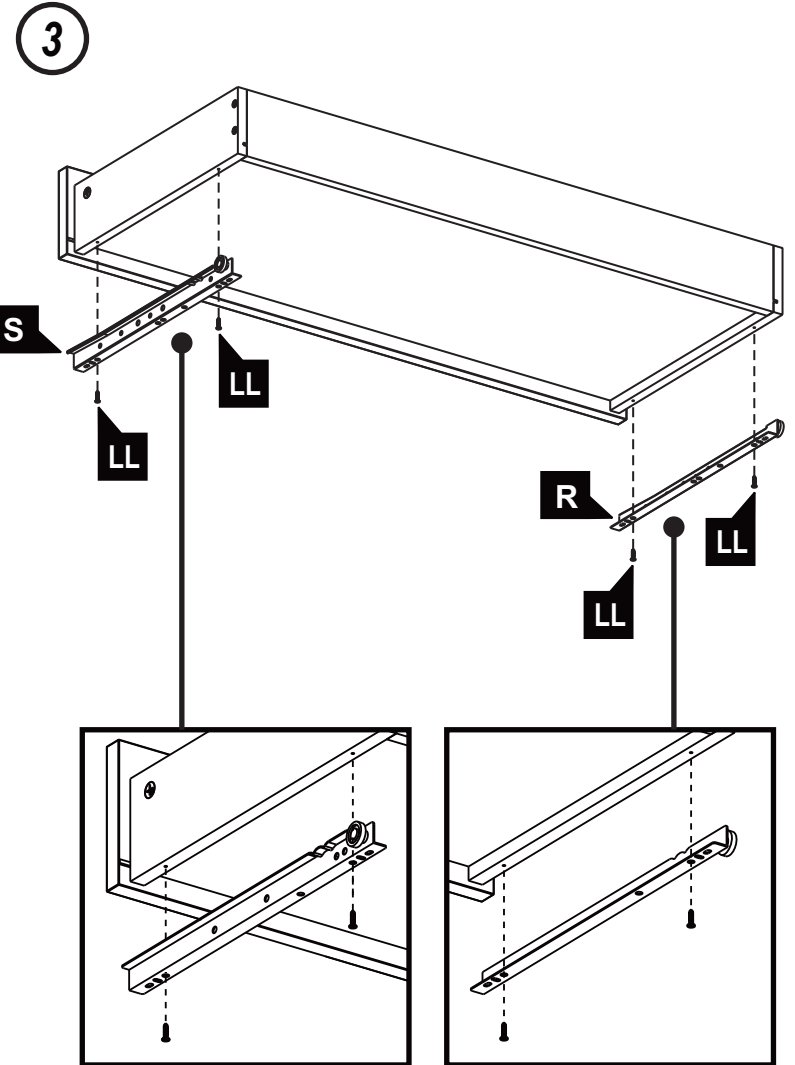
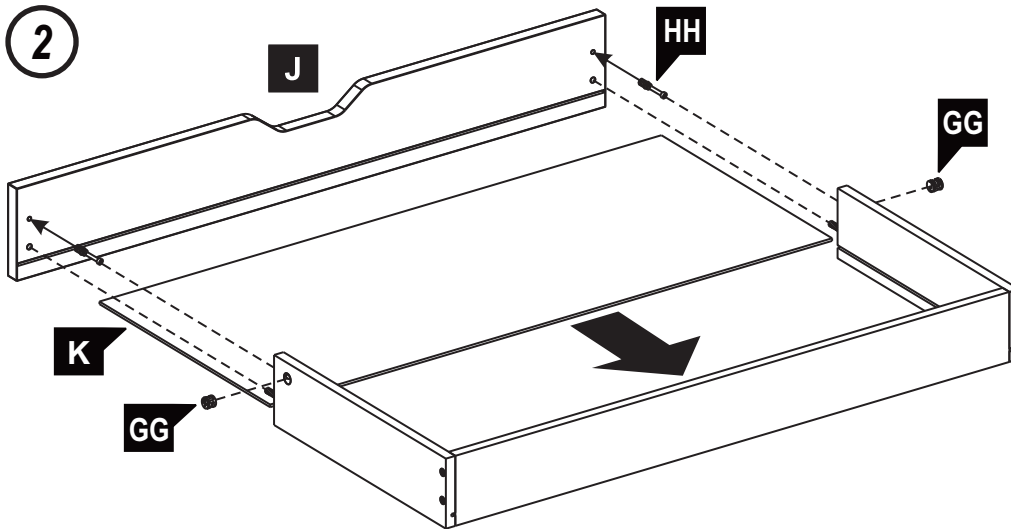
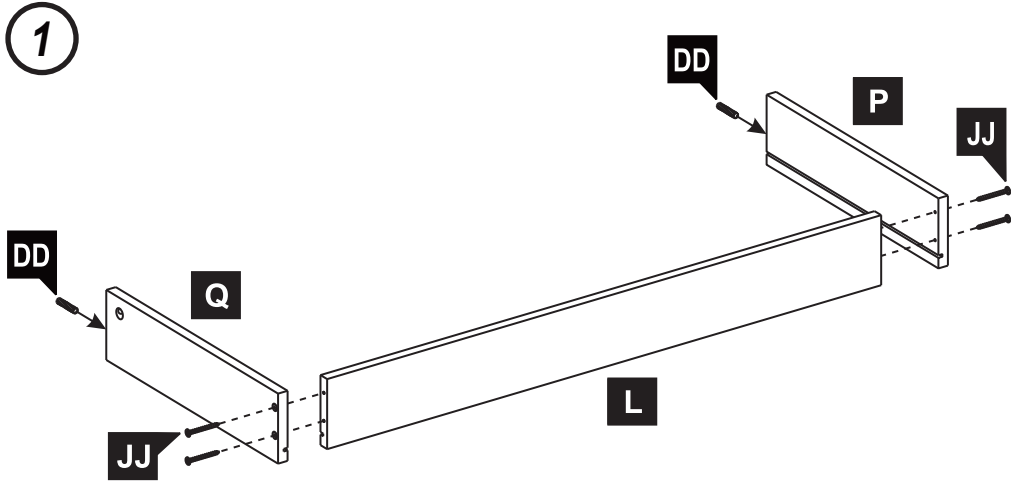

Assembly Instructions - Instructions d'assemblage - Instrucciones de ensamblaje

16

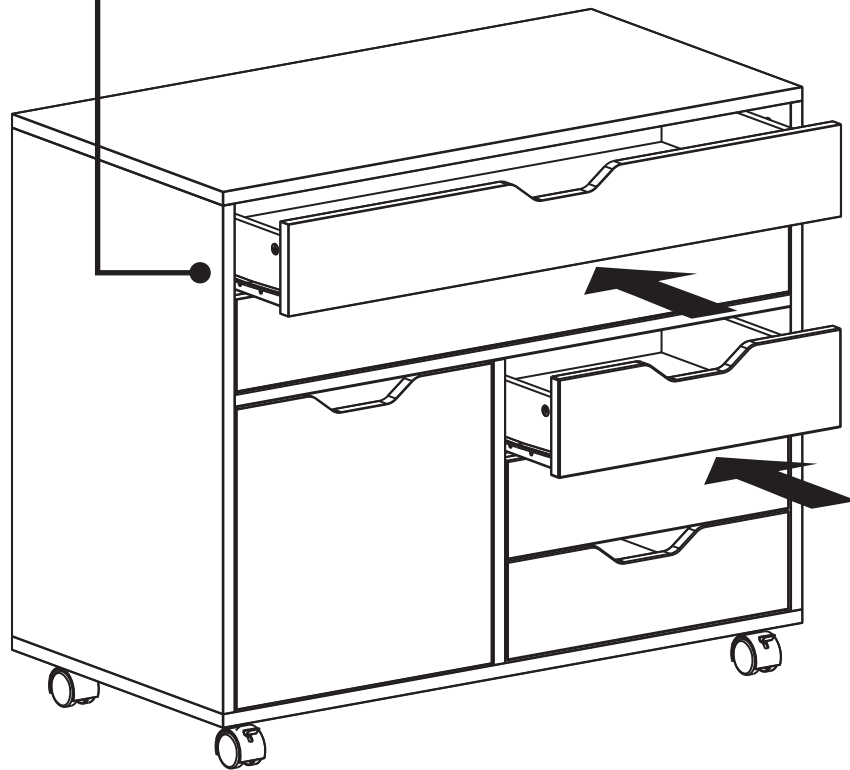
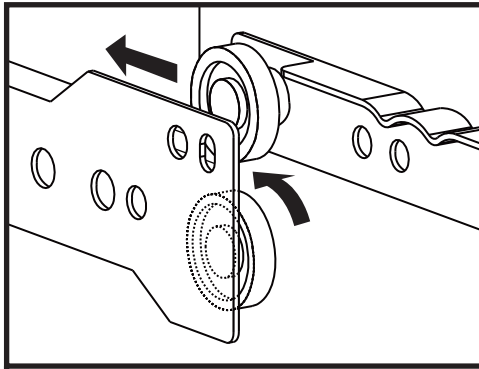

17



Back Panel
Panneau arrière
Panel de atrás

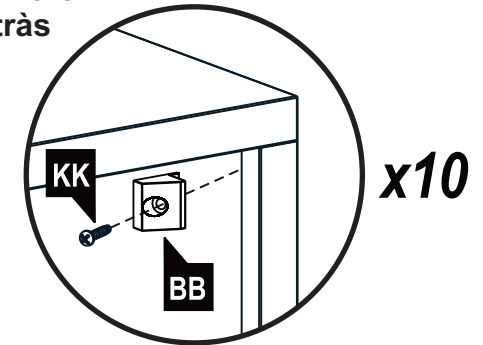

x10

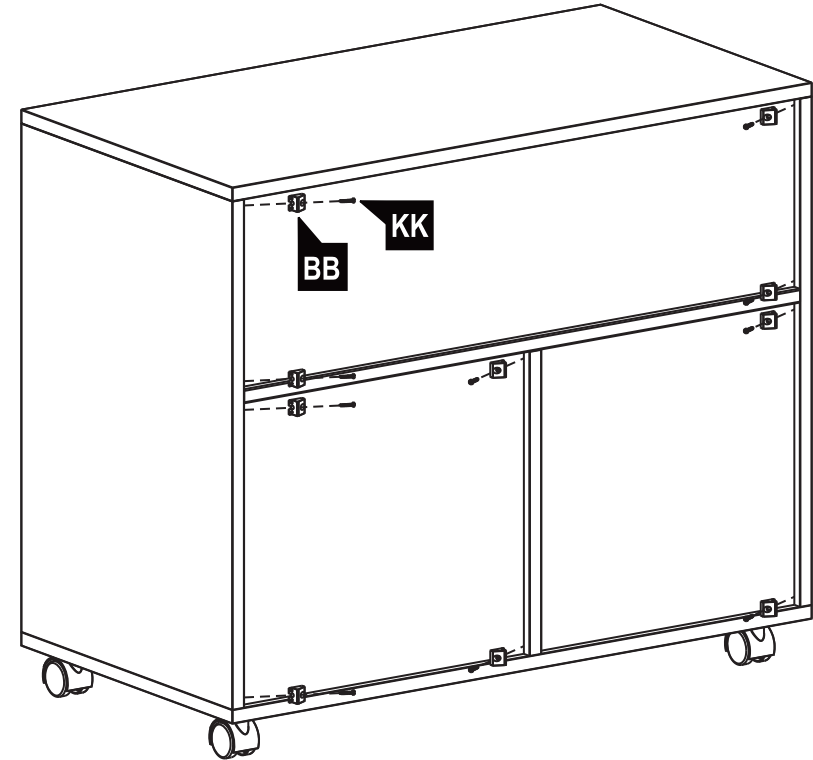

Care instructions: To clean, wipe with damp cloth and dry thoroughly. Use mild soap if necessary. Avoid use of commercial waxes or polishes or abrasive cleaning materials.

Instructions d'entretien: Pour nettoyer, essuyez avec un linge humide et séchez à fond. Utilisez un savon doux au besoin. Évitez d'utiliser des cires ou produits à polir de type commercial ou des matériaux de nettoyage abrasifs.

Instrucciones para el cuidado: Para limpiar, frótelo con algo húmedo y séquelo bien. Use un jabón suave si es necesario. Evite el uso de ceras o pulidores comerciales o materiales abrasivos.