

ASSEMBLY INSTRUCTION

Before you begin, Please follow Assembly Instruction carefully. Then follow them step by step.

PART LIST		
A	TABLE TOP	1 PC
B	TABLE LEGS	4PCS
HARDWARE LIST		
C	JCBB BOLT (LONG)	8 PCS
D	FLAT WASHER	8 PCS
E	ALLEN KEY	1 PC
F	SPRING WASHER	8 PCS

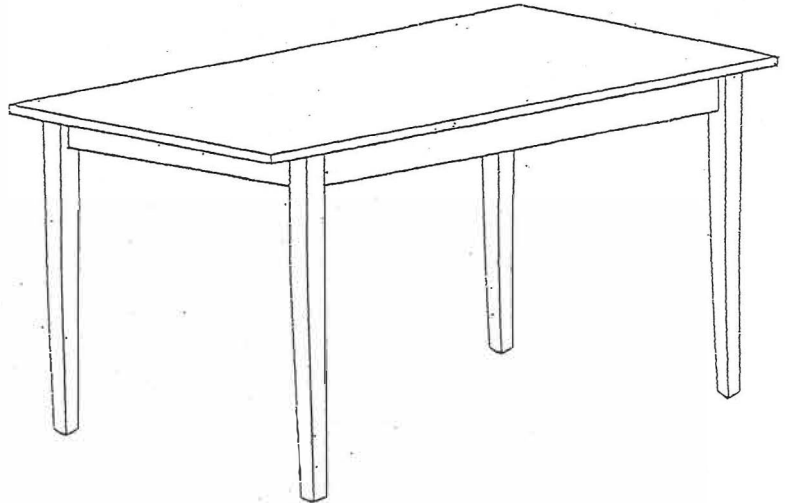

IMPORTANT NOTE : PLACE ALL WOODEN PARTS ON A CLEAN AND SMOOTH SURFACE SUCH AS A RUG OR CARPET TO AVOID THE PARTS FROM BEING SCRATCHED.



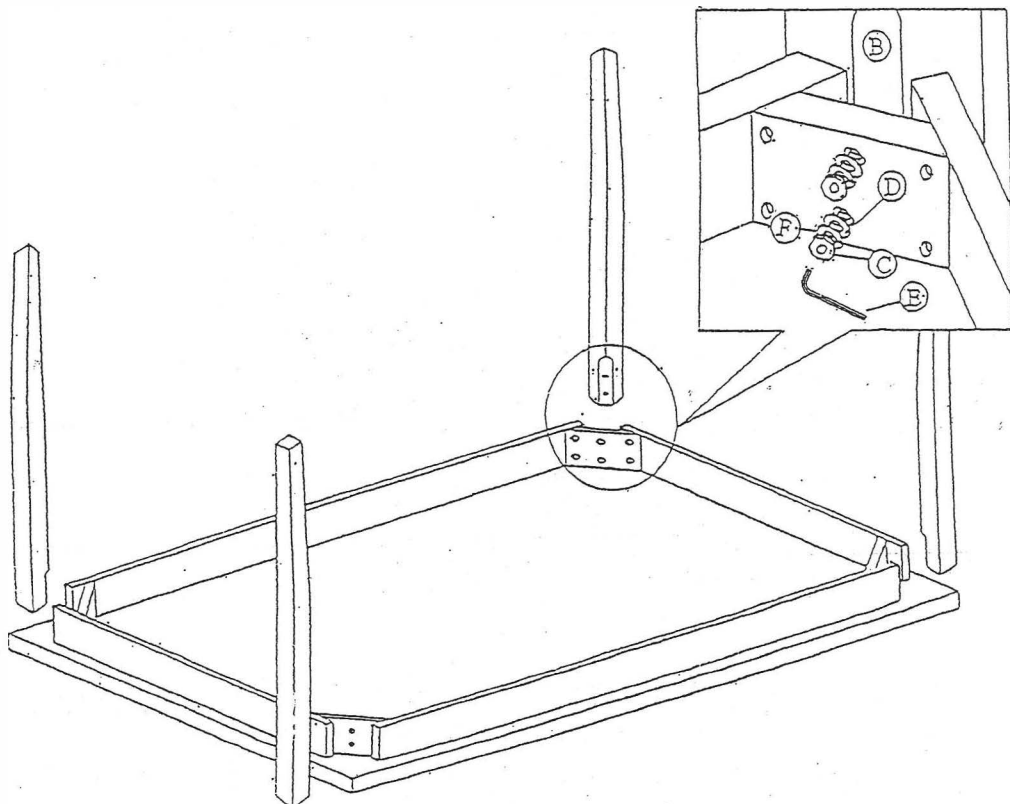

FIX THE TABLE LEGS(B) TO THE CORNER BLOCK WITH "JCBB BOLT" (C) SPRING WASHER (F) AND FLAT WASHER (D). THEN TIGHTEN THE JCBB BOLT (C) BY USING THE ALLEN KEY (E).





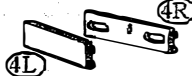

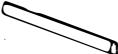

ASSEMBLY INSTRUCTIONS

Read instruction carefully . Be sure you have all parts before you start assembling (see PART LIST & HARDWARE LIST) . To avoid scratching , lay the parts on a clean soft area such as carpet or rugs . Do not tighten all screws unless is instructed .

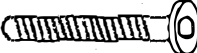
PARTS LIST

NO	DESCRIPTION	QTY	NO	DESCRIPTION	QTY
1	CHAIR BACK 	1 PC	4	SIDE APRON 	2 PCS
2	CHAIR FRONT LEG 	1 PC	5	STRECTHER 	2 PCS
3	CHAIR SEAT 	1 PC			

HARDWARE LIST

NO	DESCRIPTION	QTY	NO	DESCRIPTION	QTY
A	ICBC SCREW 50MM 	4 PCS	D	SCREW 38MM 	4 PCS
B	SPRING WASHER 	4 PCS	E	SCRE W' 32MM 	3 PCS
C	FLAT WASHER 	4 PCS	F	ALLEN KEY 	1 PC

FULLY SET UP

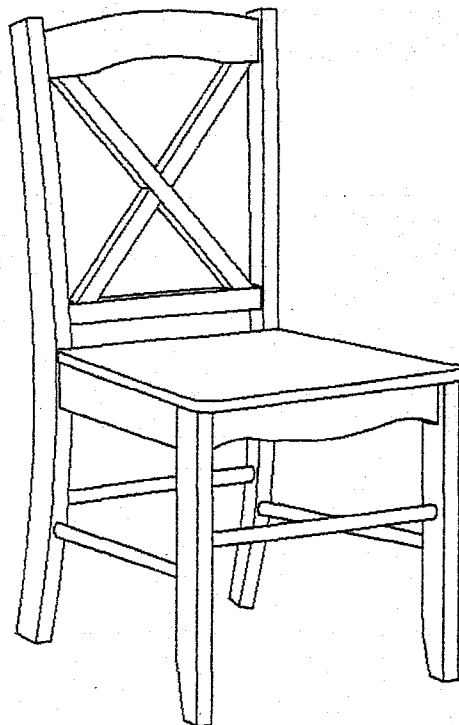

ASSEMBLY INSTRUCTIONS

STEP 1

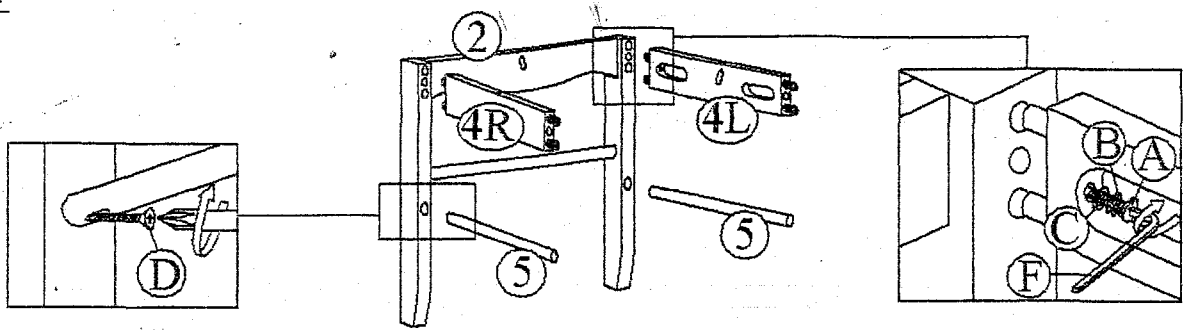

Use allen key (F) , JCBC screw 50MM (A) , spring washer (B) and flat washer (C) to assemble left and right side apron (#4L & 4R) to chair front leg (#2) .

Use philips screw driver and screw 38MM (D) to assemble both stretchers (#5) to chair front leg (#2) .
Do not tighten screws .

STEP 2

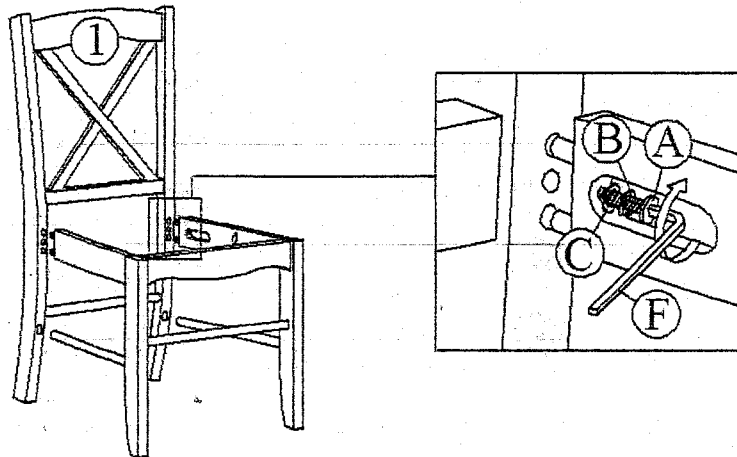

Use allen key (F) , JCBC screw 50MM (A) , spring washer (B) and flat washer (C) to assemble left and right side apron to chair back (#1) . Tighten all screws .

STEP 3

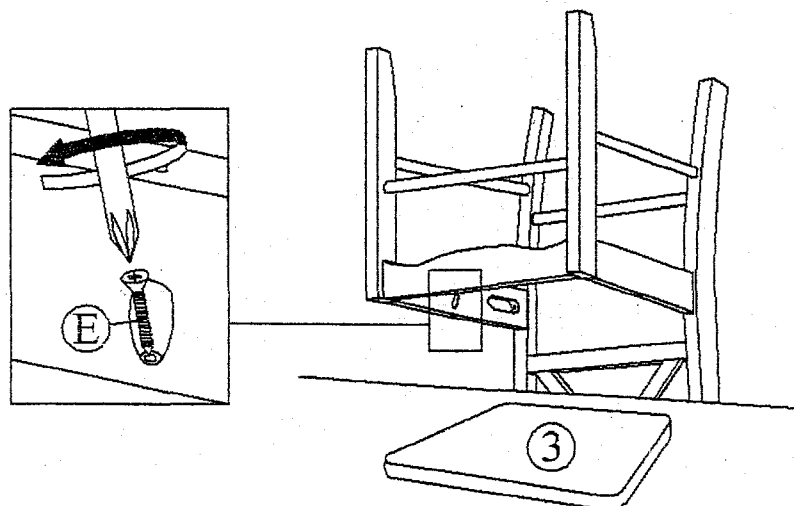

Use philips screw driver , screw 32MM (E) to assemble chair seat (#3) to seat . Tighten the screw .





After few days of initial assembly , the product may have acclimated to new environment , please retighten all hardware again .

ASSEMBLY INSTRUCTION

IMPORTANT NOTE :

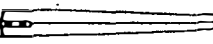
BEFORE YOU BEGIN, PLEASE READ AND FOLLOW THE ASSEMBLY INSTRUCTIONS CAREFULLY.

- IDENTIFY AND SEPARATE ALL PARTS BEFORE DISCARDING PACKAGING.
- PLACE WOODEN PARTS ON A CLEAN SOFT SURFACE TO AVOID SCRATCHING THE PARTS.
- DO NOT USE POWER TOOL FOR ASSEMBLY.
- AS WITH ALL FURNITURE , OCCASIONALLY CHECK TO INSURE HARDWARE IS TIGHT.

PARTS LIST		
NO	DESCRIPTION	QTY
1	TABLE TOP 	1PC
2	TABLE LEG 	4PCS
HARDWARE LIST		
NO	DESCRIPTION	QTY
A	JCBC BOLT M6 X 60MM 	8PCS
B	FLAT WASHER 	8PCS
C	SPRUNG WASHER 	8PCS
D	M4 ALLEN KEY 	1PC

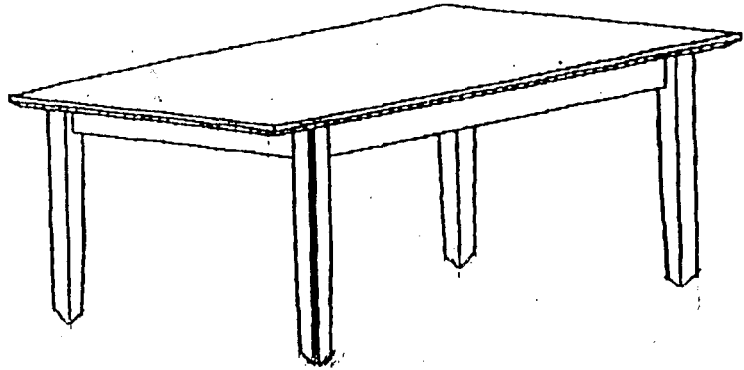

ATTACH THE TABLE LEGS (2) TO THE CORNER BLOCK WITH JCBC BOLT (A) SPRUNG WASHER (C) AND FLAT WASHER (B). TIGHTEN THE JCBC BOLT (A) BY USING ALLEN KEY (D)

