



# COMMERCIAL ALL-IN-ONE FOOD SLICER

## BFS450 USER MANUAL





# BENCHFOODS

**BenchFoods is the largest manufacturer of Commercial & Industrial Food Dehydrators worldwide. BenchFoods also now provides food production equipment.**

We ship direct to your door offering free domestic shipping or affordable international shipping options, a 5-Year Comprehensive Warranty, and provide full end-to-end customer service. All of this, combined with up to 50% off retail, saving you thousands.

Designed with continuous commercial use in mind, our Commercial All-In-One Food Slicer effortlessly integrates into any fast-paced environment - from dynamic restaurants and bustling cafes to vibrant pizza parlors and professional catering services. Experience the convenience and reliability that our slicer brings to your kitchen operations!

**Disclaimer - Due to constant factory improvements, the product pictured might differ slightly from the product in this box.**



# TABLE OF CONTENTS

BFS450 MANUAL INTRODUCTION .....	4
IMPORTANT WARNING .....	5
ASSEMBLY AND CHANGING THE DISCS .....	6
SWITCHING ON THE MACHINE .....	8
INSTRUCTION OF THE FEED INLETS .....	8
DISCS AND ACCESSORY OPTIONS .....	9
CLEANING AND MAINTENANCE .....	10
TECHNICAL SPECIFICATIONS .....	11
SAFETY INSTRUCTIONS .....	12
TROUBLE SHOOTING .....	13
5 YEAR COMPREHENSIVE WARRANTY .....	14



# BFS450 MANUAL INTRODUCTION

Thank you for selecting BenchFoods Commercial All-In-One Food Slicer. Please take the time to read this operation manual carefully and thoroughly for proper usage, and pay close attention to the safety precautions. Keep this manual in a secure location, as it can be a valuable resource for assistance at any time.

Please note that due to the ongoing improvement of our products, we reserve the right to update or modify the information contained within this manual. The illustrations included in this manual were created during the development stage and may vary from the actual product



Strong High Performance Motor



Forever Sharp™ Technology



Large Commercial Capacity



Enhanced Safety Features



Quiet Operation



5-Year Comprehensive Warranty



Easy Cleaning



Premium Commercial-Grade Materials





# IMPORTANT WARNING

## WARNING!

To minimize the risk of accidents, including electric shocks, personal injury, and damage resulting from improper use of the appliance, it is crucial to carefully read and strictly follow these instructions. By thoroughly reviewing the operating instructions, you will gain a better understanding of how to properly use the equipment. Please ensure that you and all other users of the appliance read these instructions in their entirety before operating the appliance.

## REMEMBER! YOUR PERSONAL SAFETY IS YOUR RESPONSIBILITY

### Assembly Procedures:

- Please take care to follow the assembly instructions closely and ensure that all attachments are positioned correctly.

### Important Safeguards:

The BFS450 Slicer is robust but can be damaged & dull blades by hard objects. For its longevity, remove pits from fruits like cherries, peaches, and plums before processing. Avoid inserting hard objects like whole nuts, thick bones, or frozen foods. Process semi-hard items like almonds in moderate amounts using suitable discs for optimal performance.

- Please exercise caution when unpacking the equipment and make sure to remove all attachments and specific items from their packaging.
- CAUTION - Please be careful while handling the equipment, especially the blades and discs as they are extremely sharp and may cause injury.
- We recommend you install your machine on a perfectly stable solid base.
- Ensure the slicer is in a stable position prior to operating. All four feet must be in contact with a secure level surface. Slicer must not be moved during operation.
- To avoid damage to the motor unit, always verify that your electrical supply matches the voltage and amperage specified on the identification plate.
- Do not use the slicer in the case where the power cord or plug shows any sign of damage, or if the appliance is working incorrectly, or has been dropped.
- Exercise caution when handling the blades, as they are highly sharp and can cause injury if not properly handled.
- Do not attempt to bypass the locking and safety mechanisms.
- Do not insert any object into the container where the food is being processed.
- Do not push the ingredients down with your hand.
- Do not put any external items/appliances such as spoons, knives or forks inside the slicer while it is operating.
- Never overload the appliance.
- Do not run the appliance when empty.
- Do not immerse the slicer in liquid or water. Ensure the slicer is away from all water services and never use the machine with wet hands or bare feet.
- Electrical repair must be done by an authorized dealer. Use only factory original parts and accessories. Modification of the slicer voids the warranty.
- Keep out of reach of children.
- Do not use any accessories that are not recommended by the manufacturer as it may cause damage or injury.
- Do not use while under the influence of drugs or alcohol.



# ASSEMBLY AND CHANGING THE DISCS

**CAUTION!** SLICER BLADES ARE SHARP

## ASSEMBLY

1. Place the discharge plate at the bottom with the motor base facing toward you.



Side A: For handling delicate citrus fruits or vegetables like tomatoes and mushrooms, position the ejection rib downwards.



Side B: For fine grating and slicing tasks, such as processing cabbage, celery, and other non-delicate fruits & vegetables, position the ejection rib upwards.

2. Assemble the discs

**WARNING!** THE DISCS ARE EXTREMELY SHARP. HANDLE WITH CARE.



a) **To assemble the slicing, grating, or julienne disc:** Place the disc onto the motor shaft and rotate it clockwise to ensure proper positioning.



(b.i) **To assemble the dicing unit:** Place the dicing grid on top of the food container, ensuring that it is properly aligned with the locking slot.



(ii) After fitting the dicing grid, place the corresponding slicing disc with a straight-edged blade on the motor shaft and rotate it in a clockwise direction to ensure proper positioning.

c) **Assemble the disc unit for French fries.** The French fries disc unit is comprised of a specific French fry slicing disc and a grid designed for French fries.



(i) Place the French fries grid in the food container, ensuring that it is correctly positioned with the French fries plate aligned with the outlet.



(ii) Fit the suitable French fries slicing disc onto the motor shaft and turn it in a clockwise direction to ensure that it is securely positioned.



3) Place the lid of the food container over the container and secure the hook as illustrated in the picture.

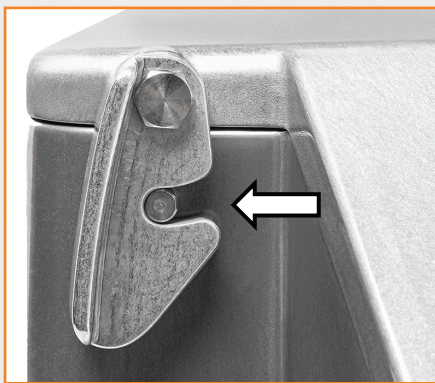

4) Lock the fastening hook.

## TO CHANGE THE DISCS

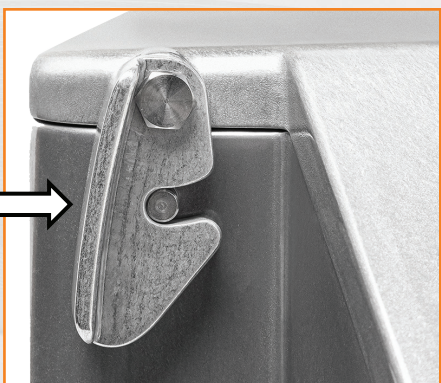

1. Unlock the fastening hook & open the food lid.
2. To remove the disc, turn it counterclockwise. For those using the dicing unit, it is recommended to remove the grid and the disc simultaneously.
3. Before fitting the dicing equipment, it's recommended to clean the inside of the food container with a damp cloth or sponge, especially the area where the grid is to be placed.
4. Please refer to the assembly instructions section to reinstall the disks.
5. Shut the lid and lock the fastening hook.

Always ensure that the grid is properly cleaned before use and avoid processing soft foodstuffs immediately after hard ones without cleaning the grid first.



## SWITCHING ON THE MACHINE

Prior to using the BFS450, confirm that your power source matches the BFS450's specifications on its identification plate. The BFS450 operates on a Single Phase/15A (Standard Household Outlet) 115V/60 Hz/60 Hz, and comes with a standard household plug for immediate and effortless operation.



## INSTRUCTION OF THE FEED INLETS

To ensure the best cutting quality, the machine's lid features two different feed inlets.

### **The wide feed inlet:**

Used for processing vegetables like cabbage, potatoes, and celery

### **The narrow feed inlet:**

Used for cutting long vegetables, can make sure the degree of cutting precision.

### **1. Using the wide feed inlet**

- Raise the pusher and turn it horizontally
- Fill the feed inlet with vegetables until it reaches the top.
- Rotate the pusher back to a horizontal position and then press it downward. Adjust the pressure to match the cutting process and avoid applying too much pressure as it may cause strain on the machine.
- For processing vegetables such as cabbages, it is recommended to cut them in half and remove the core before processing. This helps to avoid unnecessary stress and ensure a higher quality end product.

### **2. Using the narrow feed inlet**

- Fill the feed inlet with vegetables to the top and apply downward pressure on the feed pusher until all the vegetables are processed.



# DISCS AND ACCESSORY OPTIONS



## Slicer

Blade Sizes Available:

- 1/8"
- 1/4"
- 3/8"
- 1/2"
- 1"



## Dicer

Blade Sizes Available:

- 3/8" x 3/8"



## French Fries

Blade Sizes Available:

- 5/16" x 5/16"



## Julienne

Blade Sizes Available:

- 5/32" x 5/32"
- 1/4" x 1/4"
- 5/64" x 5/32"



## Grater

Blade Sizes Available:

- 1/16"
- 5/64"
- 1/8"
- 3/16"



## Ripple Slicer

Blade Sizes Available:

- 1/8"
- 1/4"



## Precision Tool Set

Includes:

- 3 x 0.7" Precision Cutting Tool
- 1.2" Precision Cutting Tool
- 1.8" Precision Cutting Tool



# CLEANING AND MAINTENANCE

## 1. CLEANING

**WARNING! ALWAYS UNPLUG THE MACHINE BEFORE CLEANING FOR SAFETY. RISK OF ELECTROCUTION.**

Disassemble the vegetable preparation machine, first remove the head, then remove the disc, and if necessary, remove the grid and discharge plate.

Hand washing with washing-up liquid is recommended for cleaning the machine to prevent the aluminum from becoming tarnished. While the disks are dishwasher safe, we suggest using a cleaner suitable for stainless steel to prevent them from tarnishing. Please note that the slicer machine itself should not be placed in the dishwasher, and should be cleaned by hand washing only using a suitable stainless steel safe detergent. \*Please take care when handling and washing disks as they are very sharp.

- Always disconnect the appliance from the power source before cleaning it.
- Ensure to clean the appliance and its attachments after each use.
- Do not submerge the motor unit in water.
- When cleaning parts made of aluminum, be sure to use cleaning fluids designed for aluminum. Likewise, avoid using detergents that are too alkaline (such as those containing high levels of caustic soda or ammonia) when cleaning plastic parts. Likewise, avoid using detergents that are too alkaline (such as those containing high levels of caustic soda or ammonia) when cleaning plastic parts as it will cause the plastic to deteriorate rapidly.
- The user is solely responsible for following the basic rules of cleaning and hygiene. BenchFoods cannot be held responsible for any failure to do so.

**WARNING! NEVER IMMERSE THE MOTOR BASE IN THE WATER, CLEAN IT WITH A DAMP CLOTH OR SPONGE.**

## 1. MAINTENANCE

Blades on slicing discs, plates on julienne discs, and the grating, dicing & French fry disks are all replaceable parts that need to be changed periodically to maintain high-quality cutting.

- To avoid the risk of electric shock, always disconnect the appliance from the power source before opening the motor housing for maintenance purposes.
- Regularly inspect the seals, washers, and safety devices to ensure they are functioning correctly.
- Regularly maintain and check the attachments, especially when processing ingredients that may contain corrosive agents such as citric acid.
- Always ensure that the appliance isn't used if the power cord or plug has been damaged or if the appliance does not function properly or has been damaged in any way.
- If you notice any issues with the appliance, please don't hesitate to contact your local BenchFoods representative.



# TECHNICAL SPECIFICATIONS

## WEIGHT

## ELECTRICAL DATA Single-phase machine

ITEM	NET	GROSS	MOTOR	INTENSITY (AMP)	SPEED (RPM)	OUTPUT
BFS450 complete	38.5 lbs	48.5 lbs	115V/60 Hz/60 Hz	12 A	450 RPM	660 lbs/hr
Average weight of one disc	1.3 lbs	1.5 lbs	<b>POWER RATING</b>	550W		

## DIMENSIONS (MM)

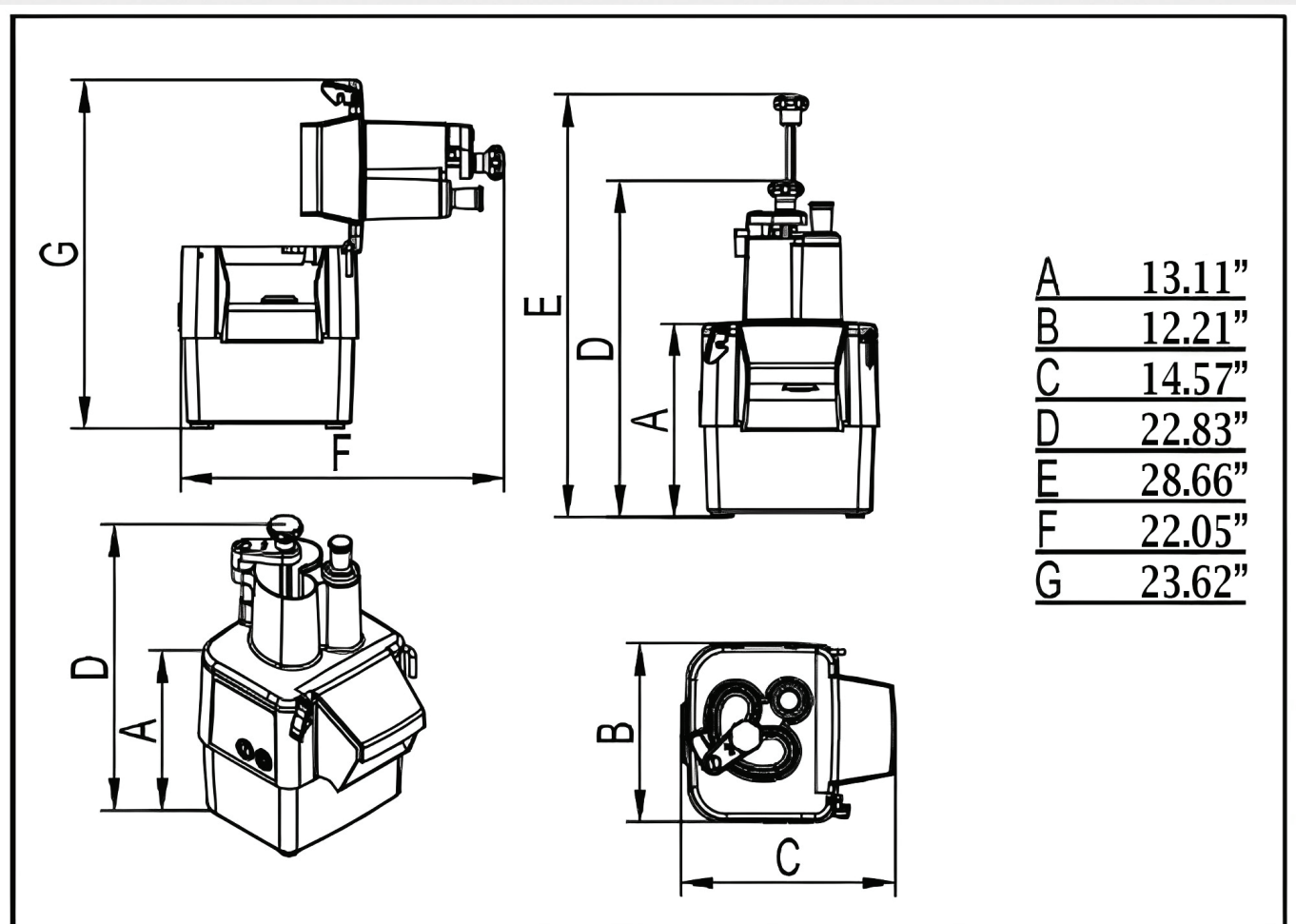

## WORKING HEIGHT

Place the equipment on a steady countertop, ensuring that the top border of the broad intake area is situated at an elevation at approximately 4' 3.2".

## NOISE LEVEL

While functioning without any load, the slicer generates a sound intensity of under 65 decibels.



# SAFETY INSTRUCTIONS

The device comes with a magnetic security mechanism that instantly halts the motor if the large feed inlet or lid is accessed. This protective attribute is intended to avert unintentional harm during the machine's functioning.

## **Auto restart function:**

By raising the large pusher and rotating it as indicated by the arrow, the machine's motor comes to a halt. If you return the pusher to its original position within a minute, the motor will resume operation automatically. Should the large pusher stay open for over a minute, you'll need to press the on/off button to reactivate the device.

To cease the device's operation, release the securing latch. To initiate the machine again, secure the latch and activate the on/off button.

## **The machine cannot be switched on if the fastening hook is not correctly locked.**

This machine features a thermal fuse that halts the motor if it becomes overburdened or operates for an extended duration. In such cases, allow the device to cool down entirely before attempting to restart it.



## **REMEMBER:**

- Never circumvent the safety and locking features.
- Keep from inserting items into the input opening while the machine is running.
- Utilize the pusher to exert pressure on the food being processed, rather than applying direct hand pressure.
- Avoid exceeding the device's designated load capacity.



# TROUBLE SHOOTING

SYMPTOM	REMEDY
<b>The machine isn't starting.</b>	First, check to ensure the machine is properly plugged in and the power switch is turned on. Also, ensure the lid is correctly placed and locked in position, as the safety features may prevent the machine from starting if it isn't properly secured.
<b>The machine is making a loud or unusual noise.</b>	Stop using the machine and unplug it. Check to see if there's anything lodged in the blades or the feed tube. If everything appears to be clear, please contact your customer service representative.
<b>The slicer isn't cutting evenly or cleanly.</b>	Check the blade for sharpness. If it appears dull or damaged, you may need to replace it. Also, make sure that the food is properly positioned in the hopper before processing.
<b>The motor seems to be overheating.</b>	Ensure the machine is not being overworked. If it continues to overheat with regular use, please contact your customer service representative.
<b>Food gets stuck in the machine.</b>	Make sure you're not overfilling the feed tube. If food continues to get stuck, consider cutting it into smaller pieces before processing.
<b>The machine is vibrating or moving during operation.</b>	Ensure the machine is on a flat, stable surface and the blades are in their correct locked position. If this continues please contact your customer service representative.
<b>The machine suddenly stopped during operation.</b>	Check if the machine is overheated. If it is, allow it to cool down before restarting. If it's not overheating, check to ensure the lid is properly locked and there's no blockage in the feed tube or blades.



# 5 YEAR COMPREHENSIVE WARRANTY

This Warranty applies to all physical goods (product/s) purchased from the company BenchFoods.

## 1. WHAT DOES THIS WARRANTY COVER?

This Comprehensive Warranty covers any defects in material or workmanship under normal commercial use during the Warranty Period. During the Warranty Period, BenchFoods or your Authorized Retailer will repair, at no charge, products or parts of a product/s that prove defective under normal commercial use.

## 2. WHAT WILL WE DO TO CORRECT PROBLEMS?

BenchFoods or your Authorized Retailer will action 1 of 3 scenarios based on the defect and the product purchased;

1. Send a brand-new replacement of the defective product. \*Does not apply for custom industrial orders
2. If the defective part of the product can be identified, we will ship the replacement part and have a service technician come on-site to replace and install it once it has arrived.
3. Send out a service technician to investigate the defect. Once the issue has been identified, the technician will either fix the defect immediately or notify BenchFoods of replacement parts needed. If the latter, BenchFoods will ship the required replacement parts to the service address. The technician will then return on-site to service and fix the product.

## 3. HOW LONG DOES THE COVERAGE LAST?

The Warranty Period for BenchFoods products, as well as their accessories, is 5 years from the original date of purchase. Individual Parts purchased are not covered by warranty unless they are received through a warranty claim on a previously purchased product. In this case, a replacement product or part/s assumes the remaining warranty of the original Physical Goods or 180 days from the date of replacement or repair, whichever is longer.

## 4. WHAT DOES THIS WARRANTY NOT COVER?

This Commercial Warranty does not cover defects or malfunction caused by misuse, abuse or improper maintenance, failure to follow operating instructions, or use with equipment with which it is not intended to be used. It doesn't cover cosmetic or incidental damages. Also, the warranty will not apply to damage caused by unauthorized alteration, modification or repair of the product.

## 5. WHAT DO YOU HAVE TO DO?

To obtain warranty service, firstly contact us to determine the problem and the most appropriate solution for you. In most cases, technical problems can be corrected over the phone. Tech support can be reached via telephone or email.

**Tel:** **US:** (972) 737-1282 **CA:** (604) 800-7466 **UK:** 0203 879 4355

**AU:** (07) 3184-4335 **NZ:** (09) 870-3320

**Email:** [info@benchfoods.co](mailto:info@benchfoods.co)



# NOTES SECTION



# BENCHFOODS

---

**UNITED STATES:**

(972) 737-1282 | 4514 MAXEY RD, SUITE A - D,  
ALVARADO, TX, 76009

**CANADA:**

(604) 800-7466 | SUITE 900/2025 WILLINGDON AVE,  
BURNABY, BC V5C 0J3

**[INFO@BENCHFOODS.CO](mailto:INFO@BENCHFOODS.CO)**

**[BENCHFOODS.CO](https://www.benchfoods.co)**