

ASSEMBLY INSTRUCTIONS

1270040

HARDWARE

Ax6



M6 x 60 mm

Bx6



Ø17 x 1.5 mm

Cx6



Ø13 x 1.5 mm

Dx1



4 mm

PARTS

1x1



2x2

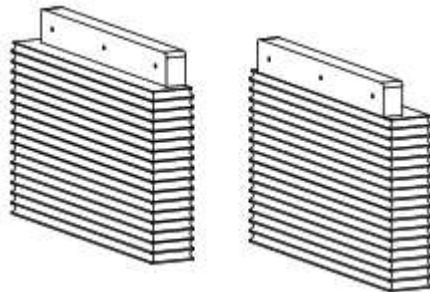

(1)

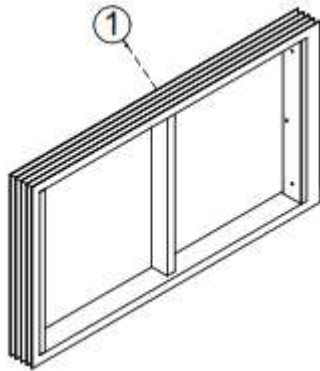

- Place Top (1) in the position as shown in the picture.

(2)

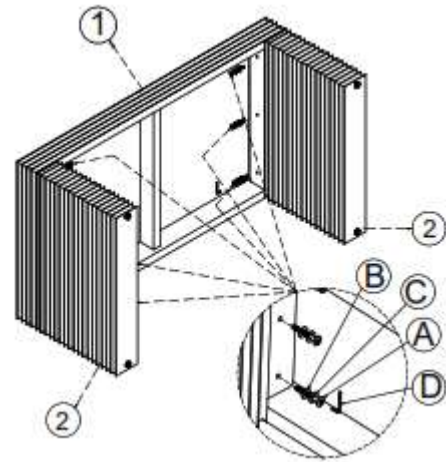

- Place the legs (2) in the holes provided on the side of the top (1), then insert the Bolt (A) with the Flat Washer (B) and Spring Washer (C) then tighten with the Allen key (D).
- Do the same with the other legs.

(3)

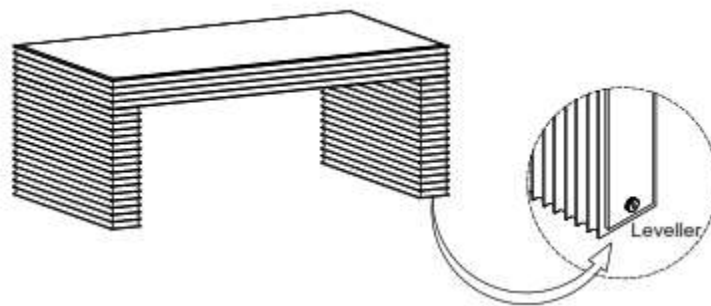

A Leveler is provided at the bottom of the leg to balance on uneven surface

- Completed