

Assembly Instructions

Cushions may vary for different SKUs



For any missing hardware, damaged parts and other problems.
WELCOME to email us.

***Don't fully tighten all the bolts till the very end!**

PRE-ASSEMBLY PREPARATION:

- A cordless drill is recommended for ease of assembly.
- Clear out the space for assembly and lay out all of the parts based on the Parts List, extra room will allow you to easily determine if all the pieces are present.
- Keep small parts and pieces away from children until fully assembled.

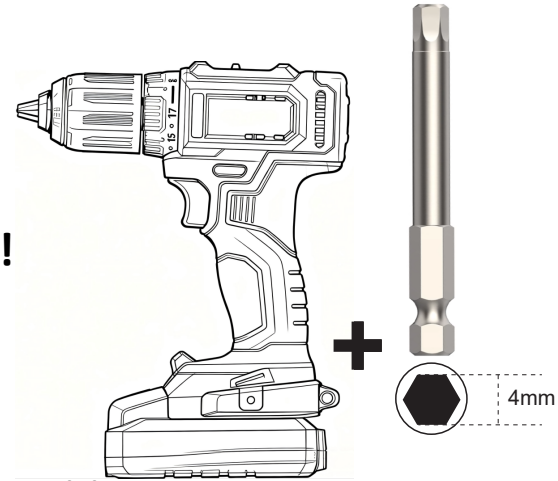

A1

Left
arm
1 pc

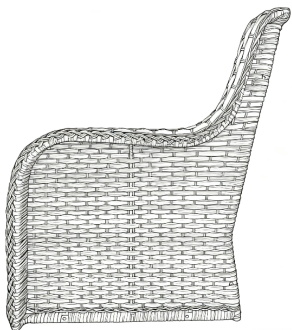

C

Seat
1 pc

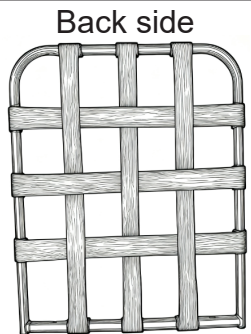

D

Front
panel
1 pc

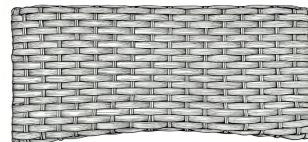

A2

Right
arm
1 pc

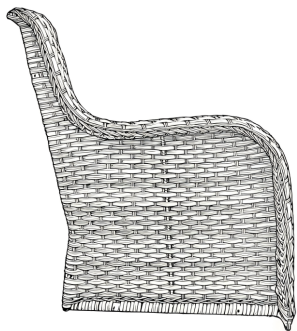

P

Back
Cushion
1 pc

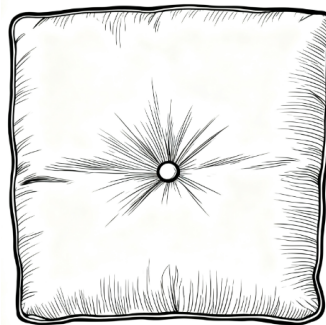

B



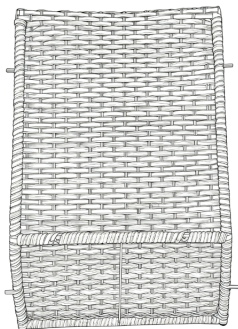

Back
1 pc

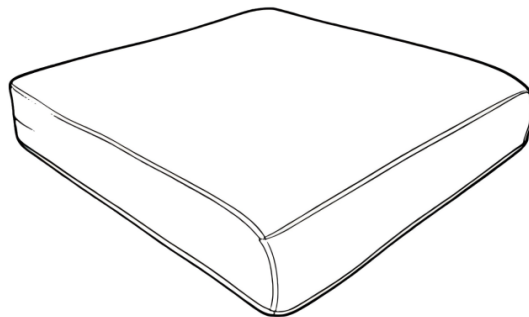

O

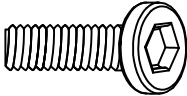
Seat
Cushion
1 pc

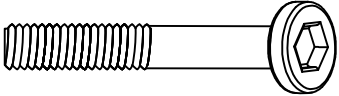

No.	Part/Size	QTY	Image	No.	Part/Size	QTY	Image
H	Bolt (M6*15mm)	4	<p>**Actual Scale</p> 	J	Wrench	12	
I	Bolt (M6*35mm)	8	<p>**Actual Scale</p> 	M	Allen Wrench	1	

Step 1 : Attach left arm A1 to back B with 2pcs bolts H , 2pcs washers J , using Allen wrench M .



**Actual Scale



Note: Don't fully tighten the bolts !

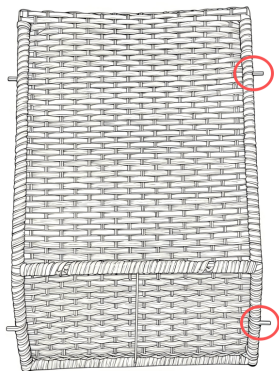
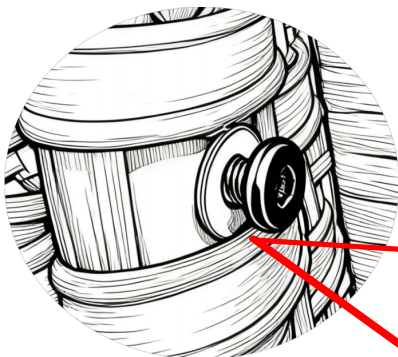

B Chair back

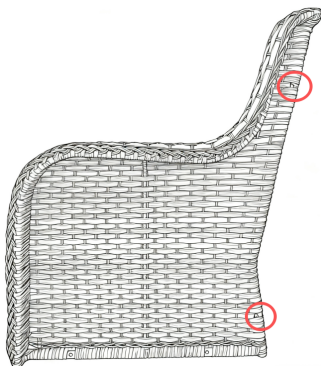

A1 Left Arm

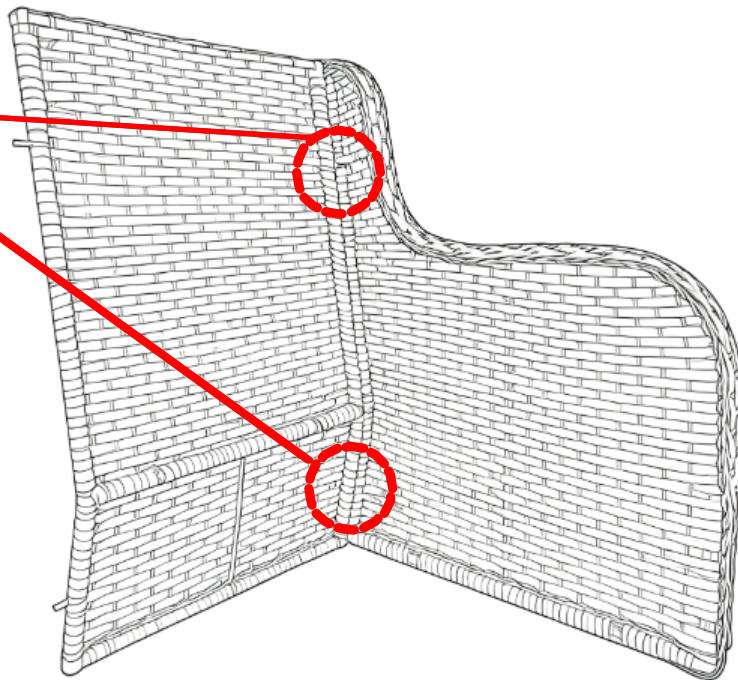

Step 2 Attach right arm A2 to back B with 2pcs bolts H ,2pcs washers J ,using Allen wrench M .

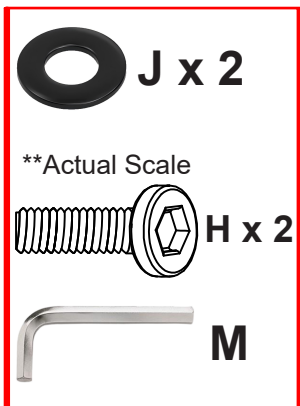

Note:Don't fully tighten the bolts !

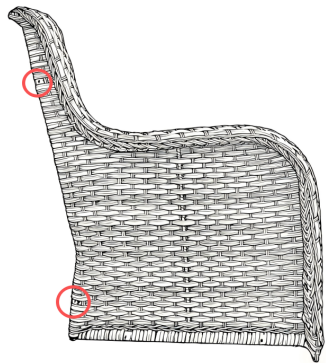
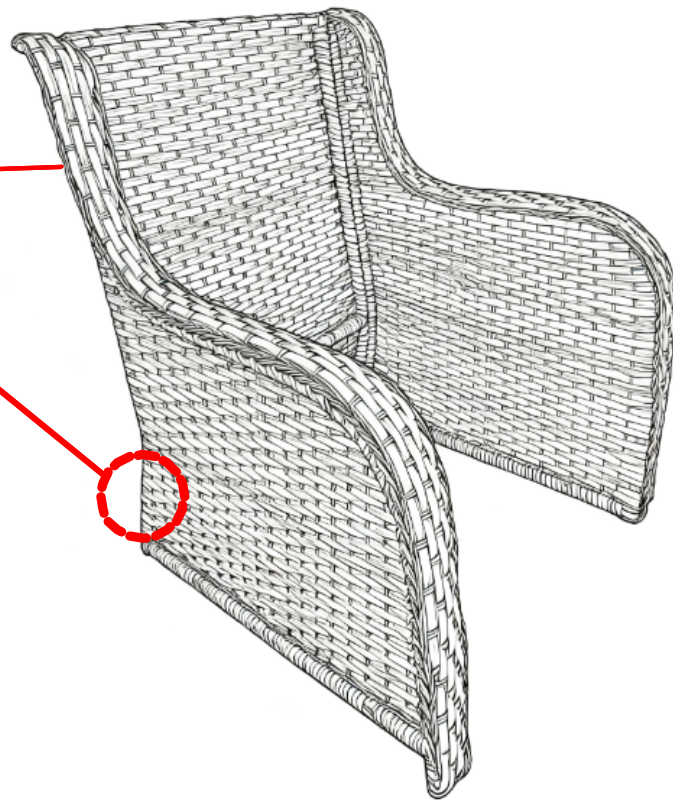
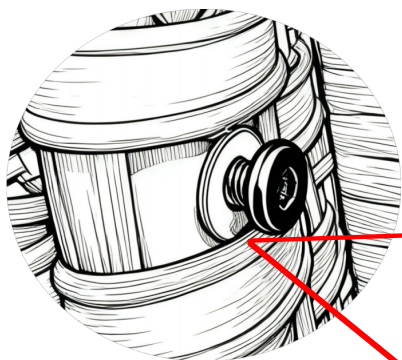

A2 Right Arm

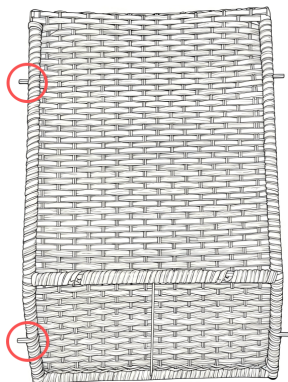

B Chair Back

Step 3 Attach seat C to front D with 2pcs bolts I and 2pcs washers J, using Allen wrench M.

Note: Don't fully tighten the bolts !



**Actual Scale

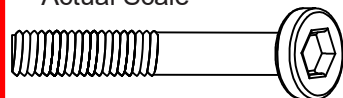

I x 2

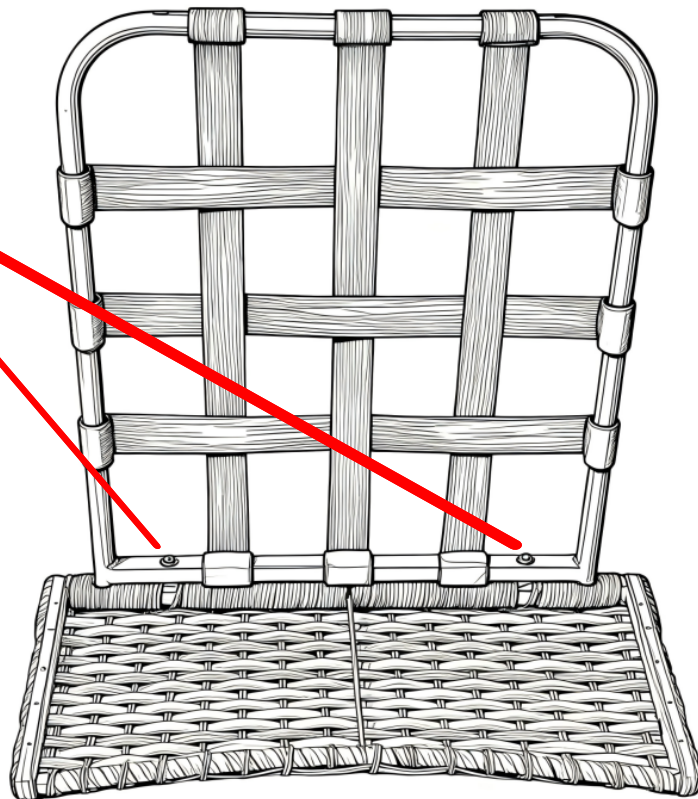
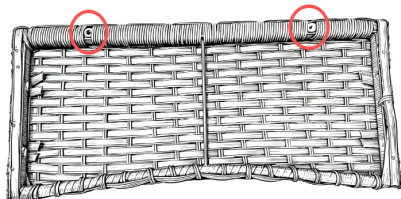
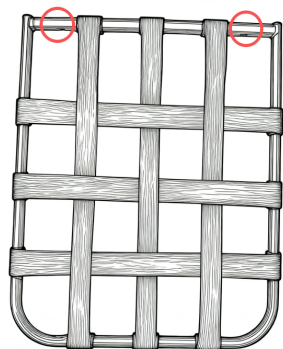
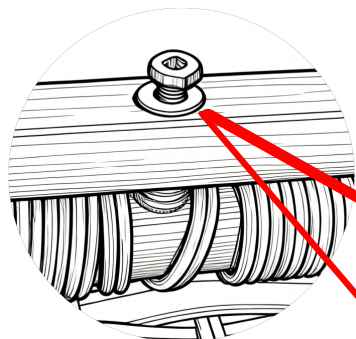

Step 4: Attach front panel D to left armrest A1 with 2pcs bolts I and 2pcs washers J, using Allen wrench M. Then rotate 180 degrees attach right armrest A2 in the same way .

Note: Don't fully tighten the bolts !

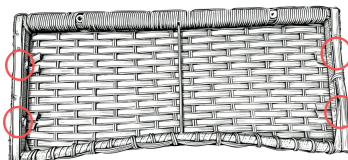
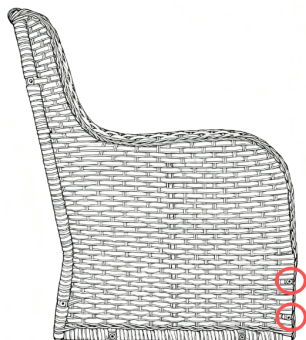
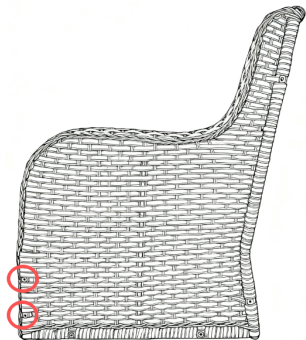
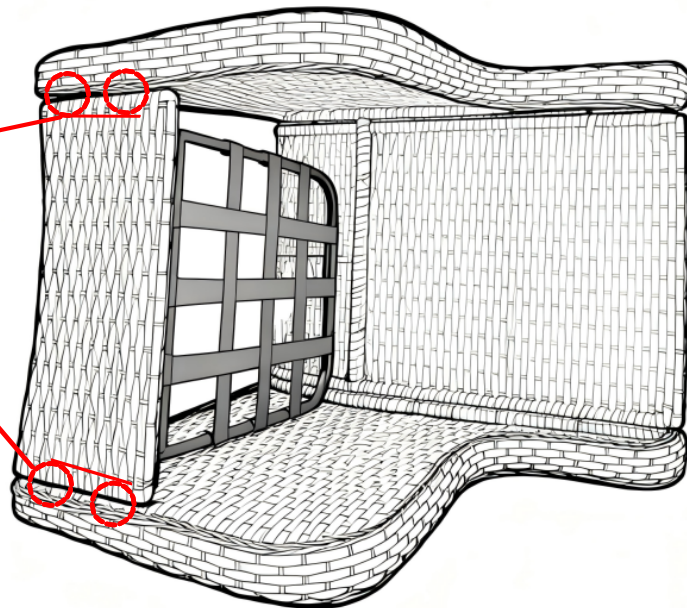
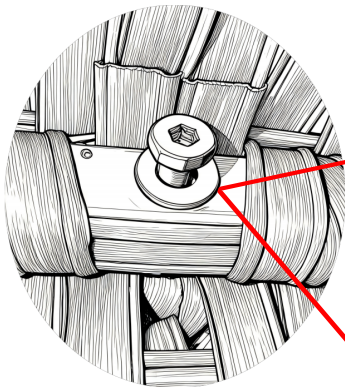
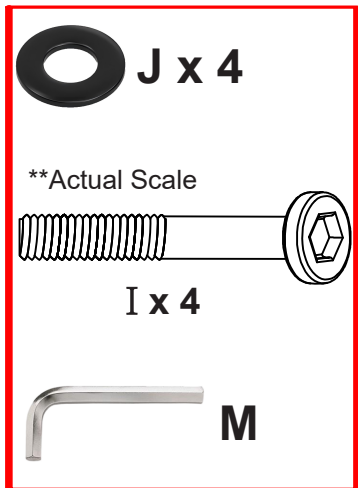

Step 5 : Attach seat C to back B with 2pcs bolts I and 2pcs washers J ,using Allen wrench M.

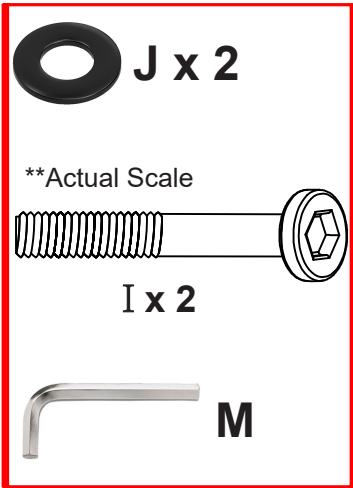

Note:Don't fully tighten the bolts !

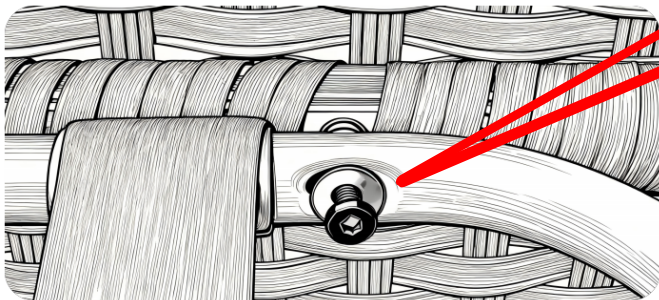
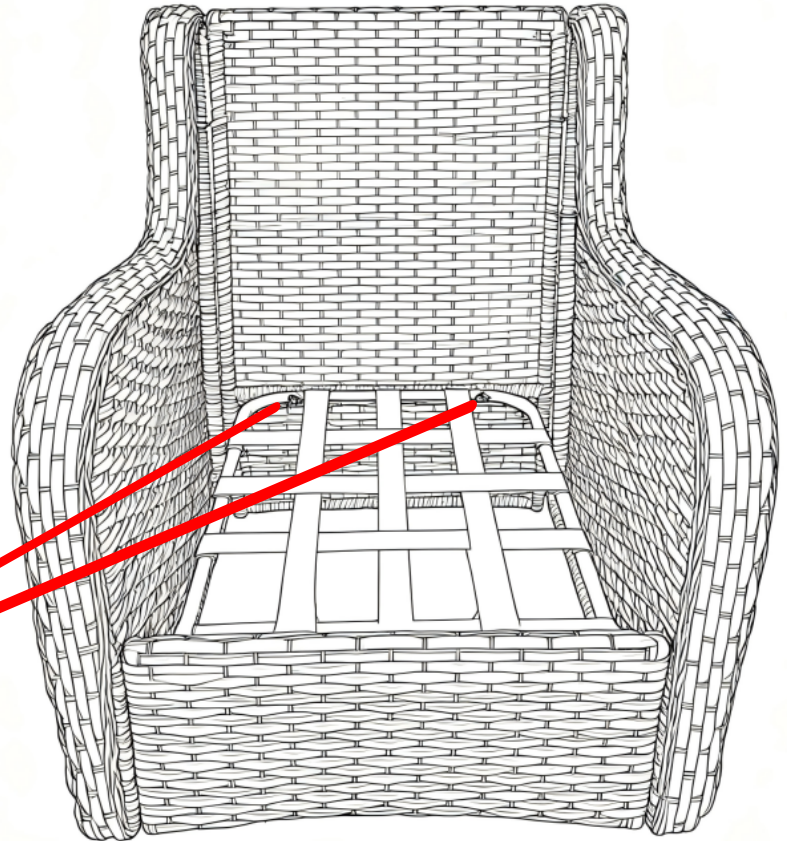
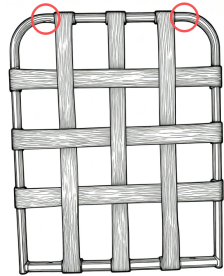
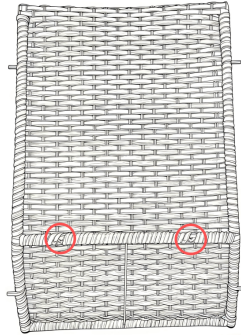

Step 6

Keep cushion core and cover directions consistent .

Align the two sides of the cushion core with the two sides of the cover .

Put seat cushion core into the cover .

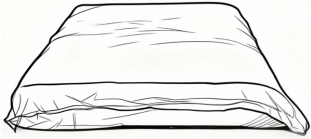

The rounded corners are on the front.

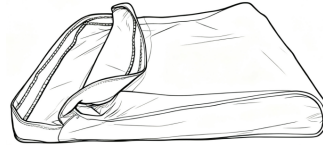

When inserting the cover, keep the two sides aligned .



Pull the cover back

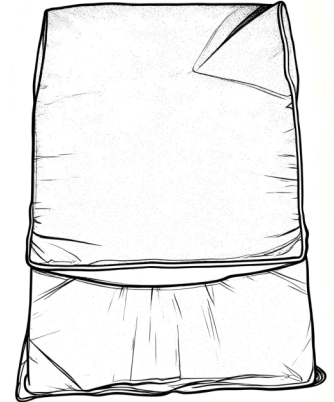

The index finger presses on the cushion core. The other fingers pinch the cover. Then another hand zip up the cover .

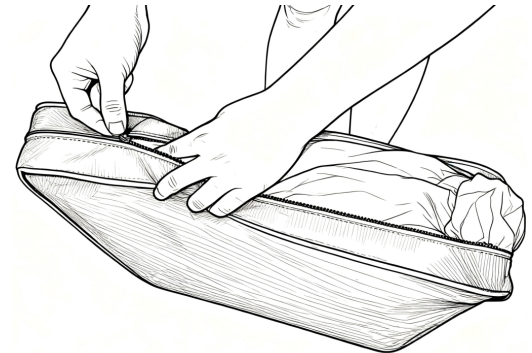

Step 7

Put seat and back cushion onto the chair and take care the cushions .

The installation is not yet complete. Please do not use the chair .

Do not tighten the bolts ! After receiving the base, connect the chair to the base.

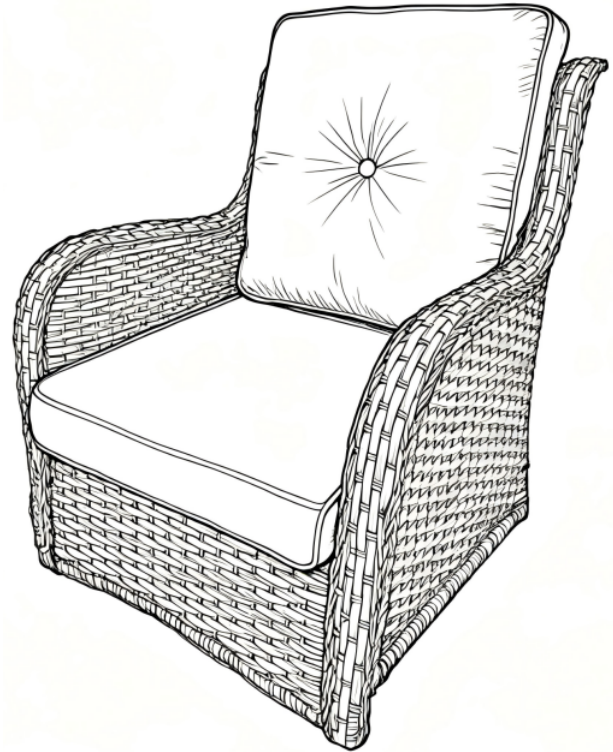
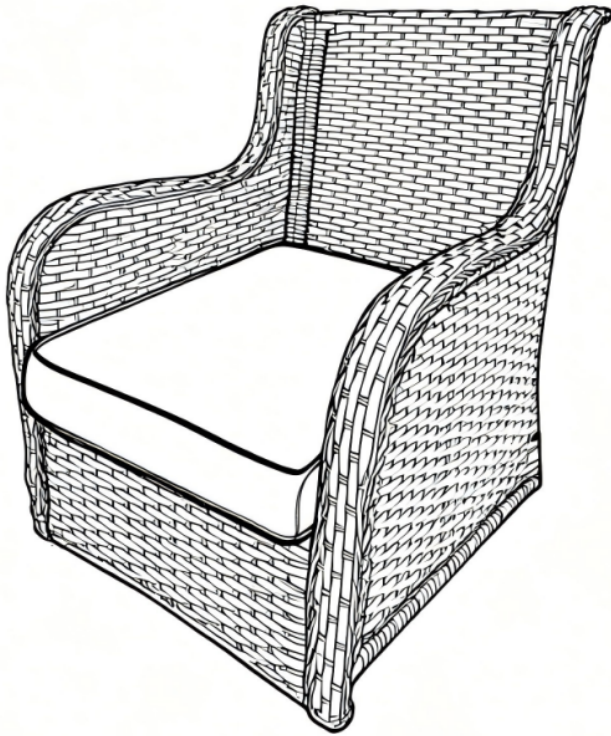

Q & A:

Q: Frame drilling holes not align?

A: If discrepancy less than 1/8 in., please loosen other relative bolts first, then adjust parts position and re-tight all bolts.

if discrepancy more than 1/4 in., it should be parts deformation during violent transportation, please contact us for parts replacement.

Q: Why cushion shrink packing and how to help it rebound faster?

A: We shrink packing cushion is to improve product value to cost, because it can save transport cost a lot. We filled it with more and high-quality filling than normal cushion to make sure it can be fully rebound.

Q: Coffee table legs un-even?

A: Loosen bolts, then press table downwards, then tighten bolts again. If it can not solve problem, please contact us for parts replacement.

Q: Wicker colors different on parts?

A: We make wicker stripes to fit for nature environment, colors may various circularly. So when those wicker stripes hand-woven on product randomly, it may looks different on parts.

Q: Why some swivel plate not work well?

A: Swivel plate may need a running-in period like 10~20 cycles. If it still not swivel well, please contact us for swivel plate replacement.

Q: Bolts are not long enough for assembly sometimes?

A: Sometimes gaps maybe larger than the bolts to reach out when assembly, please contact us for longer bolts. After all, those parts are woven by hand-made. But after it assembled and all bolts tightened, the gaps will be disappeared, because wicker parts are flexible surface.

Q: Parts received damaged?

A: Although we had already did our best to pack products well, there are also unpredictable transport damages accident happened from time to time. When it happens, please contact our after-sales email, state the order number/which shopping platform it comes from/one of the parcel tracking number, and provide the relevant pictures of the problem, we will immediately provide you with a suitable replacement parcel.

Q:Received item but missing hardware or parts

A:Please contact our after-sales email, state the order number/which shopping platform it comes from/one of the parcel tracking number, and provide the relevant pictures of the problem, we will immediately provide you with a suitable replacement parcel.

How to take care of the product

1. Maintain your outdoor furniture by using furniture covers or storing out of the elements when not in use.

2. Wicker: Wipe surface dust with warm water

3. Frame: Clean frames with a mild soap and warm water, rinse with clean water and dry thoroughly. Do not use abrasive materials or strong detergents

4. Fabric: Clean with mild soap and water. Do not put cushions in dryer.

5. In cold climates, drain any water accumulated inside the frames before storing.