

2 BASKET DRIFTWOOD
CONSOLE AVEC DEUX PANIERS EN BOIS DE GRÈVE
CREDENZA CON DOS CANASTAS DE MADERA DE FLOTACIÓN

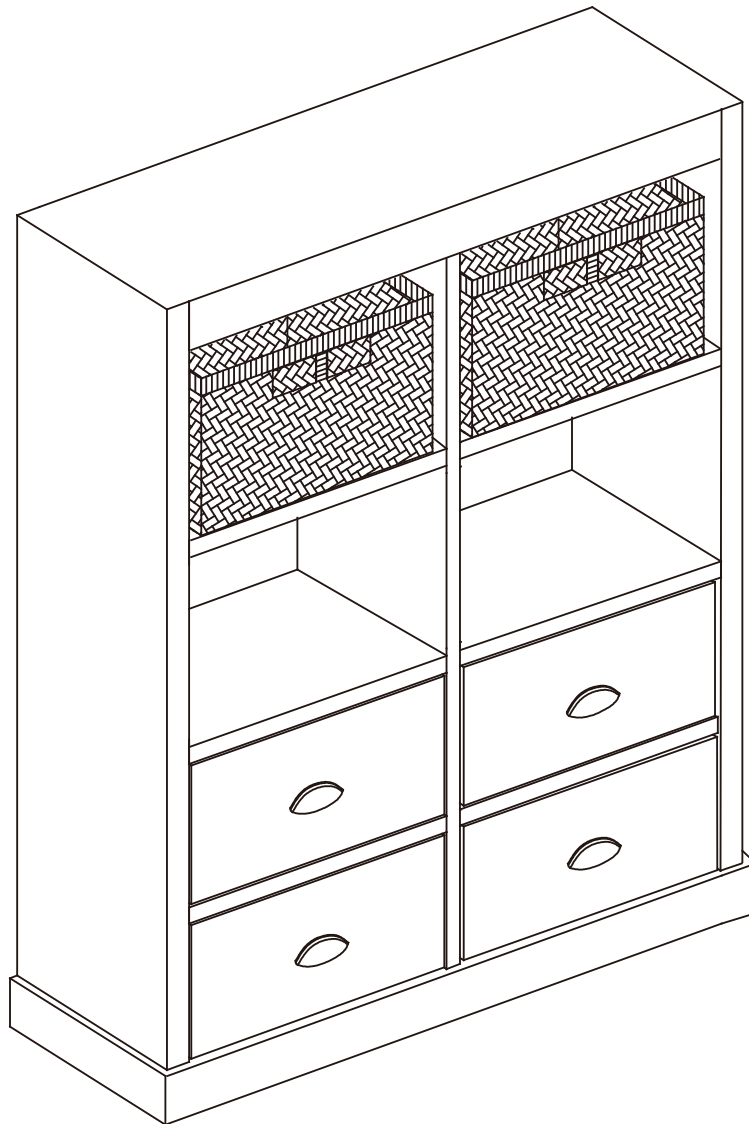

We are here to help!
Before you return it - contact us.

Nous sommes là pour vous aider!
Avant de retourner le produit, veuillez communiquer avec nous.



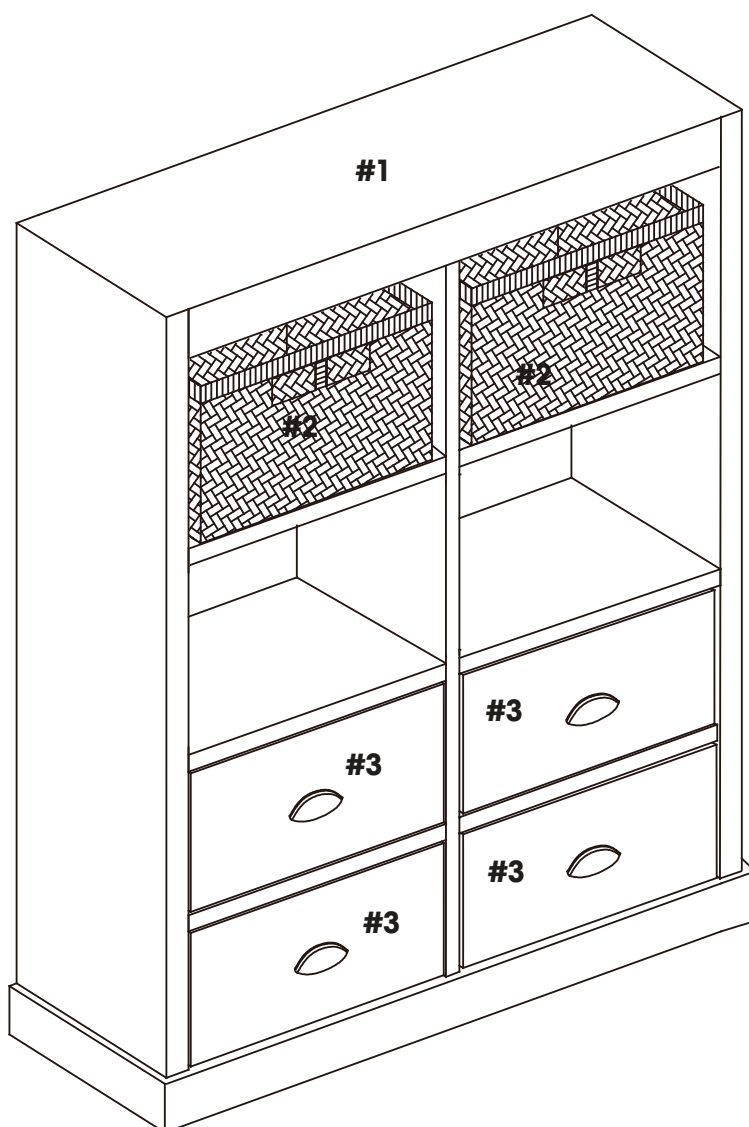

¡Estamos aquí para ayudarle!
Antes de regresar el producto, comuníquese con nosotros.

PART LIST

#1	CONSOLE	01
#2	BASKET	02
#3	DRAWER	04



HARDWARE LIST

A	WALL ANCHOR		04
B	WALL SCREW (Ø3/16"X2")		04
C	STRAP		02
D	MOUNTING PLATE		02

TOOLS REQUIRED

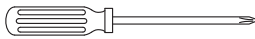
PHILIPS SCREWDRIVER		NOT SUPPLIED
---------------------	--	--------------

IMPORTANT:

1. Do not tighten bolts completely until all bolts are completely lined up and inserted into holes / nuts.
2. Do not over tighten screws and bolts to avoid stripping.
3. Please use hand tools to assemble this product. Do not use power tools.

1.

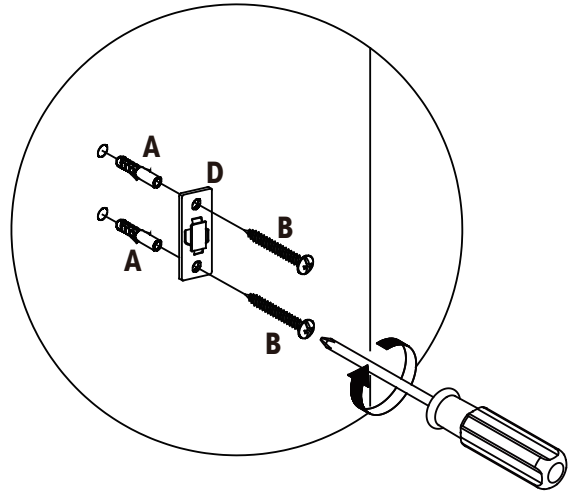
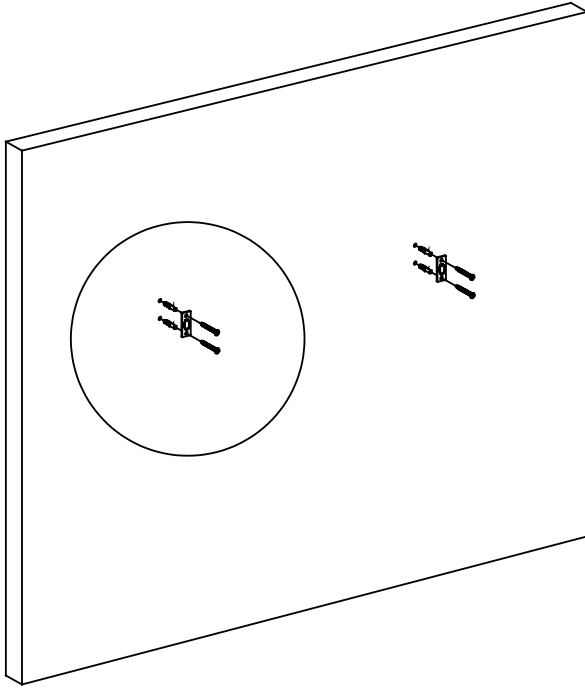

A		04
B		04
D		02

2.

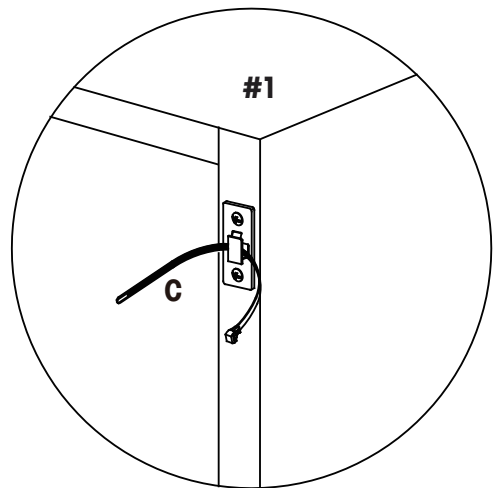
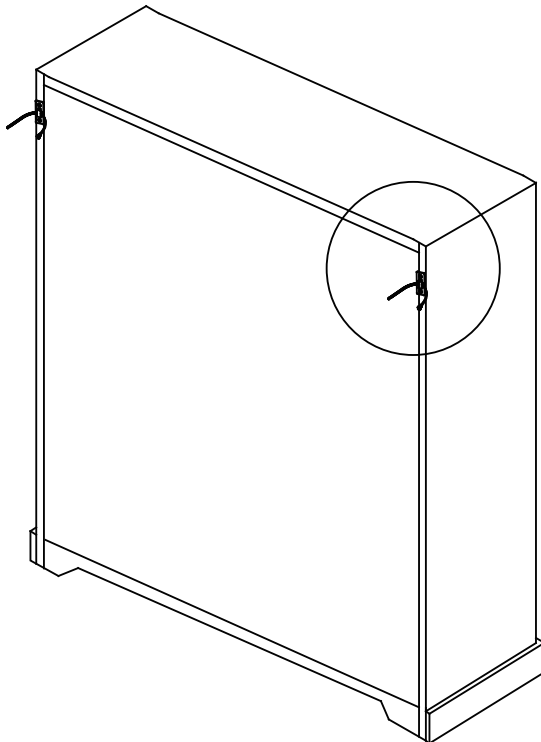

C		02
---	--	----

3.

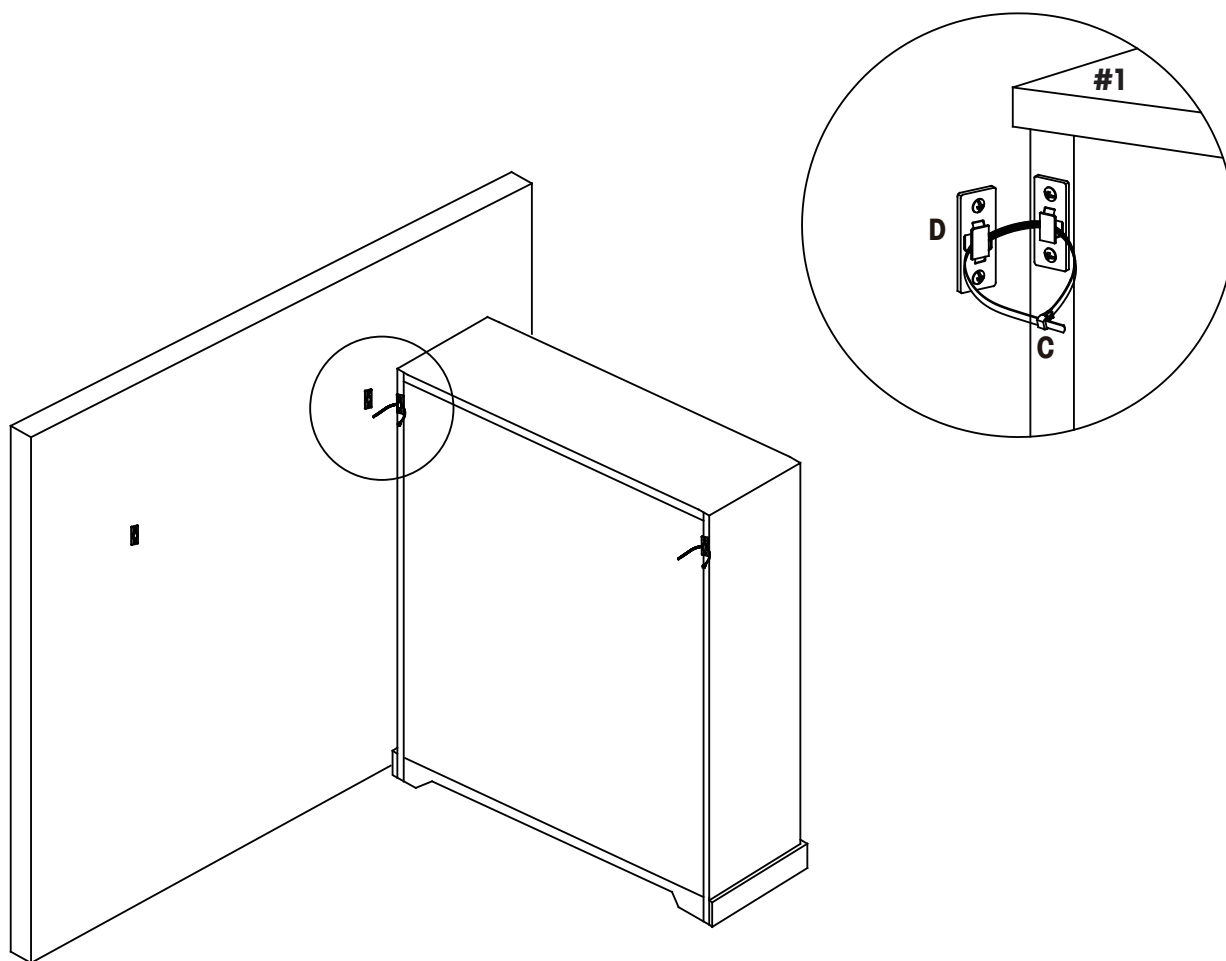

4.

WARNING

Serious or fatal crushing injuries can occur from furniture tipover. To help prevent tipover:

- Install tipover restraint provided.
- Place heaviest items in the lower drawers.
- Unless specifically designed to accommodate, do not set TVs or other heavy objects on top of this product.
- Never allow children to climb or hang on drawers, doors or shelves.
- Never open more than one drawer at a time. (OR)
- Do not defeat or remove the drawer interlock system.

Use of tipover restraints may only reduce, but not eliminate, the risk of tipover.

This is a permanent label. Do not remove.

AVERTISSEMENT

Le basculement du meuble peut causer de graves blessures par écrasement, voire la mort. Pour empêcher le basculement:

- Installer les dispositifs antibasculement fournis.
- Ranger les articles les plus lourds dans les tiroirs du bas.
- À moins qu'il ne soit conçu à cette fin, éviter de placer un téléviseur ou un objet lourd sur le dessus de ce meuble.
- Ne jamais permettre à des enfants de monter sur les tiroirs, portes ou tablettes, ni de s'y suspendre.
- Ne jamais ouvrir plus d'un tiroir à la fois. (OU)
- Ne pas altérer ni retirer le système de verrouillage du tiroir.

L'utilisation d'un dispositif antibasculement ne peut que diminuer, et non éliminer, le risque de basculement.

Cette étiquette est permanente. Ne pas tenter de l'enlever.

ADVERTENCIA

El vuelco del mueble puede causar lesiones por aplastamiento e incluso la muerte. Para evitar que el mueble se vuelque:

- Instale los dispositivos antivuelco proporcionados.
- Guarde los artículos más pesados en los cajones inferiores.
- Evite colocar un televisor o un objeto pesado encima del mueble, salvo si éste último ha sido diseñado específicamente para dicho fin.
- No permita que los niños suban sobre los cajones, las puertas o los estantes ni que se cuelguen de dichas piezas.
- No abra más de un cajón a la vez. (O)
- No altere ni quite el sistema de cerradura del cajón.

El uso de un dispositivo antivuelco sólo disminuye el riesgo de vuelco, no lo elimina.

Esta etiqueta es permanente. No trate de quitarla.

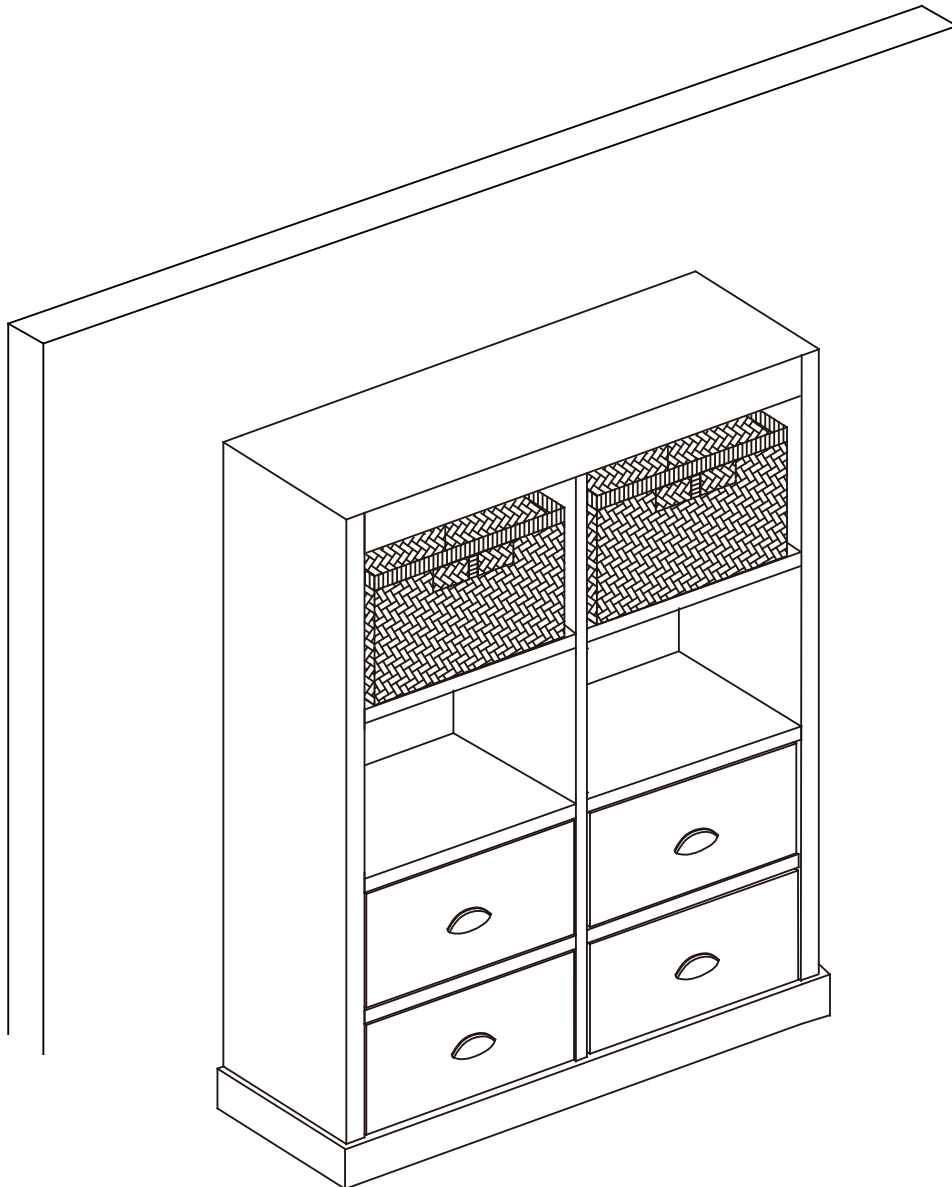

LIMITED WARRANTY

GARANTIE LIMITÉE

GARANTÍA LIMITADA

MADE IN CHINA
FABRIQUÉ EN CHINE
HECHO EN CHINA

