

HAPPINESS HAPPINESS INSTALLATION

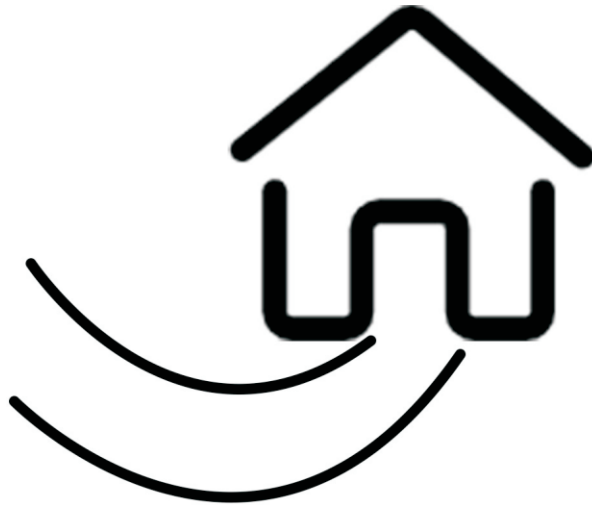

- If you have any questions with the product, please contact us by:
- **Email: customerservice@zoy-living.com**
(we will reply to you within 24 hours)



Assembly Instructions

8079

Your chair comes packaged in one box. Carefully remove all of components from the packaging and set aside for assembly.

CAUTION:
DO NOT use any sharp objects
To open plastic wrapped
Components as damage to
Product or components may
Result

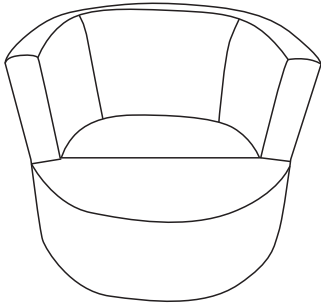
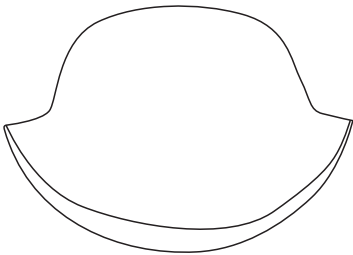
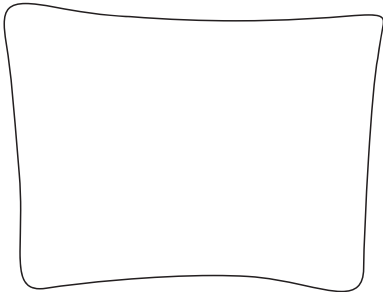
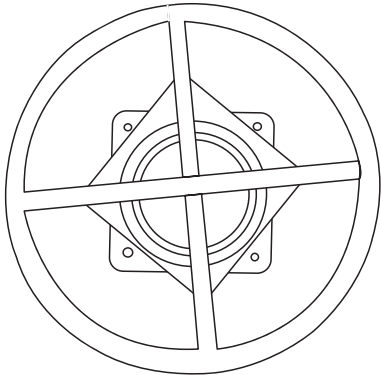
Package Contents

Ax1 	Bx1 	Cx1 
Dx1 	Ex1 	Fx4  M6x20mm

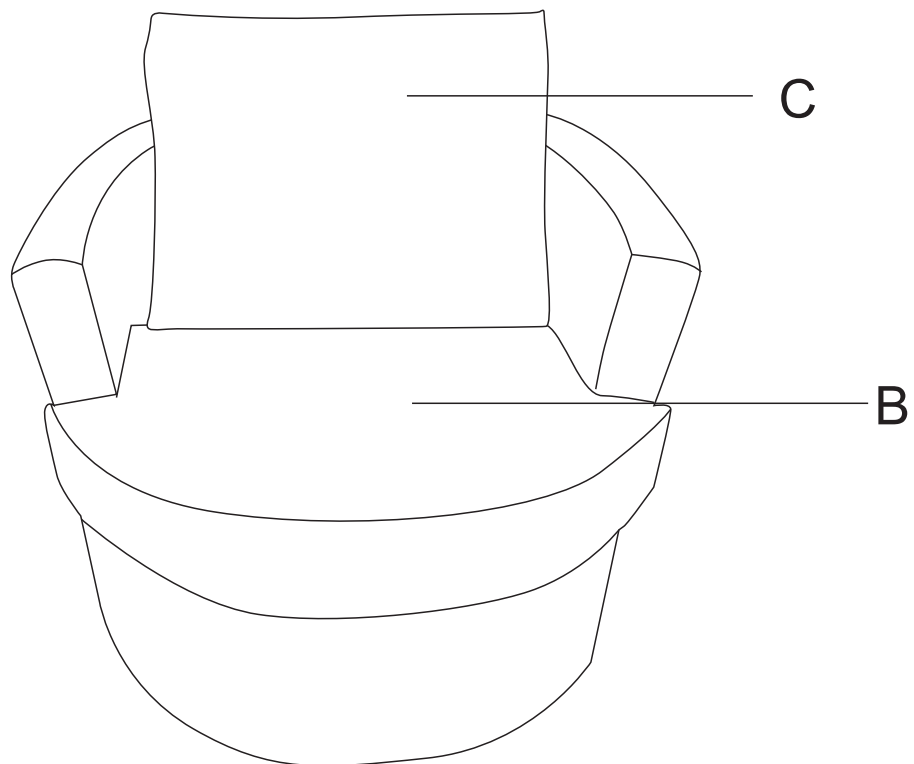
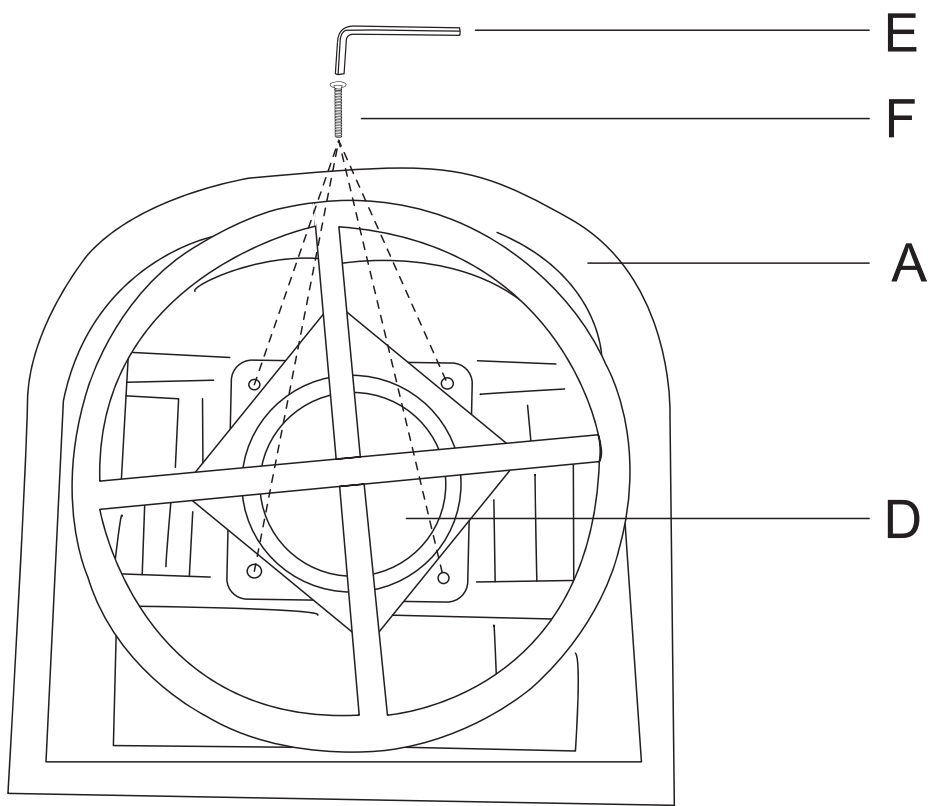

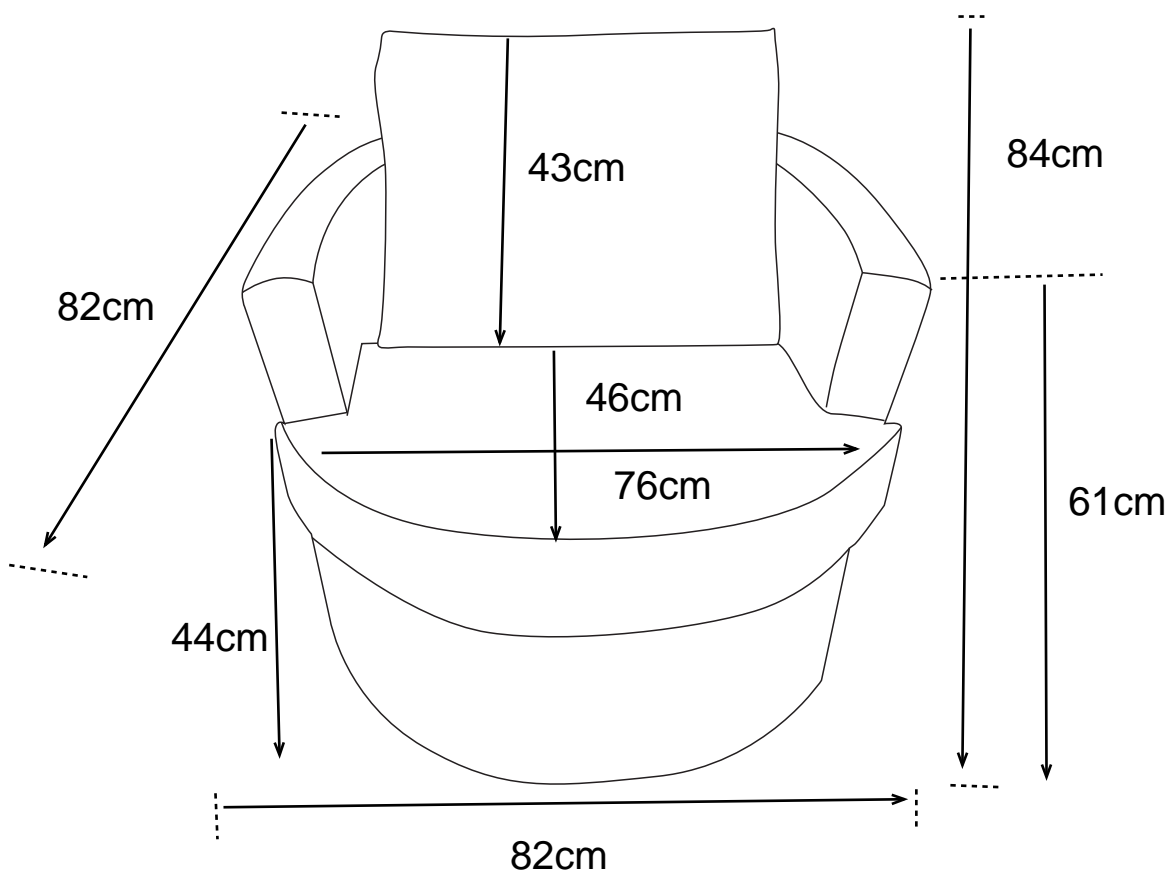

Warnings

1. Please check if the components of the chair are all included and can be used normally.
2. Assemble all components according to the instruction correctly before you connect the chair to the power.
3. Please DO NOT sit on the armrests or footrest to eliminate the risk of tipping over.
4. If the chair is damaged or doesn't match the website description, please send clear pictures of the product and label of the carton to our service team for further help.
5. If the recliner doesn't work, you may try the following measures for self-checking firstly:
 - a) Check if all the cables are connected;
 - b) Check if the light of transformer is on.

If the chair still doesn't work, please feed the information back to our customer service in time and we'll help you solve the matter as soon as possible.

6. If you have any questions with the product, please contact us by:

Email: customerservice@zoy-living.com (we will reply to you within 24 hours)

