

Features

- *ExoCrylic™*
- *Oval shape*
- *Drop-in installation*
- *Six individually adjustable ProFlex® hydro-massage jets*
- *Pump with air switch and grounding-type plug-in cord*
- *In-line heater*
- *Molded lumbar support and armrests for comfort*
- *Optional K-9696 whirlpool trim kit in additional finishes*
- *Custom pump locations*
- *60" (1524 mm) x 40" (1016 mm) x 17-5/8" (448 mm)*

Codes/Standards Applicable

Specified model meets or exceeds the following:

- *ASME A112.19.7/CSA B45.10*
- *CSA B45.5/IAPMO Z124*
- *UL 1795*

CUSTOM WHIRLPOOL BATH WITH HEATER

K-1146-HK ALSO K-1146-HN

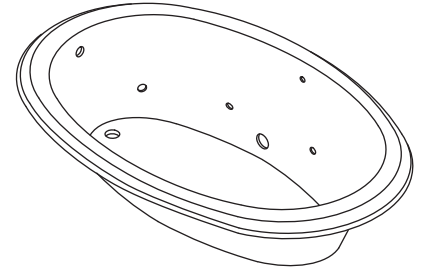

Colors/Finishes

- 0: White
- Other: Refer to Price Book for additional colors/finishes

Accessories

- 0: White
- CP: Polished Chrome
- PB: Vibrant® Polished Brass
- Other: Refer to Price Book for additional colors/finishes

Specified Model

Model	Description	Colors/Finishes	
K-1146-HK	Custom whirlpool bath with heater – drop-in (top view shown)	<input type="checkbox"/> 0	<input type="checkbox"/> Other _____
K-1146-HN	Custom whirlpool bath with heater – drop-in	<input type="checkbox"/> 0	<input type="checkbox"/> Other _____

Optional Accessories			
K-1491	Removable bath pillow	<input type="checkbox"/> 0	<input type="checkbox"/> Other _____
K-1601	Removable footstop	<input type="checkbox"/> 0	<input type="checkbox"/> Other _____
K-9696	Jet trim kit (metal finishes)	<input type="checkbox"/> CP	<input type="checkbox"/> PB <input type="checkbox"/> Other _____

Product Specification

The ExoCrylic whirlpool bath shall be 60" (1524 mm) in length, 40" (1016 mm) in width, and 17-5/8" (448 mm) in height. Whirlpool shall be oval shaped and for drop-in installation. Whirlpool shall have six individually adjustable ProFlex hydro-massage jets, pump with air switch and grounding-type plug-in cord, and in-line heater. Whirlpool shall have custom pump locations, and molded lumbar support and armrests for comfort. Whirlpool shall have an optional K-9696 whirlpool trim kit in additional finishes. Whirlpool bath shall be Kohler Model K-1146-____-_____.

PROFLEX® 6040

Technical Information

Fixture*:	
Bathing well:	
Basin area, bottom	46" (1168 mm) x 19" (483 mm)
Basin area, top	55" (1397 mm) x 29" (737 mm)
Weight	61 lbs (27.7 kg)
To overflow:	
Water depth	14" (356 mm)
Capacity	54 gal (204.4 L)
* Approximate measurements for comparison only.	

Pump:	V	Hz	A	
1-speed	120	60	7.5	
Heater:	KW	V	Hz	A
	1.5	120	60	12.5
* Approximate measurement for comparison only.				

Included components:	
Cutout template	114859-7

Required Electrical Service

Two dedicated circuits required, each protected with Class A Ground-Fault Circuit-Interrupter (GFCI):	
Pump/control	120 V, 15 A, 60 Hz
Heater	120 V, 15 A, 60 Hz
Locate the outlets behind the whirlpool and within 24" (610 mm) of the pump and heater.	

Installation Notes

Install this product according to the installation guide.

Floor support under whirlpool must provide for a minimum of 33 lbs/square foot (158 kg/square meter) loading.

The suction line extends 1" (25 mm) beyond the edge of the rim. The pump base extends 1-1/8" (29 mm) beyond the edge of the rim. Modify the framing as needed.

No change in measurements if connected with the drain illustrated. (K-11677)

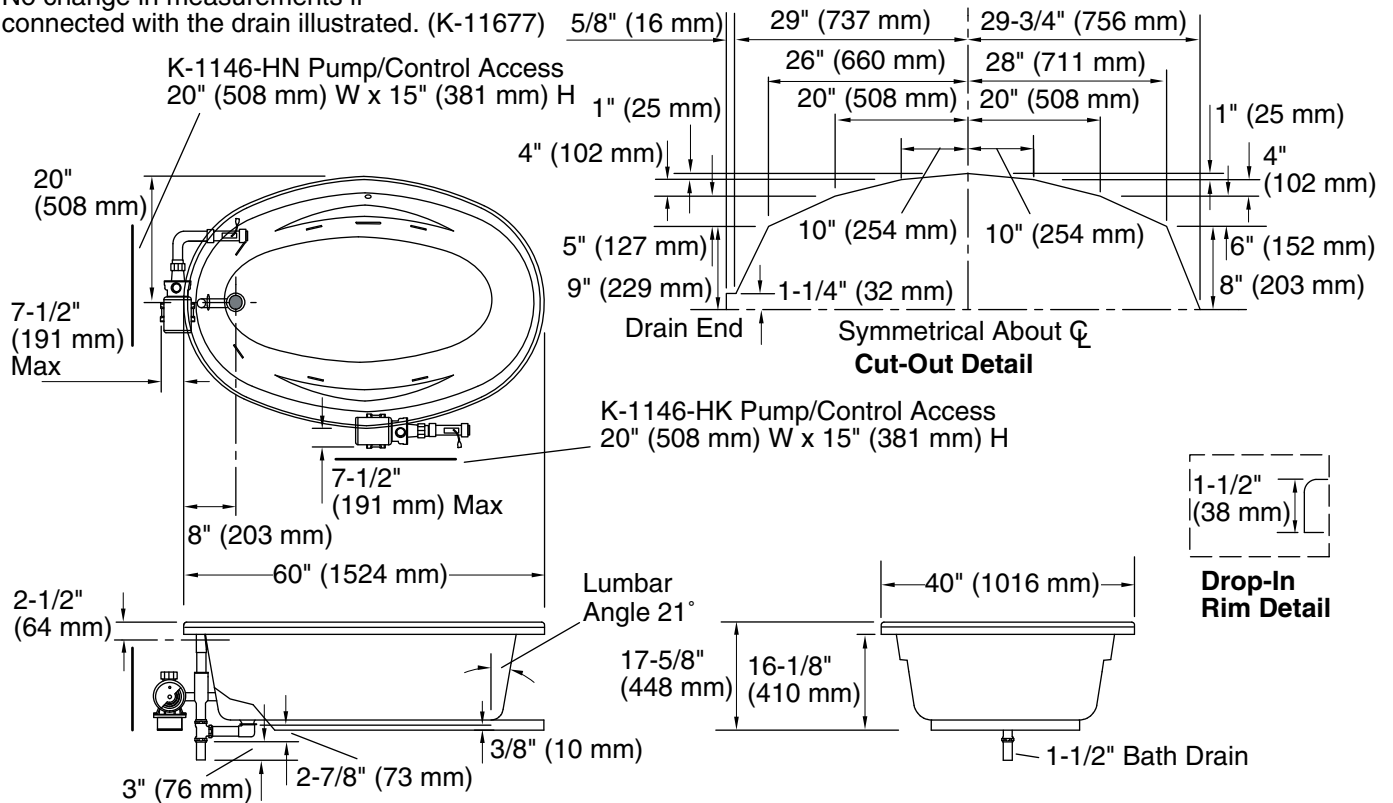

Product Diagram