

Remote control manual

Basic operation instructions:

1. Code alignment: The remote control can only be used after code alignment operation with the driver. The method is as follows: After connecting the driver to the load lamp (light source) and the power supply, switch on the power supply. At the moment of switching on the power supply (see Press (ON) within 3 seconds after the light/light source is on. When you see that the light (light source) will "flash three times slowly", that is, the code and grouping is successful.
2. Clear the code, the method is as follows: select the lamp that needs to clear the code, cut off the power, reconnect the power, after connecting the power light (Within 3 seconds), press the main open button five times, that is, the lamp/light source will "flash six times", to confirm the success of code clearing.

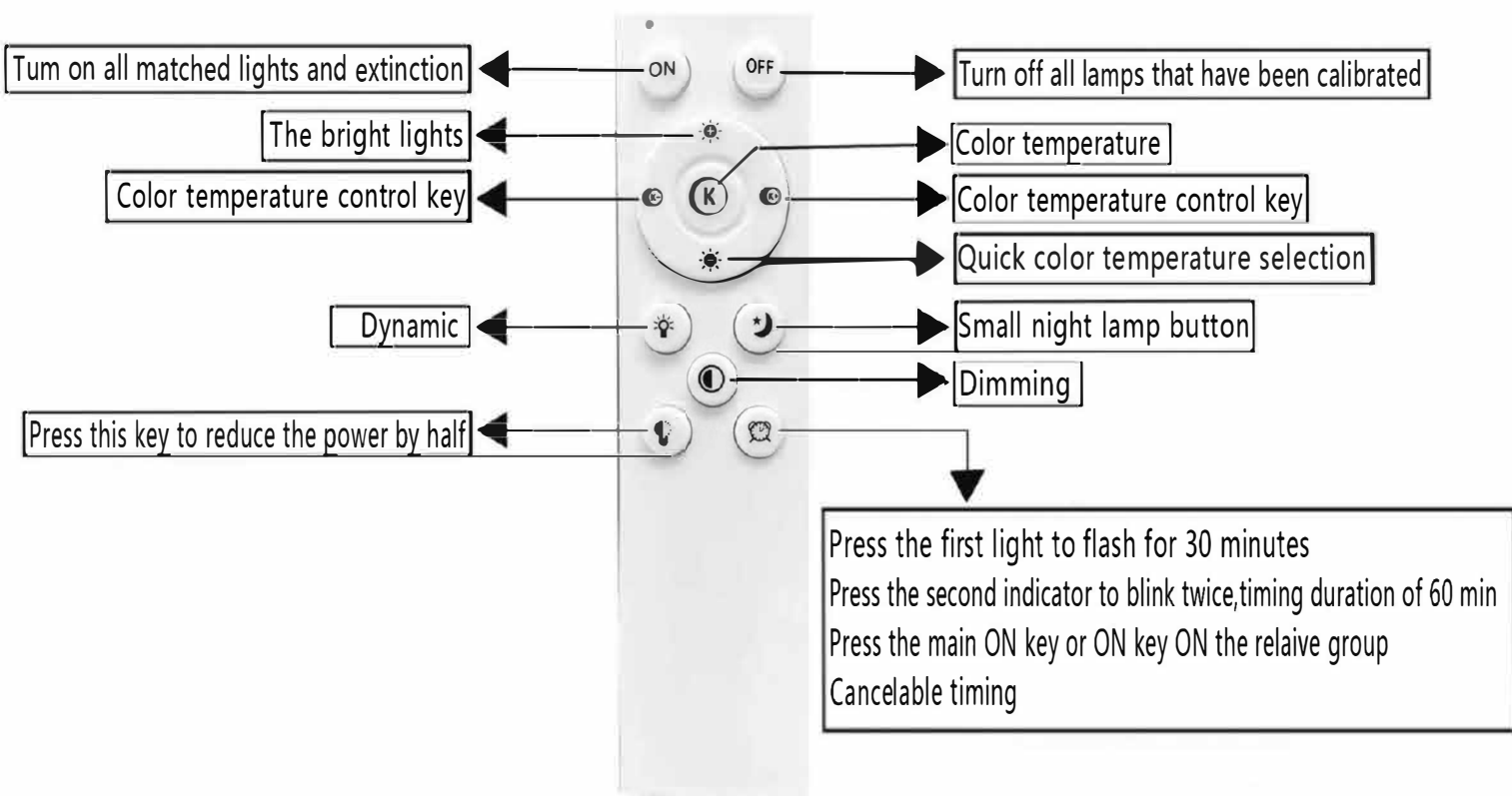

Manual Book

Installation or Assemble Instructions



WARNING: Be sure the electricity to the wires you are working on is shut off ; Either the fuse is removed or the circuit breaker is turned off. Turning the power off using the light switch is not sufficient to prevent electrical shock.

NOTE 1. The important safeguards and the instructions appearing in this manual are not meant to cover all possible conditions or situations the may occur. It must be understood that the common sense,caution and care are factors which cannot be built into any product. These factors must be supplied by the person(s) installing this unit.

NOTE 2. Before installing, you need to check with your house builder or the installer to make sure that your ceiling can support the weight of the chandelier.

NOTE 3. The chandelier must be installed by a licensed, bonded and insured electrician to do the electrical part of the installation

NOTE 4. The outlet box and bracket support structure must be securely mounted and capable of reliably supporting more than 10lb(5KG) - 180lb(80KG)

NOTE 5. The Chandelier must be mounted with a minimum of 7 ft. (2m) clearance from the ceiling edge of the to the floor.

NOTE 6. The chandelier has its own dimmer and cannot be used together with your own dimmer (to avoid short circuit).

NOTE 7. After the base is installed and electric wires are connected, hanging the crystal strings should be straight forward, arrange crystal strings from the inside to the outside . It does take some time and patience, but it is totally doable by yourself. Or you can hire a handy man to do it for you whose hourly rate will be much lower than a professionally electrician.

1.The tools you need

Ladder, pliers, wire strippers, screwdrivers, power drill(optional), a drill bit(optional)

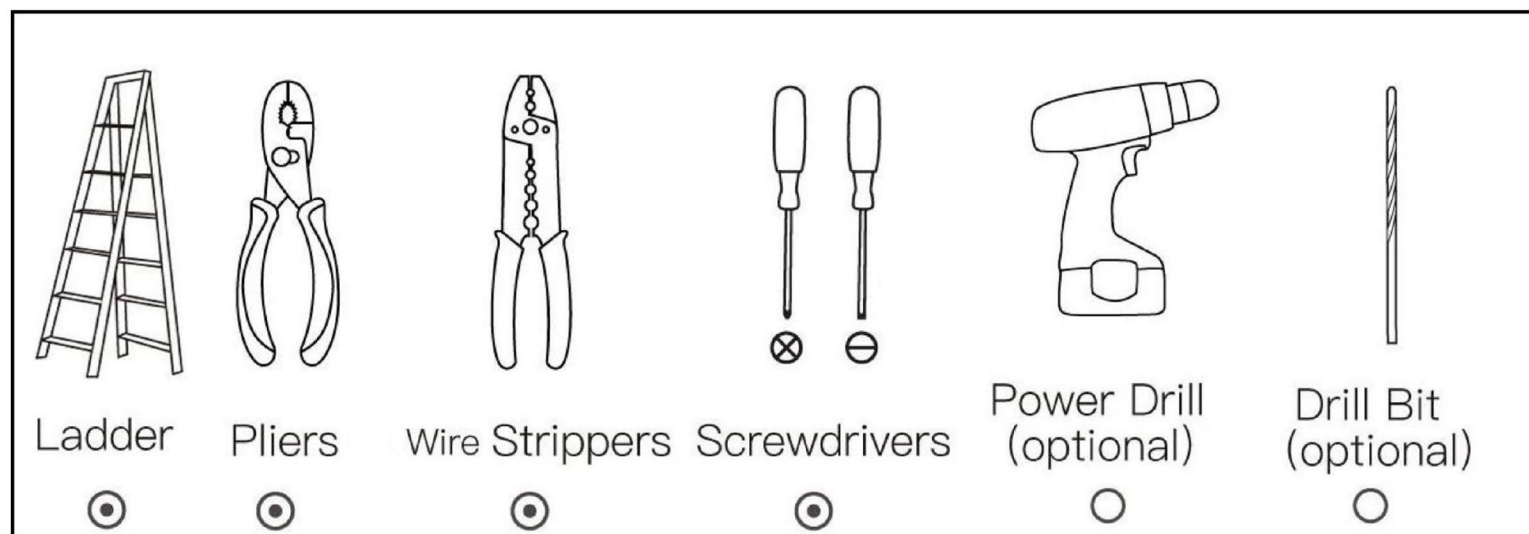

Tips: If mounting to a support structure, you will also need the other option tools.

2.Turn off the power

Turn off power at the circuit box to avoid possibleelectric shock.

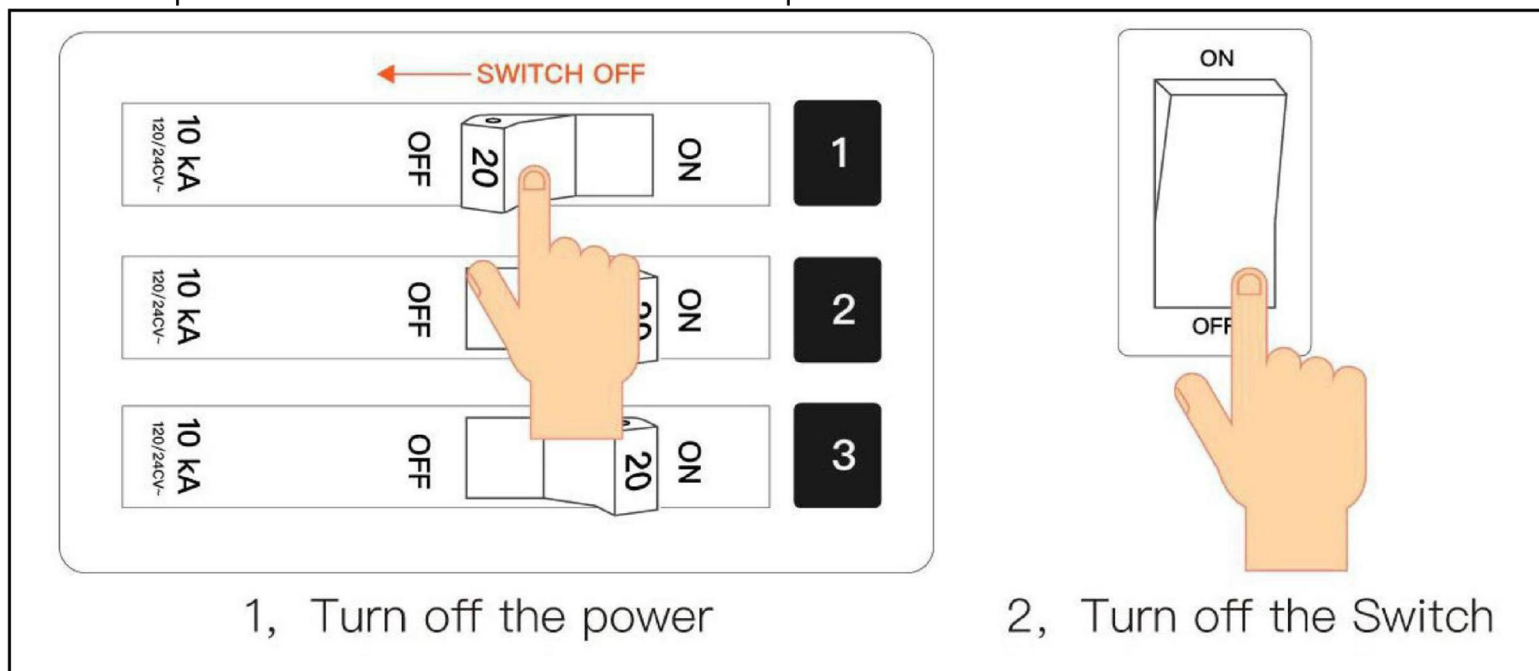

Tips: To ensure safety, you can test with a measuring pen, or you can turn on the light switch to make sure the power is off.

STEP 3: Install the Mounting Bracket

- ① Remove the mounting bracket from the ceiling plate of the chandeliers.
- ② Place mounting bracket on ceiling and mark out the points where you need to drill holes.

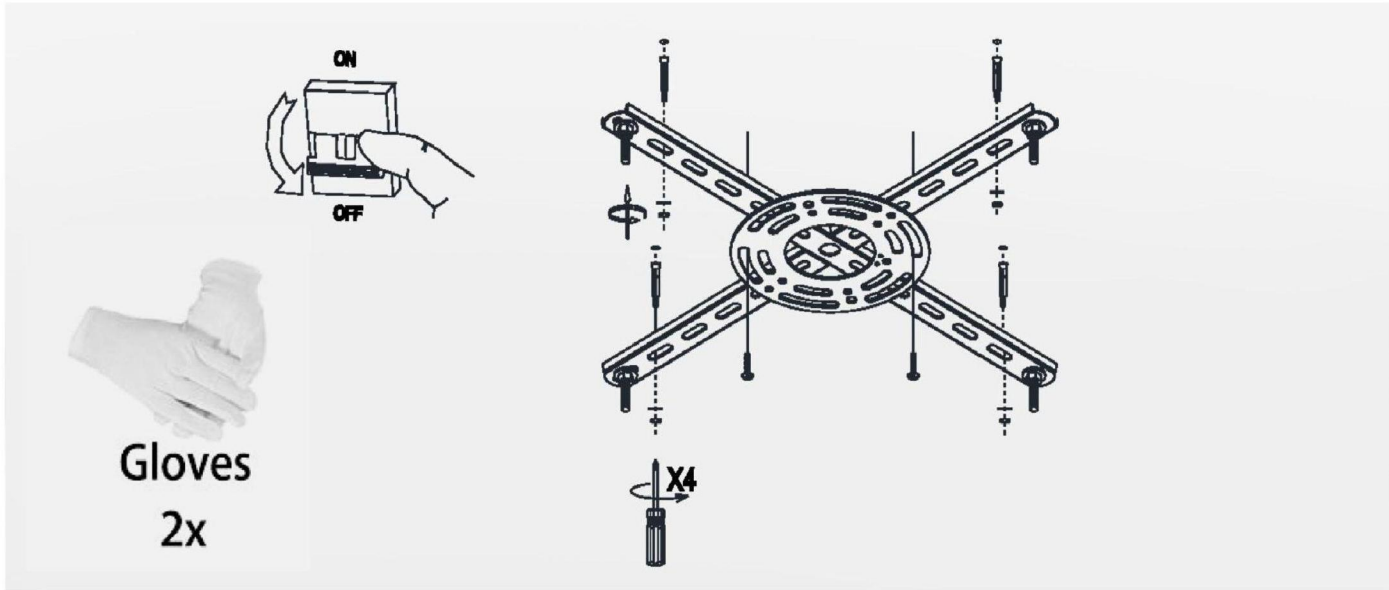

Tips: To ensure safety, you can test with a measuring pen, or you can turn on the light switch to make sure the power is off.

STEP 4: Install auxiliary ropes and connect wires

After the support is installed on the wall, please hook the end of the auxiliary rope to the lamp body for wiring procedure.

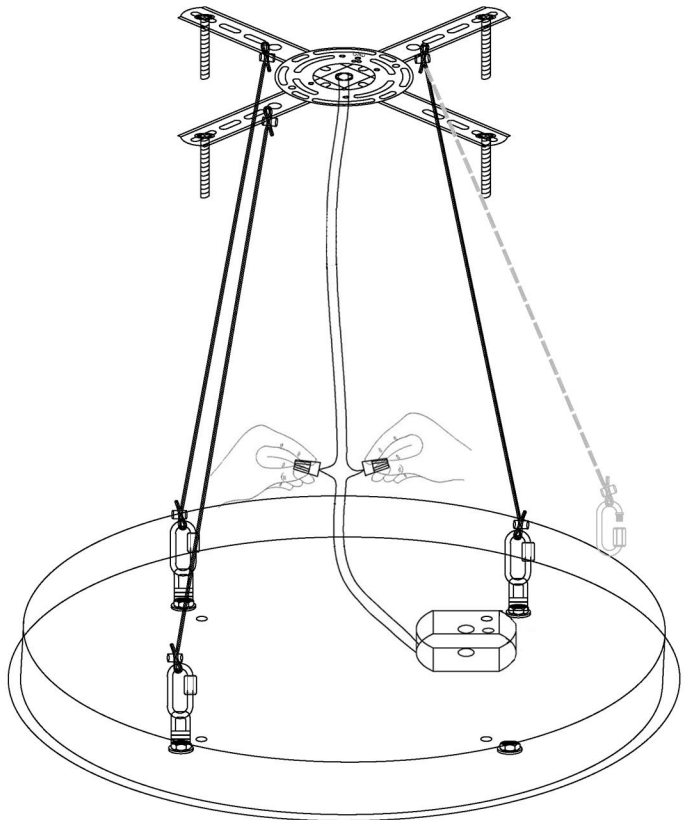

STEP 5: Installation steps

1. The motor "green" wire to the "Ground wire" wire from outside Outlet Box.
2. The motor "white" wire to the "AC IN <N>" wire from outside Outlet Box.
3. The motor "black" wire to the AC IN <L>" wire from outside Outlet B
4. Finally, put the connected wires in the hanger.

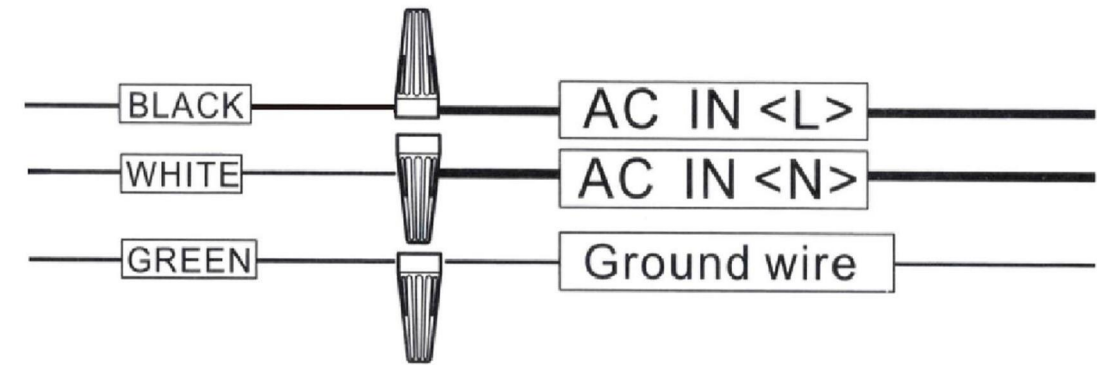

STEP 6: Connect wires and install the canopy.

Most chandeliers have black and white lines. Connect the black/brown wire to the live wire, the white/blue wire to the neutral wire, and the yellow/green wires to the ground wire (optional). Attach the stripped end of the black power cord with the stripped end of the black/brown wire of the chandelier and screw them together with a wire nut. Do the same for the white/blue wire with the white power cord.

- ① Connect the wires based on the instruction above and attach canopy to the mounting bracket with bolt cap (provided).

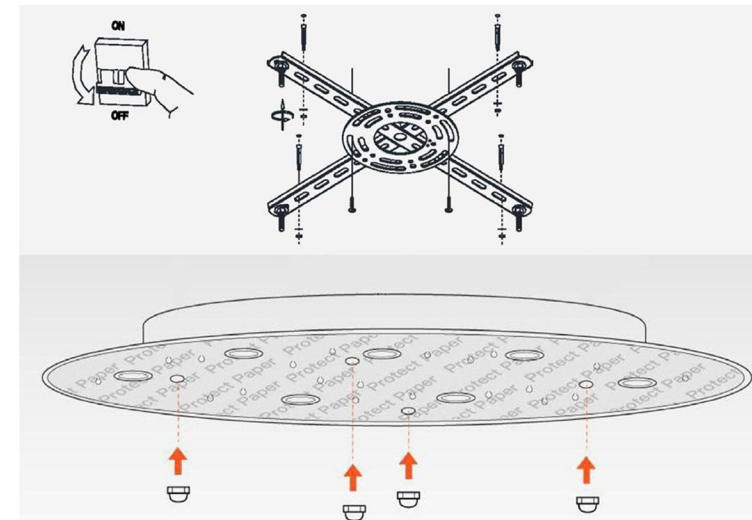

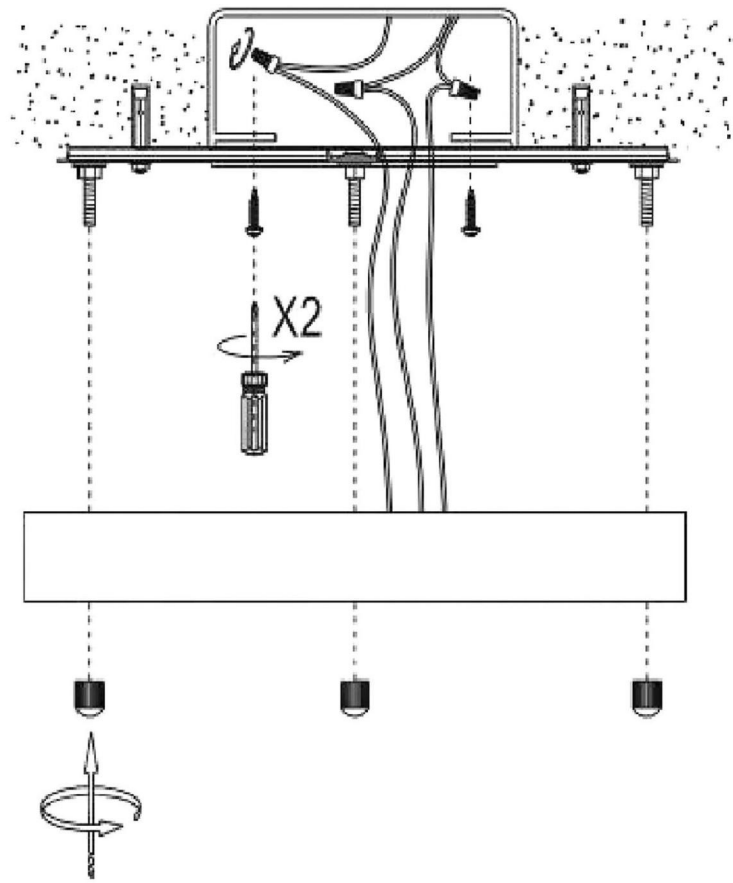

STEP 7: Check

Congratulations, you have completed the installation for your chandelier! One last thing to do is to check it from a distant just to make sure that the crystal chandelier is leveled and at proper height. Make additional small adjustment as needed. After ensuring safety, you can turn on your house's power switch and the light switch for the crystal chandelier. Now you can enjoy the beautiful chandelier that you just installed for your home.

How to adjust hanging wire



Cable locker

Shorten wire ↑

1. **Shorten** the hanging wire:
no need to use wrench, just push the wire upwards.

Cable locker

Extend wire ↓

2. **Extend** the hanging wire:
need to use wrench to press up on the cable locker and pull down the wire.

Tips: You can also use your fingers or other tools instead of wrench.

Wrench

STEP 7: Connect wires and install the canopy.

② Remove protective film on the canopy and chandelier base.

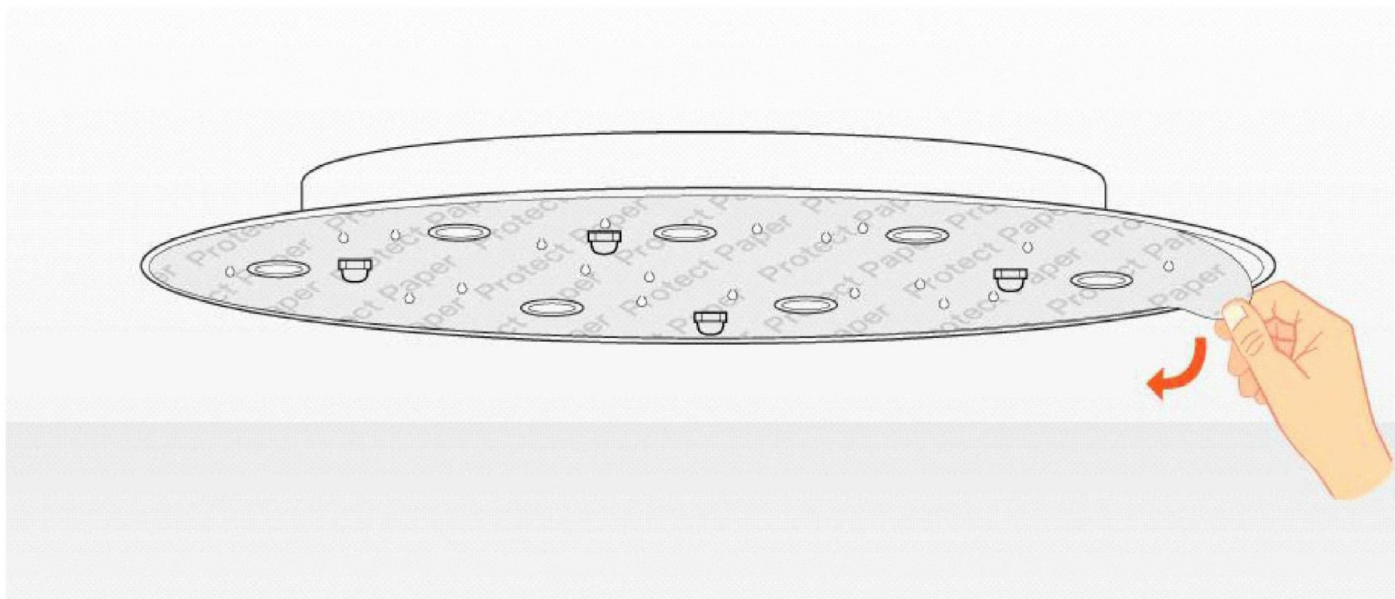

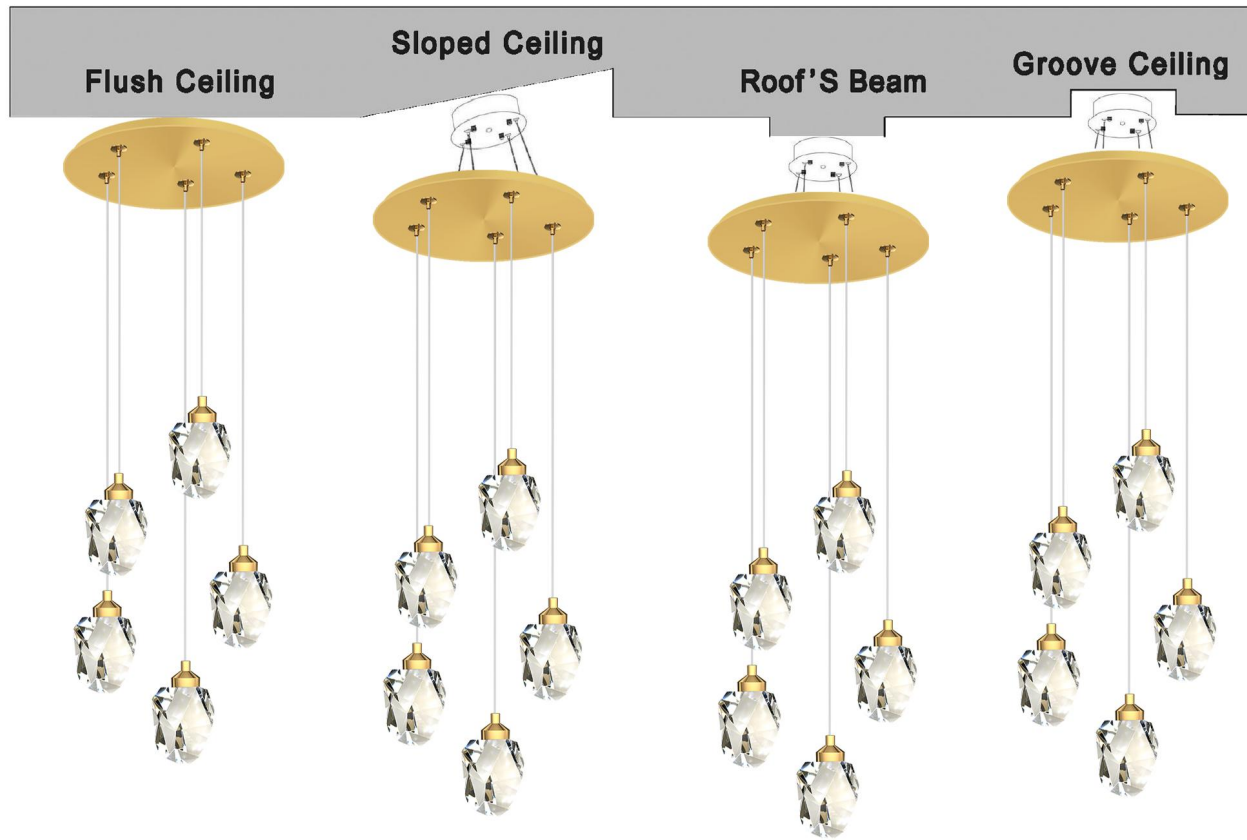

Schematic diagram of the small ceiling link:

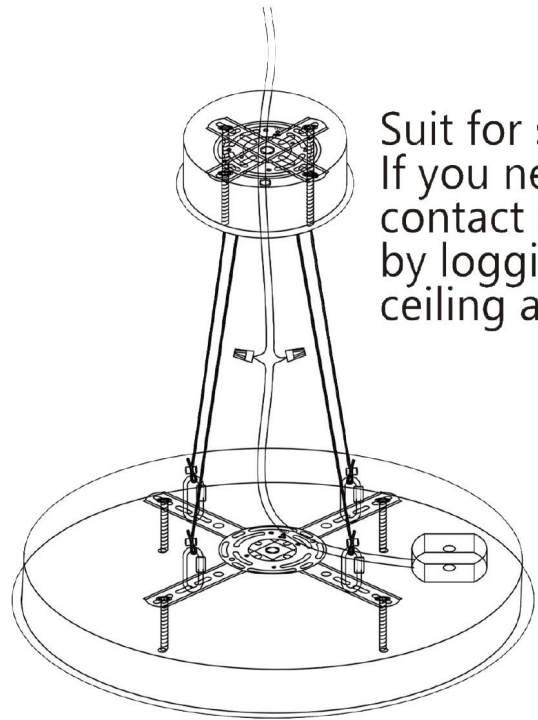

Suit for sloped ceiling, recessed ceiling, convex ceiling, If you need the reissue small ceiling accessories, please contact us. We will arrange for you. You can also find it by logging into the store and searching for the tilting ceiling adapter.

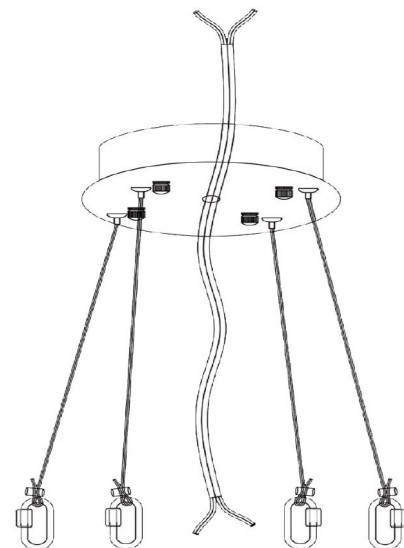

Our company warrants its chandelier light unit for Five year from the date of purchase. The warranty includes all parts provided, we provide the replacements for any missing or damaged parts. the unit is installed properly by a licensed electrician. Labor charges will be the responsibility of the purchaser. If the unit does not operate properly, the purchaser must contact us to determine if the unit was installed properly. Any alteration or by-passing of the electrical or mechanical system of exceeding the wattage maximum (as indicated on the chandelier) will void the warranty and can result in an electrical hazard.

If there are any problems about the item, please contact with us via order page.

Regular Switch



Dimmer Switch



Avoid using all dimmer wall controls