

BED FRAME

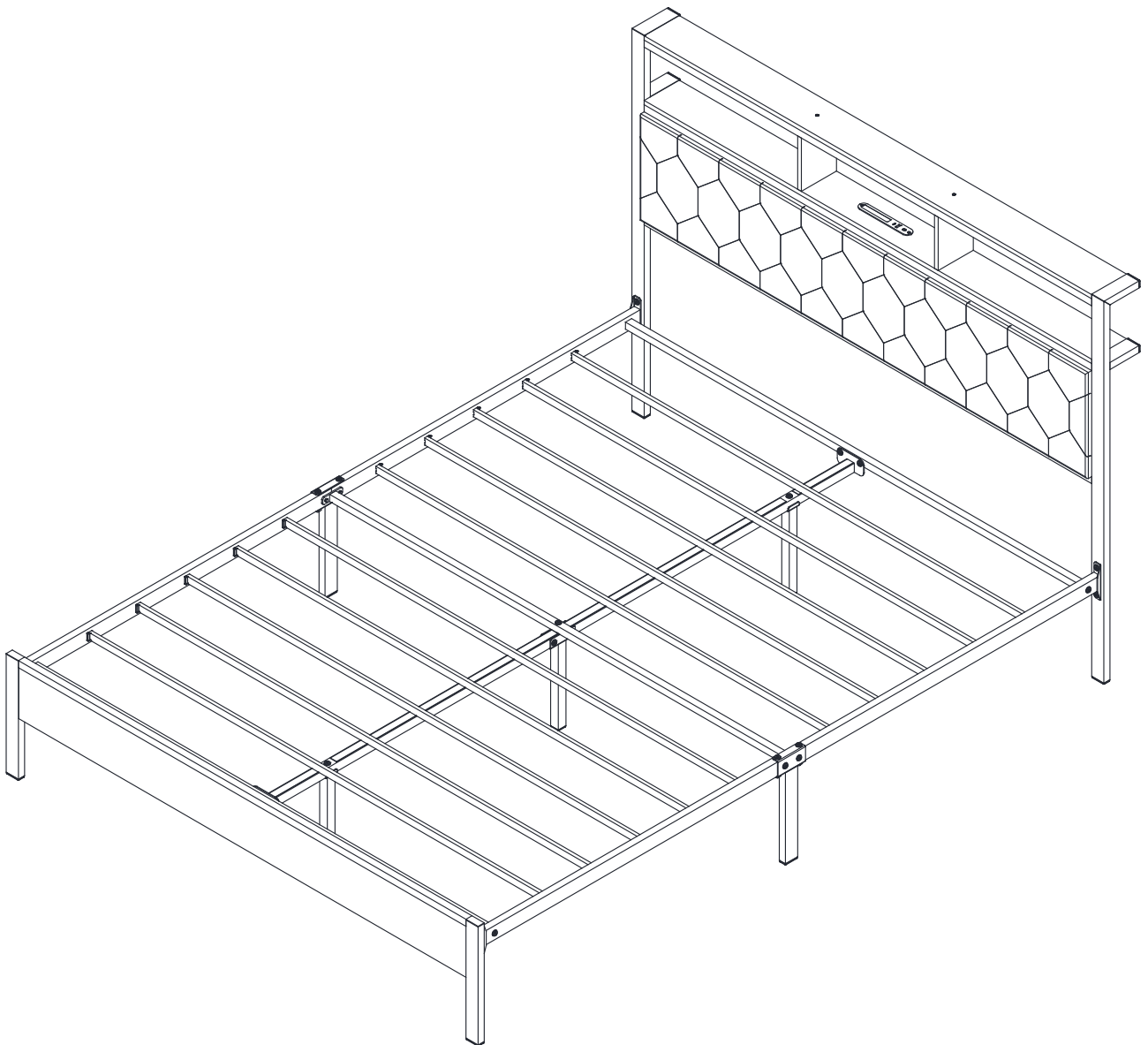

Thank you for choosing our products, please assemble and use it following the instructions.

Assembly Instruction

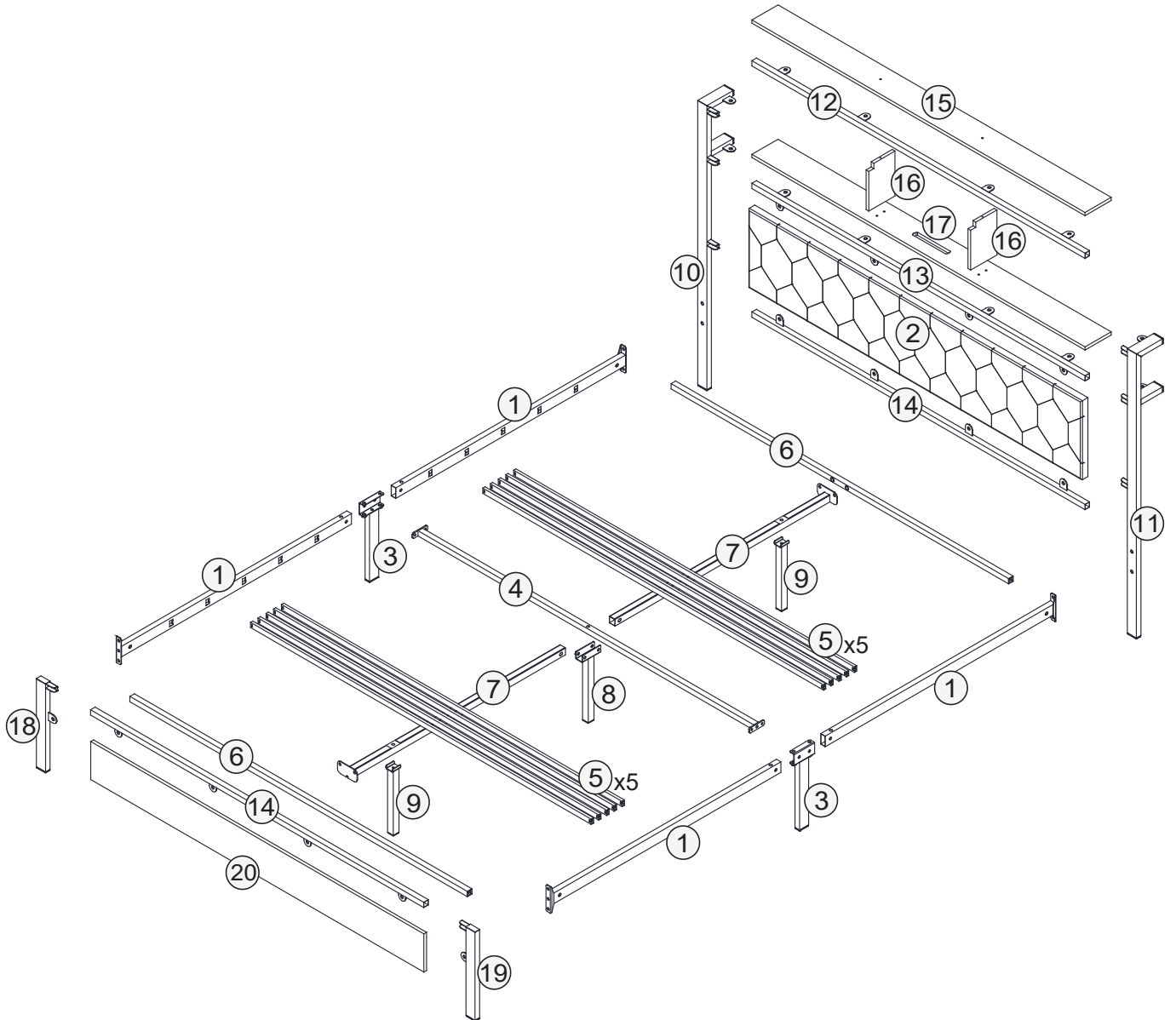

Important Note

HARDWARE NOTE :

1. Two or more people are required for assembly
2. Do not screw on the bolts too tight unless the installation is done. Make sure all bolts are tightly screwed before you use it.

Components

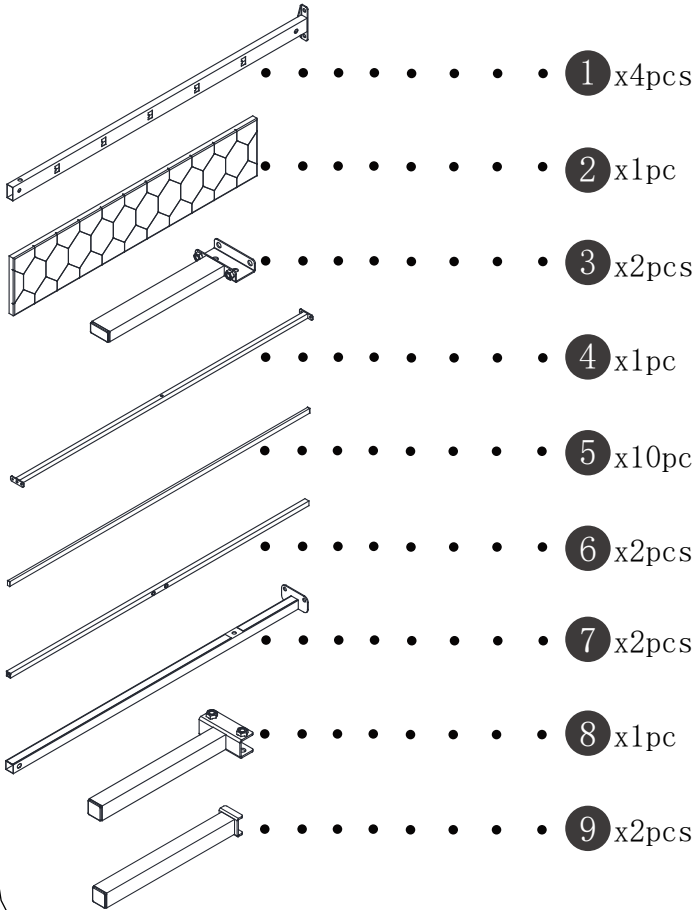

1 x4pcs

2 x1pc

3 x2pcs

4 x1pc

5 x10pcs

6 x2pcs

7 x2pcs

8 x1pc

9 x2pcs

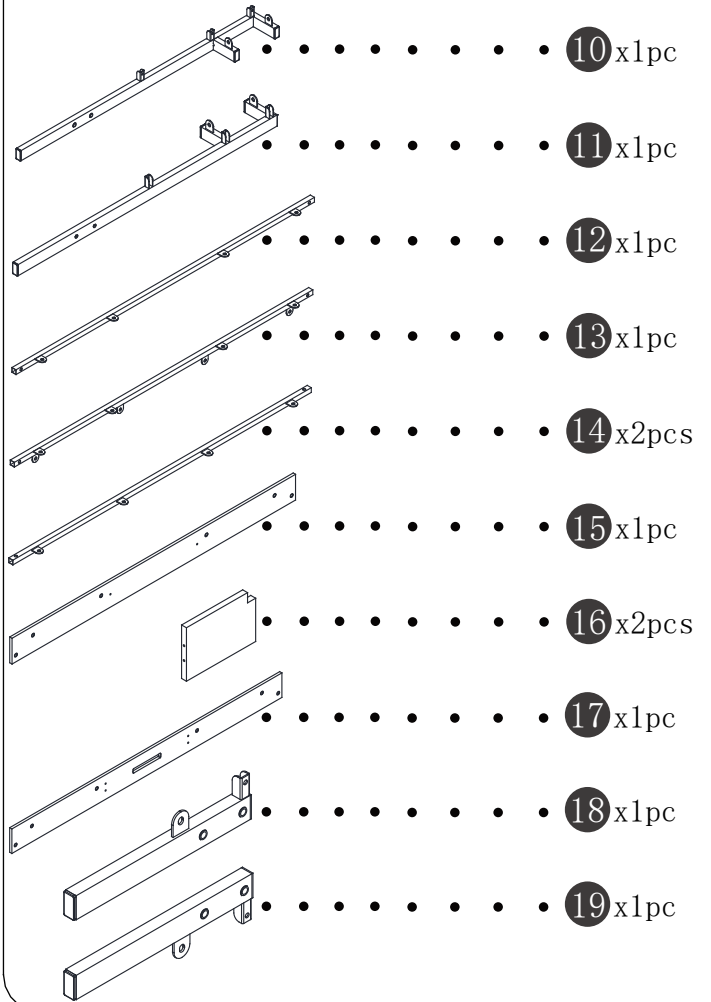

10 x1pc

11 x1pc

12 x1pc

13 x1pc

14 x2pcs

15 x1pc

16 x2pcs

17 x1pc

18 x1pc

19 x1pc

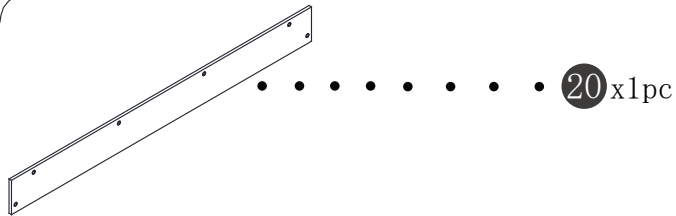

20 x1pc

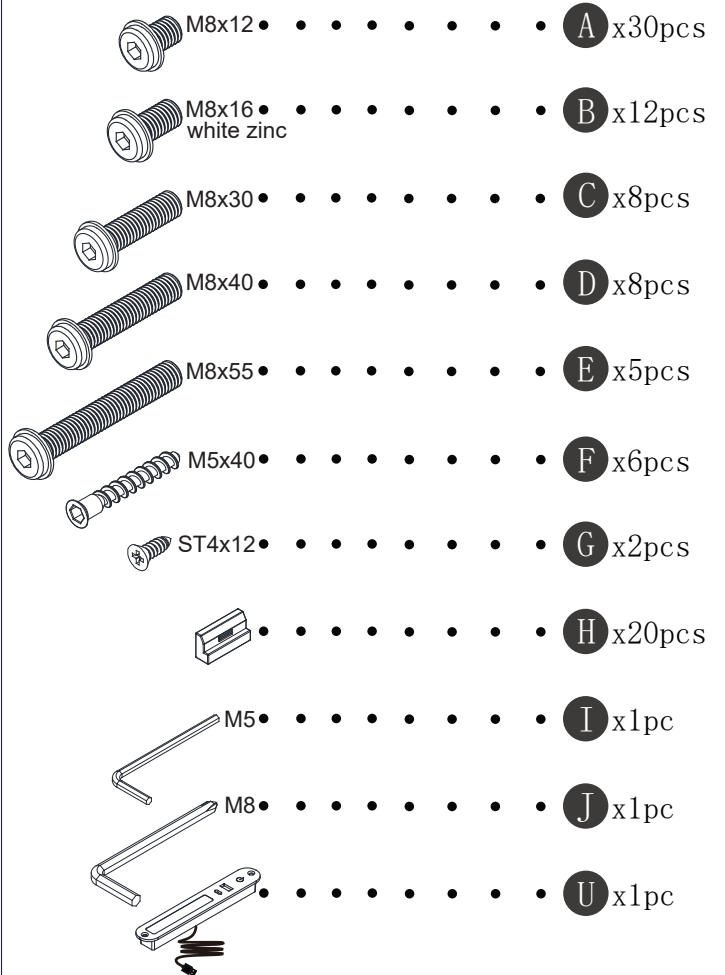

A x30pcs

B x12pcs

C x8pcs

D x8pcs

E x5pcs

F x6pcs

G x2pcs

H x20pcs

I x1pc

J x1pc

U x1pc

1

⚠ Do not fully tighten the screws yet.

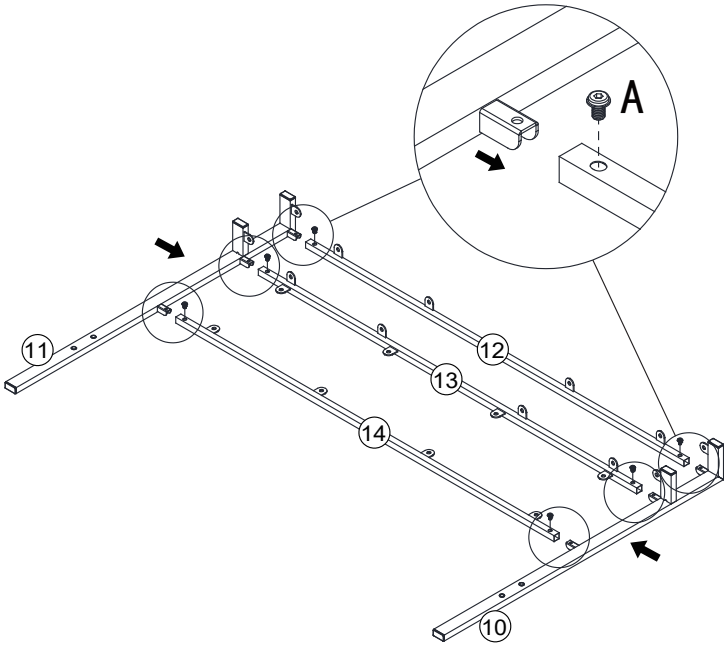

A		6pcs
	M8x12	

2

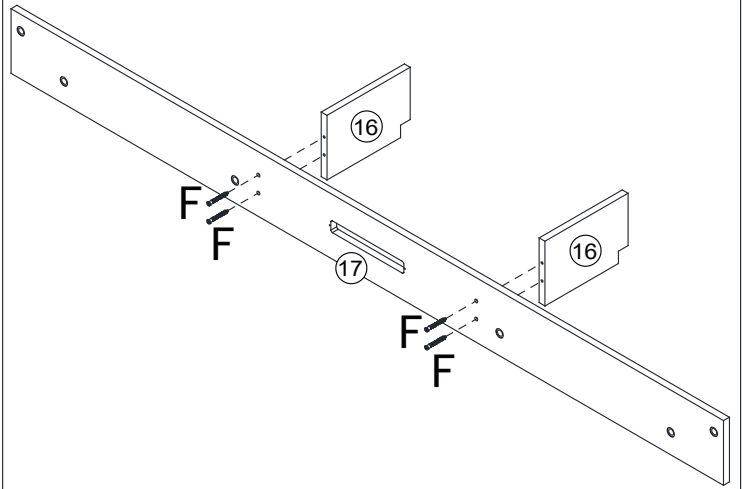

F		4pcs
	M5x40	

3

Pull component 12 outward and then insert Component 17.

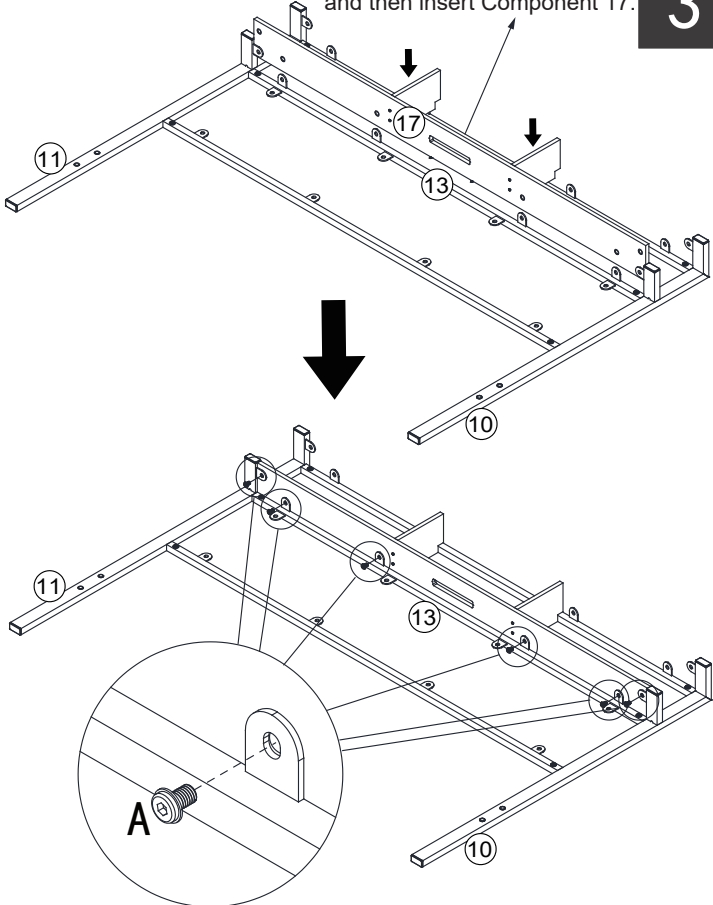

A		6pcs
	M8x12	

4

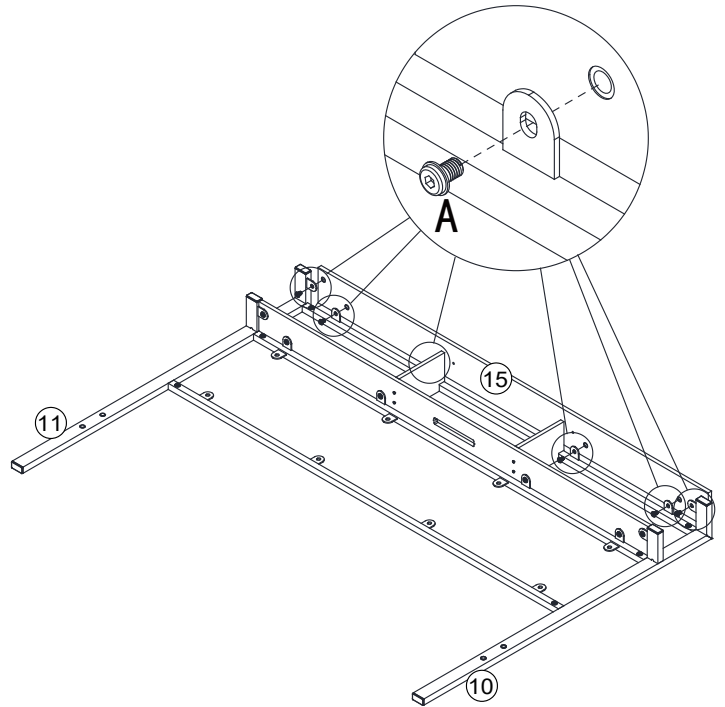

A		6pcs
	M8x12	

5

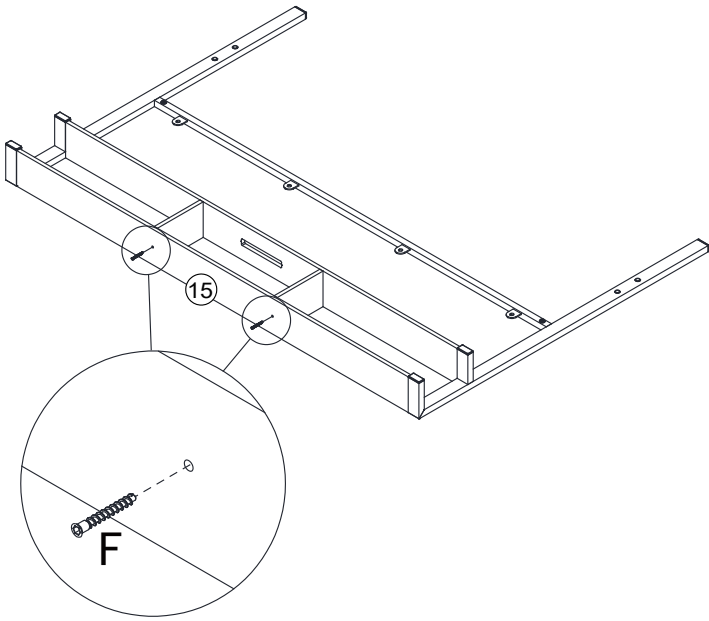

F		2pcs
	M5x40	

6

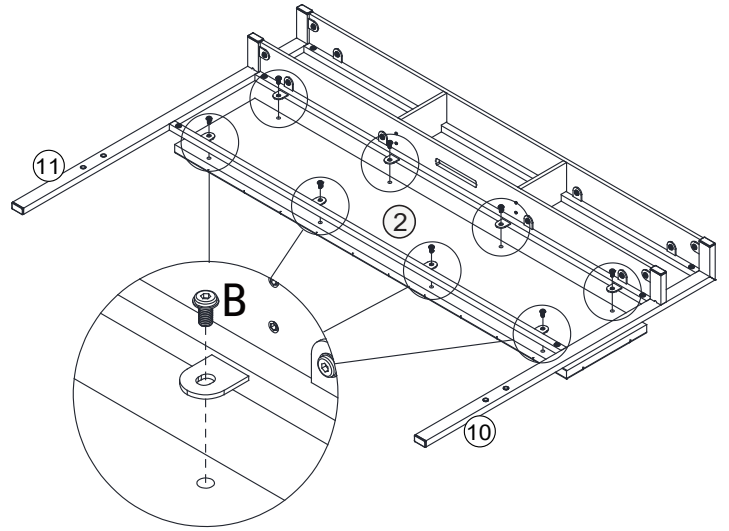



 Fully tighten all the screws.

B		8pcs	white zinc
	M8x16		

7

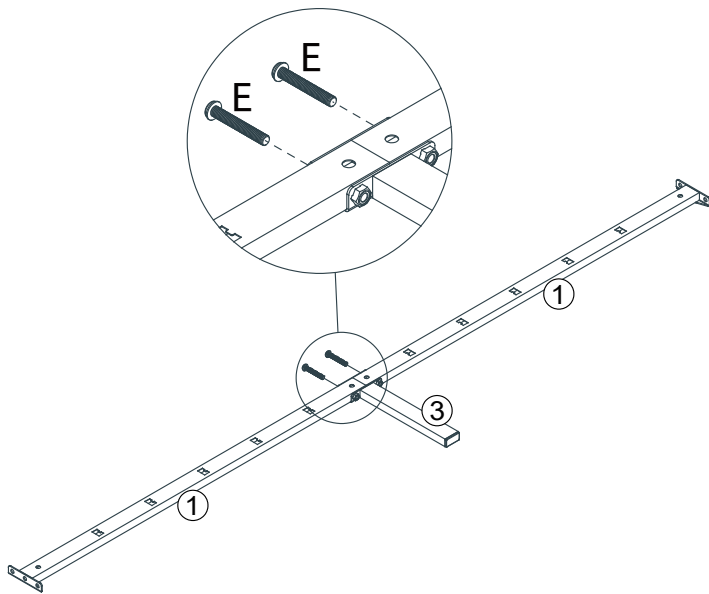
x2



E		4pcs
	M8x55	

8

 Do not fully tighten the screws yet.

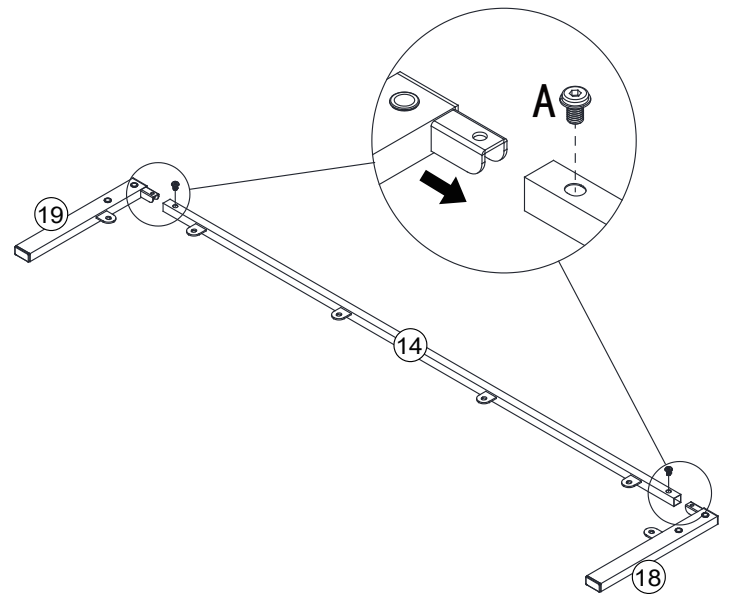

A		2pcs
	M8x12	

9

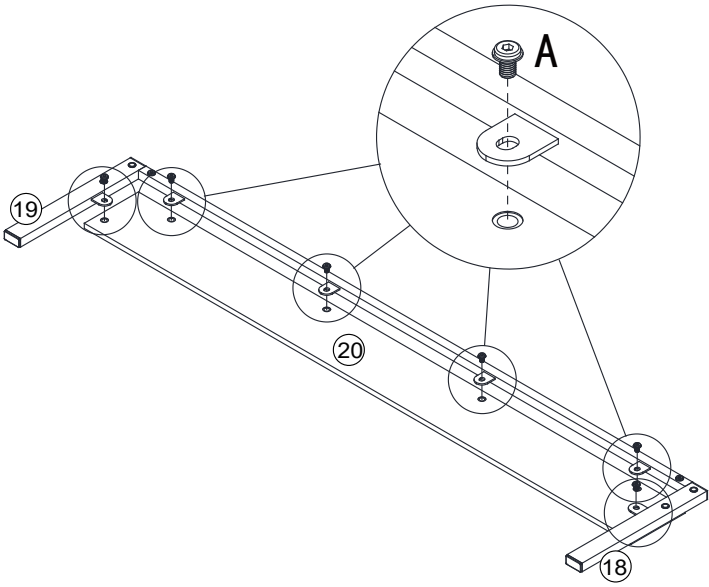

! Fully tighten all the screws.

A		6pcs
M8x12		

10

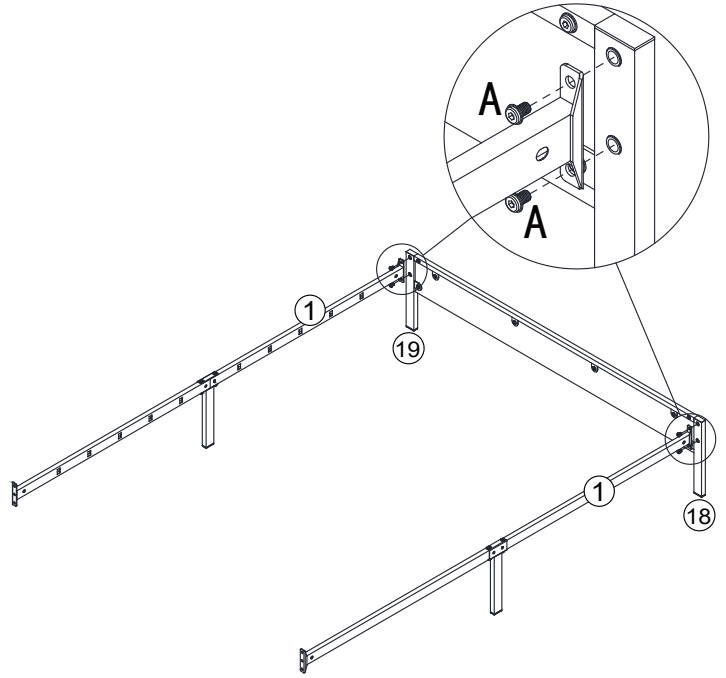

A		4pcs
M8x12		

11

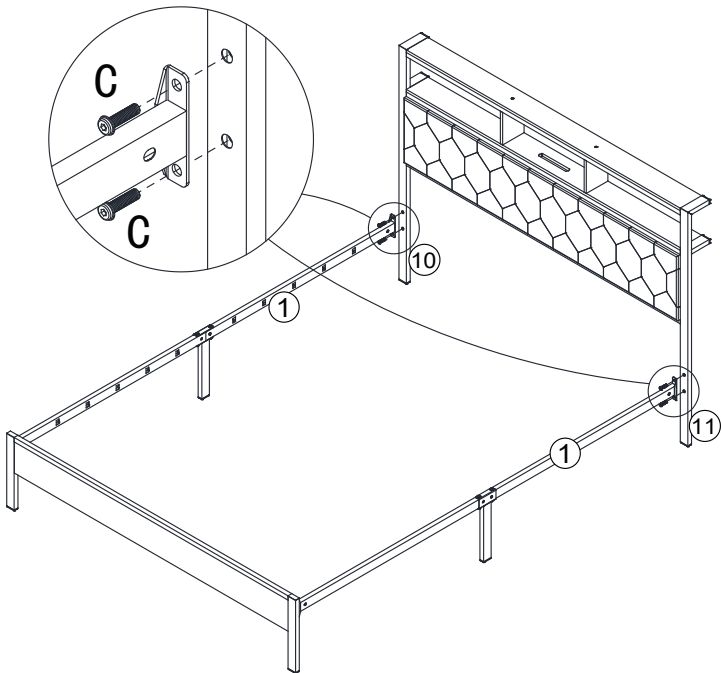

C		4pcs
M8x30		

12

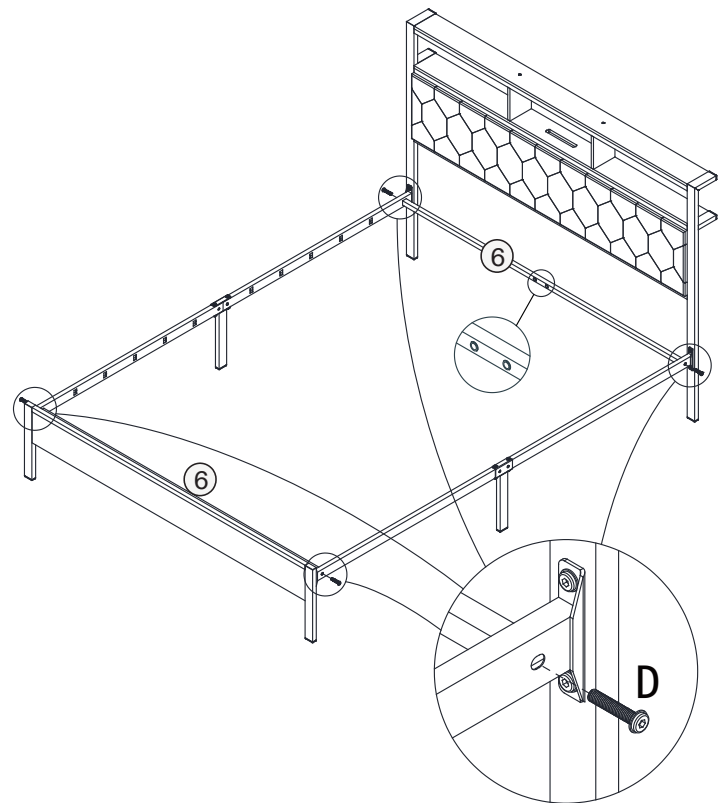

D		4pcs
M8x40		

13

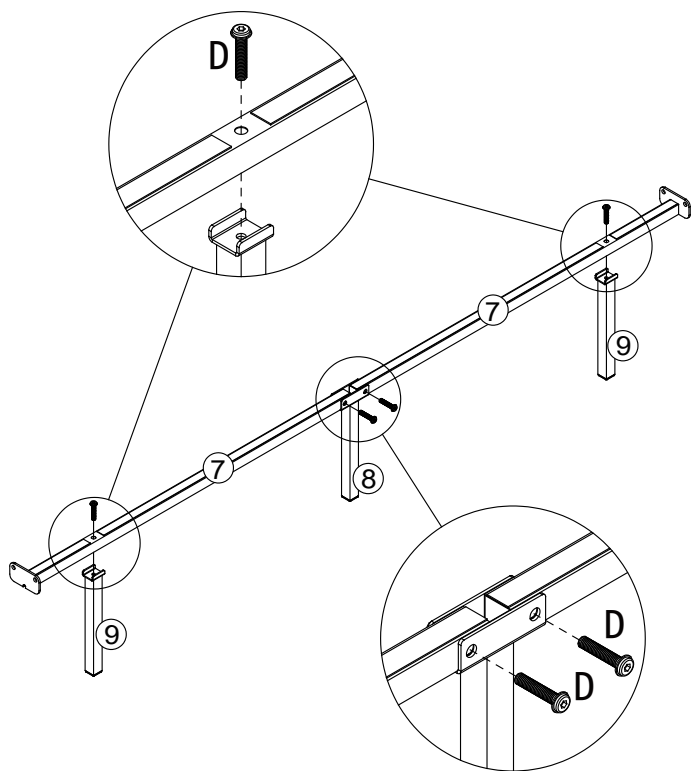

! Do not fully tighten the screws yet.

D		4pcs
	M8x40	

14

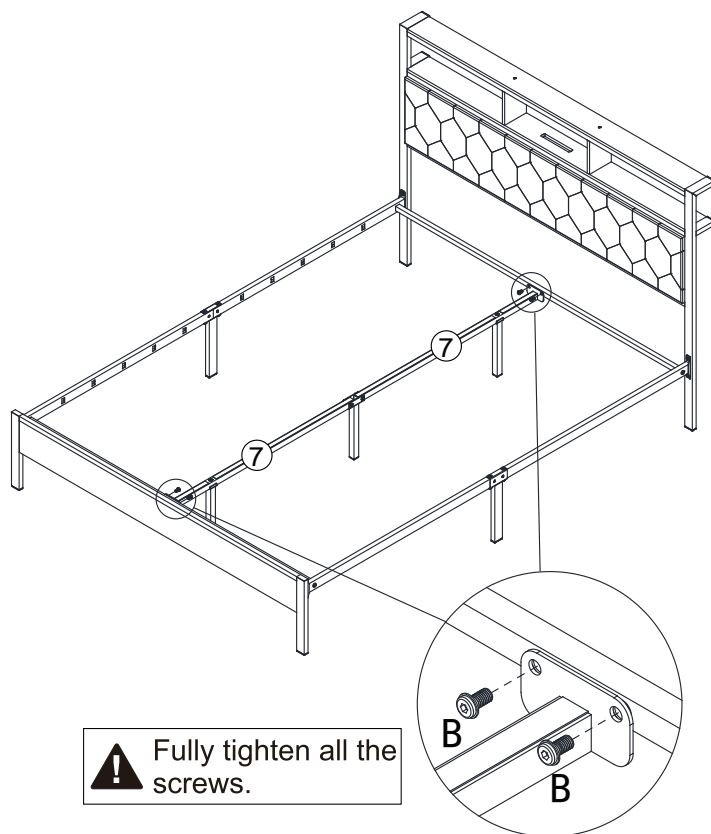



! Fully tighten all the screws.

B		4pcs	white zinc
	M8x16		

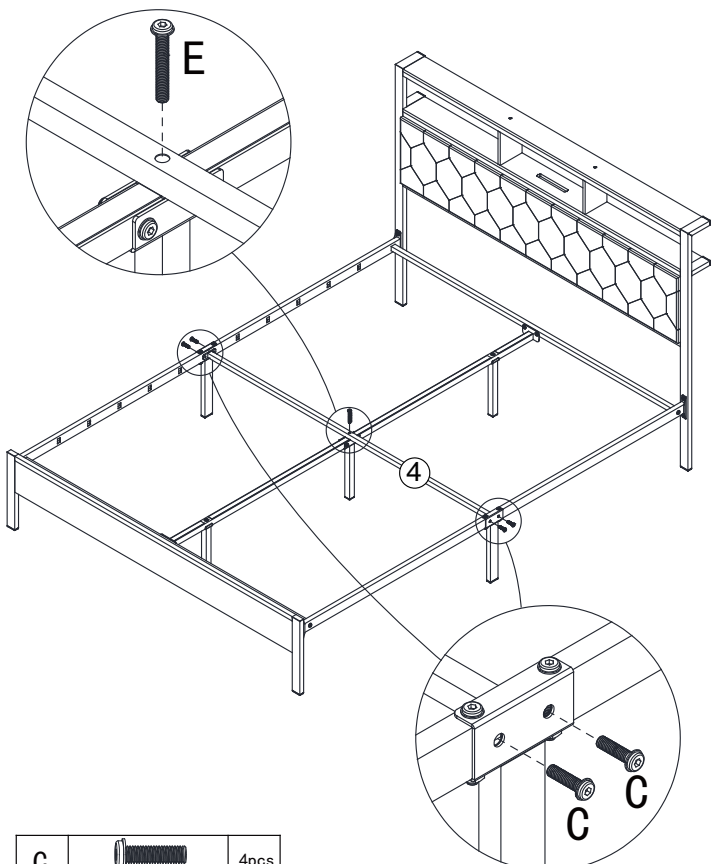
15



C		4pcs
	M8x30	
E		1pc
	M8x55	

16

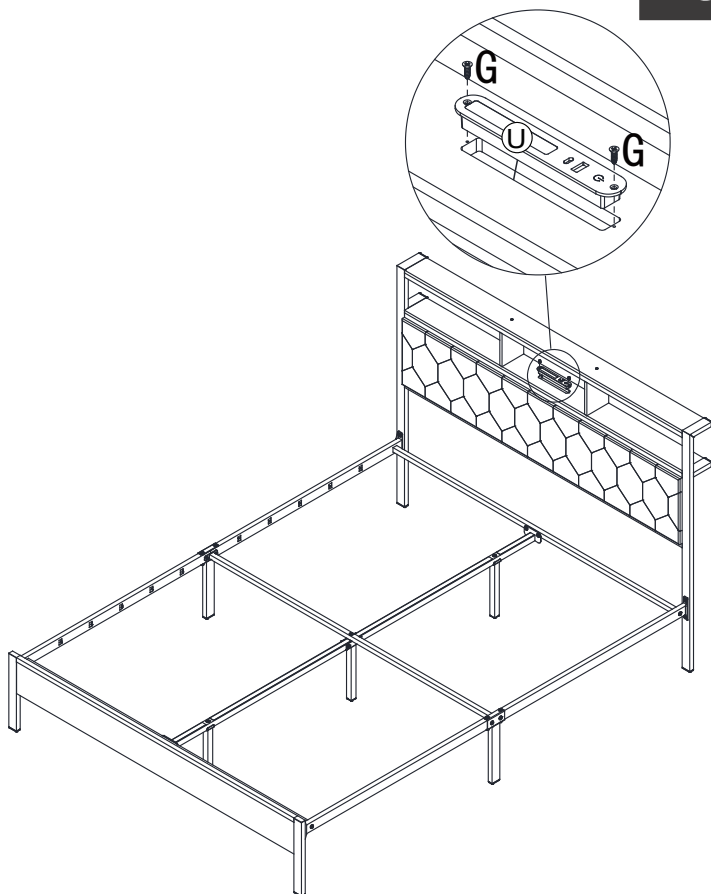

G		2pcs
	ST4x12	

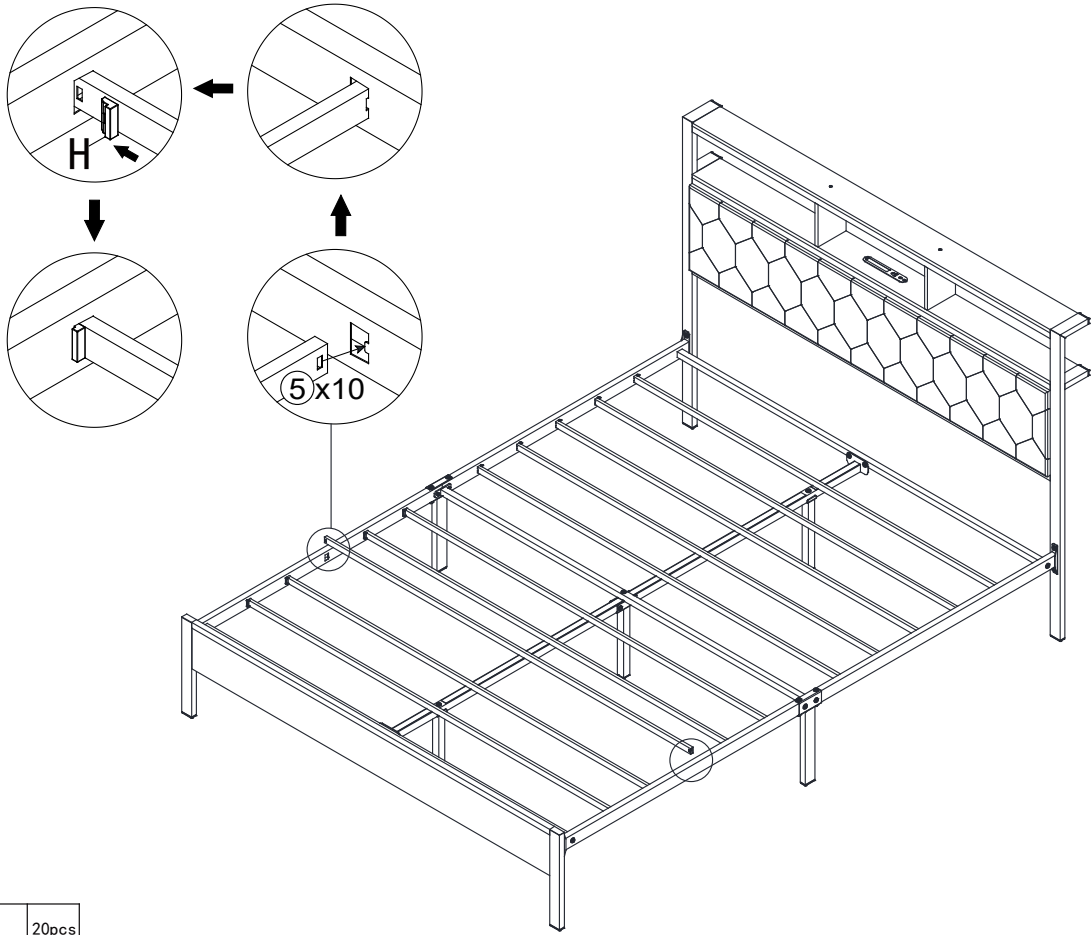

H		20pcs
---	-------------------------------------------------------------------------------------	-------

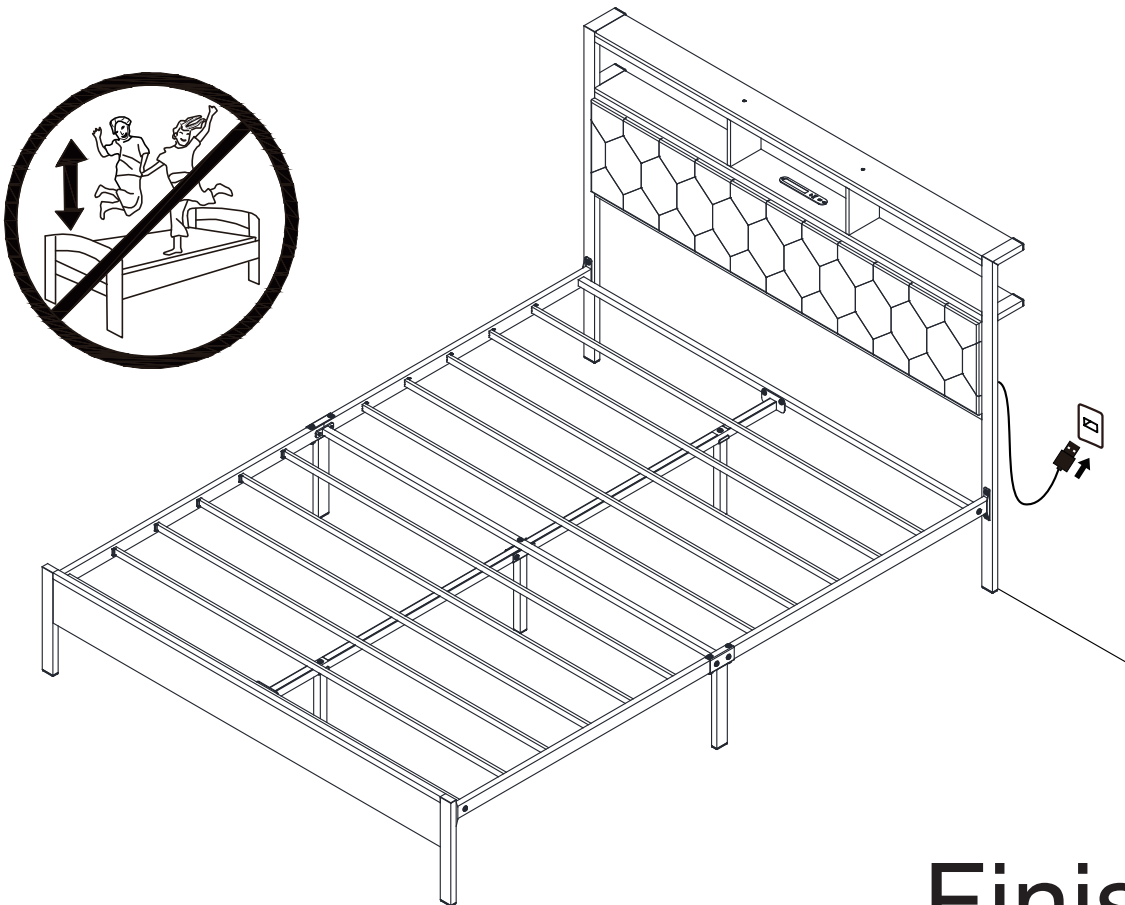

Finish