

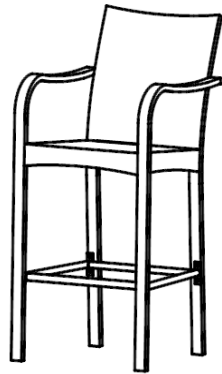



# Assembly Instructions

Caution : You should read this carefully before you proceed





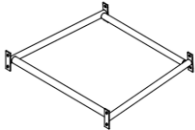
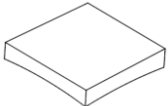

## Barstool



### Parts List

Label	Picture	Description	QTY
A		Backrest	1
B		Left Armrest	1
C		Right Armrest	1
D		Foot Rest	1
E		Seat Panel	1

# Hardware

Label	Picture	Description	QTY
①		Allen Key	1
②		Bolt (M6*65MM)	3
③		Bolt (M6*40MM)	9
④		Bolt (M6*20MM)	9
⑤		Bolt Cap	11
⑥		Washer	19

# Assembly Preparation

Before Beginning Assembly:

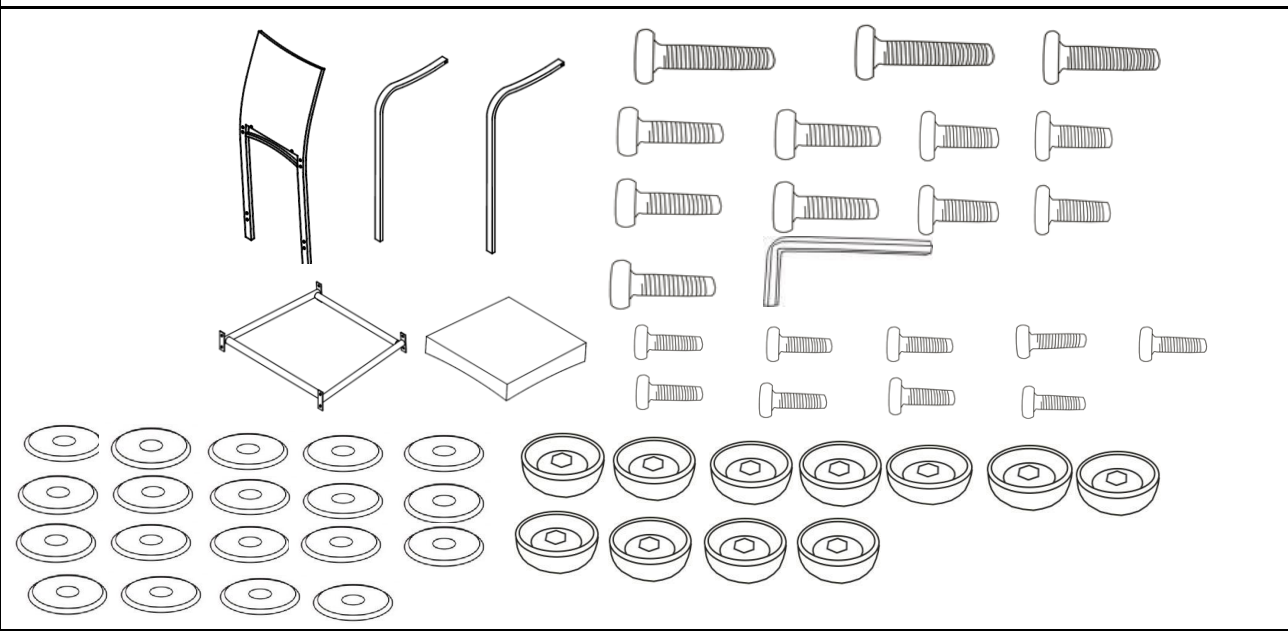

- Read instructions, cover to cover-



- Have 2 adults on hand for assembly-



- Do not assemble on flooring or carpet-



- Assemble on a clean non-marring surface (packing foam)-



- Save all packaging until finished-

# Assembly Steps

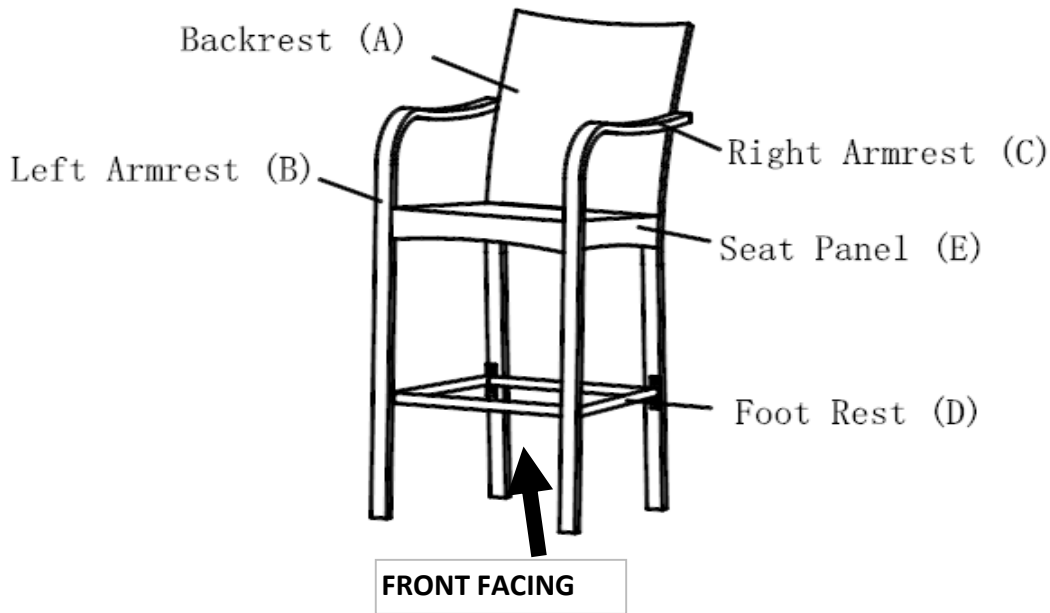

This Barstool has multiple parts and may require up to 45minutes to assemble. To give you an overview of the Barstool parts, the above picture is to help you put the various parts into perspective. Please read through the instructions below to familiarise yourself with the parts and steps before assembly.

## Step 1

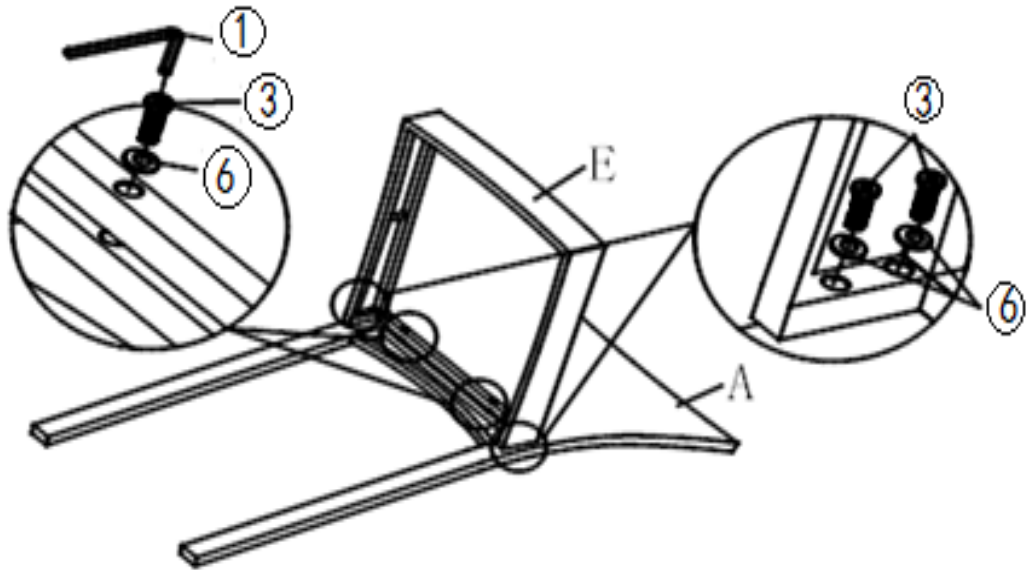

Place the Backrest (A) and the Seat Panel (E) on a clean, flat surface. Use bolts (3) and washers (6) to connect the Seat Panel (E) to the Backrest (A). Note: Do not use the Allen Key (1) to tighten the bolts completely until all parts are assembled.

## Step 2

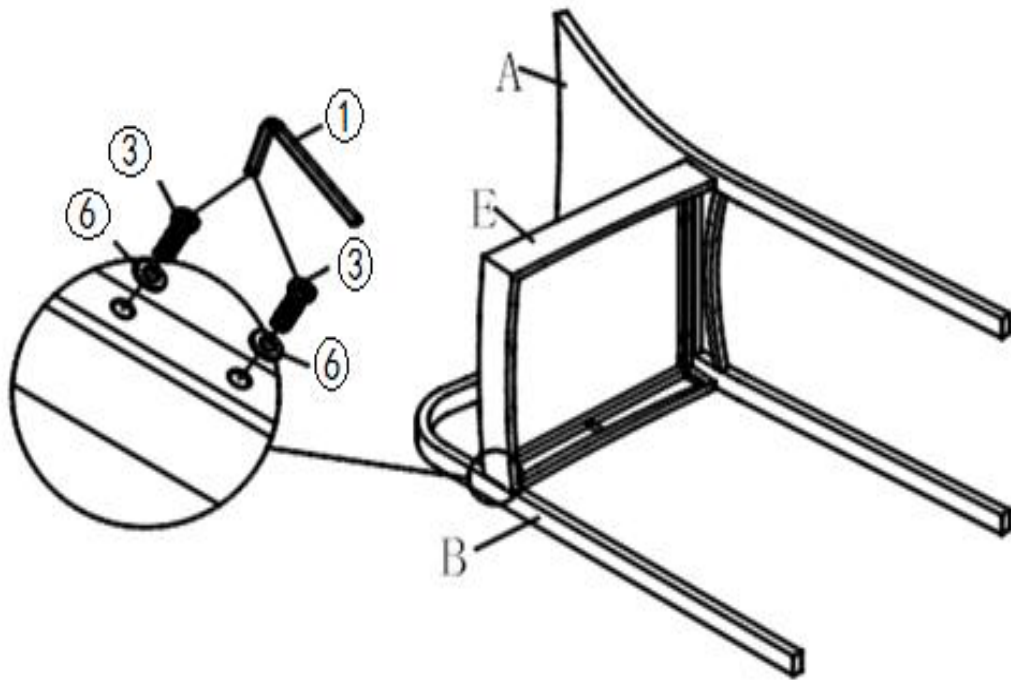

Place the Left Armrest (B) on a clean, flat surface.  
Use bolts ( 3 ) and washers ( 6 ) to connect the Left Armrest (B) to the Seat Panel (E).  
Note: Do not use the Allen Key (1) to tighten the bolts completely until all parts are assembled.

## Step 3

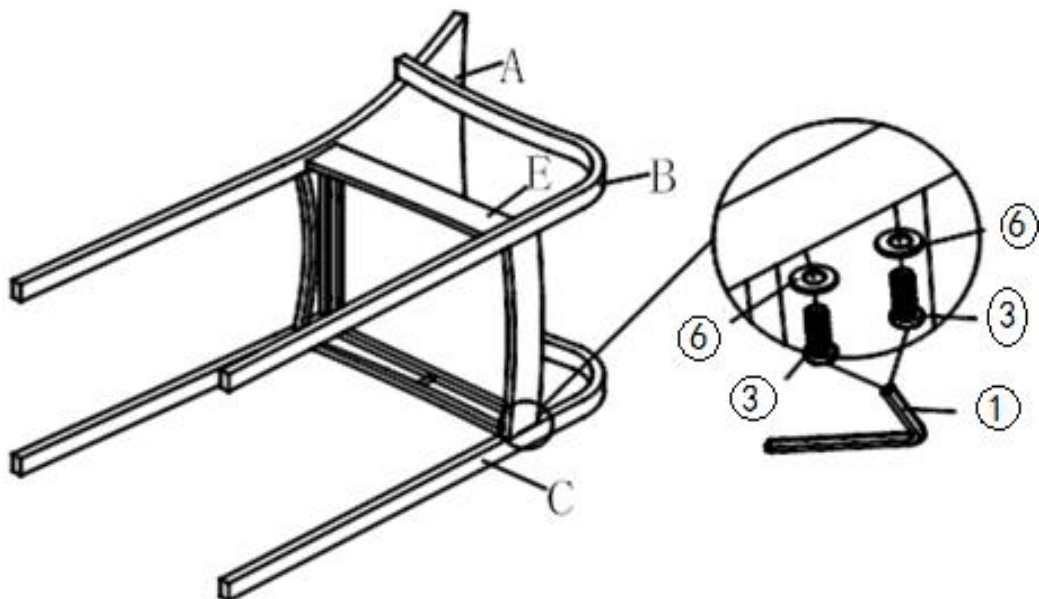

Place the Right Armrest (C) on a clean, flat surface.  
Use bolts ( 3 ) and washers ( 6 ) to connect the Right Armrest (C) to the Seat Panel (E).  
Note: Do not use the Allen Key (1) to tighten the bolts completely until all parts are assembled.

## Step 4

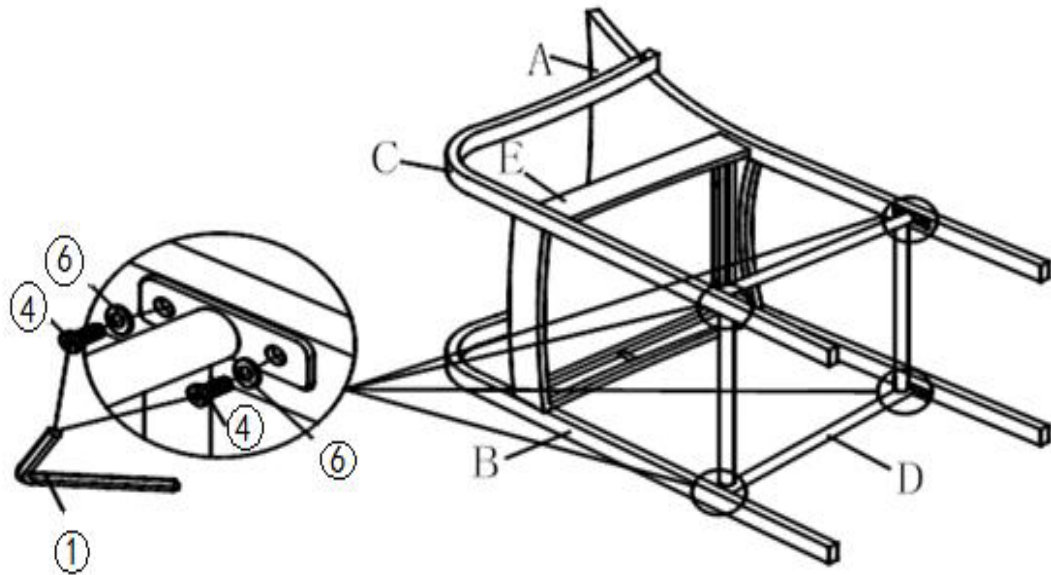

Place the Left Armrest (B) on a clean, flat surface.

Use bolts (4) and washers (6) to connect the Foot Rest (D) to the Left Armrest (B), the Right Armrest (C) and the Backrest (A).

Note: Do not use the Allen Key (1) to tighten the bolts completely until all parts are assembled.

## Step 5

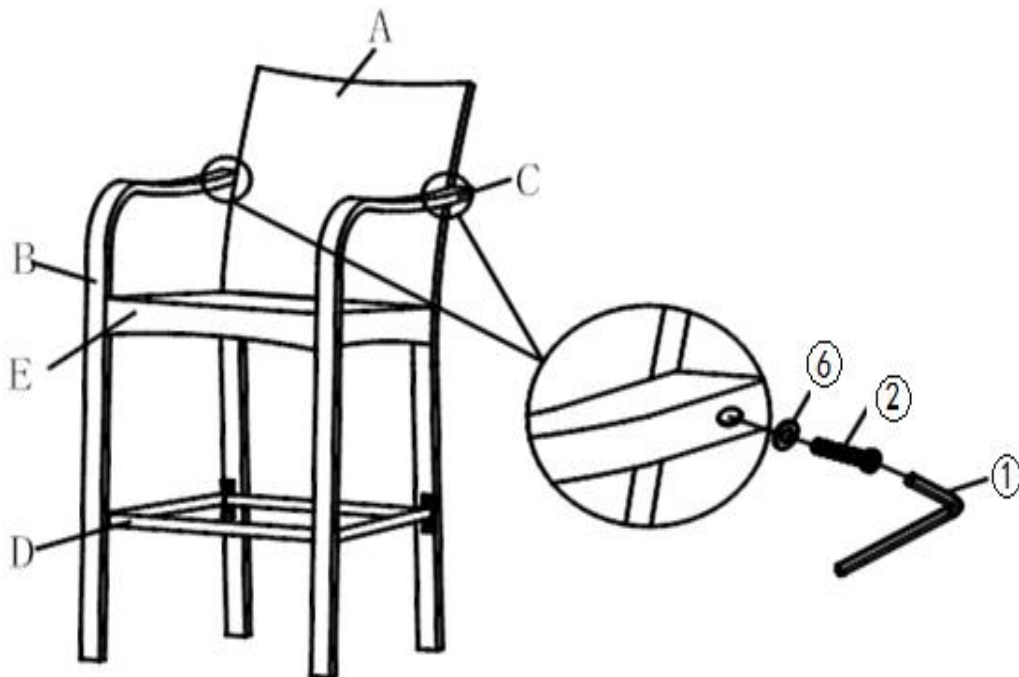

Use bolts (2) and washers (6) to connect the back end of the Left Armrest (B) to the Backrest (A). Then use bolts (2) and washers (6) to connect the back end of the Right Armrest (C) to the Backrest (A).

Note: Do not use the Allen Key (1) to tighten the bolts completely until all parts are assembled.

## Step 6

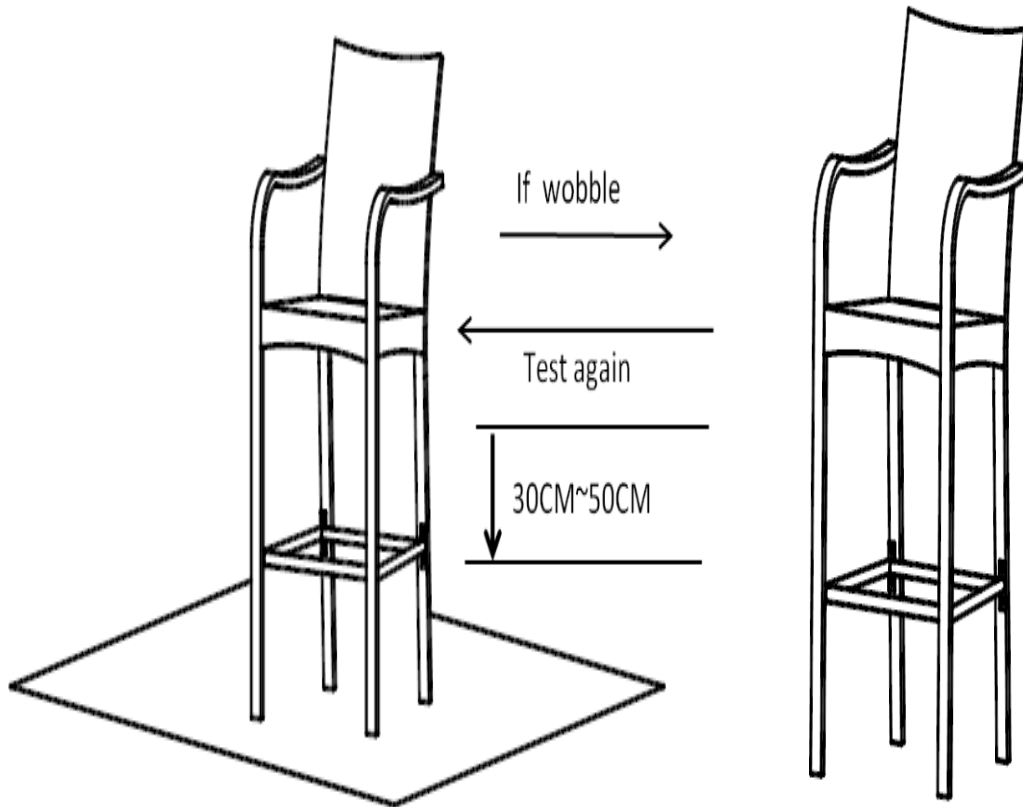

Place the barstool on a LEVEL SURFACE to check for wobbles.

If it wobbles lift the barstool to some 20cm to 30cm height from the ground.

Keep your feet and toes well away from the drop zone.

Drop the barstool freely and vertically with the four legs, hitting the ground, all at the same time.

This Drop Test will help to ensure that all the bolts and gaps reach full alignment status.

Test again for evenness on a LEVEL SURFACE.

If no wobbles are found, slowly and steadily turn the barstool upside down.

Then proceed to tighten all bolts in a sequential manner.

**CAUTION :** When tightening these bolts, tighten sequentially.

**DO NOT** tighten any bolt fully and then move on to the next one.

This could cause the frame to warp.

If it still wobbles after tightening, loosen the bolts and execute the same drop test again.

**WARNING!!** IF THE BARSTOOL IS NOT STABLE , IT COULD LEAD TO DAMAGE OF THE PRODUCT.

## Step 7

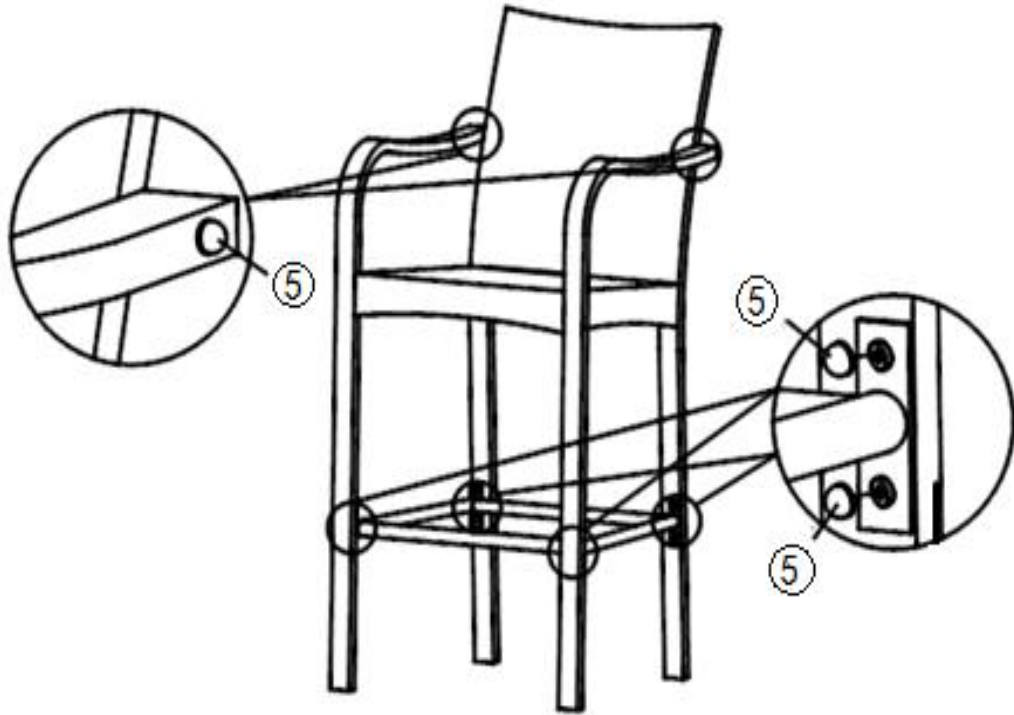





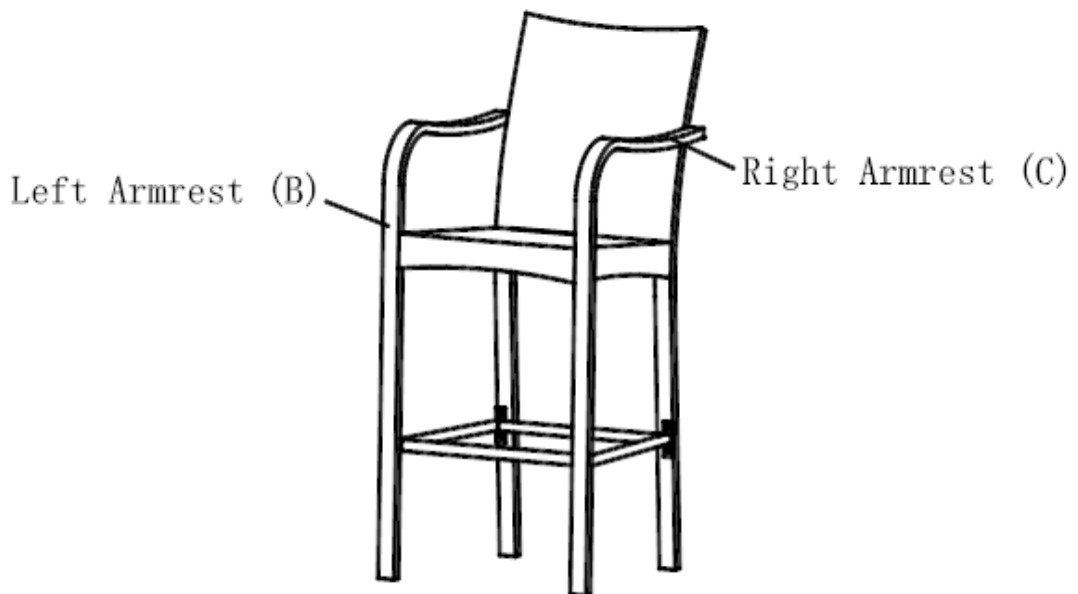















Cover all bolts with Bolt Caps (5).

## Step 8



Your Barstool is ready for use.

## Care & Maintenance

-   ● Do not put hot items directly on furniture surface
  -   ● Do not clean furniture with harsh cleansers or polish.
  -   ● To obtain the longest lifespan of your outdoor products, minimizing exposure to direct sunlight is recommended.
  -   ● Children should not climb or jump on the furniture.
  -   ● Do not write on furniture without a padded barrier to protect the surface.
  -   ● To obtain the longest lifespan of your outdoor products, avoid extended and lengthy exposure to rain, snow, and direct sunshine. Whenever possible cover the product and /or place under patio or awnings.
  -   ● Not for commercial use. For residential use only .
  -   ● Stains may be removed with mild soap solution and damp cloth.
  -   ● Keep away from sources of ignition.
- 
-   ● Dust and pick-up spills using a clean, non-colored, lint-free cloth.