

8x8



Dear Customer,
Thank you for purchasing our products,
we hope that it will give you many years of enjoyment.
If you have any queries at all then please contact us

**These instructions are for your safety. Please read through them thoroughly before use .
PLEASE KEEP THIS BOOKLET FOR FUTURE REFERENCE**

Let's get started...



Important information...

Safety	02
Base and positioning	03
Warranty	03
Before you start	04
Care maintenance & Recycling	05



In more detail...

Hardware chart	06
Parts List	07
Detailed Technical Drawing	08
Assembly instructions	10-21

EN	For a copy of the instructions or a copy in another language please send an email or write to the address below.
F	Pour obtenir un exemplaire des instructions ou une copie dans une autre langue s'il vous plaît envoyez un e-mail ou écrivez à l'adresse ci-dessous.
PL	Na kopii instrukcji lub kopii w innym języku prosimy o wysłanie maila lub pisać na adres podany poniżej.
RUS	Для получения копии инструкции или копия на другом языке, пожалуйста, отправьте по электронной почте или написать по указанному ниже адресу.
TR	Başka bir dilde talimatları veya bir kopyasını bir kopyası için bir e-posta gönderebilir veya aşağıdaki adrese yazınız.

Check that you have noted all the following instructions



- We advise the use of non slip protective gloves throughout the assembly process.
- We advise the use of steel capped protective footwear throughout the assembly process
- We advise the use of protective headwear and safety goggles throughout the assembly process
- Where a ladder is in use another person must hold the ladder.
- Do not attempt to work in windy conditions
- We advise the use of a scaffold tower when fitting the roof , for felting or if you cannot reach from the ground.
- Do not allow children near the tools and work area
- Follow any safety precautions quoted by the manufacturer for any equipment you use
- Check all parts before assembly
- Only use child and animal safe wood preservative
- Do not use creosote
- Allow the wood preservative to fully dry before use
- Regularly check the building for wear and tear

Important!



EVERY PRECAUTION IS TAKEN TO ENSURE THAT YOUR BUILDING HAS NO ELEMENT INCORRECTLY PLACED OR POSSIBLY HAZARDOUS, HOWEVER PRIOR TO USE PLEASE CHECK ALL SURFACES FOR THE FOLLOWING:

- (1) RAISED GRAIN, SPLINTERS: Sand down timber to smooth finish
- (2) NAIL/SCREW/PIN HEADS PROUD: Tap home to be flush with surface of timber
- (3) DAMAGED SCREW HEADS RESULTING IN SHARP SPLINTERS OF METAL: Replace
- (4) SHARP ENDS OF NAILS/ SCREWS/ PINS PROTRUDING THROUGH THE PANEL: Remove and reposition.
- (5) ENSURE ALL PARTS ARE SECURED AGAINST REASONABLE FORCE: Remove and refit
- (6) ENSURE THERE ARE NO LOOSE PARTS: Remove and refit/discard



IMPORTANT ! For your safety please read carefully the safety warnings

Preparation of base...

We recommend that the base onto which your building will stand should be at least 75mm larger in each direction than the total floor size of the building.

Actual floor area of the building: 2248mm x 2248mm

Total height clearance: 2140mm

The chosen position in your garden for the siting of the building should be excavated to a depth of 75mm to allow a base of sand, on to which paving slabs can be evenly laid.

You may also use an adjustable timber base or a concrete base. Whatever base you decide upon IT MUST BE LEVEL AND FIRM.

Warranty...

10 Year anti rot warranty subject to the following -

- The building must be raised so it is not in contact with any water retaining base surface (for example grass).
- This can be achieved using a timber, concrete or slab base
- When using a concrete or slab base use damp proofing strips under the bearers
- The building must have been completely treated and sealed immediately prior to or after assembly
- The building must have been re-treated and re-sealed annually
- If your building has been pressure treated or has any pressure treated parts additional treatment need not be applied (except for aesthetic purposes)
- Wood is a natural product and therefore the following are excluded from the warranty
 - Colour changes
 - Warping
 - Splitting

The following are also excluded

- Damage resulting from poor assembly
- Poor treatment application
- Poor care and maintenance
- Changes to the design
- Misuse
- General wear and tear

Things to check before you start





- ✓ Ensure your base is ready– See page 3
- ✓ Check all parts as listed in the parts lists
- ✓ Read the instructions fully before starting work
- ✓ Follow all the health and safety guidelines

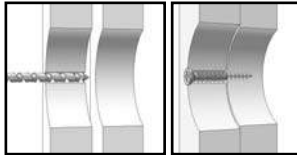





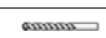



When you see the drill icon
Only ever drill through the first piece of framework which will be a pilot hole for the screw to attach the second piece of framework
The required drill bit size is shown with the icon.

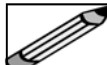

You will need

-  • Hammer
-  • Spirit level
-  • Ladder
-  • 1mm, 3mm & 6mm drill bit
-  • Drill
-  • Tape measure or Ruler
-  • Sand paper

-  • Gloves
-  • Saw
-  • Pencil
-  • Goggles
-  •
-  • A helper for some tasks
-  • Screwdriver
-  • Sharp knife

The 5 golden rules of care

- (1) Ensure your base is level and firm
- (2) Ensure the building is not sitting directly on the ground using damp proof membrane or the optional timber base.
- (3) Ensure every piece of timber and surface, especially that which will be hidden upon assembly is treated with a top quality wood preservative at least twice (see note on pressure treated buildings in warranty section)
- (4) Garden buildings are not waterproof we recommend you seal between all the panels with a silicone based sealant .
- (5) Regularly check your roofing felt for weather damage and leaks

The 7 golden rules of maintenance

- (1) Re apply the timber treatment annually. (see note on pressure treated buildings in warranty section)
- (2) Visually check for weather damage
- (3) Check and replace if necessary any Silicone sealant if used on your building.
- (4) Check the roofing material for wear
- (5) The doors and windows may require periodical adjustment
- (6) Ensure your building is well ventilated especially during hot weather
- (7) During extremely hot periods humidify your building to prevent the timber from drying out .and shrinking

Recycling and disposal



packaging











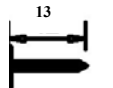

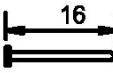
1. Pallet and timber widely recycled
2. Cardboard widely recycled
3. Plastic strapping subject to local regulations
4. Plastic sheeting subject to local regulations

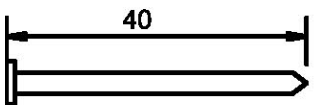

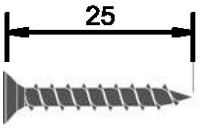

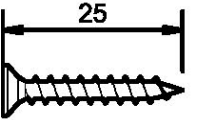

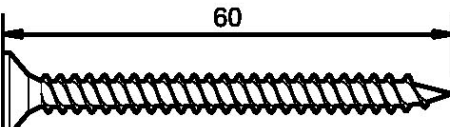

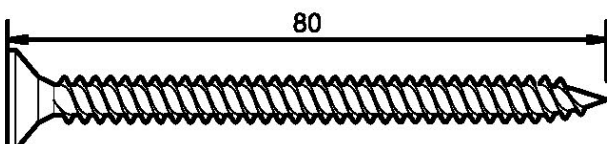

Building

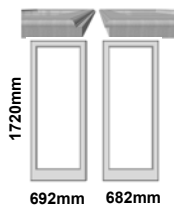
1. Timber widely recycled
2. Metal fixings widely recycled
3. Glass widely recycled
4. Roofing felt not currently recycled

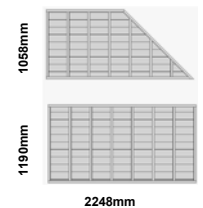
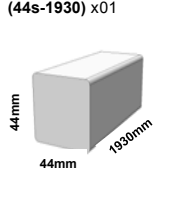
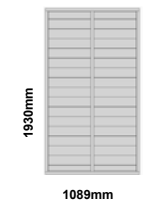
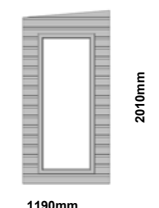
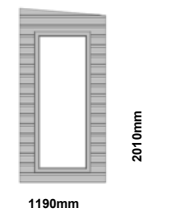
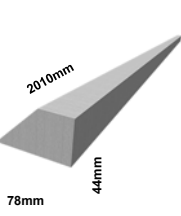
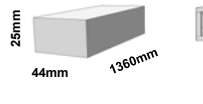
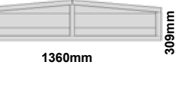
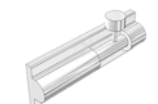
Hardware Chart Scale 1:1

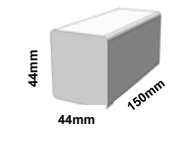
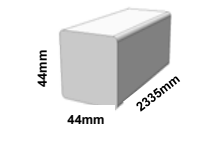
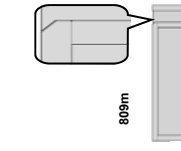
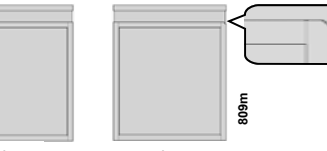
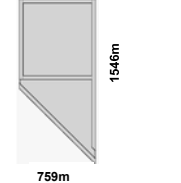
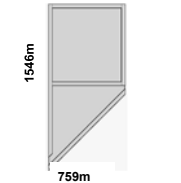
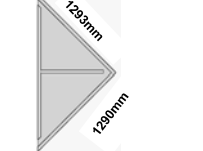
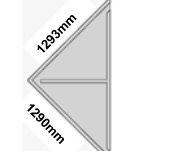
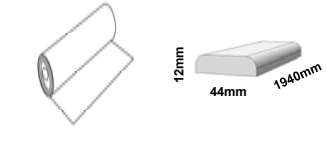
Felt Nail (13mm FN) x150		 13
Panel Pin (16mm PP) x200		 16
Round head nail (40mm RH) x56		 40
Black Posi-drive screw (25mm BLK) x12		 25
Posi-drive screw (25mm) x54		 25
Posi-drive screw (60mm) x62		 60
Posi-drive screw (80mm) x06		 80

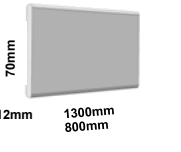
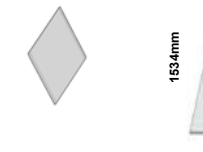
Parts List ...Not to scale

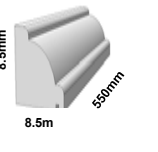
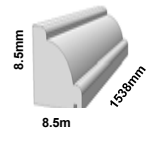
Doors LH A1316 RH A1315  1720mm 692mm 682mm	Door Hinge (STH) x06 	Floor panels (FP-114) x01 pair  1058mm 1190mm 2248mm	44s framework Square corner post (44s-1930) x01  44mm 44mm 1930mm	Plain Panel (PP25) x04  1930mm 1089mm	Window Panel LH (A1419) x01  2010mm 1190mm
Window Panel RH (A1418) x01  2010mm 1190mm	Angled door post (78R-2010-45) x02  2010mm 78mm 44mm	44D framework Door step (44dD-1360) x01  25mm 44mm 1360mm	Gable Panel; (A1318) x01  1360mm 308mm	Door barrel bolt (DB) x02 	Turn button (TB) x02 
Gate Latch set (GL) x01 	44s framework Truss block (44s-150) x02  44mm 44mm 150mm	44s framework Truss (44s-2335) x01  44mm 44mm 2335mm	Front LH Roof panel From inside looking forward (RP103-LH-F) x01  809mm 759mm	Front RH Roof panel From inside looking forward (RP103-RH-F) x01  809mm 759mm	
Back LH Roof panel From inside looking forward (RP103-LH-B) x01  1546m 759m	Back RH Roof panel From inside looking forward (RP103-RH-B) x01  1546m 759m	LH Roof panel From inside looking forward (RP104-LH) x01  1233mm 1230mm 1230mm	RH Roof panel From inside looking forward (RP104-RH) x01  1233mm 1230mm 1230mm	Felt strips (FLT-3.7m) x02 (FLT-2.1m) x01  12mm 44mm 1940mm	
Profiled cover strip (34C-1990) x02 	Fascia (70FC-1300) x02 (70FC-800) x02  70mm 12mm 1300mm 800mm	Diamond (DI) x01 	Plastic Glazing (PX-547-1534) x04  1534mm 547mm	Beading (8.5B-550) x08  8.5mm 8.5m 550mm	Beading (8.5B-1538) x08  8.5mm 8.5m 1538mm

In more detail.....

In more detail.....

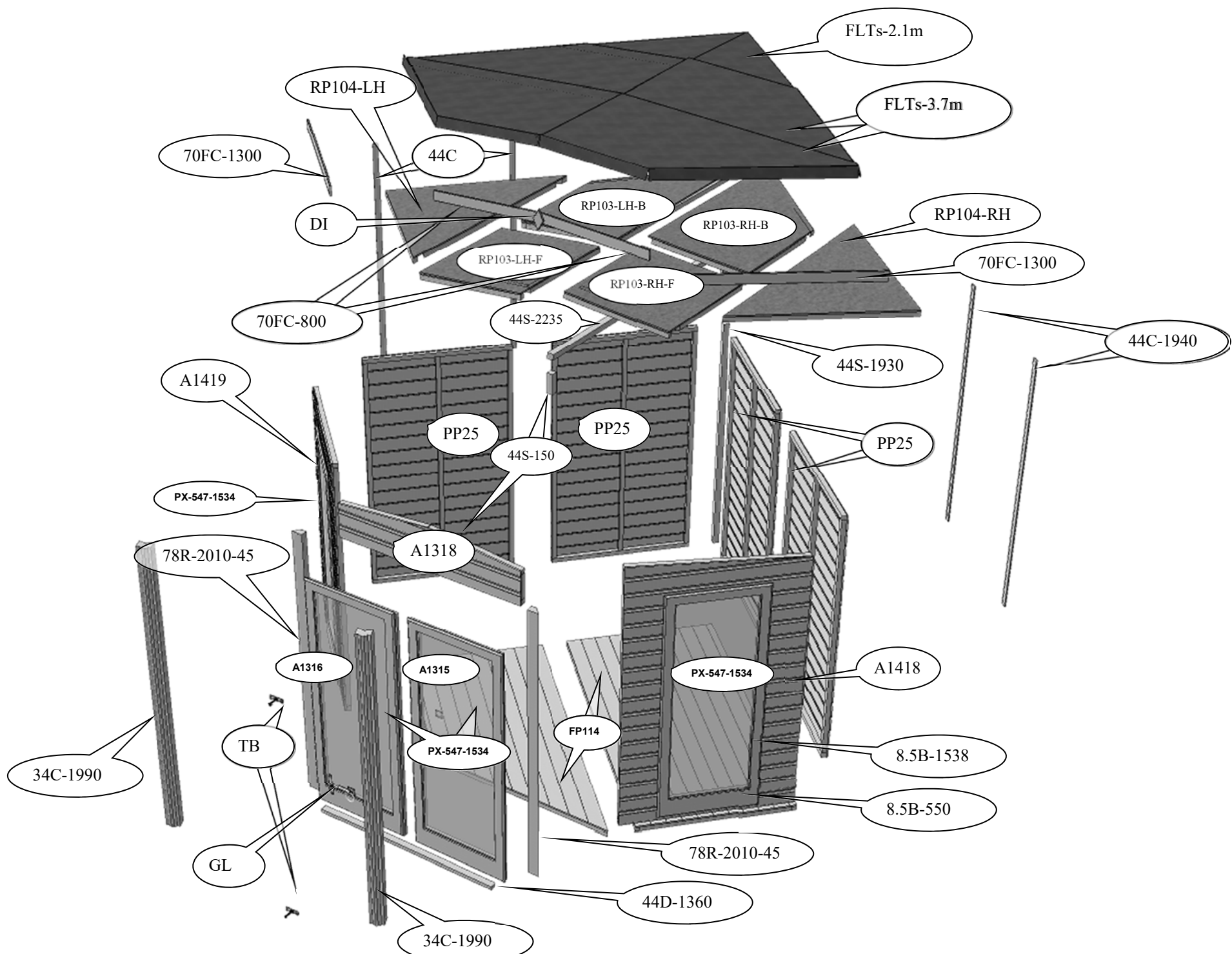

In more detail.....

In more detail.....

View from above and enlarged corner details

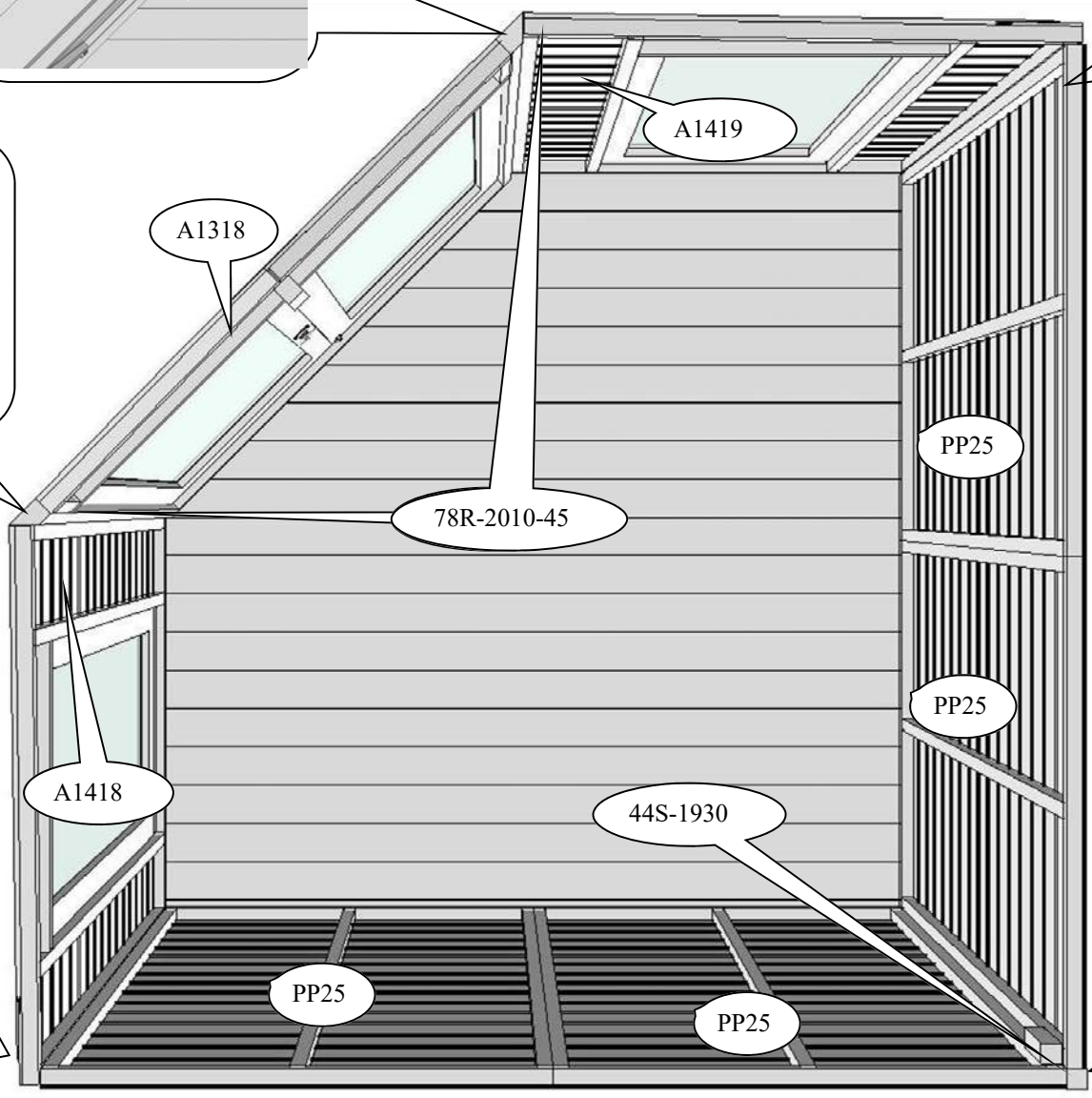
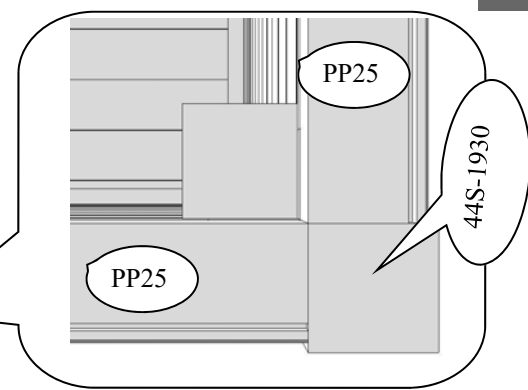
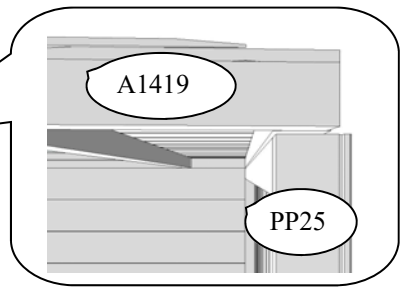
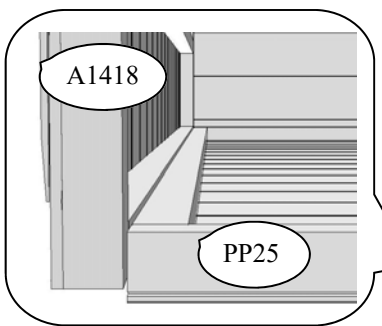
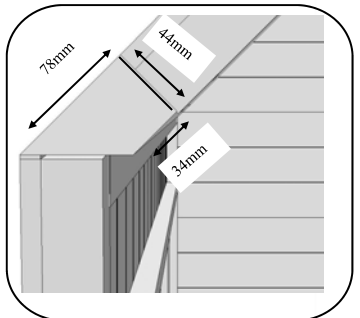
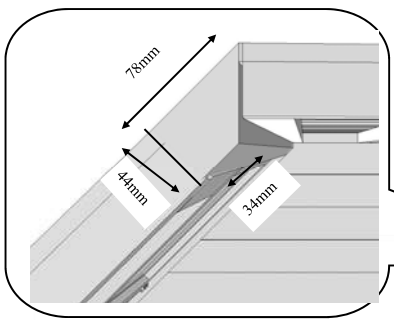

Assembly

These instructions are for your safety. Please read through them thoroughly before use .
Treat all the parts before assembly –see page 5

GB-IE Attach the smaller inner part of 3 of the hinges on the long edge of each of the doors.

01



Doors
(A1316 A1315)



Door hinge
(STH)x06

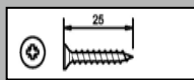

Screw
(25mm)x12

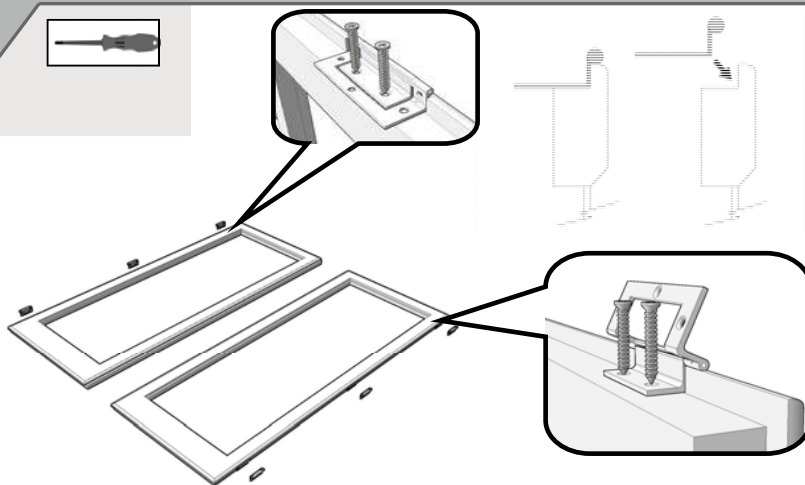

GB-IE Stand both floor panels on edge, drill one floor panel and screw them together.
Lay your floors in position on your base.

02

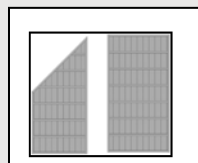

Floor
(FP114) x01 pair

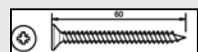

Screw
(60mm)x04

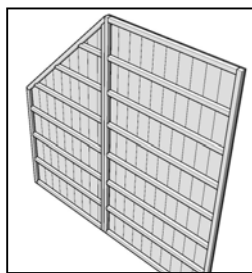
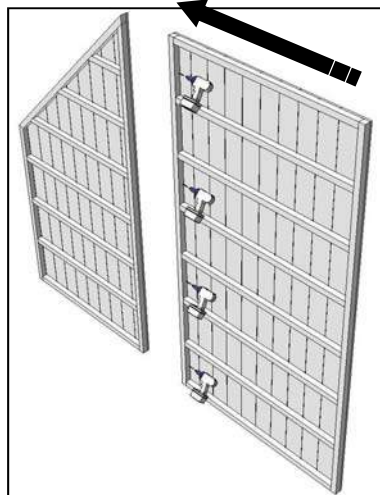

GB-IE

Attach the plain panel "PP25" to the post "44S-1930" so the post is flush with the framework and the face of the cladding. At the bottom the post is flush with the framework.

03

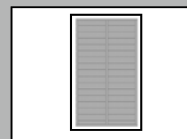

Plain panel
(PP25 x01)

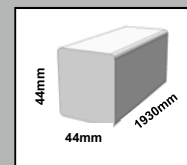

Corner post
(44S-1930) x01

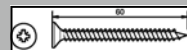

Screw
(60mm)x03

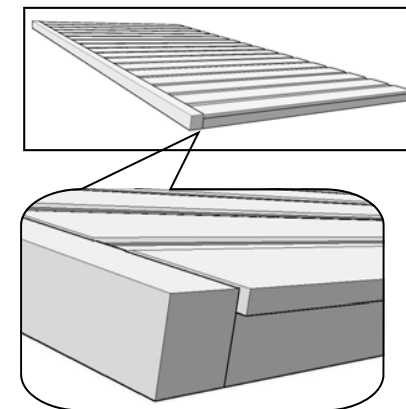
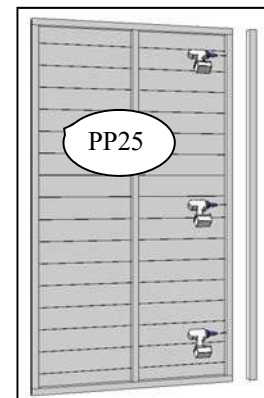
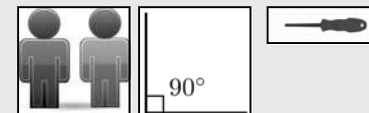

GB-IE

Place the panel from step 3 in the corner.
Position & fix another "PP25" plain panel against the post as above so the post overhangs the floor and is not seen from inside the building.

04

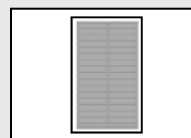

Plain panel
(PP25 x01)

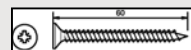

Screw
(60mm)x03

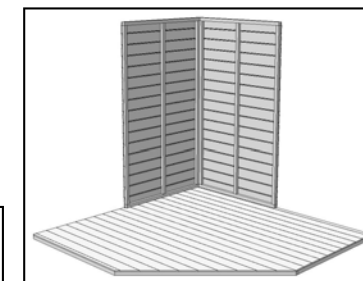
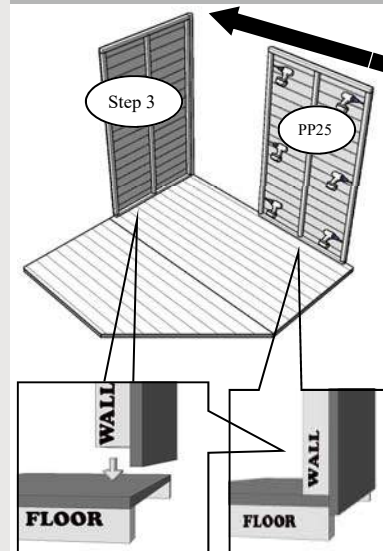

GB-IE

Add two more plain panels "PP25".
This will leave a 34mm step on both corners to the edge of the floor.

05

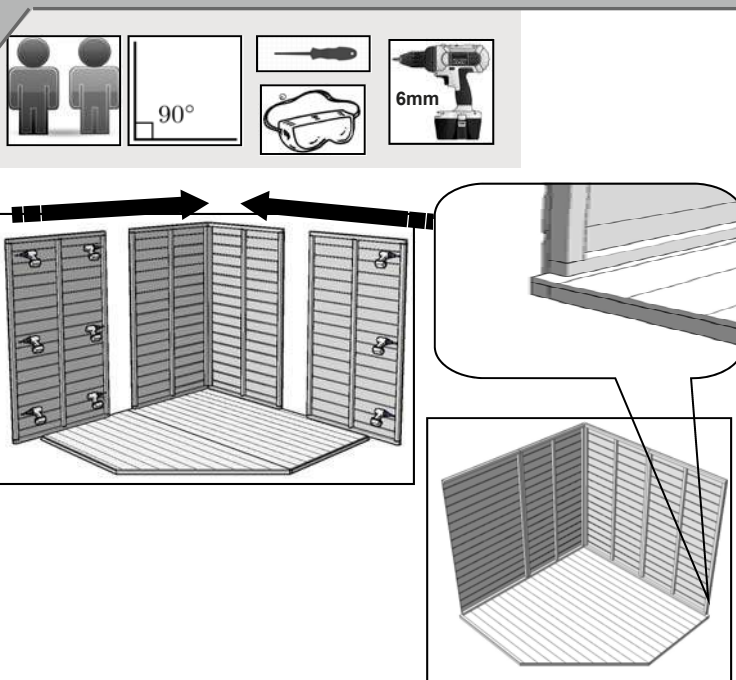

Plain panel

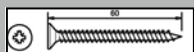

Screw
(60mm)x06

GB-IE

Place one Angled door post '78R-2010' at the edge of one window panel. The wider part of the post should be flush to the front of the window panel and the sawn edge should rest against the window panel. The post should rest on the floor, but will overhang slightly. Drill/screw into position through the panel framework into the post using 3x 60 mm screws. Repeat at other side.

07

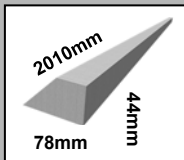

Angled door post
(78R-2010-45) x02

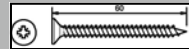

Screw
(60mm)x06

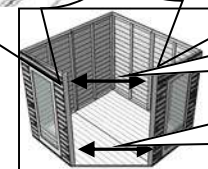
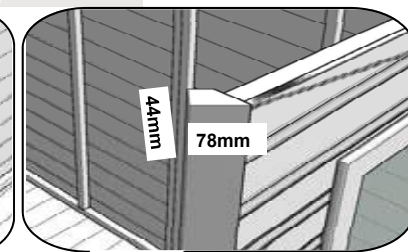
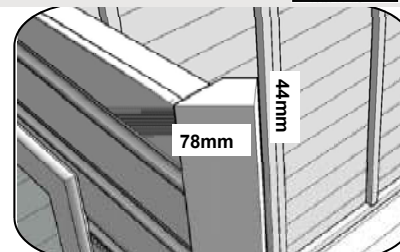
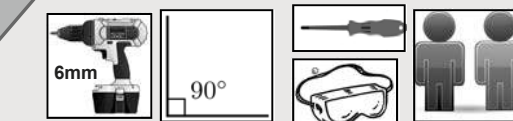

MUST BE
1360mm
between posts

GB-IE

Position and fix the two window panels, the panels will be flush with the corners.
Drill 3 holes per window panel to fix the step 10 "78R-2010-45" angled posts

06

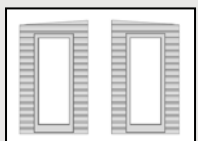
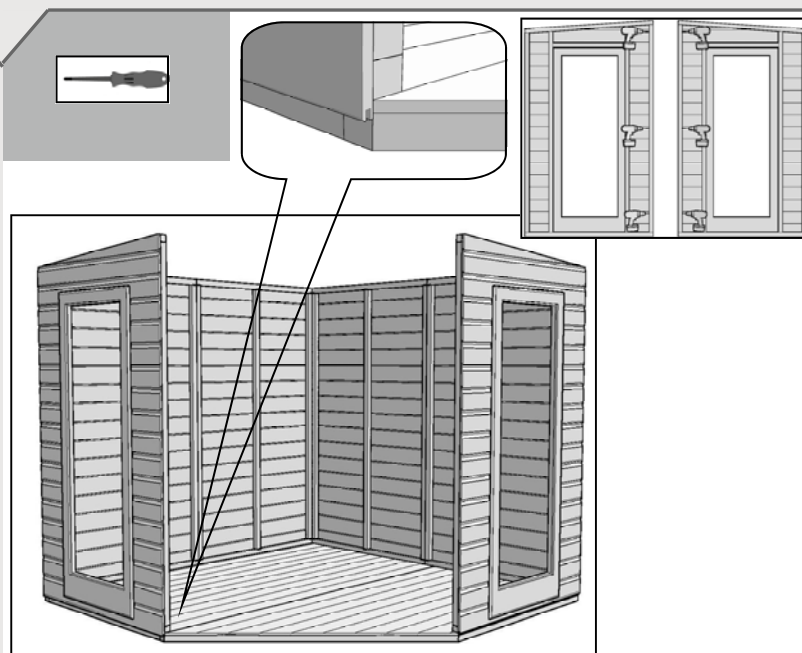

Window panel
(A1419 & A1418)

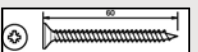

Screw
(60mm)x06

08

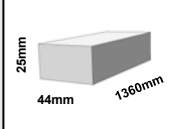

Door step
(44D-1360)x01



Gable Panel
(A1318)X01



Screws
(60mm)x19
(80mm)x2

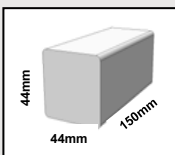

Truss block
(44S-150)x01

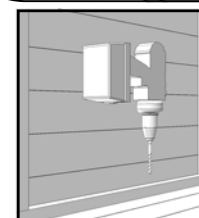
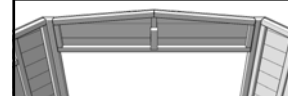
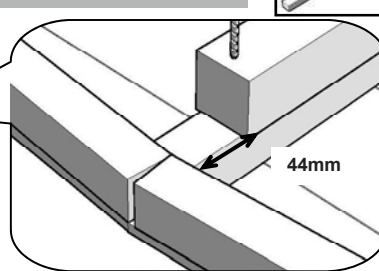
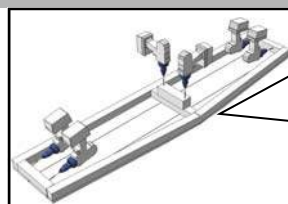
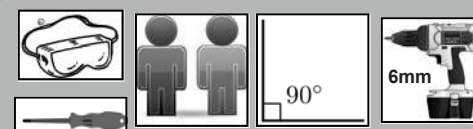

GB-IE Fix both doors leaving an even gap top and bottom with 1 x 25mm screw at first to the angled posts at each of the hinges
Adjust the door if necessary and fit the remaining screws

GB-IE Position the Gate latch "GL" on the outside over the **primary door** framework.
Mark the screw holes as shown. Drill the middle hole only and fit the "SQUARE SHAFT" in the hole,
locate the two ring handles onto the shaft and fix to the door
Align and fit the catch plate to the secondary door.

09

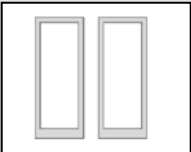

Doors (step1)x01 pair

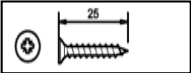

Screw (25mm)x30

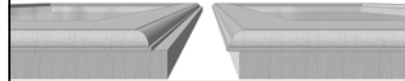
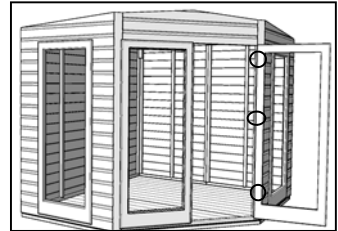

Secondary door Bolted Primary door Opening first

View on bottom of doors

12



Gate latch set (GL) x01

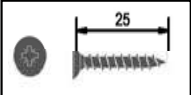

Black Screw (25mm)x10

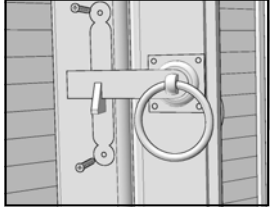
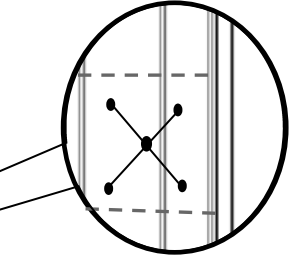
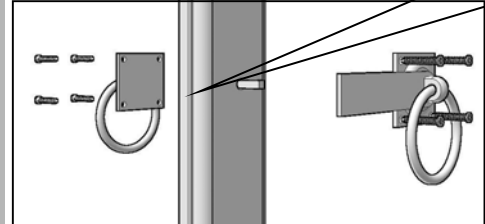
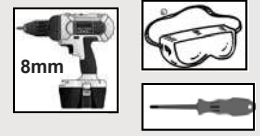

GB-IE Fix a bolt at the top and bottom of the secondary door, mark where the bolt strikes the frame and drill an 8mm hole to take the bolt.

GB-IE On the inside back corner fit a truss block 78mm down from the top with 2x 80 mm screws. Position the truss on this block and the one fitted in step 8 to the gable. Pre drill the truss and fix with 2x80mm screws. **The truss will sit 34mm below the top of the panels (for the roof frame work).**

10



Door barrel bolt (DB)x02

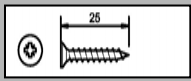

Screw

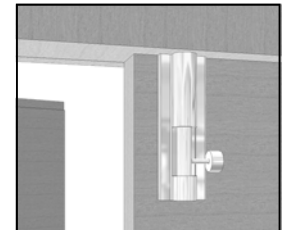
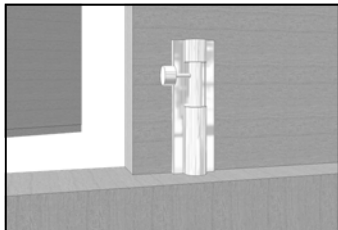
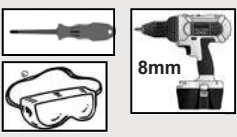

GB-IE Fix a turn button to the top and bottom of the secondary door so they hold the primary door shut. This is to help with natural timber movement during different weather conditions. Failure to fit these turn buttons may result in the doors bowing.

13

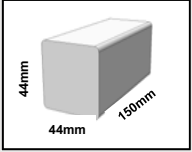

Truss block (44S-150)x01

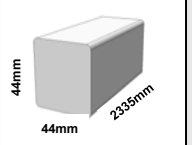

Truss (44S-2335)x01

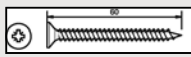

Screw (80mm) x04

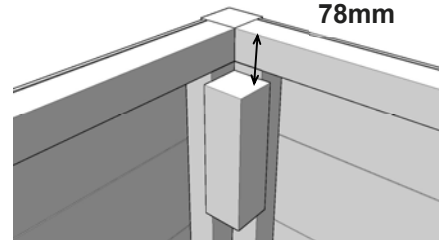
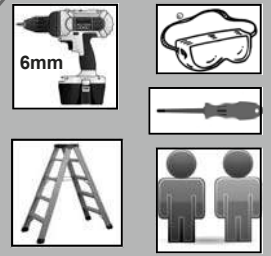

11



Black Turn button (TB)x02

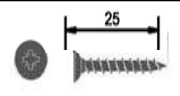

Black Screw (25mm)x2

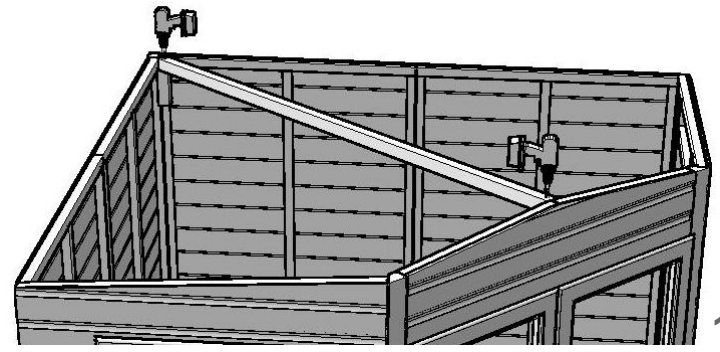
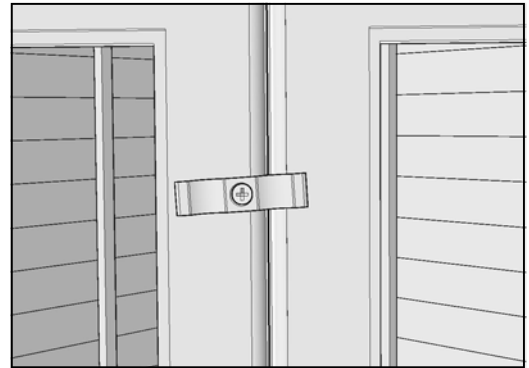

16

17

GB-IE When joining the roof panels "RP103" together ensure the chamfered corners are positioned correctly.

GB-IE Place the roof panels into position without fixing at this stage as it may be necessary to make adjustments to get the best fit

14



Front LH Roof panel (RP103-LH-F) x01



Front RH Roof panel (RP103-RH-F) x01



Back LH Roof panel (RP104-LH-B) x01



Back RH Roof panel (RP1043-RH-B) x01

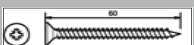

Screw

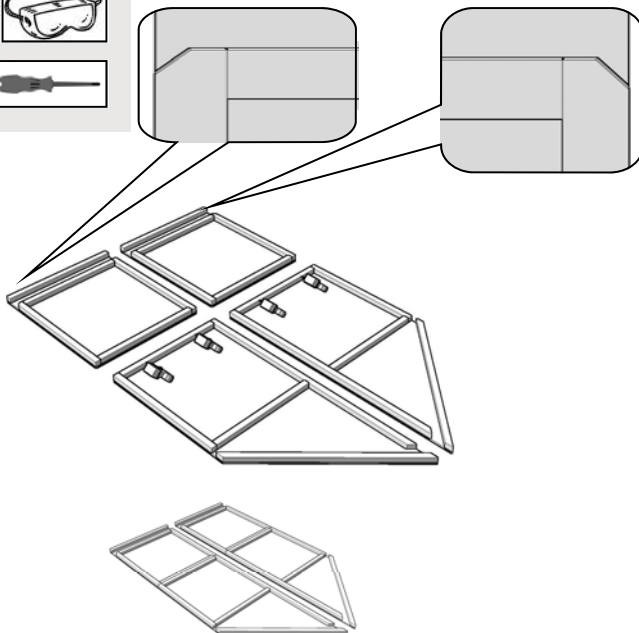

16

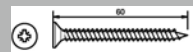
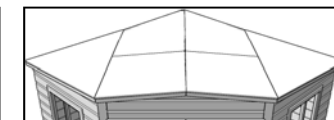
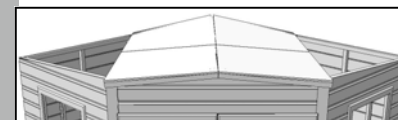
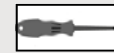
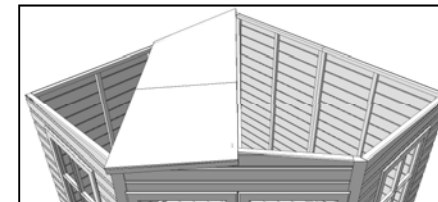

Screw (60mm)x11

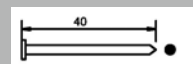

Nail (40mm) x16

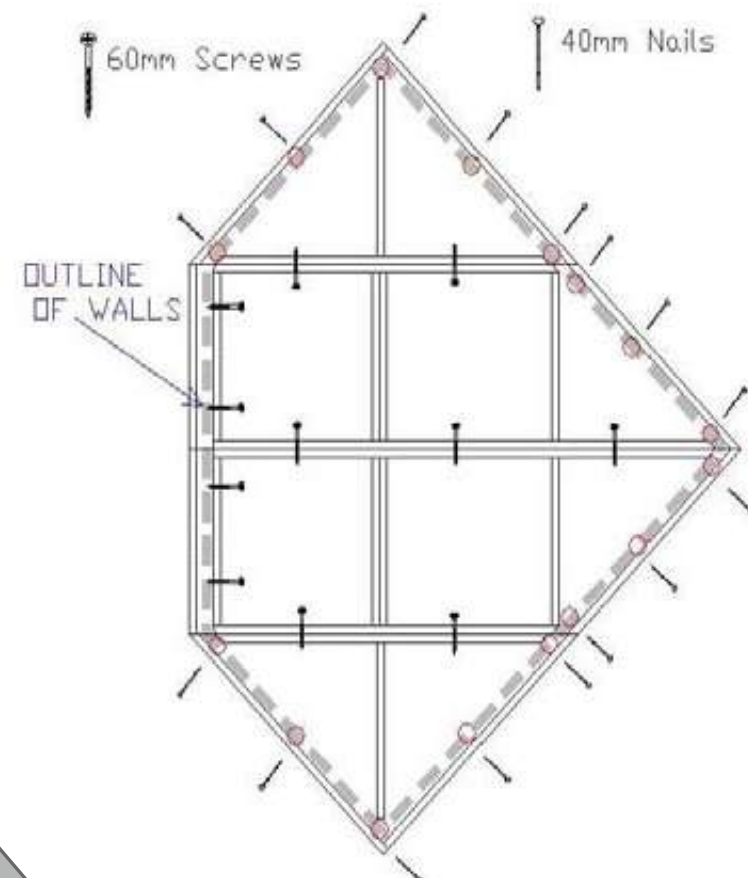

GB-IE Pre drill the roof panels only ready for fixing together when in position on the building.

15

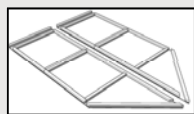

Assembly step



Roof Panel (RP104 RH) x01



Roof panel (RP104-LH) x01

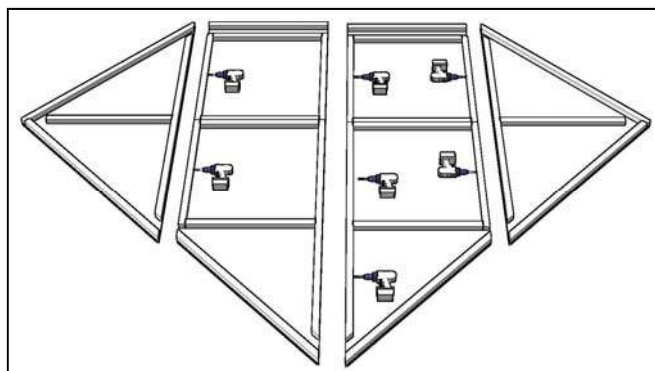

GB-IE Carefully screw the panels together using the pre drilled holes and also use 3 screws to fix to the gable. Nail through the roof panels into the top of the walls.

18

GB- Position all the felt, starting from the back, without fixing first to ensure you have an even overlap and at least 50mm to fold over the roof edgings and trim later .
Once you are happy with the positioning nail on top of the felt near the edge approximately 75mm apart.
Fold down the excess over the roof edgings fix as above and trim off the excess felt level with the bottom of the roof edging.

GB-IE Fix the fascias to the window panel first and then the gable with 3 nails each.
Fix the diamond over the fascia join with 3 nails

17

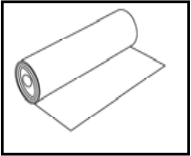

Felt strips
(FLTs-3.7m) x02
(FLTs-2.1m) x01

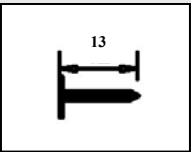

Felt Nail
(13mm) x150

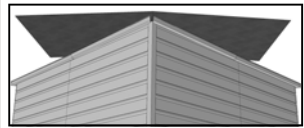
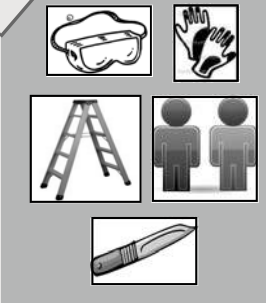

Reverse view

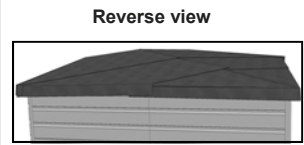

Reverse view

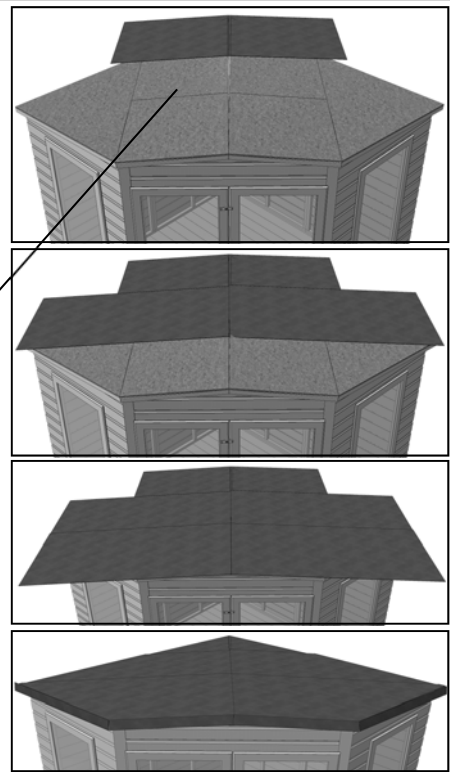

19

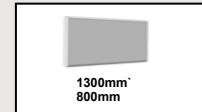

Fascia
(70FC-1300) x02
(70FC-800) x02

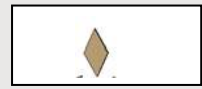

Diamond
(D1) x01

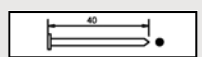

Nail
(40mm) x24

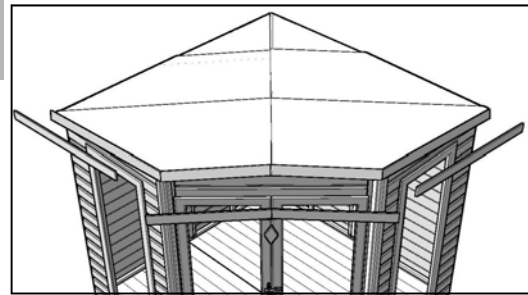
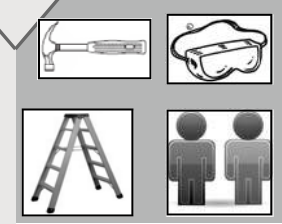

GB-IE Remove the protective film from both sides of the glazing material before fitting.
Nail the beading at approximately 100mm spacing

18

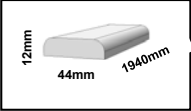

Cover strip
(44C-1190) x04

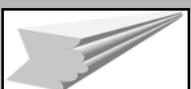

Cover strip
(34C-1990) x02

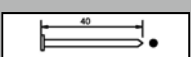

Nail
(40mm) x24



34C-1990

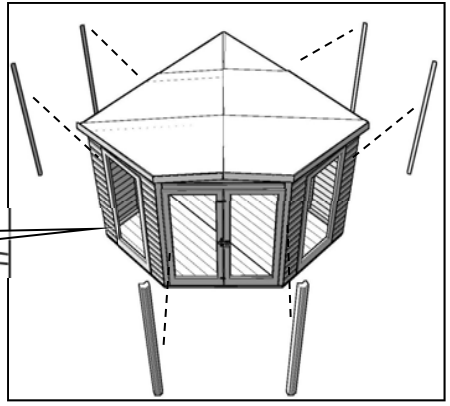

20

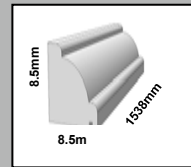

Beading
(8.5B-1538)X08

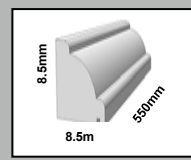

Beading
(8.5B-550)X8



Plastic Glazing
((PX-547-1534)) x04

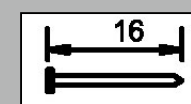

Panel pin
(PP 16mm) x200

