

# **ASSEMBLY INSTRUCTION**

**ASSEMBLY TIPS:**

- 1. Remove hardware from box and sort by size.
- 2. Please check to see that all hardware and parts are present prior to start of assembly.
- 3. Please follow attached instructions in the same sequence as numbered to assure fast & easy assembly.





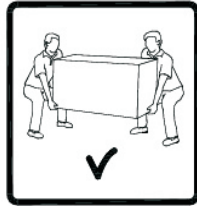

**Warning!**

- 1. Don't attempt to repair or modify parts that are broken or defective. Please contact the store immediately.
- 2. This product is for home use only and not intended for commercial establishments.



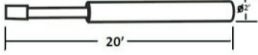

<b>ASSEMBLY TIME</b>	<b>5 MINUTES</b>
----------------------	------------------

**PARTS IDENTIFICATION**

	<b>PART NAME</b>	<b>FIGURE</b>	<b>QTY</b>
<b>A</b>	<b>SEAT AND BACK</b>		<b>1PC</b>
<b>B</b>	<b>FOOT REST</b>		<b>1PC</b>
<b>C</b>	<b>GAS CYLINDER</b>		<b>1PC</b>
<b>D</b>	<b>BASE</b>		<b>1PC</b>
<b>E</b>	<b>DECORATIVE RING</b>		<b>1PC</b>

**HARDWARE IDENTIFICATION**

	<b>HARDWARE NAME</b>	<b>FIGURE</b>	<b>QTY</b>
<b>1</b>	<b>BOLTS 3/16"x16MM</b>		<b>4PCS</b>
<b>2</b>	<b>ALLEN WRENCH M6</b>		<b>1PC</b>

**STEP1**

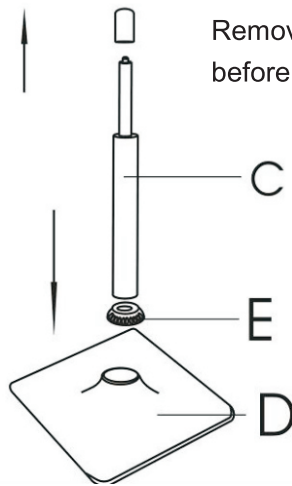

**STEP2**

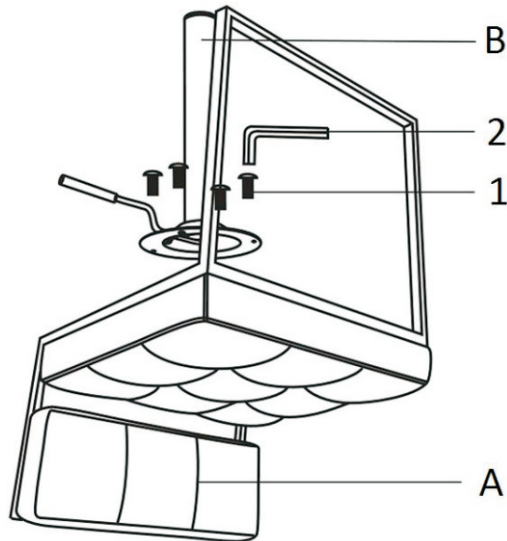

**STEP3**

Firmly push top into  
gas spring

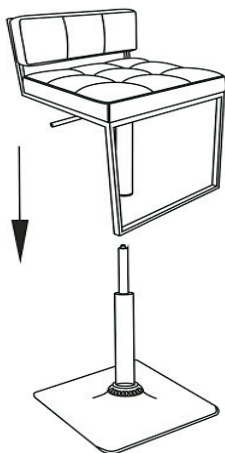

**STEP4**

