

注 意

用合适的螺丝能预防损坏这些组件

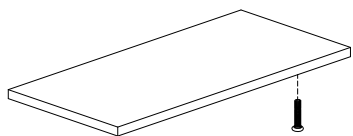

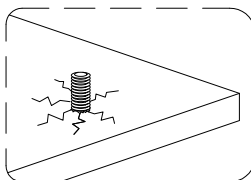





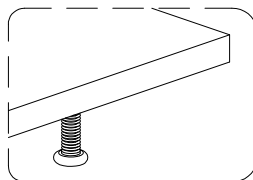

示例

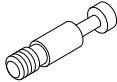
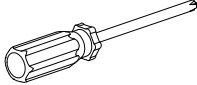
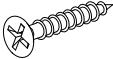
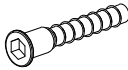

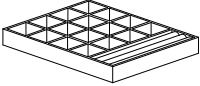
错误：螺丝会导致木板裂开



正确：螺丝是正确尺寸

<p>A X26+2</p>  <p>15*9MM</p>	<p>B X26+2</p>  <p>L=35mm</p>	<p>C X1</p>  <p>6*128MM</p>
<p>D X24+2</p>  <p>8*25MM</p>	<p>E X2</p>  <p>M7*35MM</p>	<p>F X1</p>  <p>264*205*5mm 钢化</p>
<p>G X1</p>  <p>215*275*30mm</p>	<p>H X2</p>  <p>丝杆M6*12MM*1寸 总高38MM (不带刹车)</p>	<p>I X2</p>  <p>丝杆M6*12MM*1寸 总高38MM (带刹车)</p>
<p>J X1</p>  <p>开口14MM</p>	<p>K X1</p>  <p>M4*100MM</p>	<p>L X26+2</p>  <p>20MM</p>

步骤1

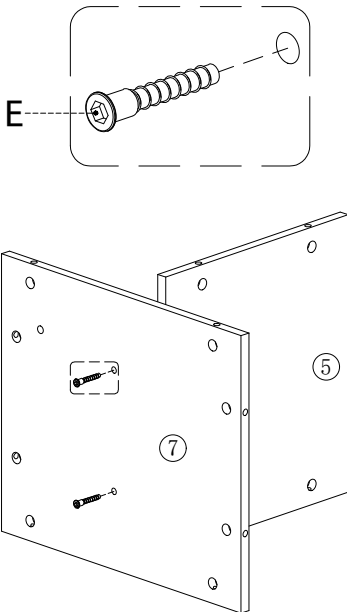

E		X2
K		X1

▶如图:将5号、7号部件用五金E/K组装。

步骤2

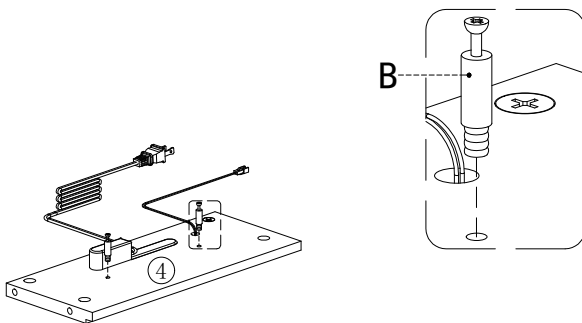

B		X2
C		X1

▶如图:将五金B用五金C组装到4号部件。

步骤3

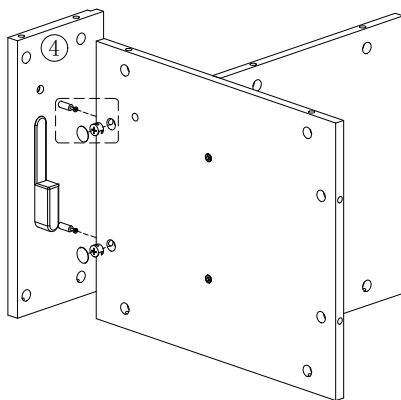
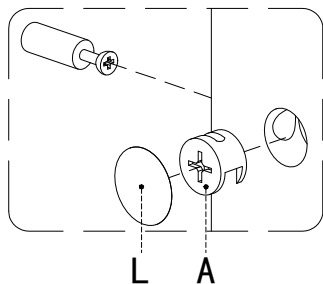

A		X2
C		X1
L		X2

▶如图:将步骤1与步骤2组好的部件用五金A/C/L组装。

步骤4

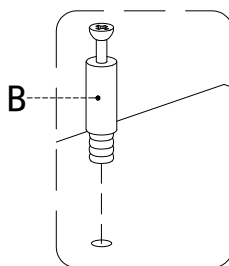
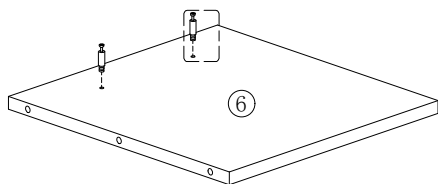



B		X2
C		X1

▶如图:将五金B用五金C组装到6号部件。

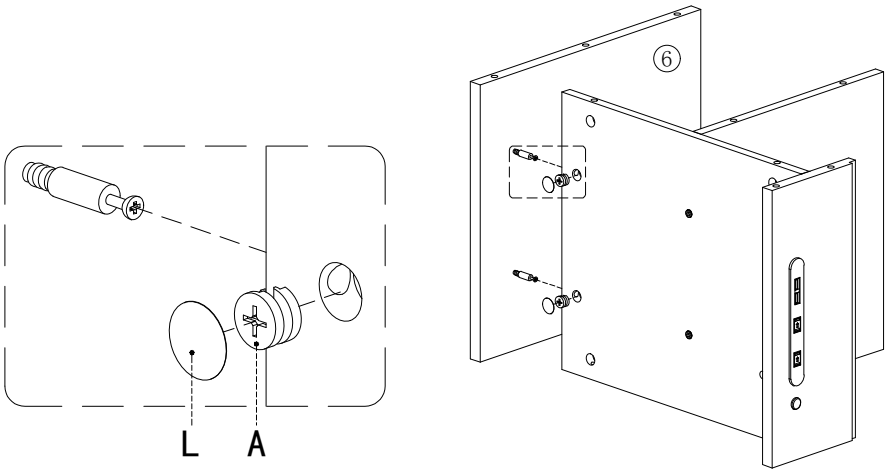
步骤5





A		X2
C		X1
L		X2

▶如图:将步骤3与步骤4组好的部件用五金A/C/L组装。

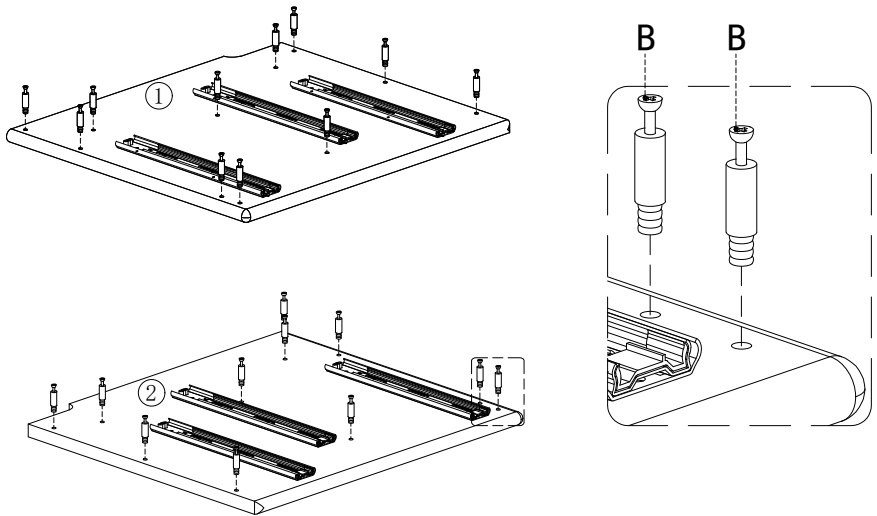
步骤6





B		X22
C		X1

▶如图:将五金B用五金C分别装到1号、2号部件。

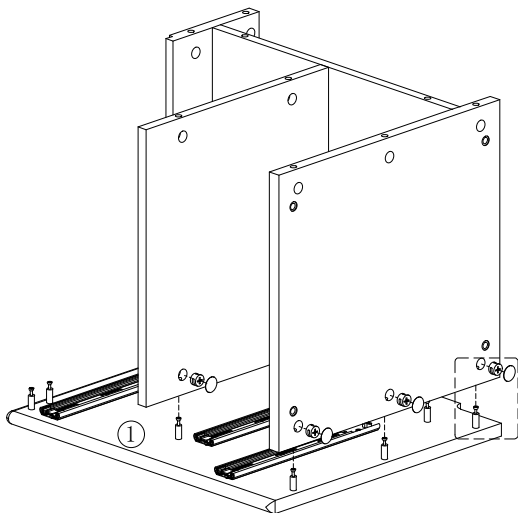
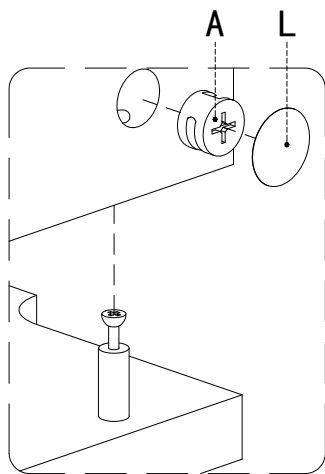
步骤7





A		X9
C		X1
L		X9

►如图:将步骤6组装好的1号部件与步骤5组装好的部件用五金A/C/L组装。

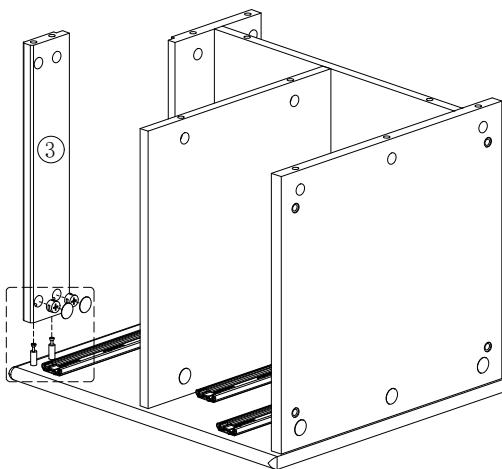
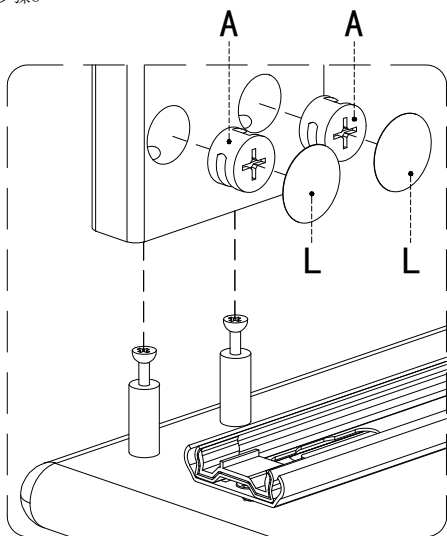
步骤8





A		X2
C		X1
L		X2

►如图:将步骤7组装好的部件与3号部件用五金A/C/L组装。

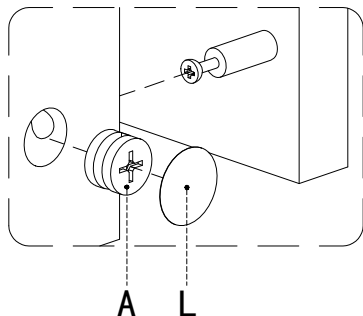
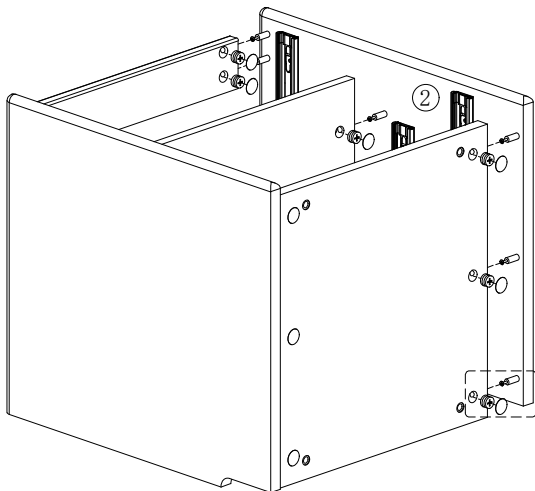
步骤9





A		X11
C		X1
L		X11

►如图:将步骤6组装好的2号部件与步骤8组装好的部件用五金A/C/L组装。

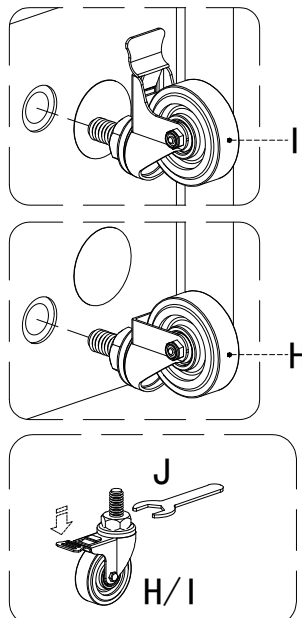
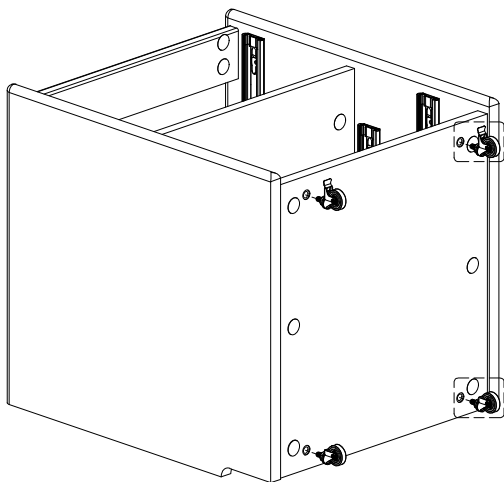
步骤10





H		X2
I		X2
J		X1

脚轮装好后,按如图所示开关可以控制脚轮转动

►如图:将五金H/I用五金J组装到步骤9组装好的部件底部。

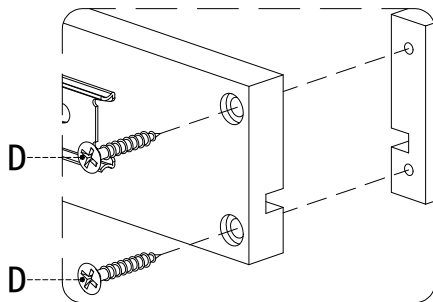
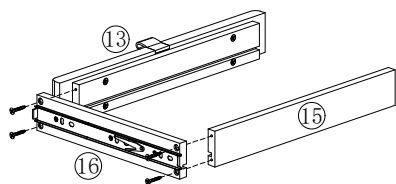
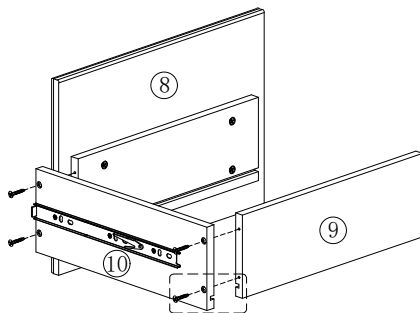
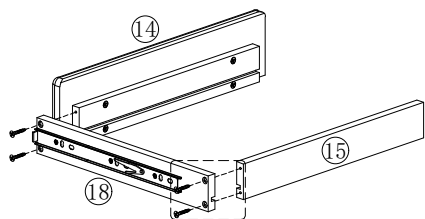
步骤11



C		X1
D		X12

▶如图:将8/9/10、13/15/16、14/15/18号部件用五金C/D组装。

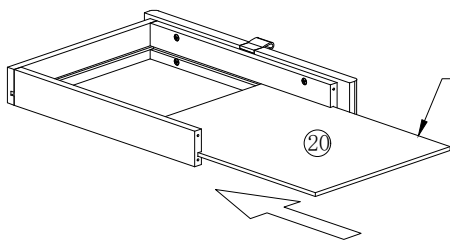
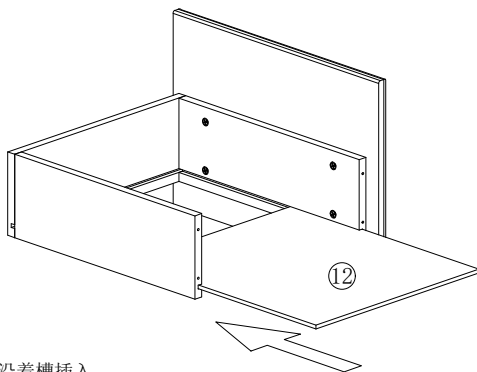
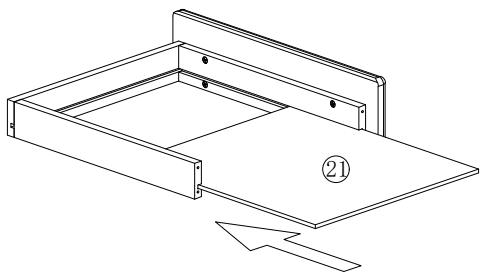

步骤12

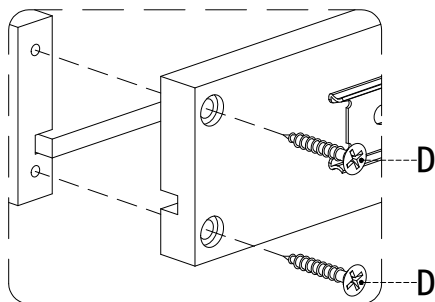
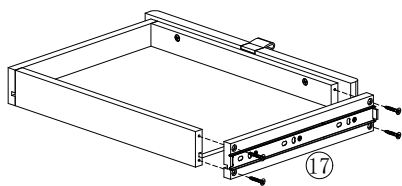
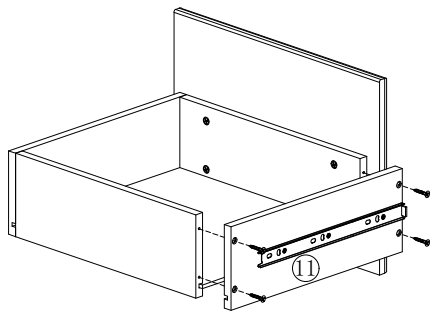
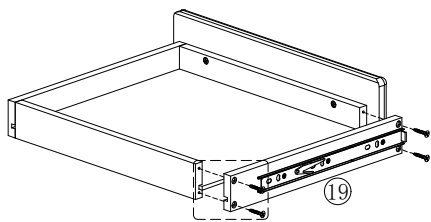

 底板沿着槽插入

步骤13



C		X1
D		X12

▶如图:将11、17、19号部件与步骤12组装好的部件用五金C/D组装。

步骤14

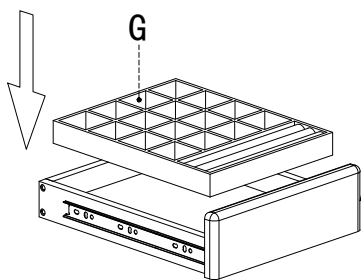

 放入首饰盒,注意抽屉面板的区别

步骤15

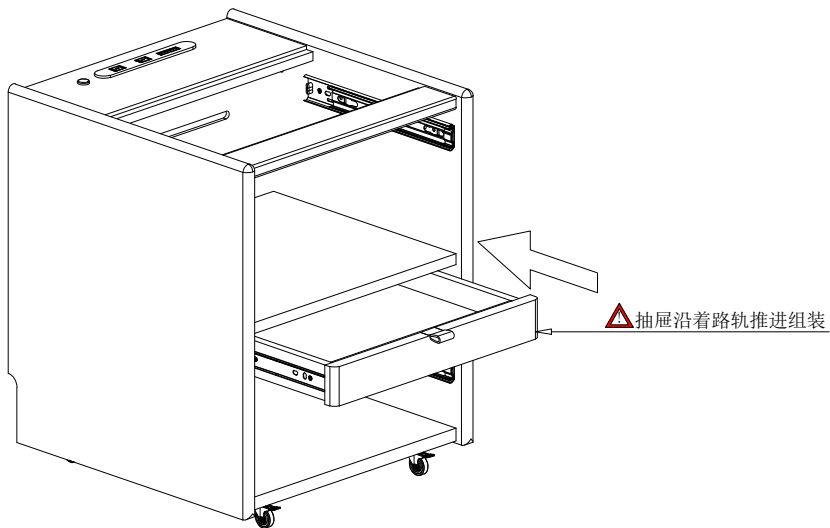

步骤16

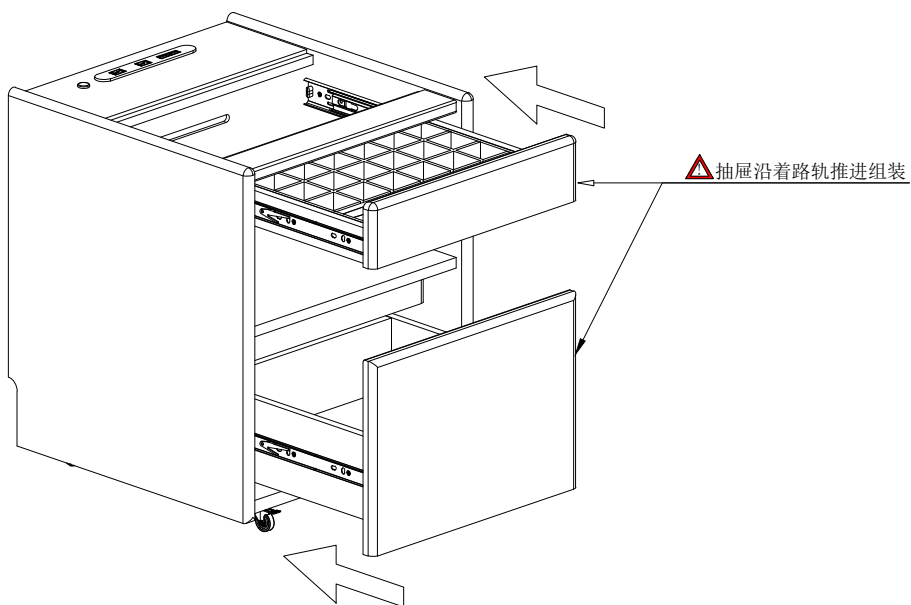

步骤17

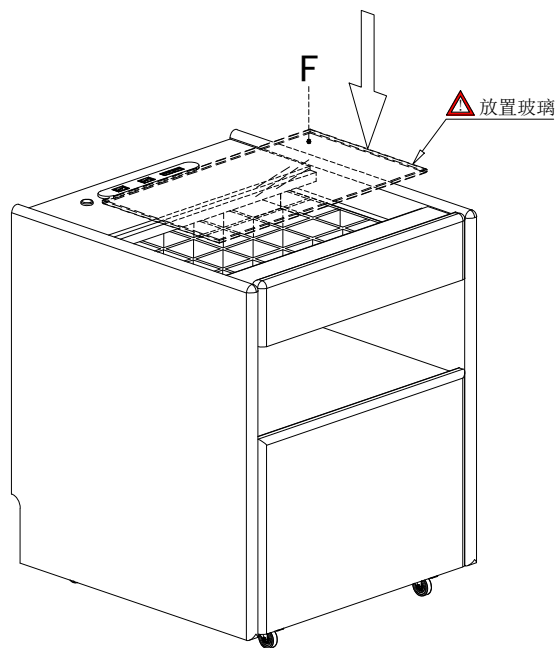

步骤18

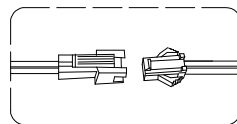
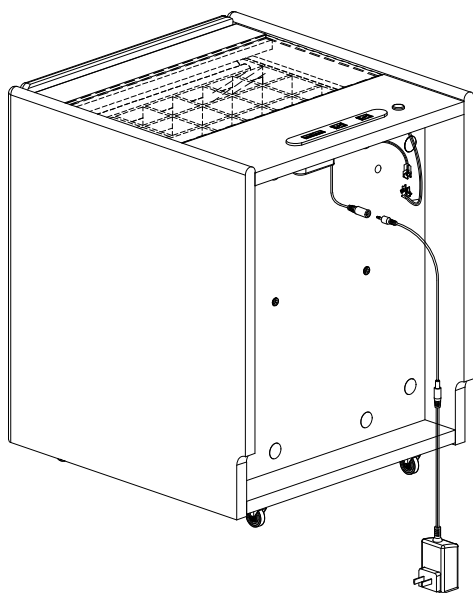

图一

将灯带电线接口与控制开关接口如图连接好

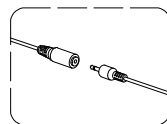

图二

将控制开关与（电源器）连接好