

OUTDOOR LED POST LANTERN

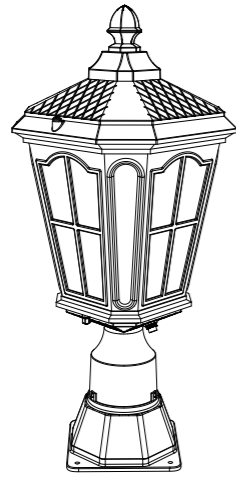

IMPORTANT INFORMATION. PLEASE READ CAREFULLY AND RETAIN FOR FUTURE REFERENCE

This product is suitable for use in outdoor environments. The light has the following features:

- Cast aluminum body and glass lens.
- Dusk-to-Dawn photocell sensor which automatically turns the light on at night, and off during the day. (To override the sensor, place the included light sensor cap over the photocell eye.)
- 8-watt LED bulb is included. Produces 800 lumens and 3000K light color. (Medium base E26 socket will also accept up to 60 watt incandescent lamps, by other.)
- Bottom opening accepts 3" O.D. round pipe or post.

Important Safety Instructions:

Please read the following safety information before use. To reduce risk of fire, electric shock, or injury to persons:

- **CAUTION:** Turn OFF the main power at the fuse or circuit breaker before installing the light fixture or making any electrical connection. You may use a non-contact voltage tester to ensure no power is running to the wires.
- **CAUTION:** Risk of fire. Min. 90° C supply conductors. Consult a qualified electrician to ensure correct branch circuit conductor.
- **WARNING:** If any special control devices are used with this fixture, follow instructions carefully to ensure full compliance with N.E.C. requirements. If there are any questions, contact a qualified electrical contractor.
- Make sure this light fixture is adequately grounded. To ensure proper grounding, there must be a separate ground wire (bare copper) contact between this light fixture and the ground connection of your main power supply panel. Do not connect the bare or green insulation fixture ground wire to the black (hot) current-carrying wire or the white (neutral) wire. Connection of the bare or green fixture ground to the black or white wires may cause metal parts of the fixture to carry electrical currents, and may cause electrical shock, which could cause serious injury or death.
- Do not connect this fixture to an electrical system that does not provide a means for equipment grounding. Never use a fixture in a two-wire system that is not grounded. Installing a fixture into an electrical system not having a proper grounding could cause metal parts of the fixture to carry electrical currents if any of the fixture wires, wire connections, or splices were to become broken, cut, or loose during the mounting or normal operation of the fixture. Under this condition, anyone coming in contact with the fixture would be subject to electrical shock, which could cause serious injury or death.
- **CAUTION:** A loose wire increases the risk of fire; tighten all connections securely.
- Do not suspend any fixtures by the house wires. Suspending a fixture by the house wires and wire connectors may result in the fixture falling, possibly causing personal injury and the danger of electrical shock or fire.
- The luminaire must be installed by qualified electrician. All electrical connections must be in accordance with all national and local electrical codes.
- This light fixture is designed for use in 120VAC, 60Hz fuse circuit. Not for use on a dimming circuit.
- **CAUTION:** All glass is fragile. Use care when handling glass shades and bulbs.
- For outdoor use.











2

Warning:



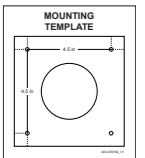

- Failure to disconnect the power supply prior to installation may result in serious injury or death.
- The warnings, precautions, and instructions discussed in this manual cannot cover all possible conditions and situations that may occur. The operator must understand that common sense and caution are factors which cannot be built into this product, but must be supplied by the operator.

PACKAGE CONTAINS:

Please lay out all parts and read the instructions prior to installation.

 1 x Lantern Cover	 4 x Wood Screws	 4 x Drywall Screws	 4 x Anchors
 1 x Outdoor LED Post Lantern Body	 3 x Wire Nuts	 3 x Set Screws	 1 x Mounting Template
 1 x Mounting Base	 2 x Thumb Screws	 1 x Light Sensor Cap	
 1 x 8W LED Bulb (E26 Base)			

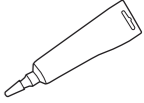
Tools Needed (not included):

-  #2 Phillips Head Screwdriver
-  Power Drill
Drill bit size: 1/16 in
-  Silicone Sealant
-  Safety Glasses

3

BEFORE INSTALLATION:

- Carefully remove the Post Lantern fixture, LED bulb and mounting accessories from the box, and check that all parts are included. Do not attempt to assemble the product if any part(s) is missing or damaged. If so, please contact our customer support.
- The outlet box described in this manual is not provided. A standard outlet box needs to be pre-installed in the mounting surface. Power supply wires running to the outlet box must be rated 120VAC. If an outlet box does not exist, contact a qualified electrician for installation.
- Turn OFF the main power at the fuse or circuit breaker before installing the light fixture or making any electrical connection. You may use a non-contact voltage tester to ensure no power is running to the wires.

Warning: Failure to disconnect the power supply prior to installation may result in serious injury or death.
Never connect the ground wire to the hot or neutral power supply wires.

THIS PRODUCT MUST BE INSTALLED IN ACCORDANCE WITH THE APPLICABLE INSTALLATION CODE BY A PERSON FAMILIAR WITH THE CONSTRUCTION AND OPERATION OF THE PRODUCT AND THE HAZARDS INVOLVED

INSTALLATION:

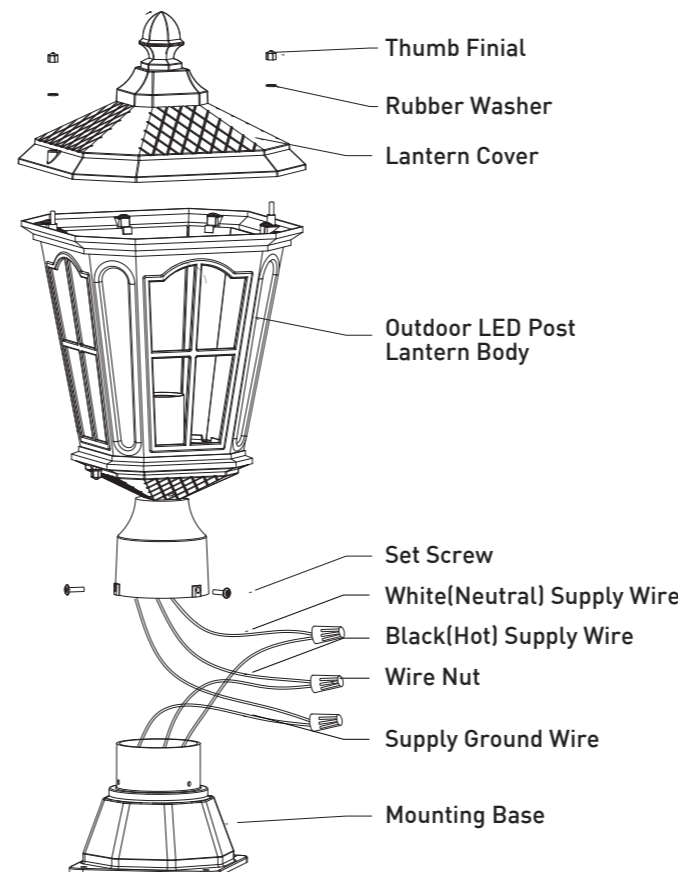

INSTALLATION PROCEDURE:

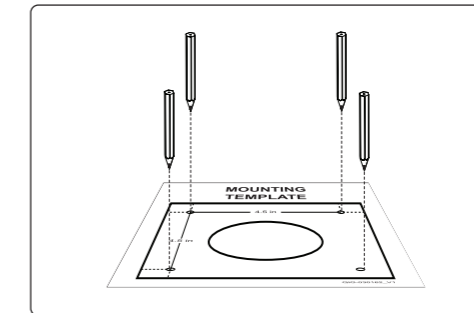

1. Select a mounting location suitable for supporting the light. Use the measuring template to mark the screw locations on the mounting surface.

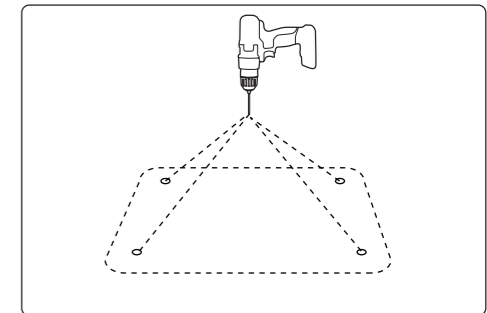

2. Wear safety glasses before drilling pilot holes. Drill two 2 mm diameter pilot holes.

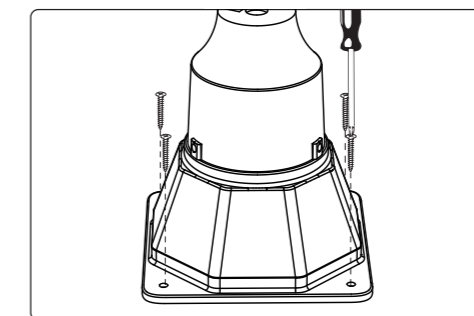

3. Screw the mounting base onto mounting surface. For installation on wood, please use wood screws. For installation on brick or concrete, please use plastic anchor and drywall screws.

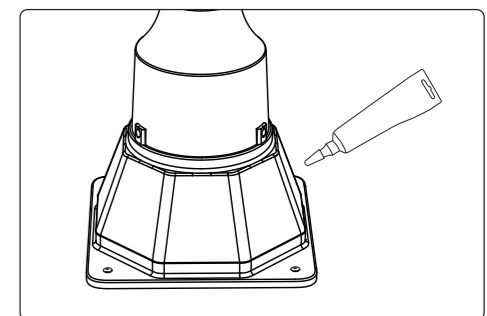

4. To prevent moisture from entering the mounting base, caulk the base to the mounting surface with silicone sealant (not included). The sealing compound should fully fill the gap of mounting base and mounting surface.

4

5

6

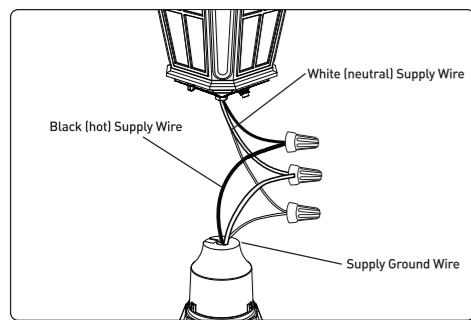

5. Make the following spliced wire connections using wire nuts:

Black (hot) wire to the hot supply wire (most likely black or colored).

White (neutral) wire to the neutral supply wire (most likely white).

Bare copper (ground) wire to the supply ground wire (most likely bare copper, green wire, or green and yellow wire), or wrap around the ground screw if ground wire does not exist. Never connect ground wire to black or white supply wires.

Screw the wire nuts in a clockwise direction until tight. Make sure no bare wire or wire strands are visible after making the connections. Check for tightness by pulling wires.

Consult with a qualified electrician if you have any electrical questions or if your current power supply does not include a ground wire.

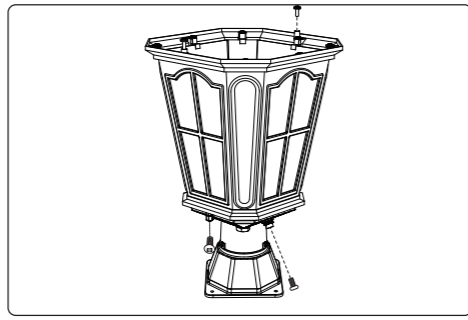

6. Carefully place all the wires and wire connections into the base. Attach the light to the mounting base, and ensure the orientation of the light is correct, with the light sensor facing front. Secure the light to the mounting base with set screws.

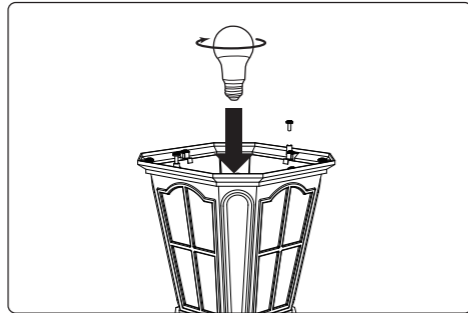

7. Insert the light bulb.

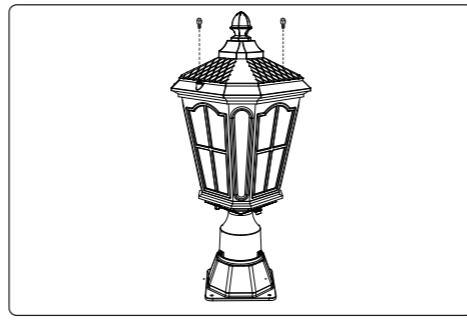

8. Close the lantern cover and secure with thumb screws.

INSTALL ON POST

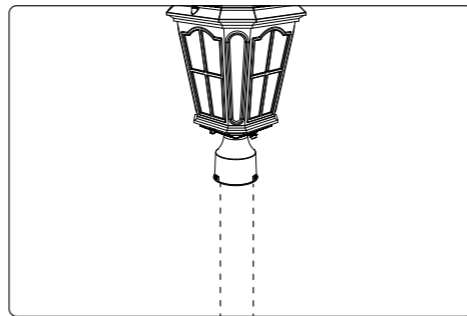

The post lantern can be installed on commercially available 3" round post (not included). Repeat Step 5 thru 9 for installation. Ensure installation is in accordance with NEC and local building code specifications. If not familiar with these codes, consult a certified electrician.

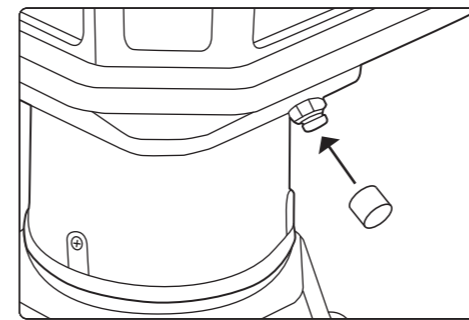

9. (Optional) To turn on the light during the day, place the Cap over the light sensor to disable the dusk-to-dawn feature.

REPLACING LED OR INCANDESCENT BULBS

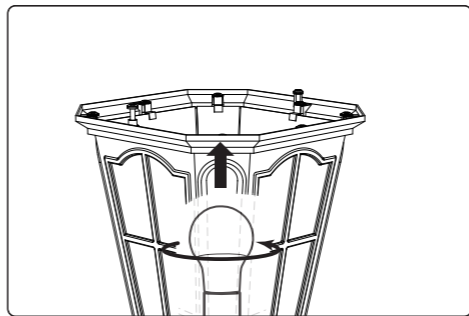

Unscrew to open top cover of post light, and remove the existing light bulb. Only replace light bulb with E26 base, 120 V, 60 W maximum.

LIGHT SENSOR CAP

If you wish to override the dusk-to-dawn photocell sensor (ex: to turn lights ON during the day), use the included light sensor cap. Refer to Installation Step 8 on page 8.

PRODUCT SPECIFICATIONS:

Operating Voltage: 120 Vac, 60 Hz
 Compatible with an incandescent light bulb of 120 V, 60 W MAX, E26 base
 LED Bulb (included): 800 lumen, 3000K, 8 W (not to use with dimmer)

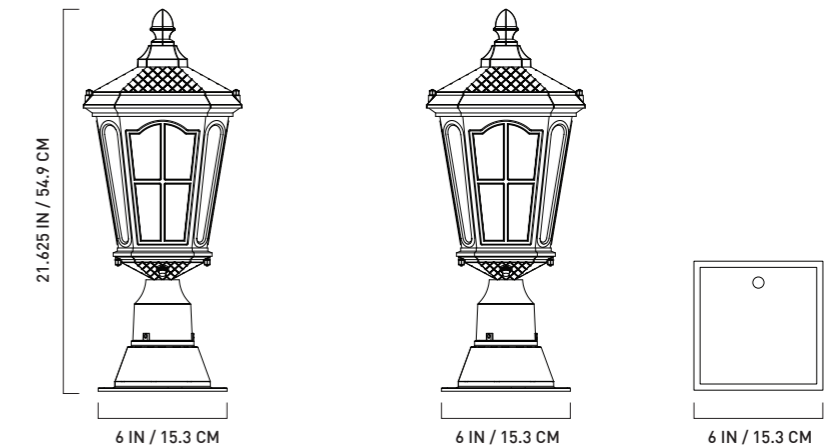

TROUBLESHOOTING:

Problem	Possible Cause	Solution
The light does not come on.	During the day the dusk-to-dawn feature keeps the light off.	Place the Cap over the light sensor as shown in step 9 (refer to Installation Step 9 on page 8).
	The light wall switch is turned off.	Turn the light wall switch on.
	The fuse is blown or the circuit breaker is turned off.	Replace the fuse or ensure the circuit breaker is turned on.
	Faulty wire connection.	Check all wiring to ensure they are correctly and securely wired.
The light does not come on during night.	Other light sources, such as other light fixture or street light, is shining onto the photosensor.	Move the light fixture away from offending light sources.
The light stays on through the day	Photosensor is blocked or covered; or fixture is located in extremely shadowed area during the day.	Remove sensor cap or any debris blocking the sensor. If in extreme shadow area, move fixture to a location with more sunlight.

Important Safety Instructions:

Warranty:

This product carries a 5-year warranty against defects in workmanship and materials subject to the conditions and additional warranty information

DISCLAIMER OF WARRANTIES, INCLUDING WARRANTY OF MERCHANTABILITY AND WARRANTY OF FITNESS FOR PARTICULAR PURPOSE: EXCEPT AS SPECIFICALLY SET FORTH HEREIN, NO WARRANTY OR REPRESENTATION, EXPRESS OR IMPLIED, IS MADE AS TO THE LED POST LANTERN. AND/OR ITS AFFILIATES EXPRESSLY DISCLAIMS, WITHOUT LIMITATION, ANY STATUTORY WARRANTIES AND ALL IMPLIED WARRANTIES, INCLUDING ANY IMPLIED WARRANTY OF MERCHANTABILITY OR FITNESS FOR A PARTICULAR PURPOSE.