

Assembly Instruction

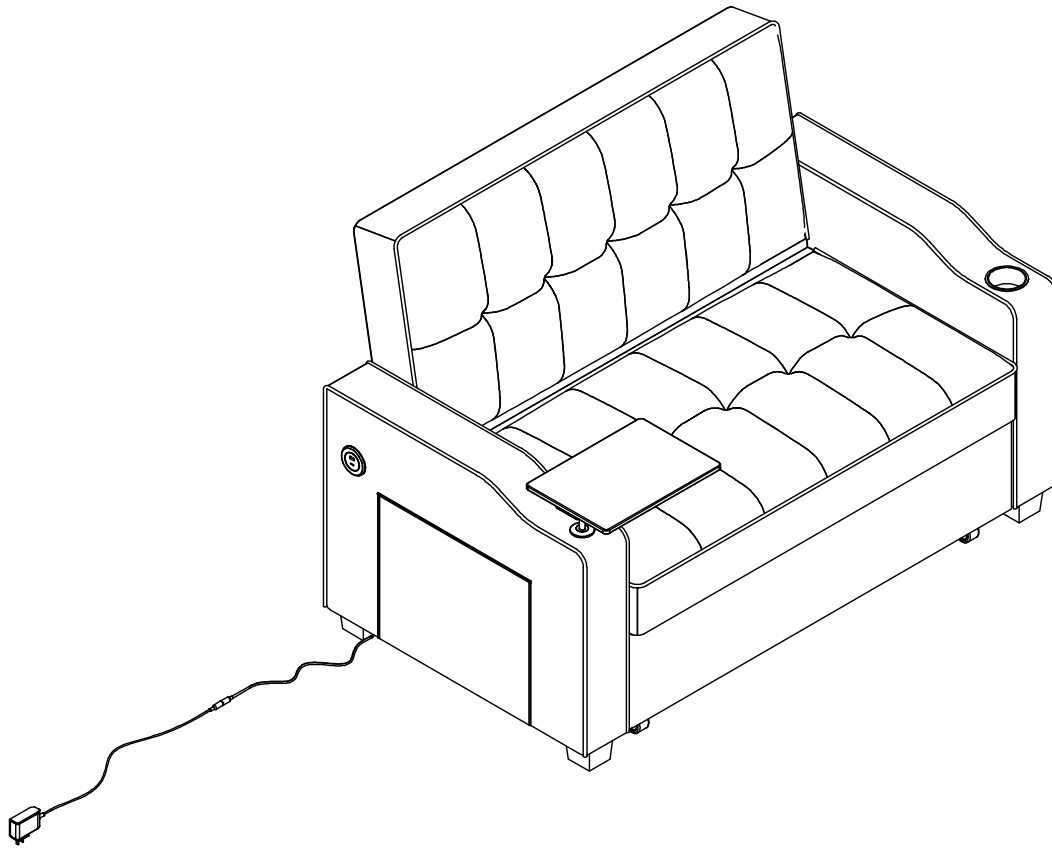

PARTS

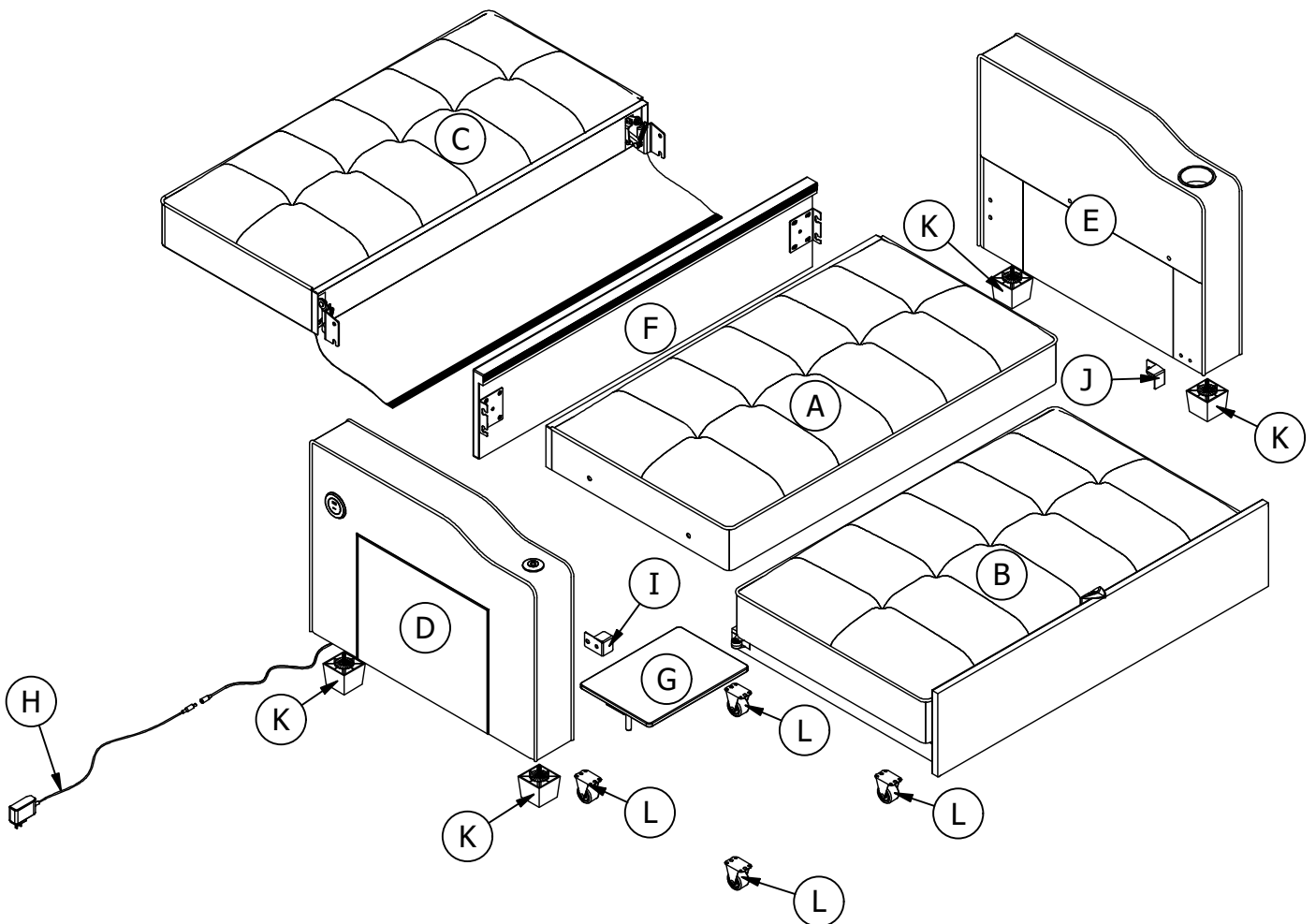

PARTS LIST

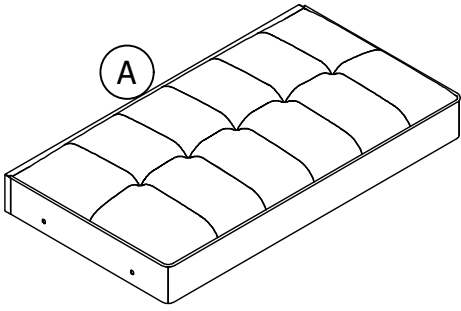

Seat X 1 PC

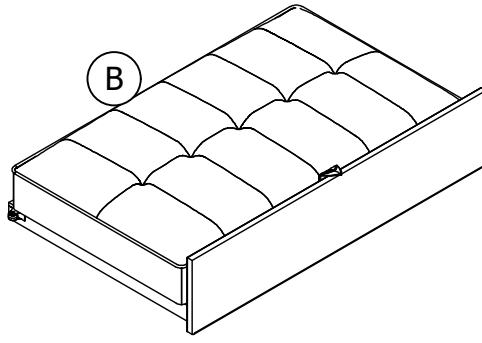

Pullout Seat X 1 PC

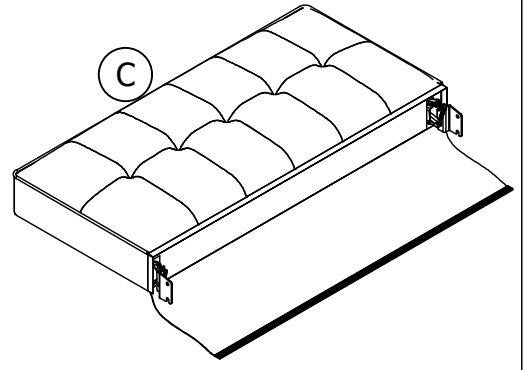

Back X 1 PC

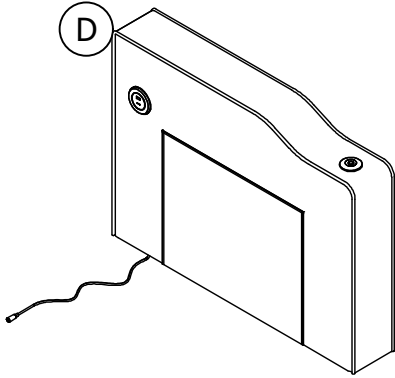

Left Armrest X 1 PC

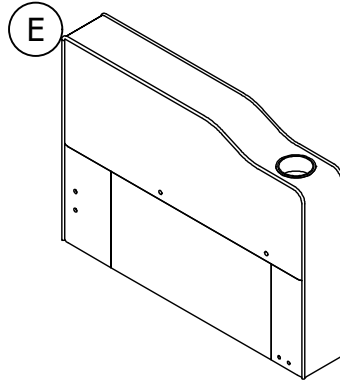

Right Armrest X 1 PC

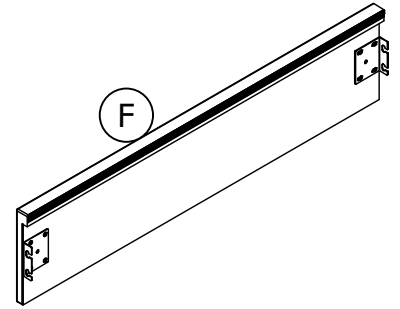

Rear Rail X 1 PC

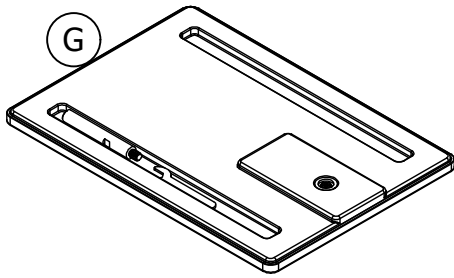

Tea Table X 1 PC

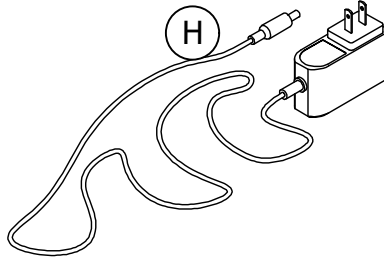

Adapter X 1 PC

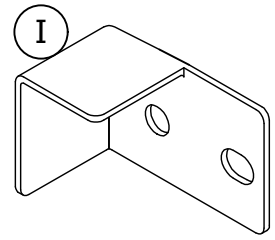

Left Bracket X 1 PC

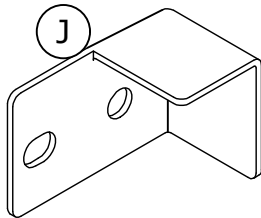

Right Bracket X 1 PC

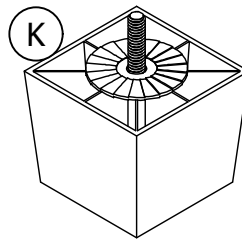

Legs X 4 PCS

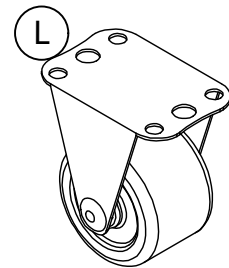

Pulley Legs X 4 PC

HARDWARE

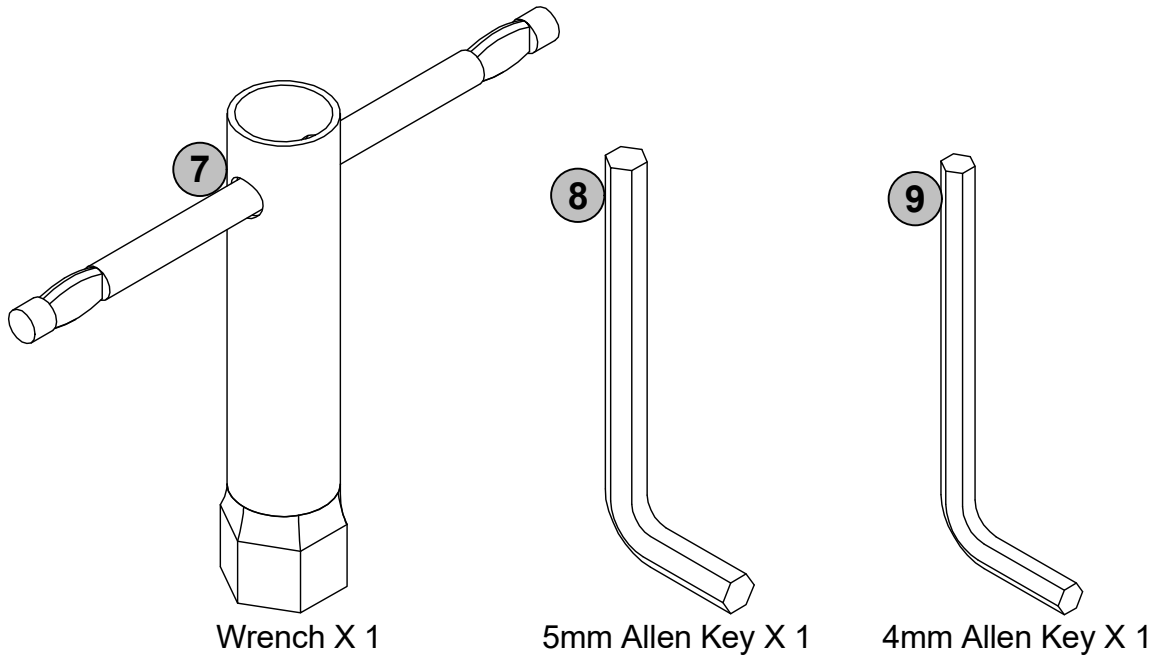
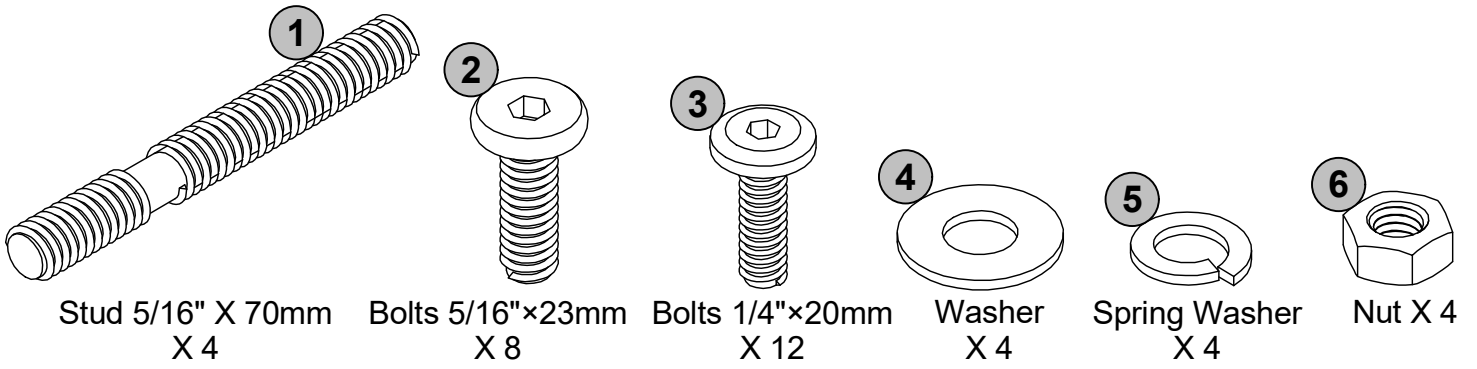

STEP 1:

Take out the tea table, bolt and wrench from the box, than hand tighten the bolt into the tea table, as shown.

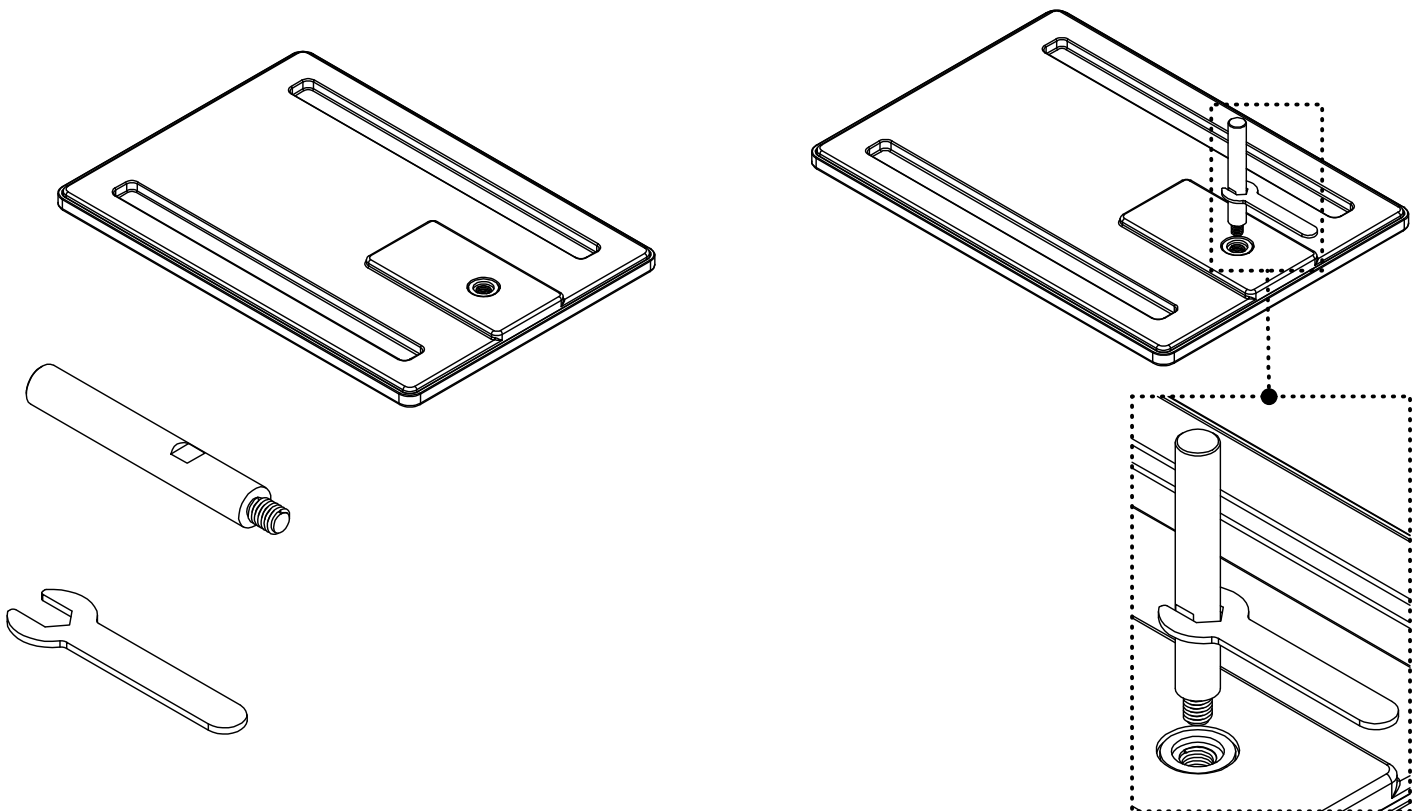

STEP 2:

Open the hook and loop fastener at both sides of seat **A**, as shown.

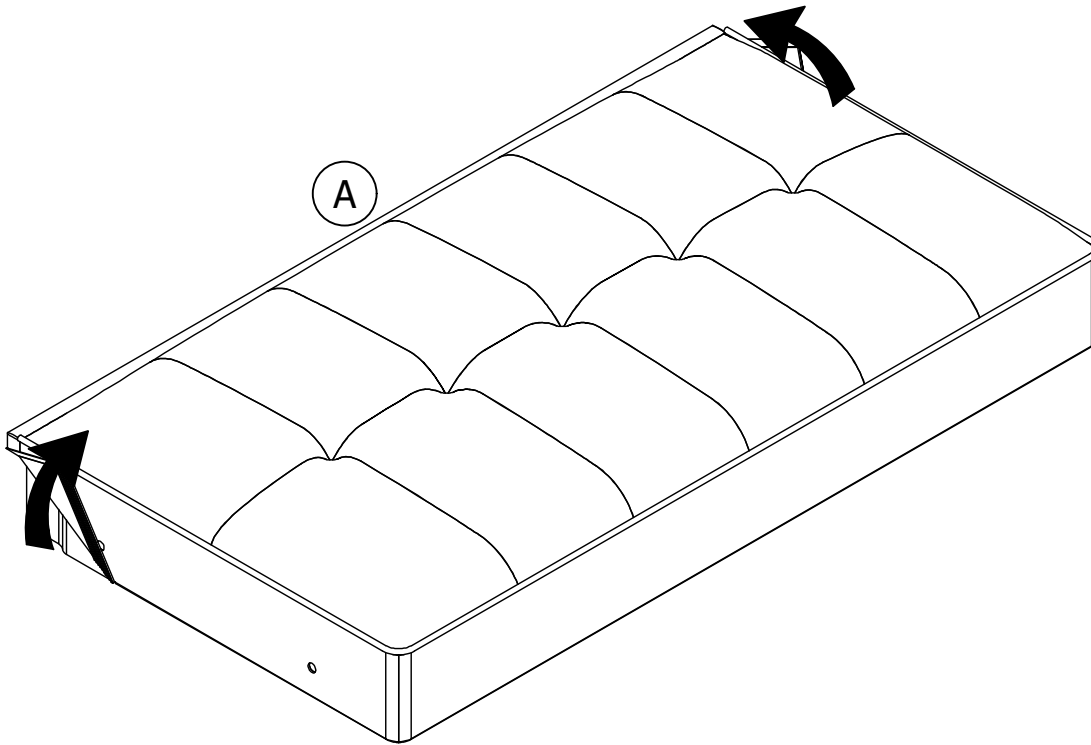

STEP 3:

Attach back **C** to seat **A** with bolt **2**, as shown.

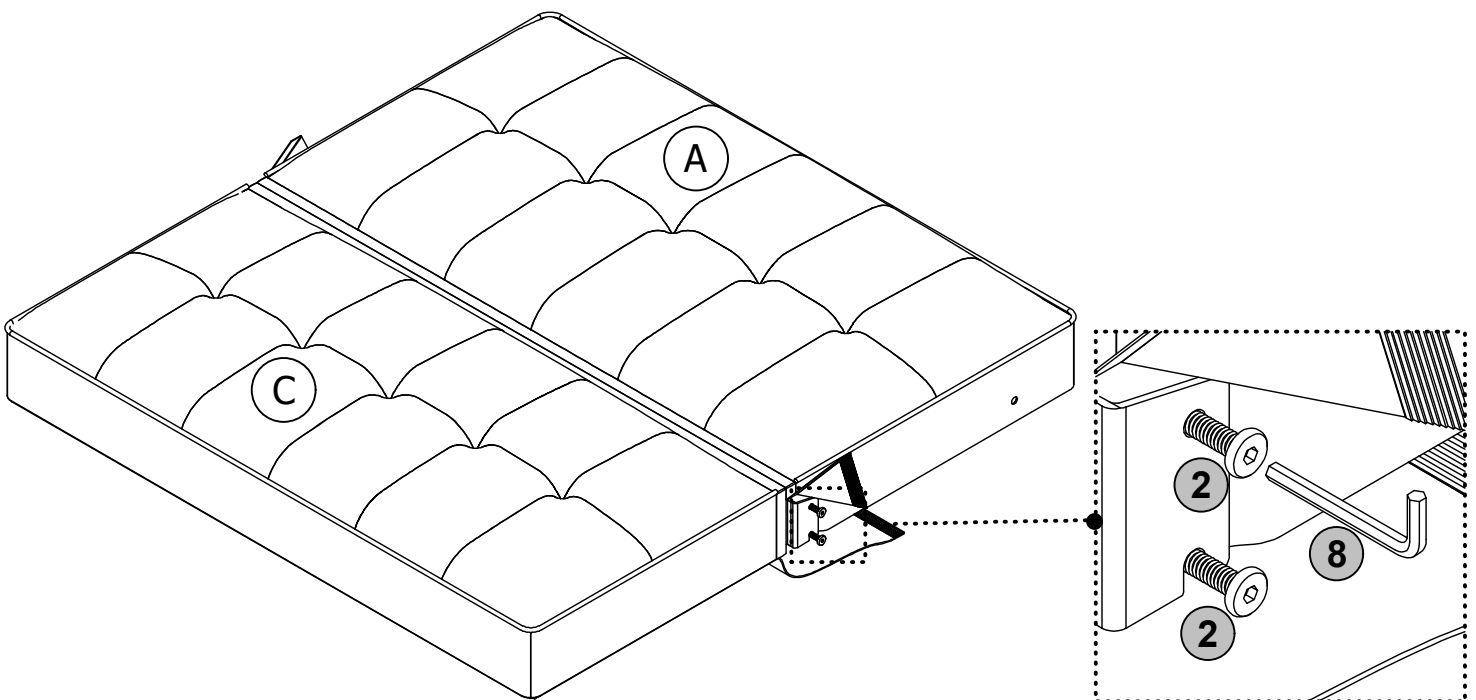

STEP 4:

4.1 Stick the hook and loop fastener at both sides of seat **A**.

4.2 Close the zipper between seat **A** and back **C**, as shown.

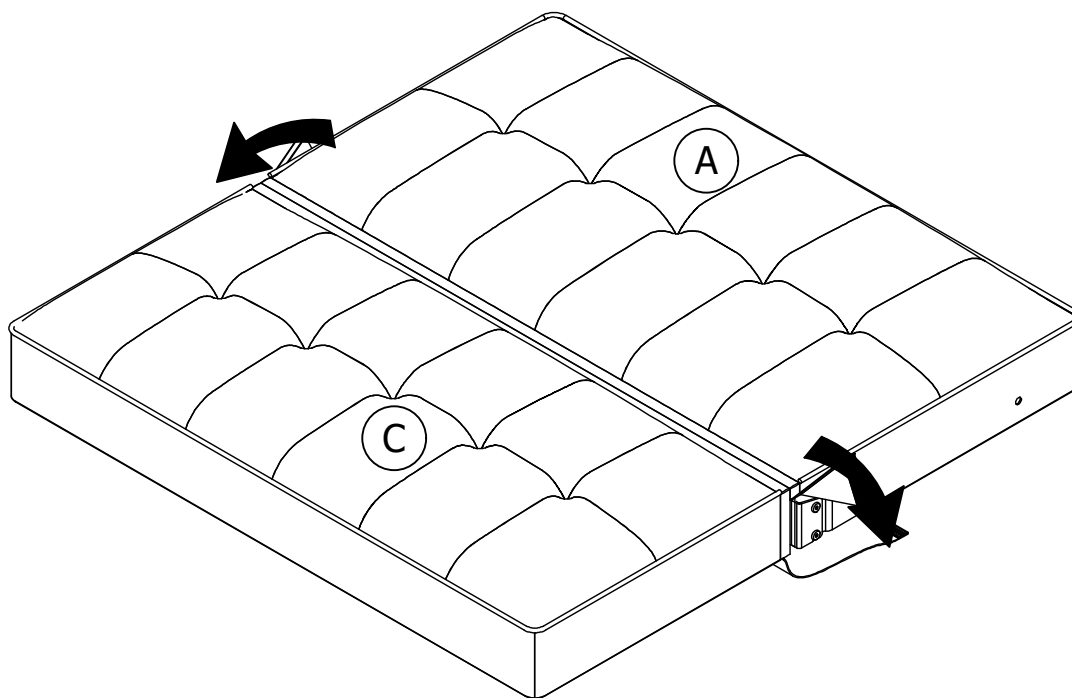

4.1

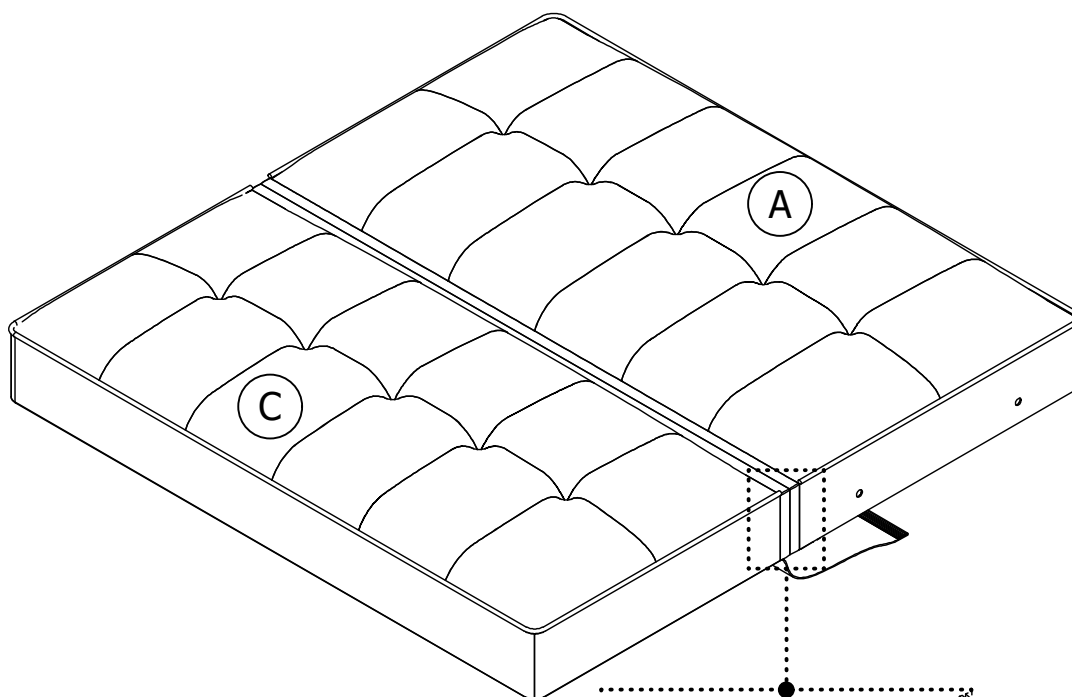

4.2

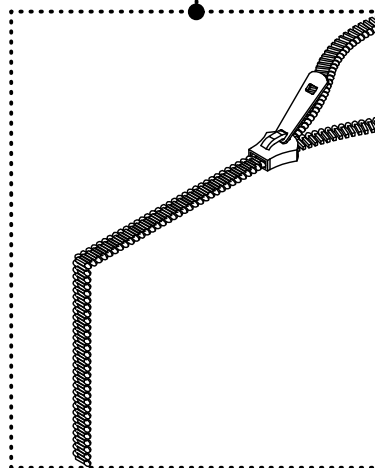

STEP 5:

Hand tighten studs **1** into Armrests **D** & **E**, as shown.

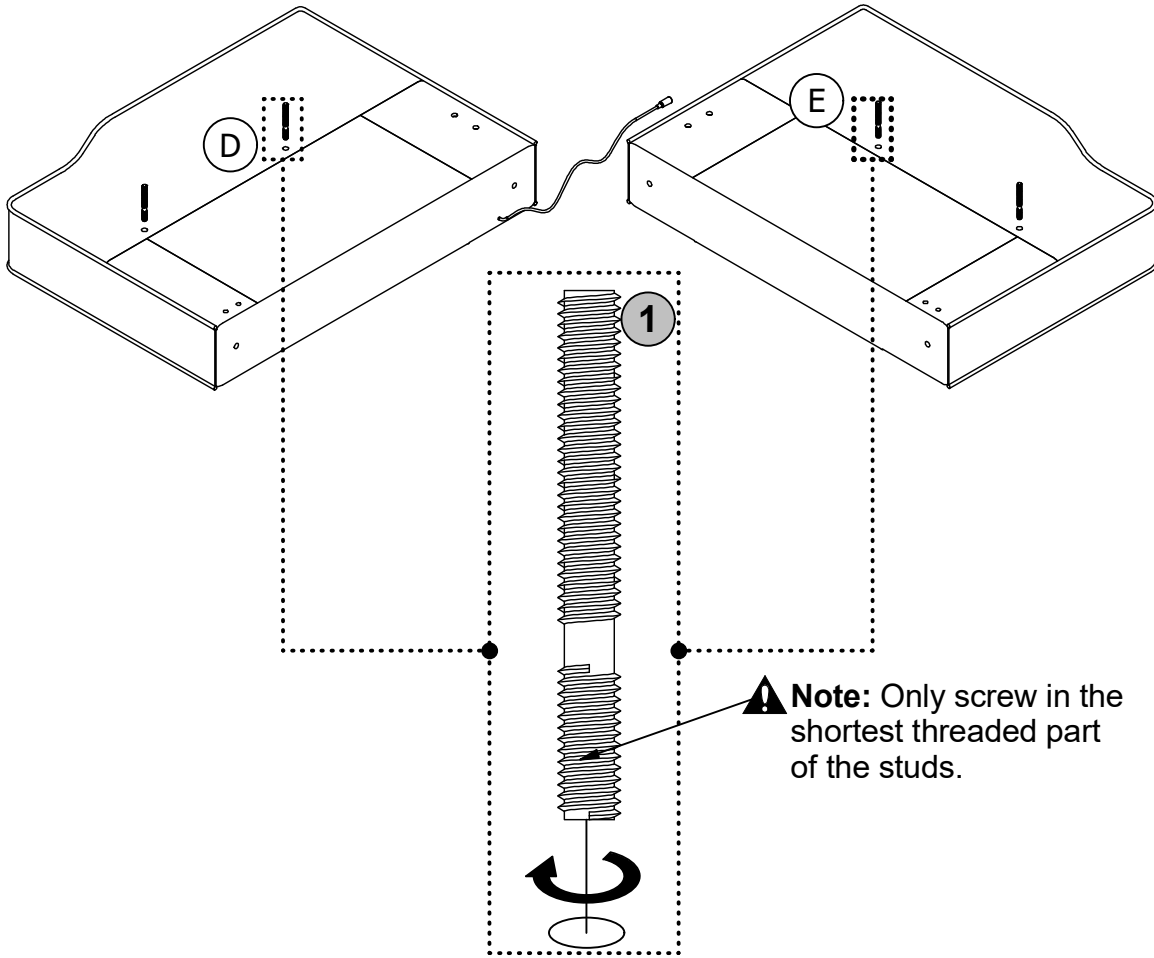

STEP 6:

Attach Bracket **I** & **J** to Armrests **D** & **E** with Bolt **3**, as shown.

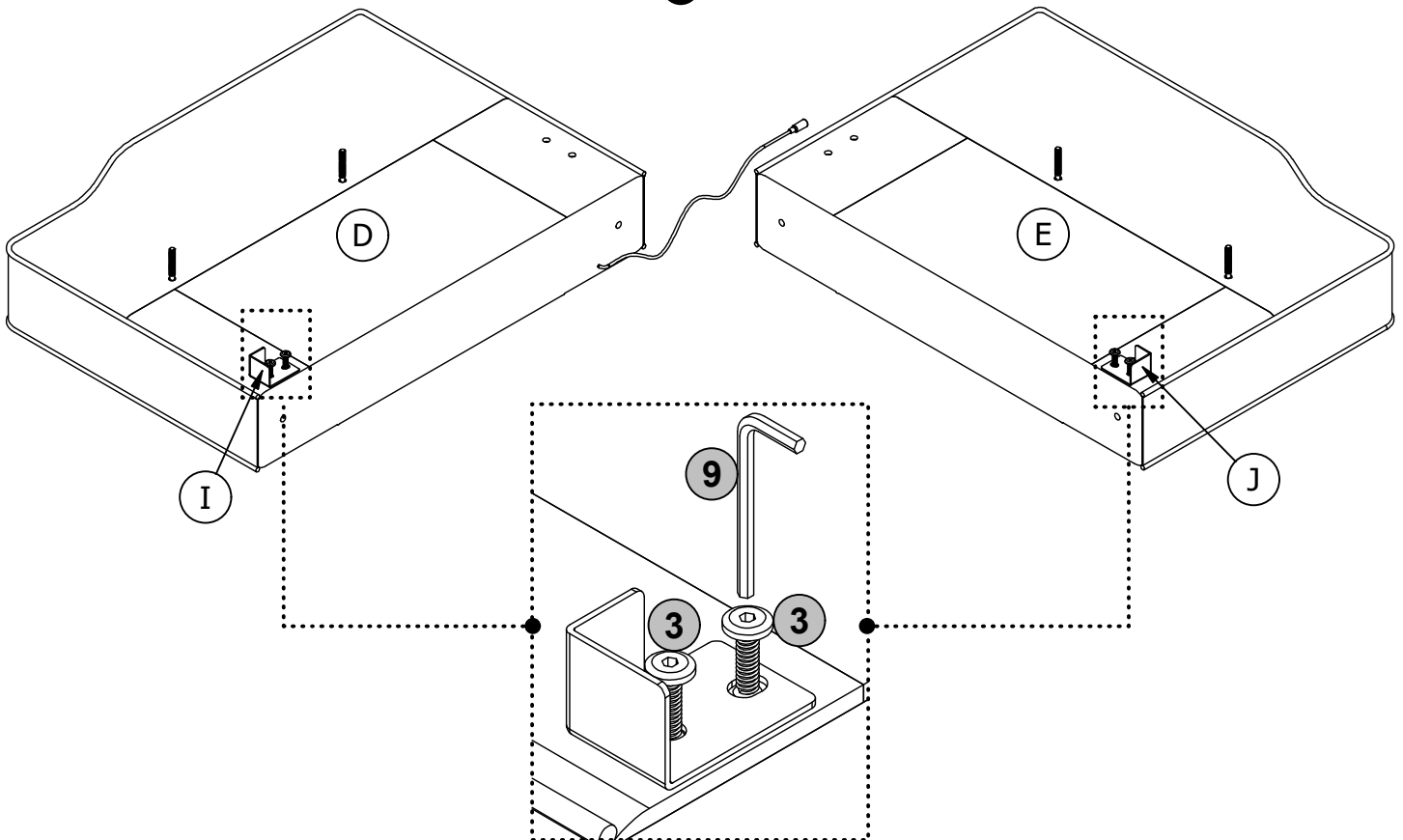

STEP 7:

Manually screw Legs **K** x 4 to Armrests **D** & **E**, as shown.

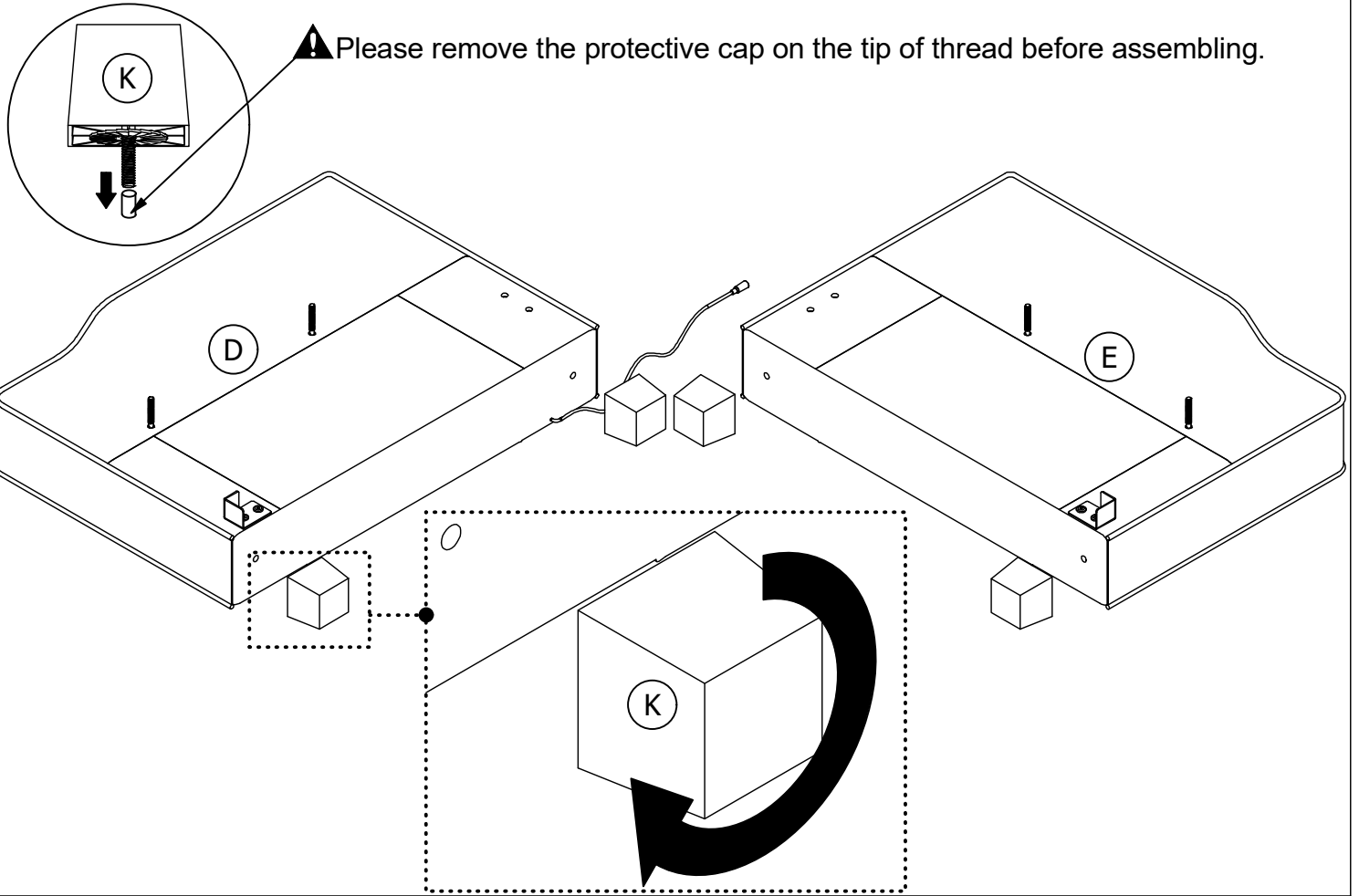

STEP 8:

Attach Armrests **D** & **E** to Seat **A** with Flat Washers **4**, Spring Washers **5** and Nuts **6**, as shown.

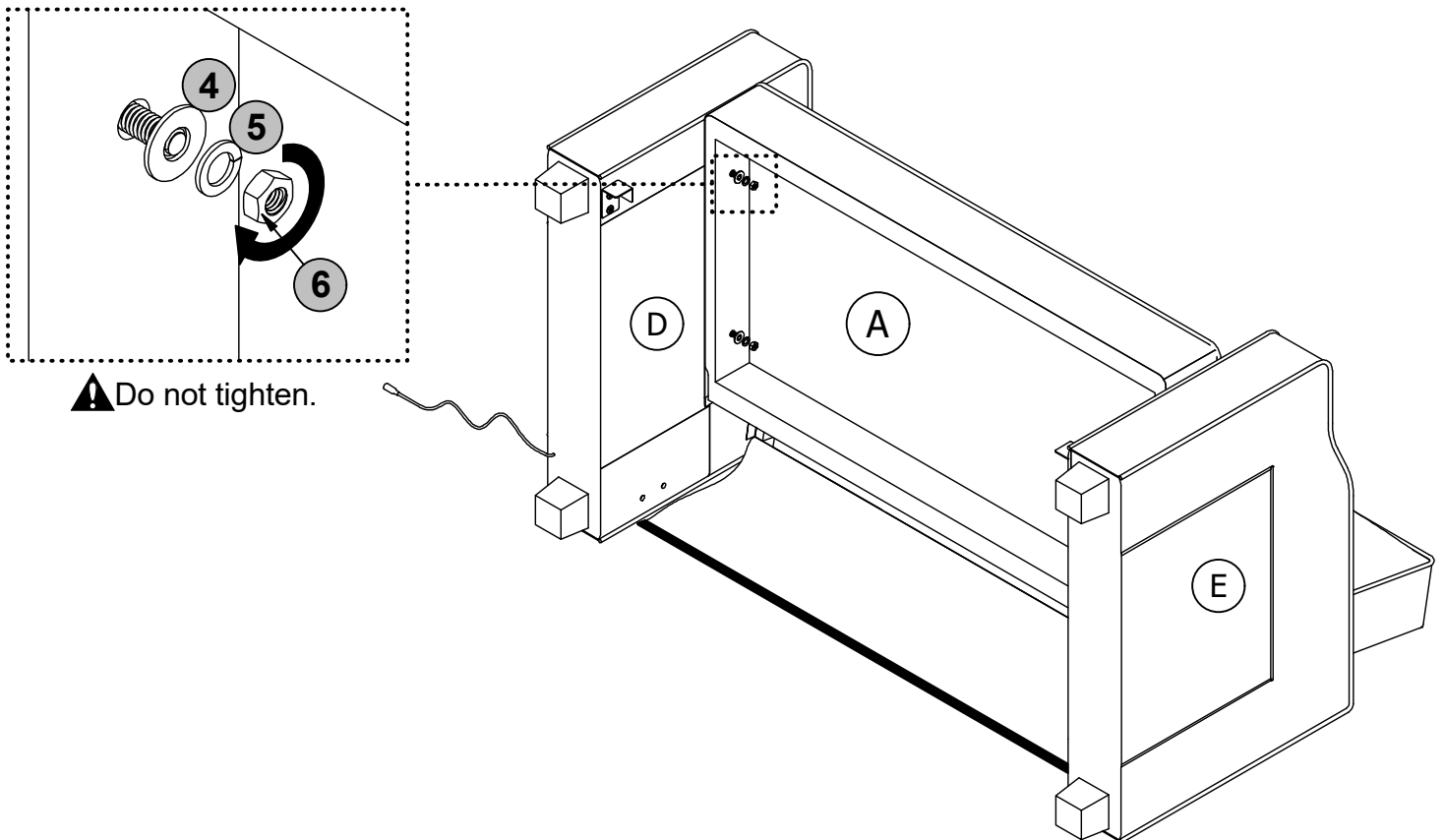

STEP 9:

Attach Rear Rail F to Armrests D & E with Bolt 2, as shown.

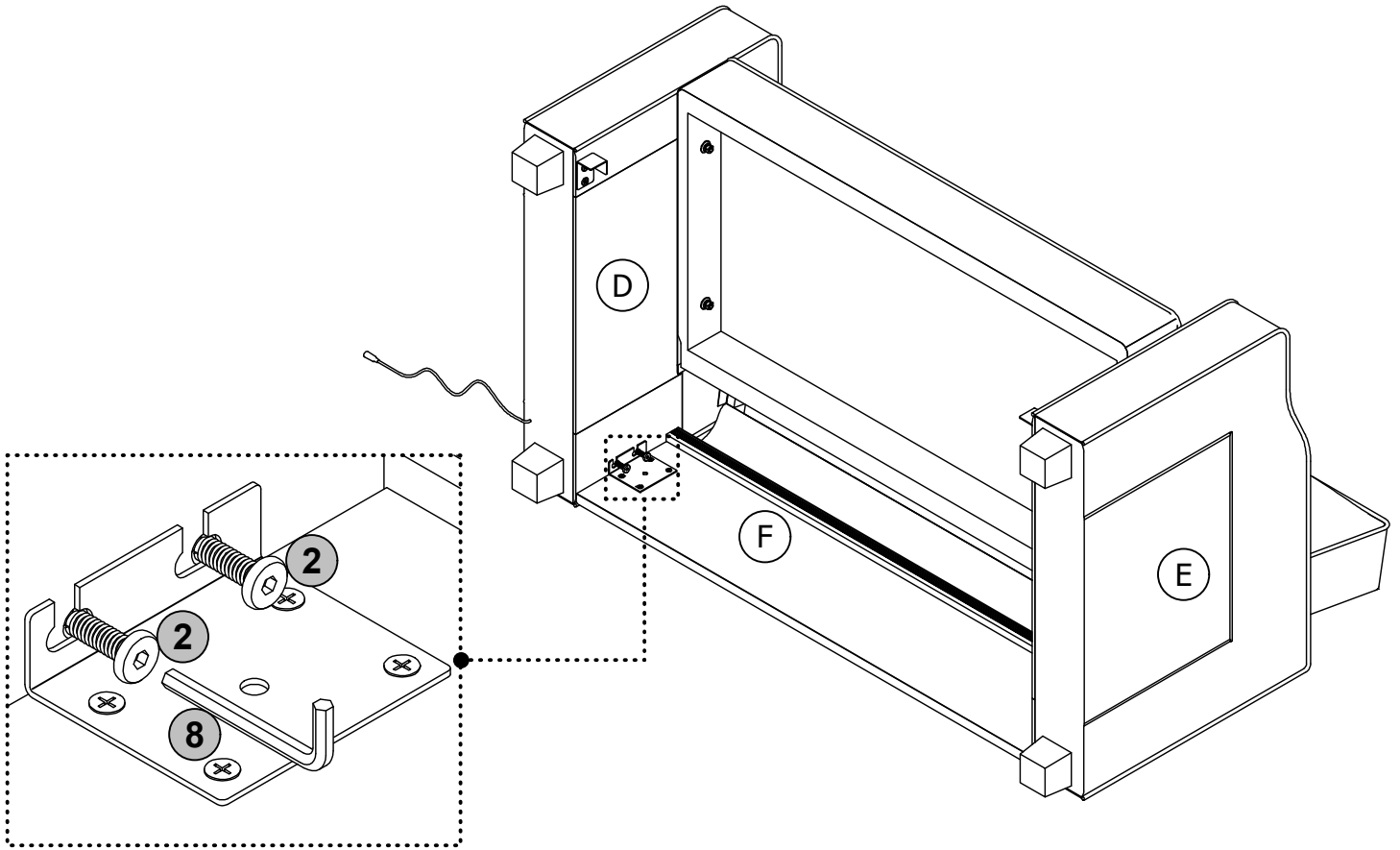

STEP 10:

Attach Armrests D & E to Seat A with Flat Washers 4, Spring Washers 5 and Nuts 6, as shown.

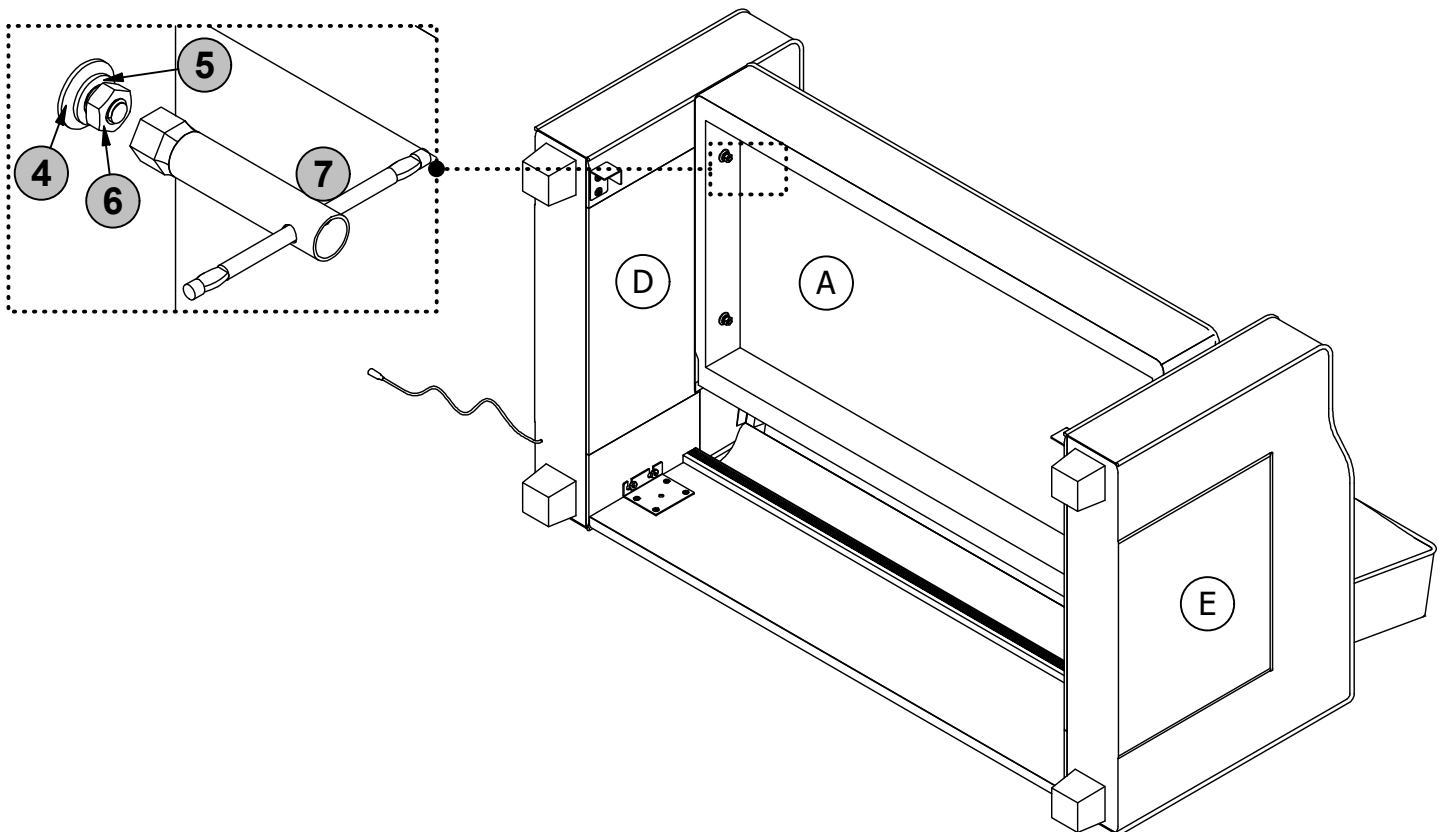

STEP 10:

Stick fabric cover on Back **C** to Rear Rail **F** with the hook and loop fastener, as shown.

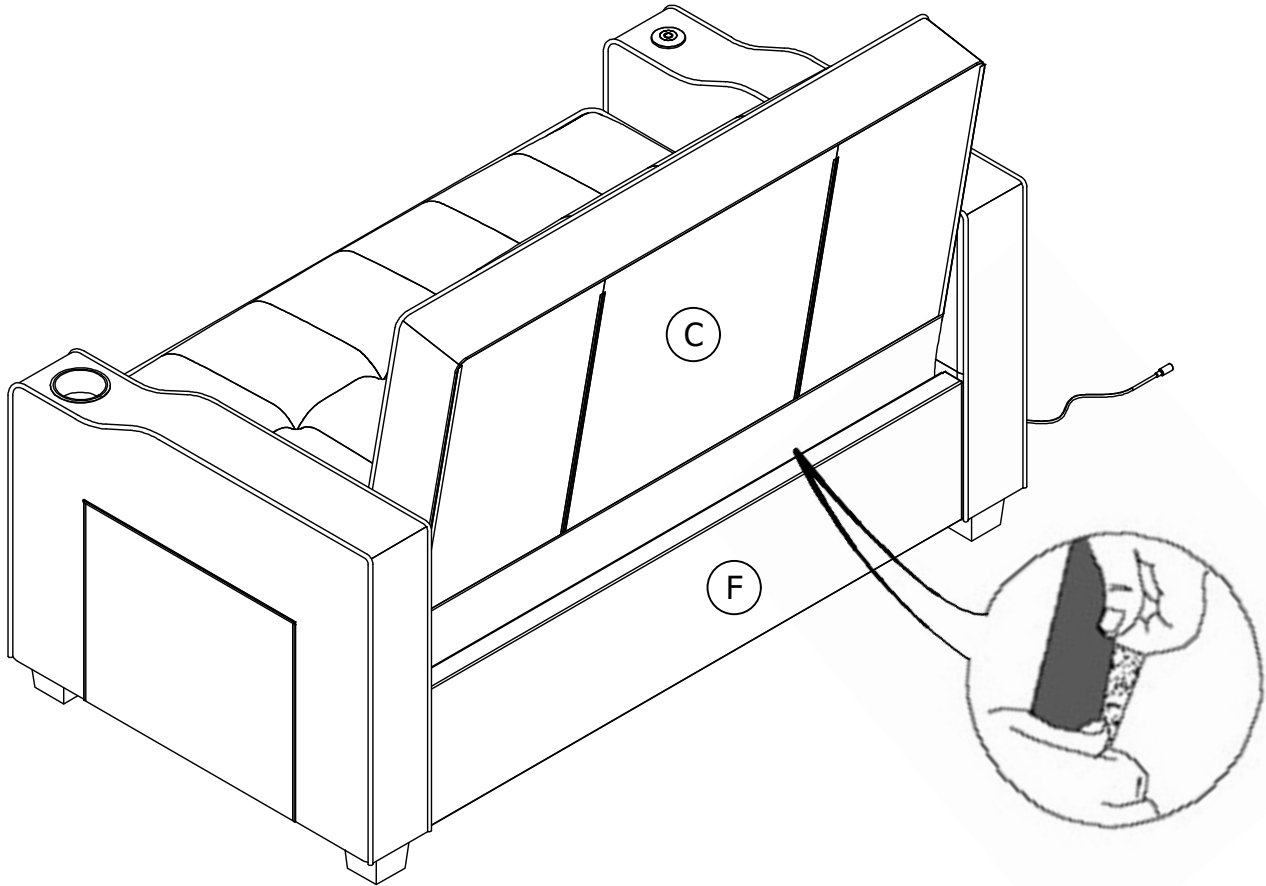

STEP 12:

Attach Pulley Legs **L** x 4 to Pullout Seat **B** with bolts **3**, as shown.

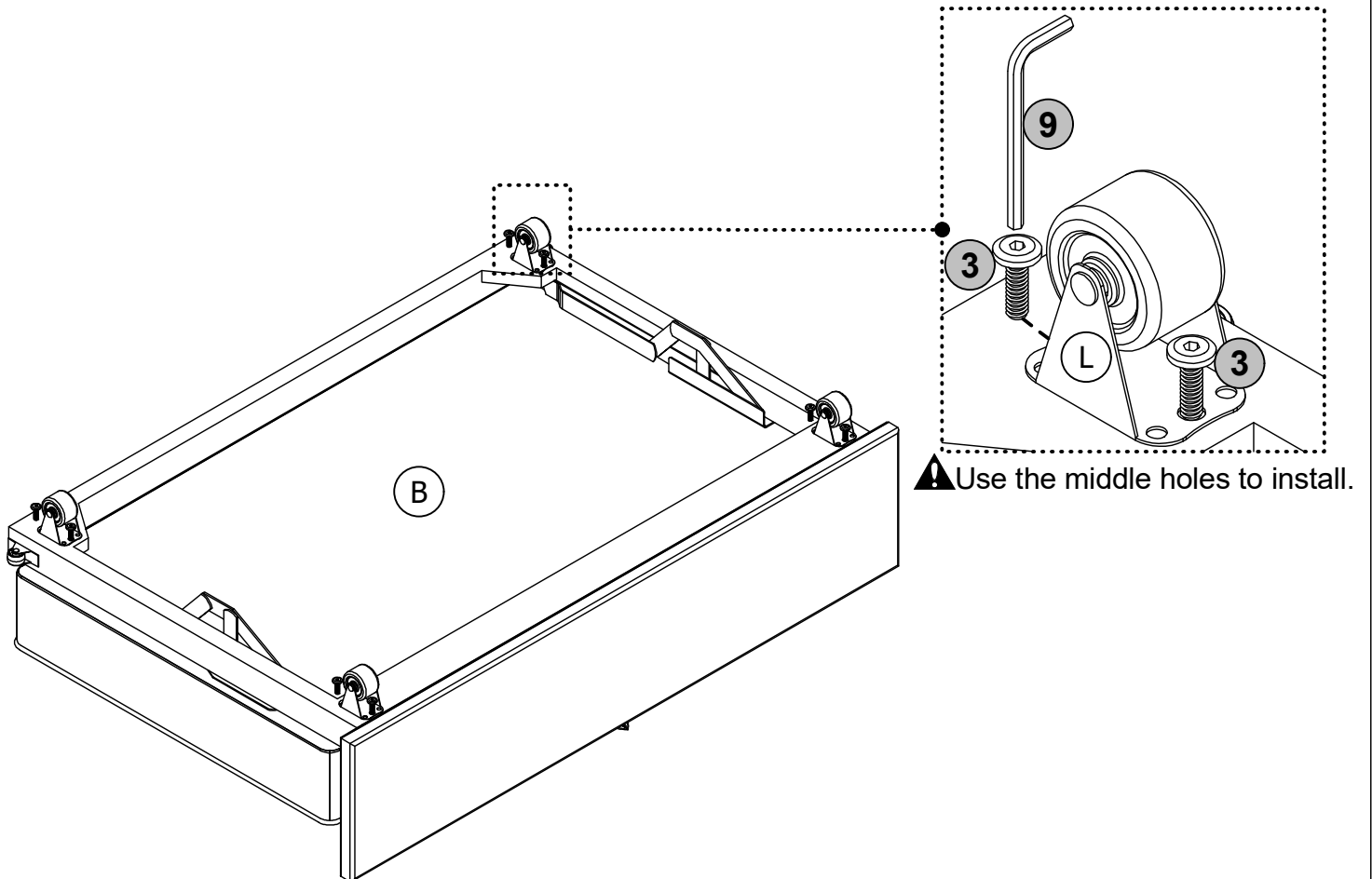

STEP 13:

Lift the end of Pullout Seat **B**, then move Pullout Seat B into Seat **A** using Bracket **I** & **J**, as shown.

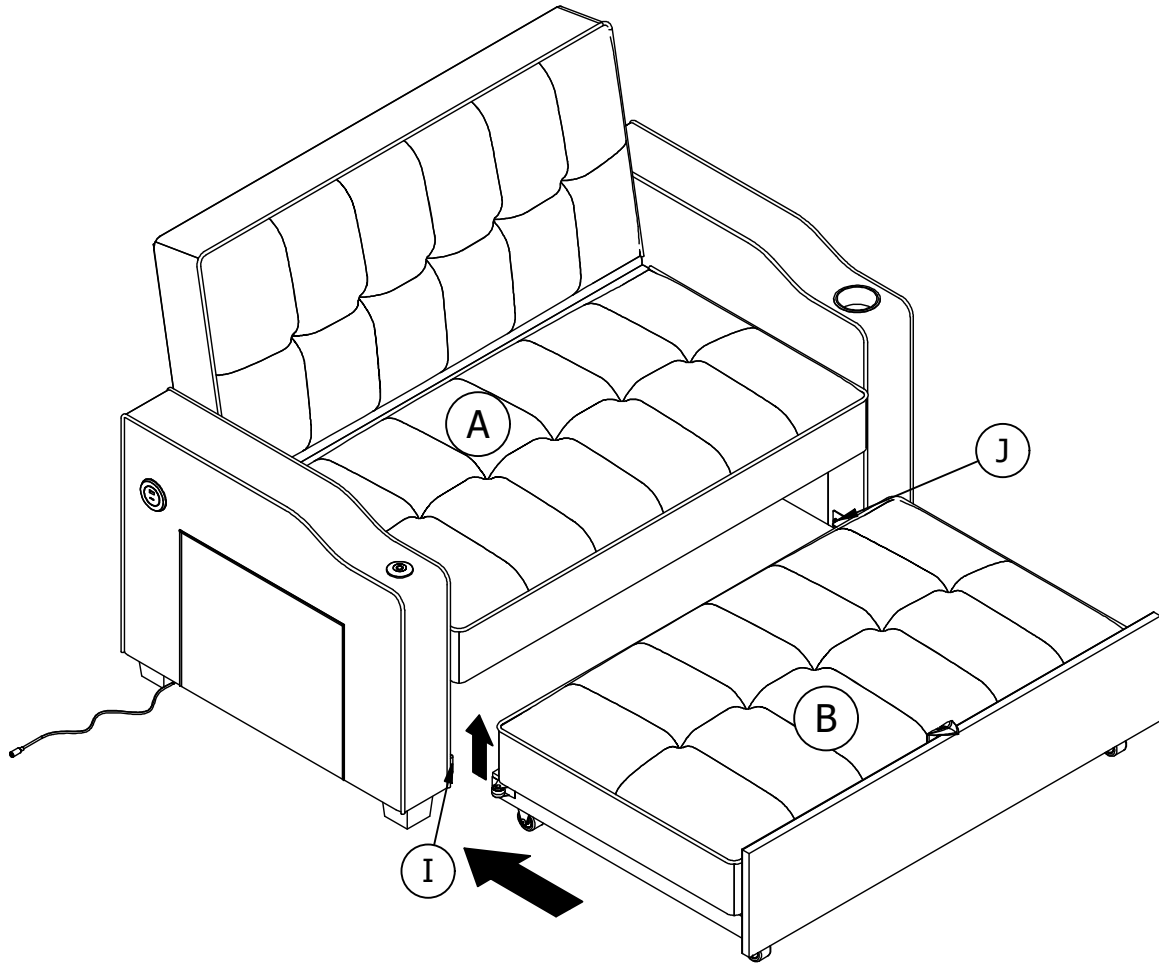

STEP 14:

Place Tea Table **G** onto the Left Armrest **D**, as shown.

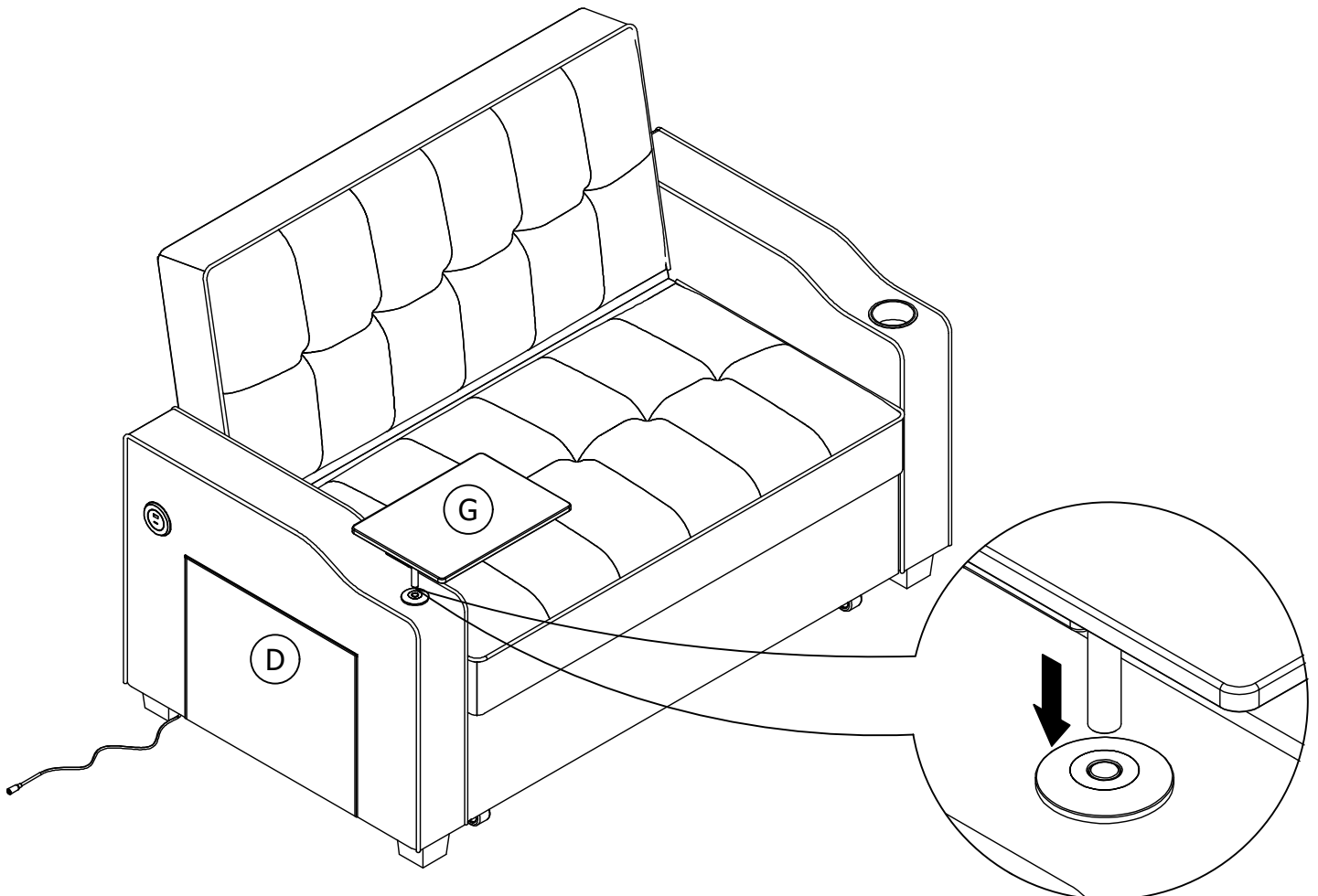

STEP 15:

Attach Adapter **H** to Left Armrest **D**, as shown.

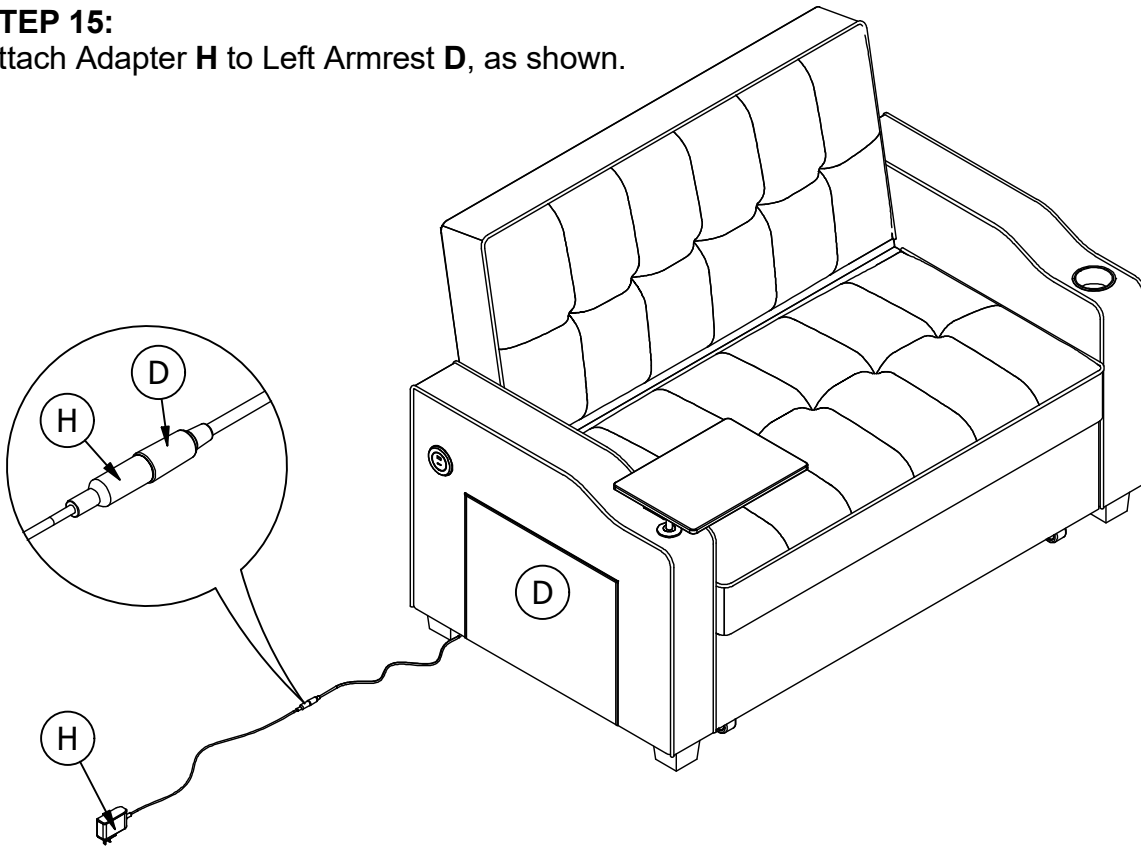

Helpful Hints

- Your futon can transform between a Sofa and a Bed.
- Move your new furniture carefully, with two people lifting and carrying the unit to its new location.
- Your furniture can be disassembled and reassembled to move.
- Clean the product with a soft damp cloth. DO NOT use harsh chemicals or abrasive cleaners.
- For further information please contact at sales4@jsanyee.com

