

Bestier 55" RGB TV Stand

Bestier 55 pouces RGB Meuble TV

Bestier 55-Zoll RGB TV-Standfuß

Mobile Bestier per TV 55" con RGB

Soporte para TV RGB Bestier de 55 pulgadas

テレビスタンドLED付き

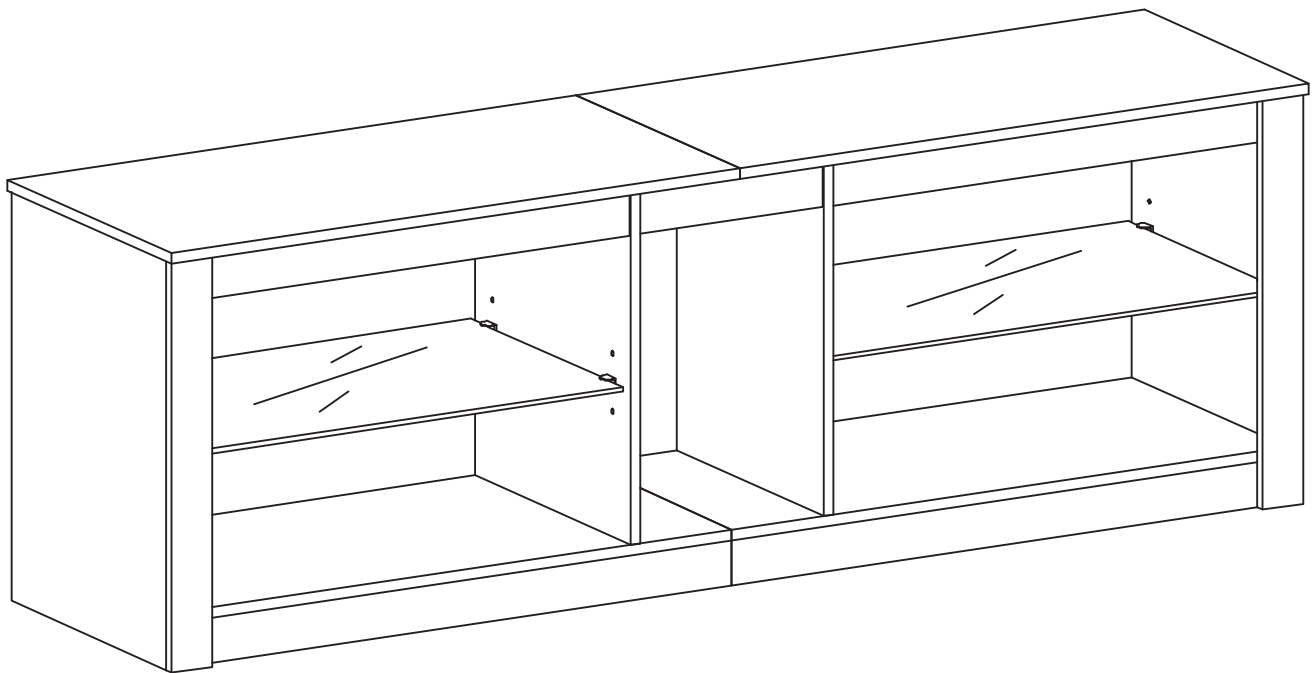

ASSEMBLY INSTRUCTION

Montageanleitung

Instructions De Montage

Istruzioni Per L'assemblaggio

Instrucciones De Montaje

組立説明書



HELPFUL HINTS

▲ BEFORE YOU START

- Inspect product packaging to ensure the appearance is good.
- Read the assembly instruction carefully and follow it step by step.
- To avoid any scratches, putting a soft blanket on the floor is suggested.
- Identify, sort and count all the parts with tags.
- Find out installation position according to the drawing and install it in correct steps.



OTHER

- People needed for assembly: 2.
- Estimated assembly time: 1-2h.

▲ CAUTION

- Be cautious when using a power drill or power screwdriver.
- Please be aware to slow down and stop when screw is nearly tight.
- Do Not use any harsh chemicals or abrasive cleaners for this item.
- Push, pull or drag this item carefully.

ASTUCES UTILES

▲ AVANT DE COMMENCER

- Inspectez l'emballage du produit pour vous assurer que l'apparence est bonne.
- Lisez attentivement les instructions de montage et suivez-les étape par étape.
- Pour éviter toute rayure, posez une couverture douce sur le sol est suggéré.
- Identifiez, trie et comptez toutes les pièces avec des étiquettes.
- Trouver la position d'installation selon le dessin et l'installer dans les étapes correctes.



AUTRE

- Personnes nécessaires pour l'assemblage : 2.
- Temps de montage estimé : 1-2h.

▲ AVERTIR

- Soyez prudent lorsque vous utilisez une perceuse électrique ou un tournevis électrique.
- Veuillez être conscient de ralentir et d'arrêter lorsque la vis est presque serrée.
- N'utilisez pas de produits chimiques corrosifs ou de nettoyeurs abrasifs pour cet article.
- Poussez, tirez ou tirez cet article avec précaution.

CONSEJOS ÚTILES

▲ ANTES DE EMPEZAR

- Inspeccione el paquete del producto para asegurarse de que la apariencia es buena.
- Lea atentamente las instrucciones de montaje y sígalas paso a paso.
- Para evitar rayas, se sugiere poner una manta suave en el suelo.
- Identifique, clasifique y enumere todas las piezas con etiquetas.
- Averigüe la posición de instalación según el dibujo e instálela en los pasos correctos.



OTROS

- Personas necesarias para el montaje: 2.
- Tiempo de montaje estimado: 1-2h.

▲ PRECAUCIÓN

- Tenga cuidado al utilizar un taladro eléctrico o un destornillador eléctrico.
- Tenga en cuenta que debe hacerlo más despacio y detenerse cuando el tornillo esté casi apretado.
- No utilice productos químicos agresivos ni limpiadores abrasivos para este artículo.
- Empuje, tire o arrastre este elemento con cuidado.

NÜTZLICHE HINWEISE

▲ BEVOR SIE BEGINNEN

- Überprüfen Sie die Produktverpackung auf Schäden.
- Lesen Sie sich die Montageanleitung sorgfältig durch und befolgen Sie sie Schritt für Schritt.
- Um etwaiges Zerkratzen zu vermeiden, wird das Auslegen einer weichen Decke auf dem Boden empfohlen.
- Identifizieren, sortieren und zählen Sie alle Teile mit Tags nach.
- Identifizieren Sie die Montageposition gemäß der Zeichnung und bauen Sie das Regal den richtigen Schritten entsprechend auf.



SONSTIGES

- Für den Zusammenbau erforderliche Anzahl an Menschen: 2.
- Ungefähre Montagedauer: 1-2h.

▲ VORSICHT

- Seien Sie bei der Verwendung einer Bohrmaschine oder eines Akkschraubers vorsichtig.
- Bitte vergessen Sie nicht darauf, langsamer zu werden und zu stoppen, sobald die Schraube fast festgezogen ist.
- Verwenden Sie keinerlei aggressive Chemikalien oder scheuernden Reinigungsmittel für dieses Produkt.
- Schieben oder ziehen Sie dieses Produkt vorsichtig.

SUGGERIMENTI UTILI

▲ PRIMA DI INIZIARE

- Controllare la confezione del prodotto per assicurarsi che sia in buono stato.
- Leggere con attenzione le istruzioni per l'assemblaggio e seguirle passo dopo passo.
- Per evitare graffi al pavimento, suggeriamo di stendervi una coperta morbida.
- Identificare, suddividere e contare tutte le parti con etichetta.
- Trovare la posizione adatta per il montaggio in base al disegno e montare lo scaffale seguendo correttamente i vari passaggi.



ALTRO

- Persone necessarie per l'assemblaggio: 2.
- Tempo di assemblaggio stimato: 1-2 ora.

▲ ATTENZIONE

- Prestare molta attenzione quando si utilizza un trapano elettrico o un cacciavite elettrico.
- Rallentare con accortezza e fermarsi quando una vite è già sufficientemente serrata.
- Non utilizzare prodotti chimici aggressivi o detergenti abrasivi su questo articolo.
- Spingere, tirare o trascinare questo articolo con cautela.

役に立つヒント

▲ 組立の場所を確保し、順番通りに組み立てる

- 組立場所（充分広くて平たい場 所）を確保してください。
- 床や壁、商品を傷つけないように、商品の下に厚めの布や段ボールなどを敷いてください。
- 組立の順番を守らないと、組立できなくなったり、商品を傷つけたりします。



その他

- 組み立てに必要な人: 2。
- 組立時間: 約1~2時間。

▲ 部品を確認する

- ネジ類などの部品番号、形状を説明書の部品一覧で確認してください。
- 部品をなくさないように纏めて置いてください。
- 部品を取り出すときに使うだけ取り出してください。

PART LIST

STÜCKLISTE
LISTE DES PIÈCES
ELENCO DEI PEZZI

LISTA DE PIEZAS
部品の確認

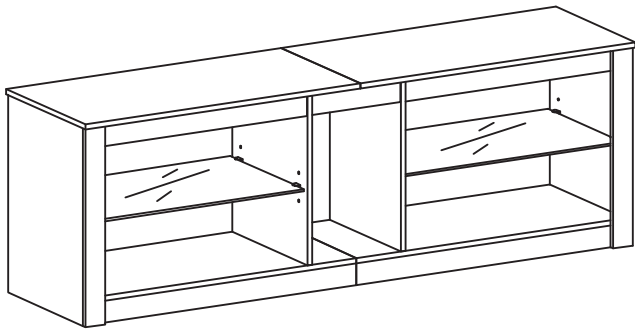

1

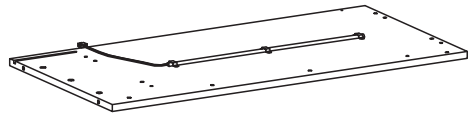

X1

2

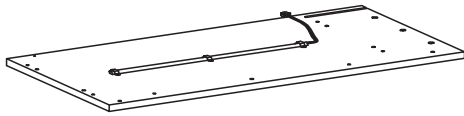

X1

3

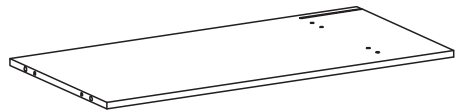

X1

4

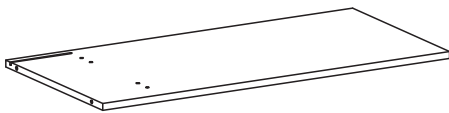

X1

5



X1

6

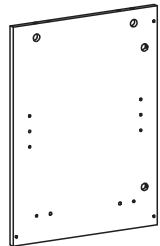

X1

7



X1

8



X1

9

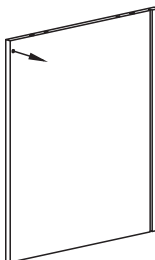

X1

10

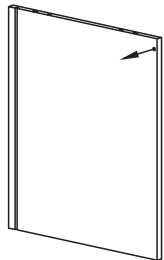

X1

11



X2

12

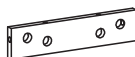

X1

13













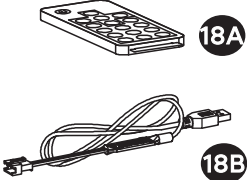



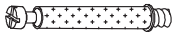





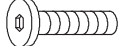

X2

14



X2

<p>15</p>  <p>X1</p>	<p>16</p>  <p>X2</p>	<p>17</p>  <p>X2</p>
	<p>18</p>  <p>X1</p>	<p>19</p>  <p>X1</p>

ACCESSORY LIST				ZUBEHÖRLISTE		LISTA DE ACCESORIOS	
				LISTE DES ACCESSOIRES		付属品部品の確認	
				ELENCO DEGLI ACCESSORI			
A		ST6x35mm	40+2	I			8
B		Ø15mm	40+2	J			2
C		Ø6x30mm	32+2	L		Ø22mm	12+1
D		ST5x40mm	4+1	K		ST3.5x12mm	4+1
E		M6x20mm	12+1	M	 M1 x1  M2 x1  M3 x2  M4 x1 ST4x38mm	2	
F		ST4x12mm	2				
G		ST3x14mm	4+1		 		
H			4+1				

DETAILS

DETAILS
DÉTAILS/POINTS DE MONTAGE
NOTE PARTICOLARI

DETALLES
組み立てのポイント

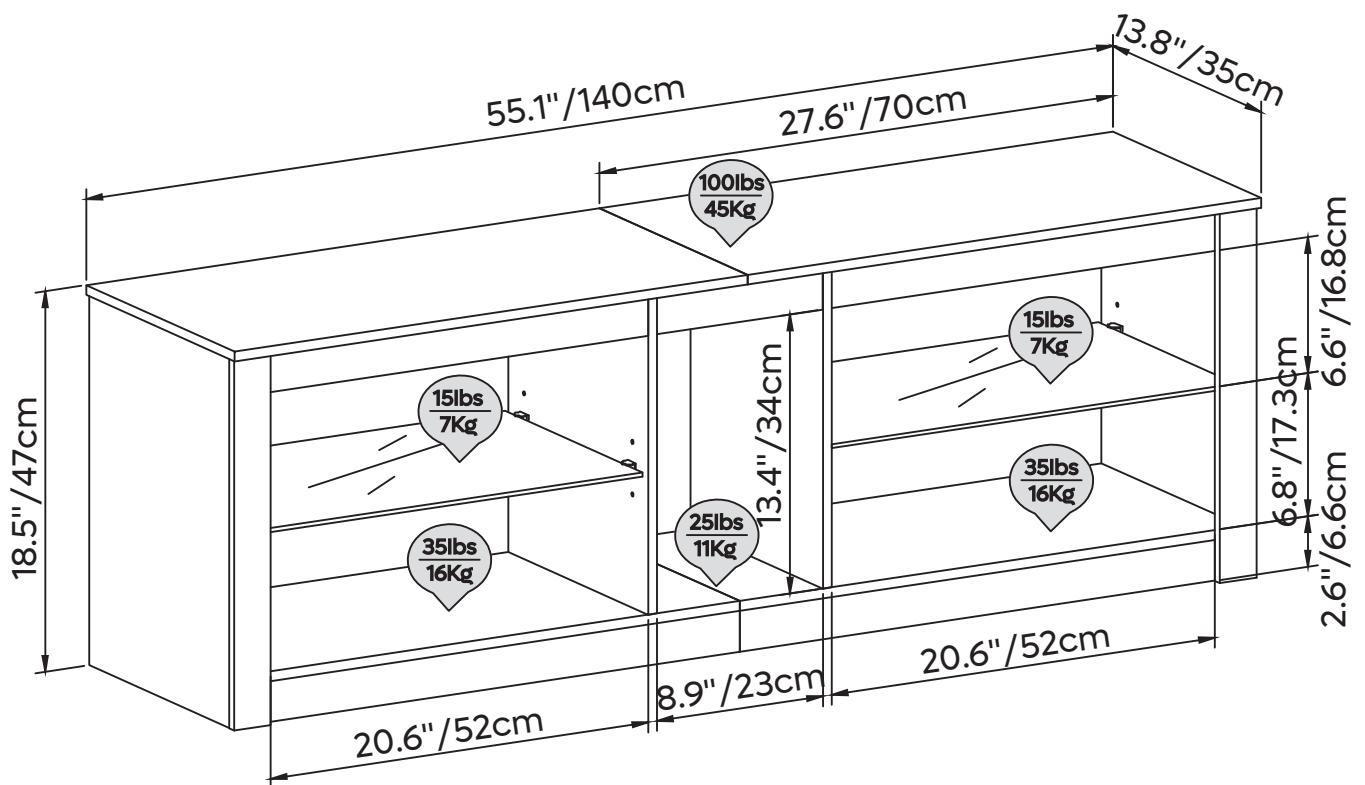

Detailed Installation for Accessory A B

Installation détaillée pour l'accessoire A B
Detaillierte Installation des Zubehörs A B
Installazione dettagliata per l'accessorio A B
Instalación detallada del accesorio A B
カムロック取り付け方

1

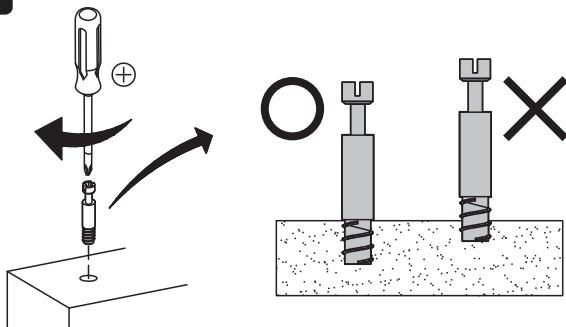

Screw cam dowel on the panel.
Vissez la goupille de came au panneau.
Nockendübel auf die Platte schrauben.
Avvitare il tassello a camme sul pannello.
tornillo de pasador de leva en el panel.
カムロックネジを部品に取り付ける。

2

Place another panel via the dowel.
Placez un autre panneau par le goujon.
Setzen Sie eine weitere Platte über den Dübel ein.
Posizionare un altro pannello tramite il tassello.
Coloque otro panel a través del pasador.
カムロックネジをカムロック穴に差し込む。

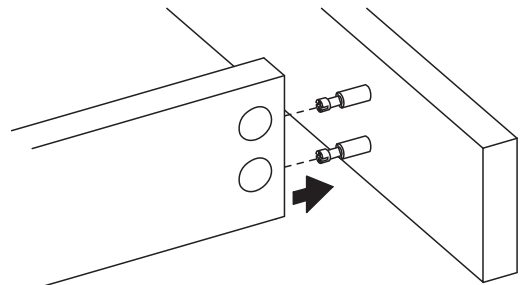

3

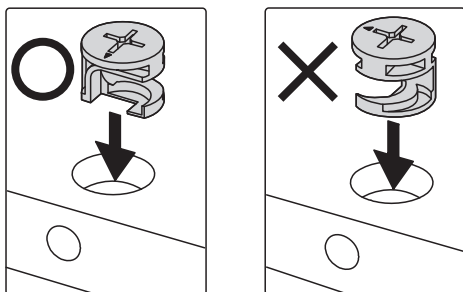

Pay attention to the direction of cam lock when putting it into hole.
Faites attention à la direction du verrou à came en entrant dans le trou.
Achten Sie auf die Richtung des Nockenschlosses, wenn Sie es in das Loch stecken.
Fare attenzione alla direzione della serratura a camme quando lo si inserisce nel foro.
Preste atención a la dirección de la leva de fijación al insertarla en el orificio.
カムロックネジの方向にカムロックの穴の穴の向きを合わせ取り付ける。

4

Tighten up cam lock clockwise until it stops.
Serrez le verrou à came dans le sens des aiguilles d'une montre jusqu'à ce qu'il s'arrête.
Ziehen Sie die Nockenverriegelung im Uhrzeigersinn bis zum Anschlag an.
Stringere la serratura a camme in senso orario fino all'arresto.
Apriete la leva de fijación en sentido horario hasta el tope.
カムロックをドライバーで締め固定する。

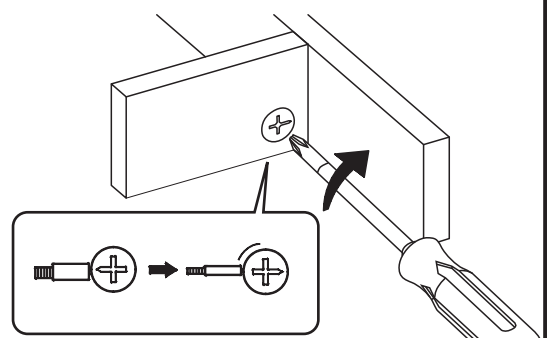

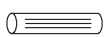
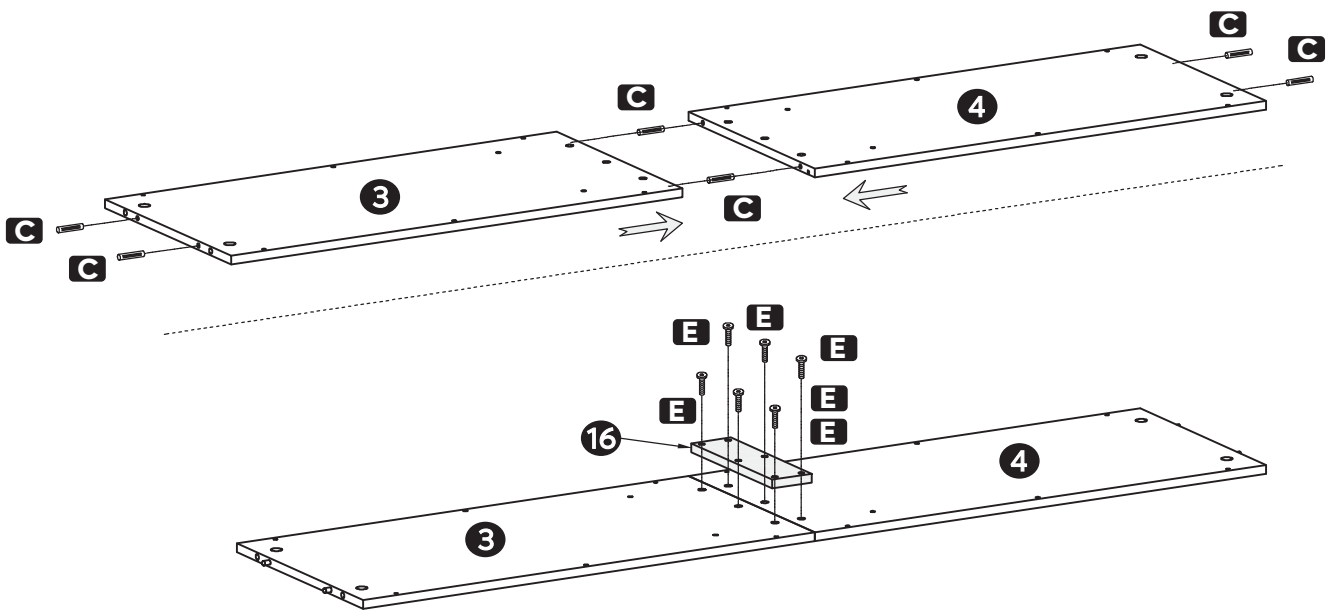



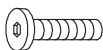

Ø6x30mm x6

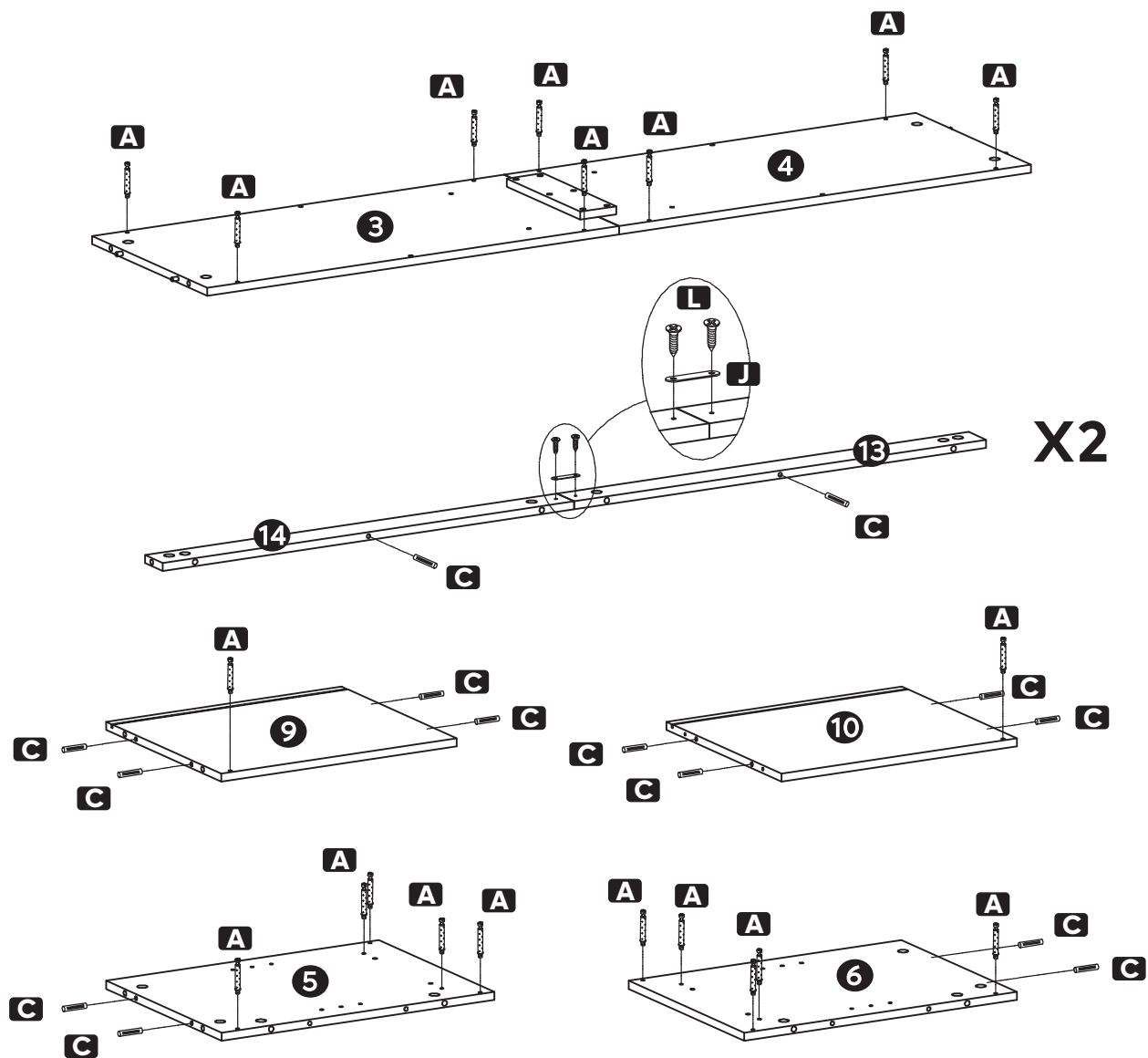

M6x20mm x6



A		ST6x35mm	x20	C		Ø6x30mm	x16
J			x2	L		ST3.5x12mm	x4

3

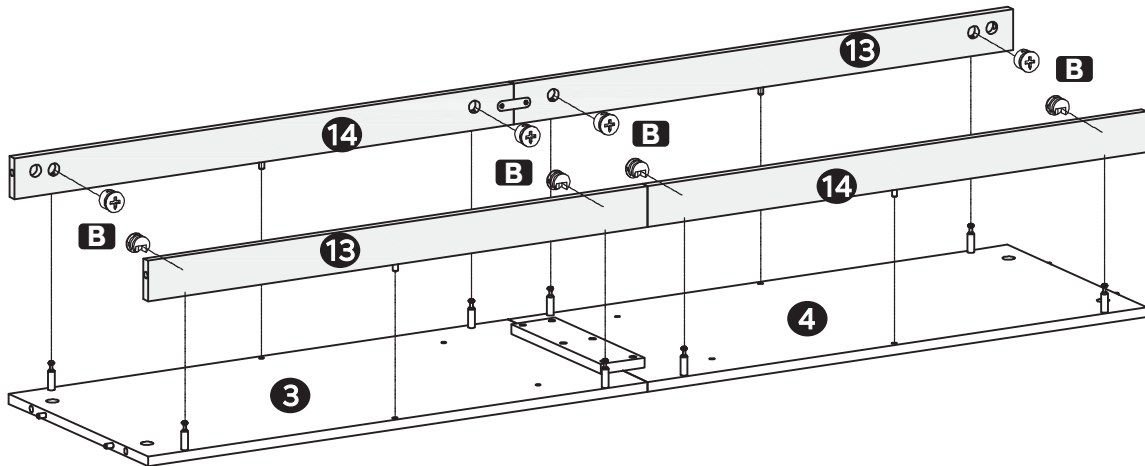

The 3 parts are connected when all Part A and C come into the holes.

Les 3 parties sont connectées lorsque toutes les parties A et C entrent dans les trous

Die 3 Teile sind verbunden, wenn alle Teile A und C in die Löcher kommen.

I 3 pezzi sono collegati quando tutti i pezzi A e C entrano nei fori.

Las 3 piezas se conectan cuando todas las Partes A y C se insertan en los orificios.

すべての部品AとCが穴に入ると、三つの部分が繋がる。

B



Ø15mm

x8

4

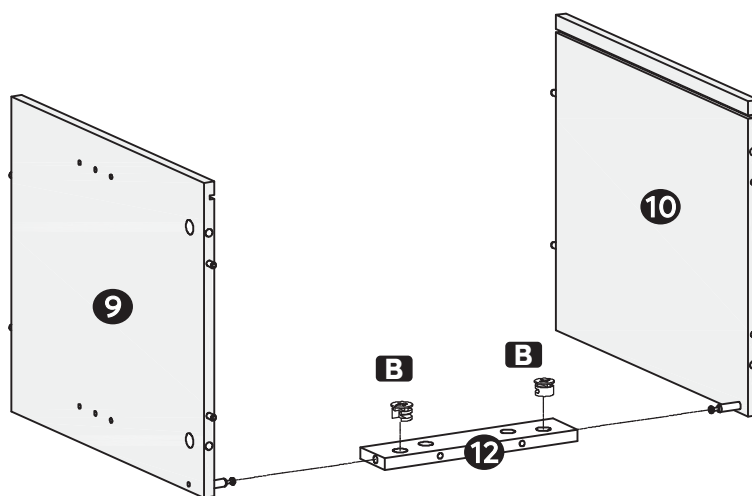

B



Ø15mm

x2

5

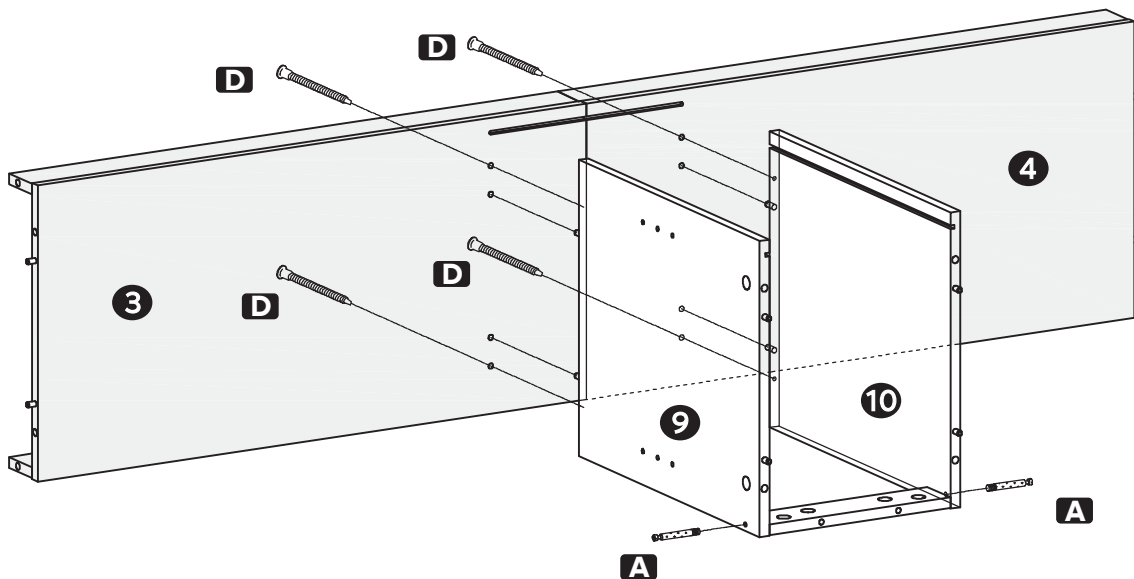

A  ST6x35mm x2

D  ST5x40mm x4

6

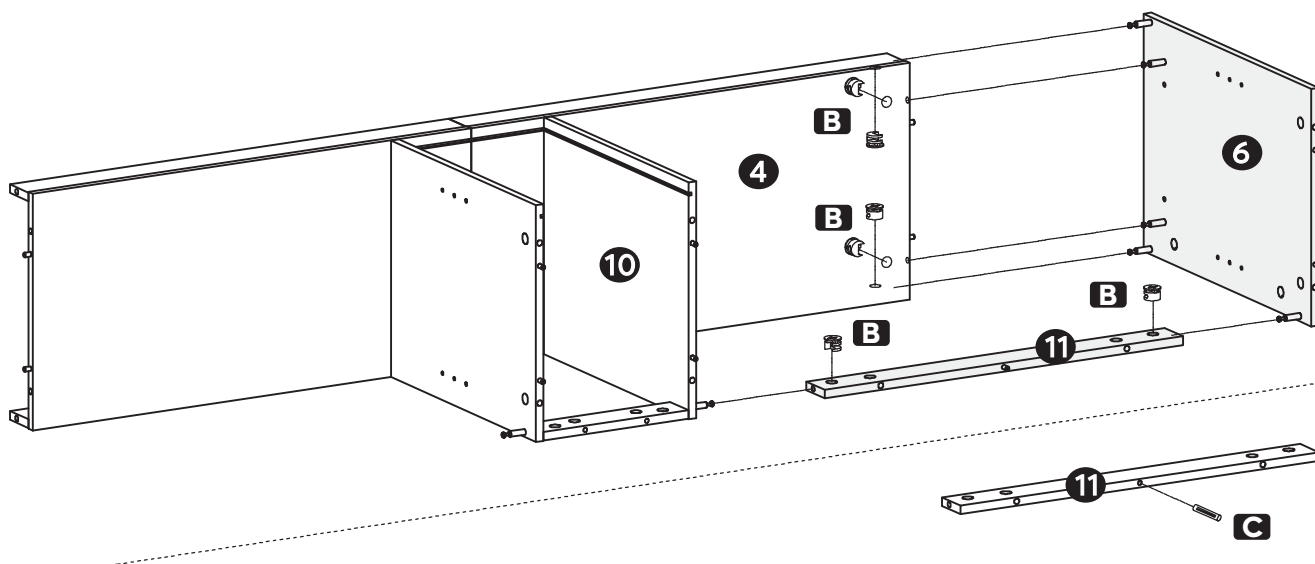

B  Ø15mm x6

C  Ø6x30mm x1

7

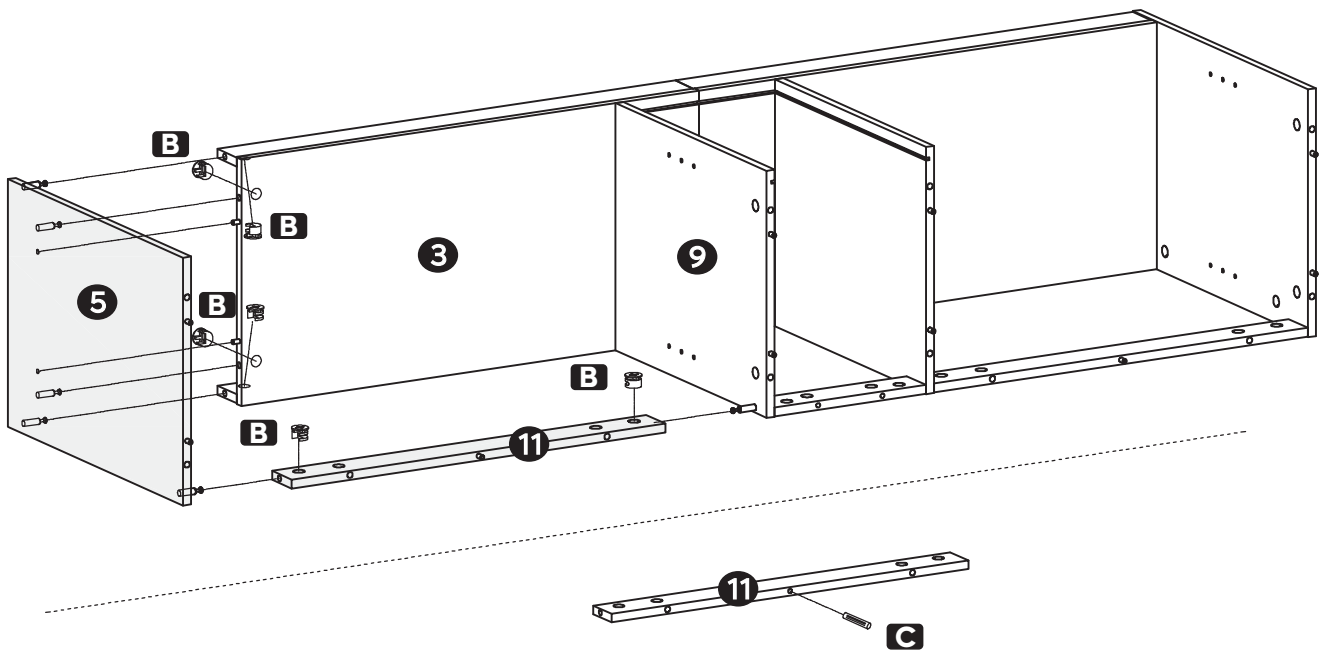

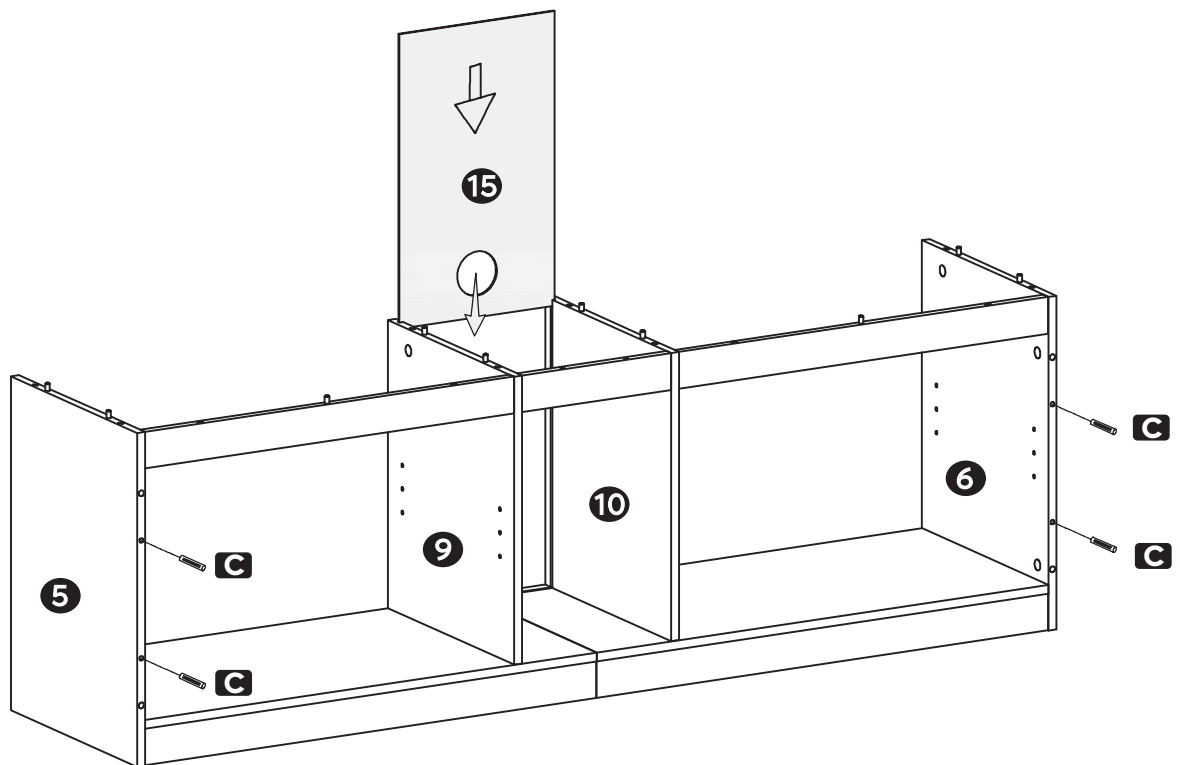

B  Ø15mm x6 **C**  Ø6x30mm x1

8

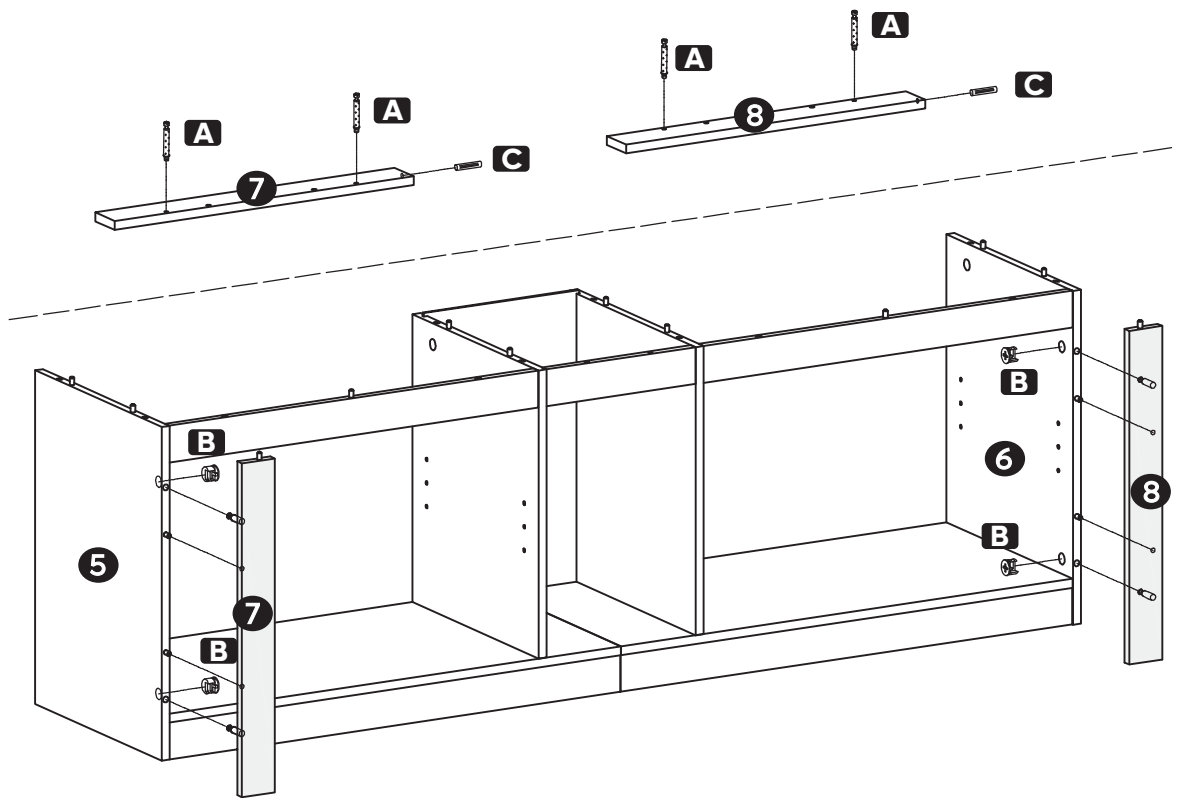

C  Ø6x30mm x4



A  ST6x35mm x4

B  Ø15mm x4

C  Ø6x30mm x2

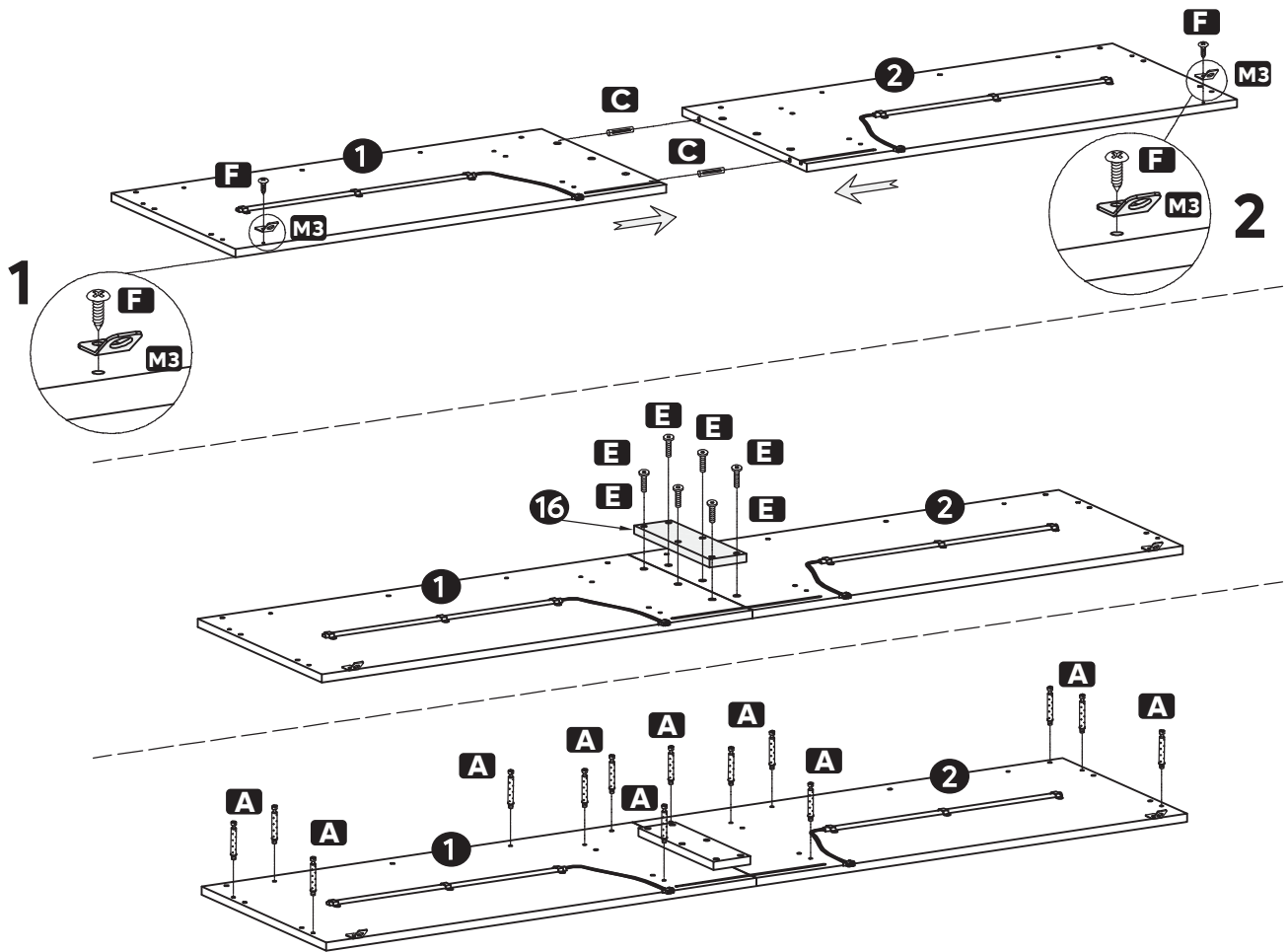

PS 1 & 2 are for the installation of the anti-tilt wall anchor kit of Step 16. You can skip 1 & 2 if you don't want to install an anti-tilt wall anchor kit.





PS 1 e 2 servono per l'installazione del kit di ancoraggio anti-inclinazione a parete nel passo 16. Se non si desidera installare il kit di ancoraggio anti-inclinazione a parete, si possono saltare PS 1 e 2.

1 & 2 sont destinés à l'installation du kit d'ancrage mural anti-basculement de l'étape 16. Vous pouvez sauter les étapes 1 et 2 si vous ne souhaitez pas installer de kit d'ancrage mural anti-basculement.

PD: 1 y 2 son para la instalación del kit de anclaje de pared anti-inclinación correspondiente al paso 16. Puede omitir 1 y 2 si no desea instalar un kit de anclaje de pared anti-inclinación.

PS 1 & 2 werden für die Installation der Kippsicherung in Schritt 16 verwendet. Sie können die Punkte 1 und 2 überspringen, wenn Sie keine Kippsicherung an der Wand anbringen möchten.

注意：ステップ16で防傾斜壁アンカーを取り付けるため、M3部品が必要です。もし、防傾斜壁アンカーを取り付けけないのなら、M3部品抜きで組立ください。

A		ST6x35mm x14	C		Ø6x30mm x2
E		M6x20mm x6	F		ST4x12mm x2
			M3		x2

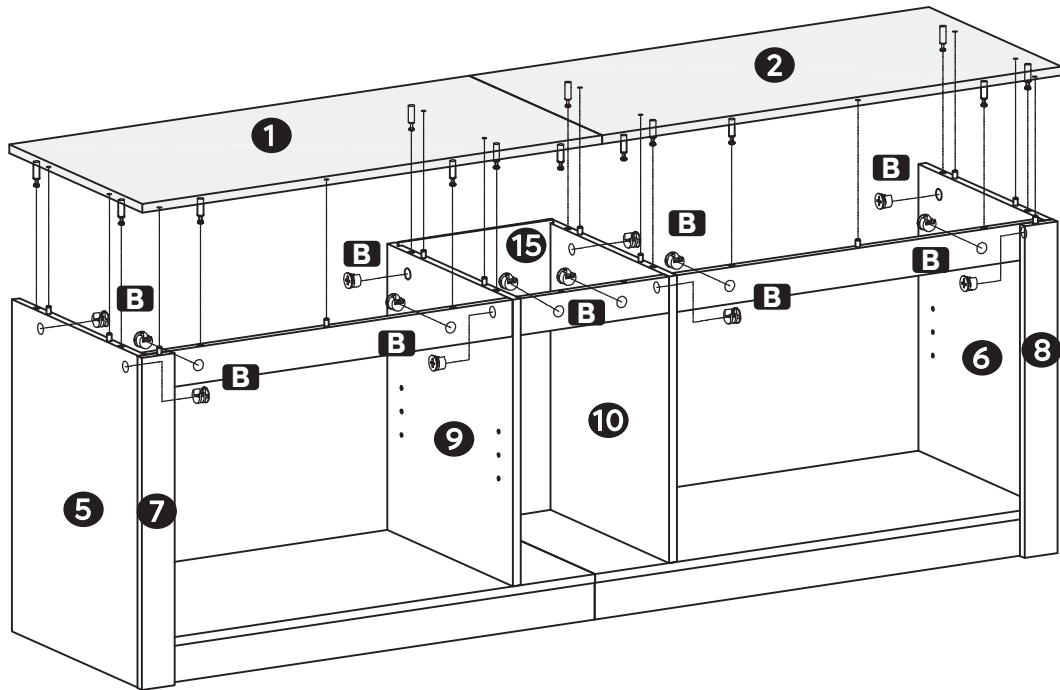

Please check all Part A and C go into the holes.

Veillez vérifier que toutes les parties A et C entrent dans les trous.

Bitte prüfen Sie, ob alle Teile A und C in die Löcher passen.

Si prega di controllare che tutti i pezzi A e C vadano nei fori.

Compruebe que todas las Piezas A y C quedan insertadas en los orificios.

すべての部品Aと部品Cがすでに穴に入れたことを確認してください。

B



Ø15mm x14

12

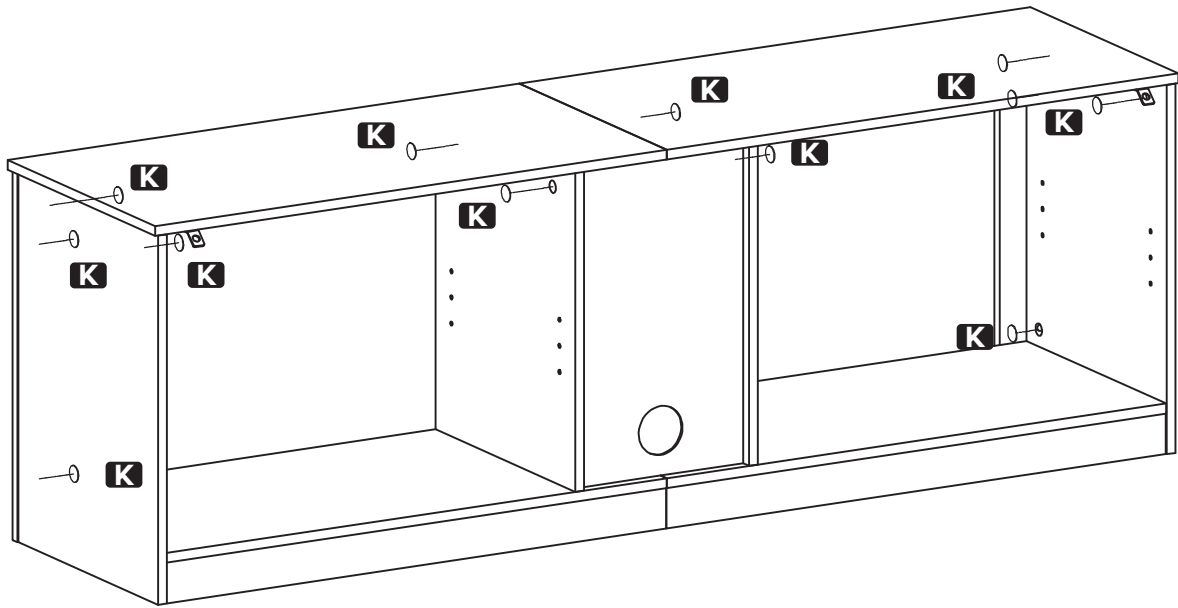

K  Ø22mm x12

13

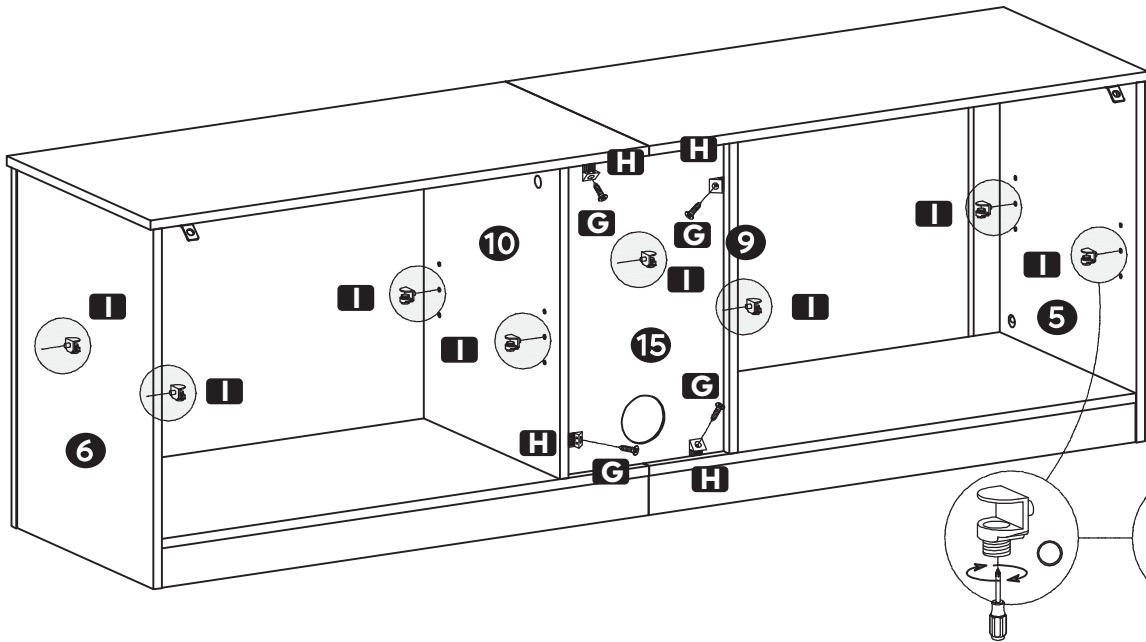

G  ST3x14mm x4

H  x4

I  x8

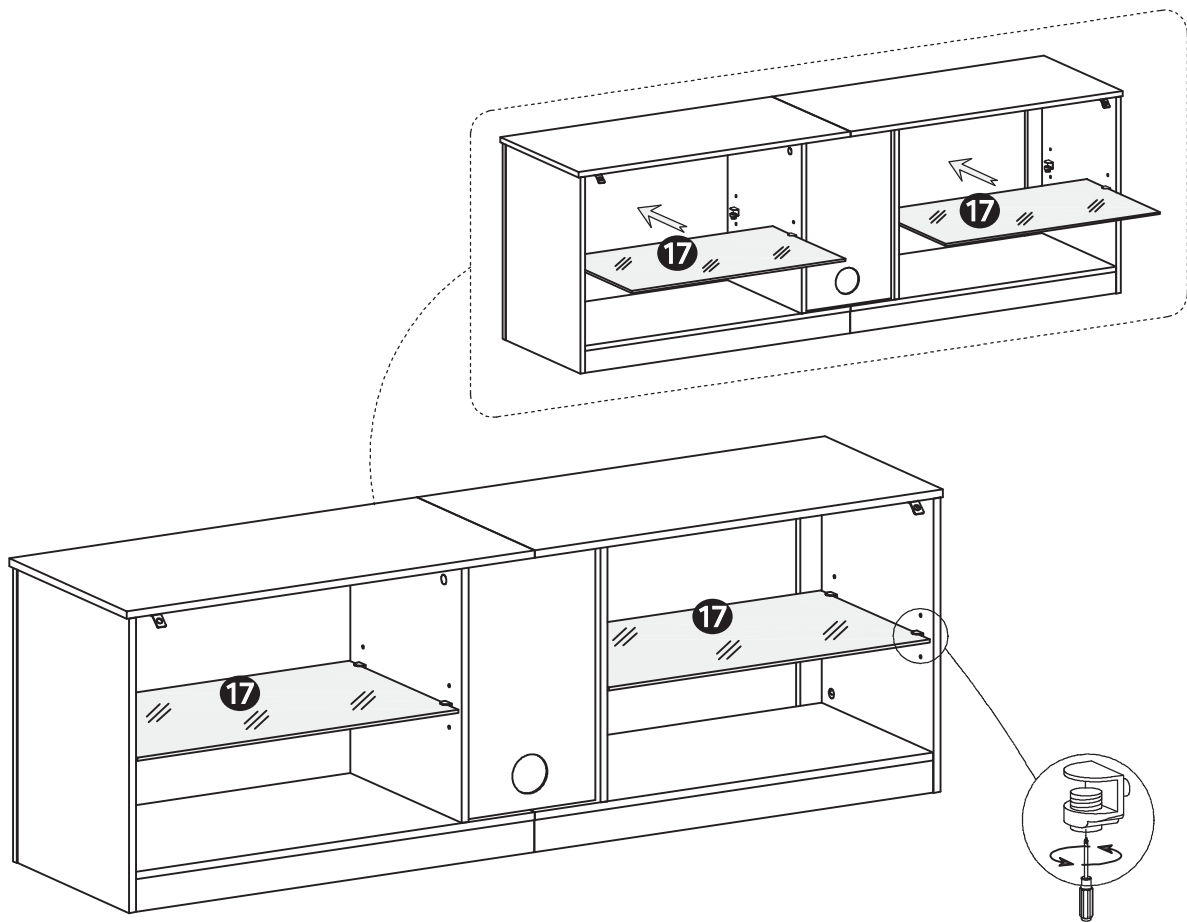

Please be careful of 2 pieces of glass when assembling them.
 Veuillez faire attention à 2 morceaux de verre lorsque vous les installez.
 Bitte achten Sie beim Zusammenbau auf 2 Teile aus Glas.
 Fare particolare attenzione quando si assemblano i 2 pezzi in vetro.
 Tenga cuidado con las 2 piezas de cristal al ensamblarlas.
 2枚のガラスを組み立てる際にはご注意ください。

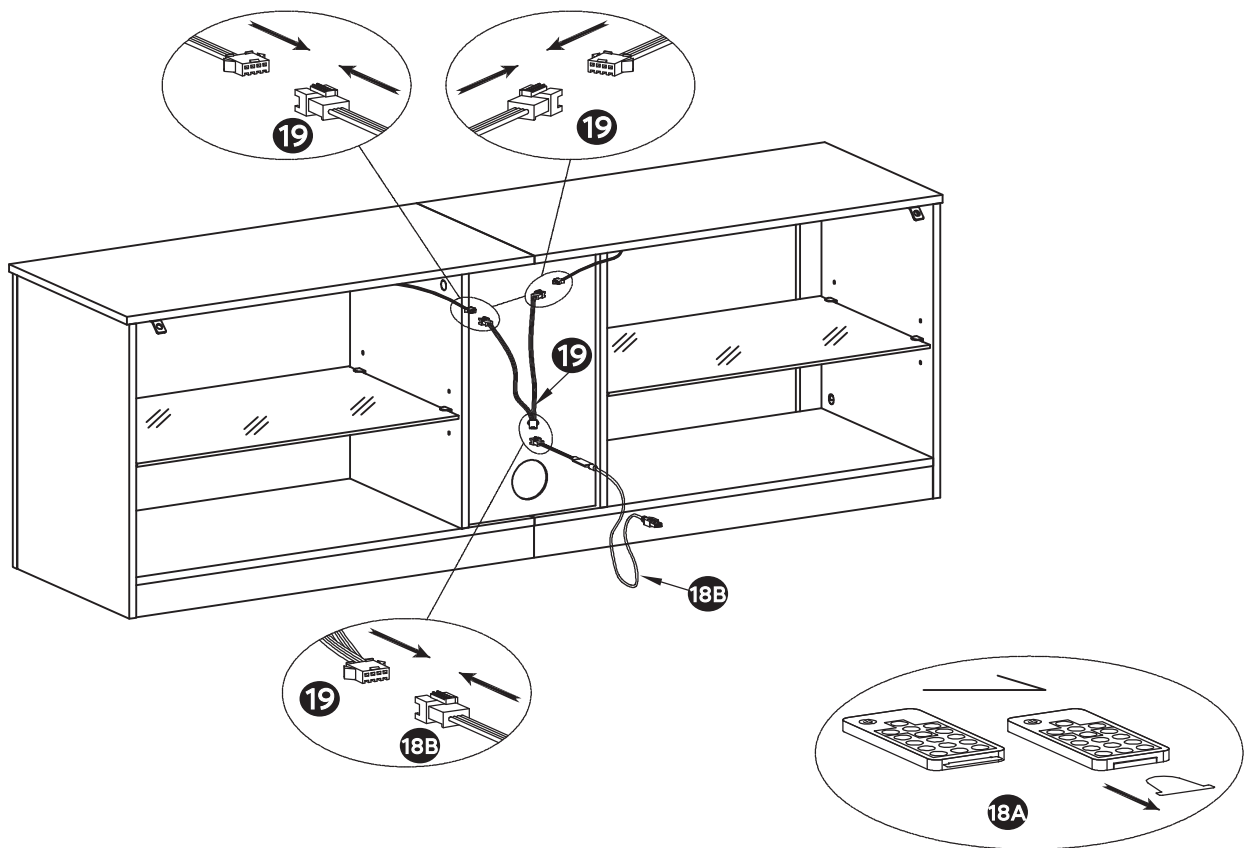

The USB port is in front of the tv stand, the wire is in the back.

Le port USB est devant le meuble tv, le fil est à l'arrière.

Der USB-Anschluss befindet sich an der Vorderseite des Fernsehers, das Kabel ist an der Rückseite.

La porta USB è sulla parte anteriore del supporto TV, il filo è sul retro.

El puerto USB está en la parte delantera del soporte del televisor; el cable está detrás.

USBポートはテレビスタンドの前にあり、ワイヤーは背面にあります。

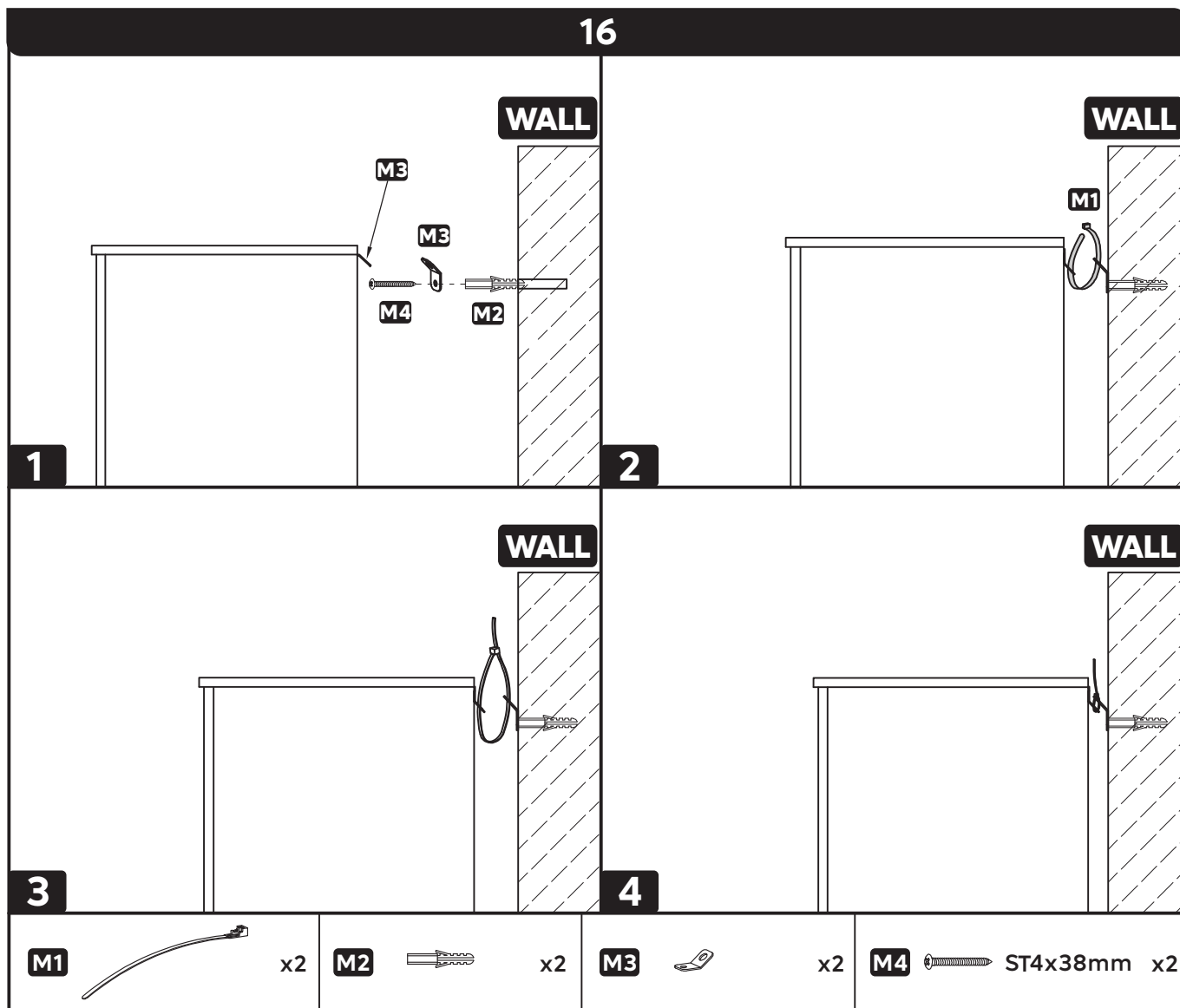

※ **Please fasten the TV Stand to your wall for protection and safety.**

1. Drill 2 holes in the wall and insert M2 into holes.

※ You may need to use rubber mallet for tapping M2.

2. Use M4 to connect M2 with M3 .

3. Use M1 to connect the TV stand and M3 and tighten them as desired before locking in place.

※ **Veillez fixer bien le support TV sur votre mur pour plus de protection et de sécurité.**

1. Percez 2 trous sur le mur et insérez M2 dans les trous.

※ Vous devrez peut-être utiliser un maillet en caoutchouc pour frapper M2.

2. Utilisez M4 pour connecter au M2 avec M3.

3. Utilisez M1 pour connecter au support TV et M3 et serrez-les comme vous le souhaitez avant de verrouiller sur la place adaptée.

※Bitte befestigen Sie die TV-Anrichte zum Schutz und zur Sicherheit an Ihrer Wand.

1. Bohren Sie 2 Löcher in die Wand und setzen Sie M2 in die Löcher ein.

※Möglicherweise müssen Sie einen Gummihammer für das Klopfen von M2 verwenden.

2. Verwenden Sie M4, um M2 mit M3 zu verbinden.

3. Verbinden Sie den TV-Ständer mit M1 und M3 und ziehen Sie sie wie gewünscht fest, bevor Sie sie einrasten lassen.

※Si prega di fissare il supporto TV alla parete per protezione e sicurezza.

1. Praticare 2 fori nel muro e inserire M2 nei fori. Potrebbe essere necessario usare un martello di gomma per fissare M2.

※Potrebbe essere necessario usare un martello di gomma per fissare il pezzo M2.

2. Usare M4 per collegare M2 con M3.

3. Usare M1 per collegare il supporto TV e M3 e stringerli come desiderato prima di bloccarli in posizione.

※Fije el soporte del TV a la pared como medida de protección y seguridad.

1. Taladre 2 orificios en la pared e inserte tornillos M2 en los orificios.

※Es posible que tenga que utilizar el mazo de goma para golpear el M2.

2. Utilice M4 para conectar M2 con M3.

3. Utilice M1 para conectar los M3 correspondientes, y apriételos según sus preferencias antes de inmovilizarlos en su posición.

※安全のためにテレビスタンドを壁に固定してください。

1、壁に2つ穴を開け、M2を穴に差し込む。

M2を叩くにはラバーハンマーが必要かもしれません。

2、M4を使って、M2とM3を繋げる。

3、M1を使用してテレビスタンドとM3を接続し、所定の位置にロックする前に必要に応じて締め付ける。