

SHORT CABINET DOORS

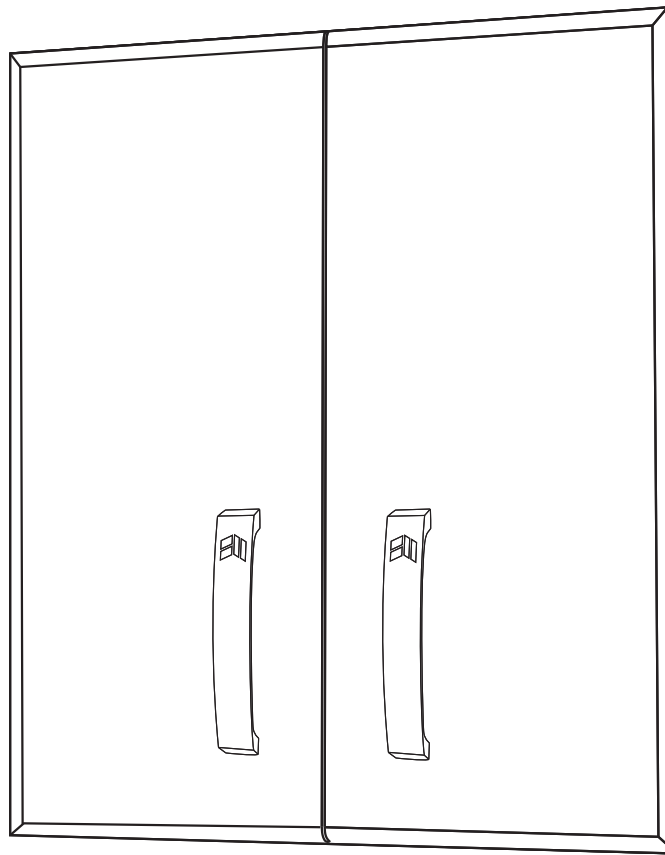



Model: **FWC-D02.3**

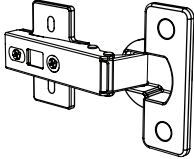

1775 W 2300 S
Salt Lake City, UT 84119
(877) 356-9925
customerservice@flowwall.com

PARTS LIST

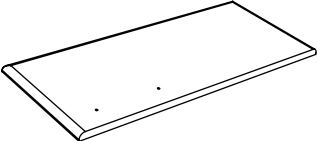
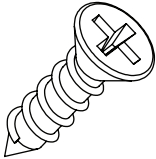
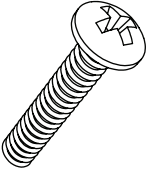
NO.	PICTURE	PART DESCRIPTION	QTY.
A		Soft close hinge	4
B		Handle	2
C		Door	2
D		Hinge screw	16
E		Handle screw	4

Step 1.

Doors - Assemble the hinges (A) to the doors (C) with hinge screws (D) (Soft close hinges are fully adjustable). Add handles (B) to each door (C) with handle screws (E). (Note: handle holes may require the use of a screwdriver, awl, or drill bit to pierce through the outside laminate).

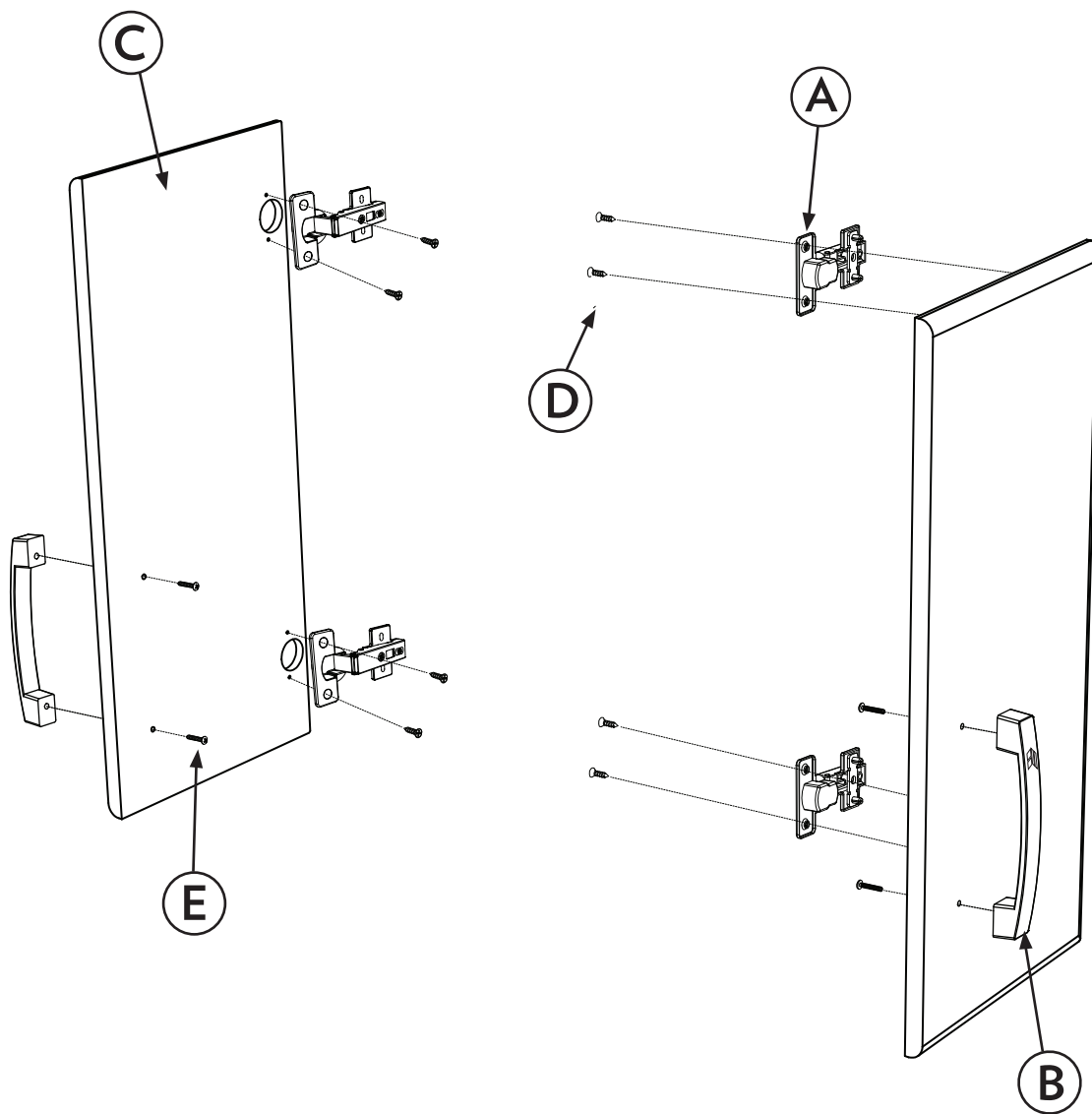

Step 2.

Hinges - Assemble the doors (C) with the hinges (A) to the cabinet with hinge screws (D).

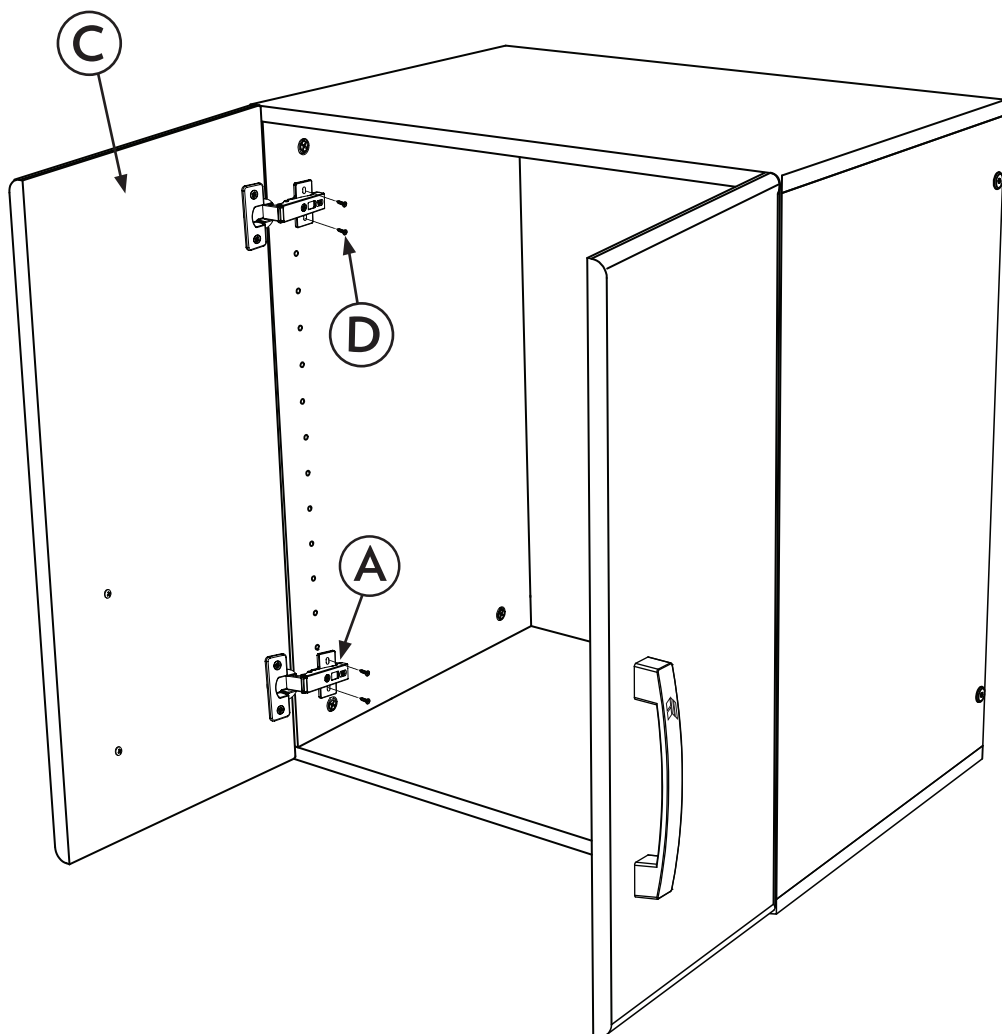

ADJUST HINGES

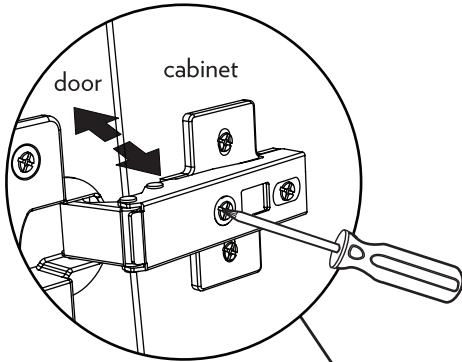

HORIZONTAL ADJUSTMENT

Tighten the front screw (turn clockwise) to move the door nearer toward the frame; loosen it (turn counterclockwise) to move the door away from the frame.

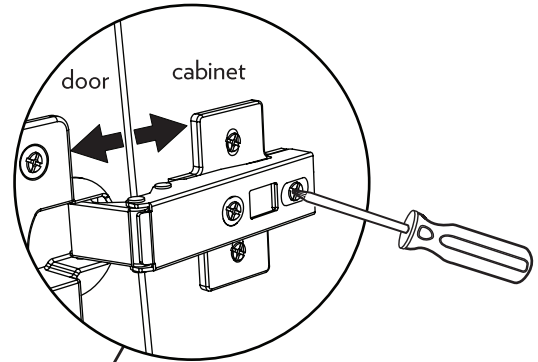

HORIZONTAL ADJUSTMENT

Loosen this screw and adjust the gap between the door and cabinet body. Tighten screw to fix into place.

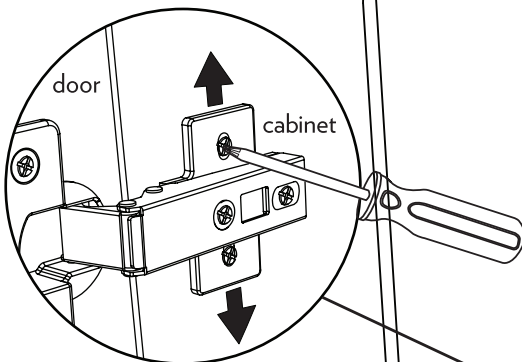

VERTICAL ADJUSTMENT

Loosen the top and bottom screws. Be sure not to completely remove them. Adjust the door up or down as necessary. Firmly tighten the screws.

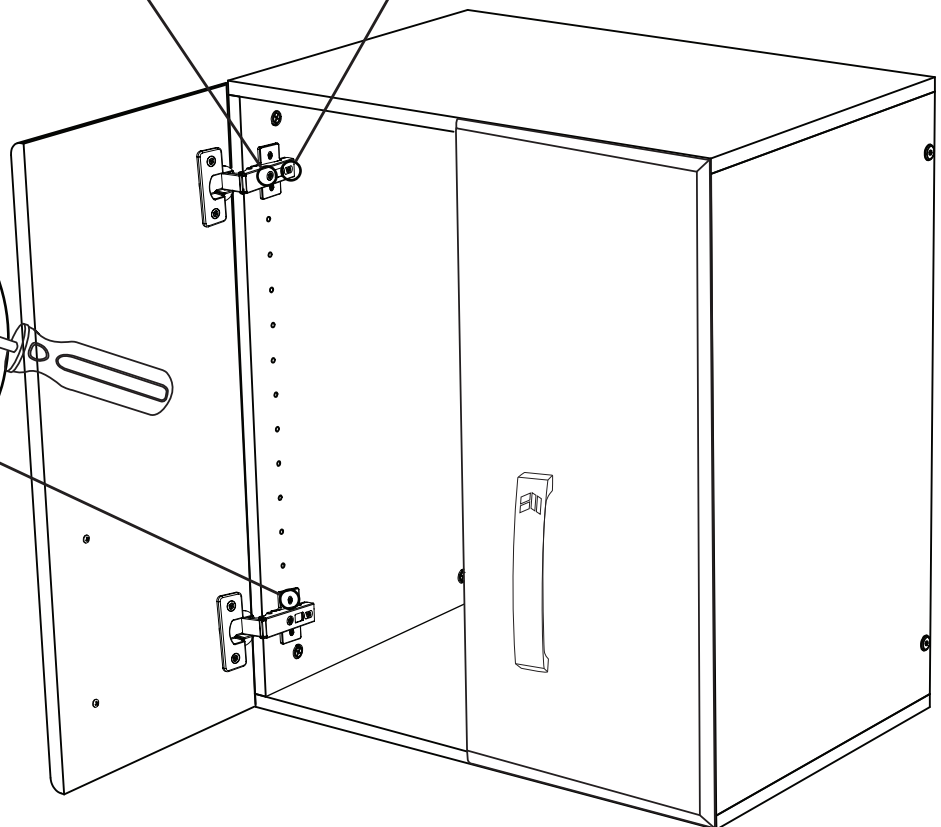

PORTES DU CABINET PETIT

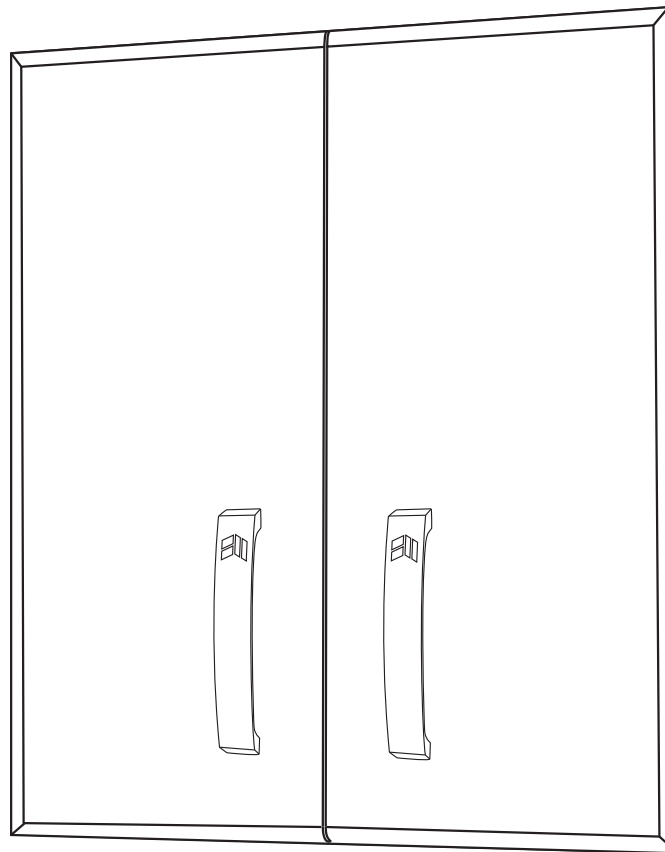



Modèle: **FWC-D02.3**

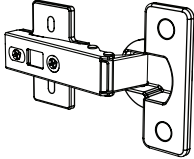

1775 W 2300 S
Salt Lake City, UT 84119
(877) 356-9925
customerservice@flowwall.com

LISTE DES PIÈCES

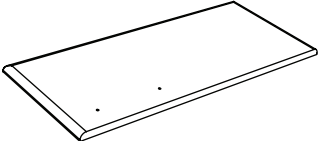
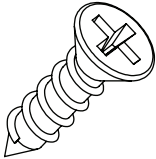
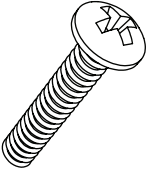
NO.	IMAGE	RÉFÉRENCE DESCRIPTION	QTE.
A		Charnière de fermeture douce	4
B		Poignées	2
C		Portes	2
D		Vis de charnière	16
E		Vis de poignée	4

Étape 1.

Portes - Assemblez les charnières (A) aux portes (C) avec la vis de charnières (D) (les charnières de fermeture douce sont pleinement ajustables). Ajoutez les poignées (B) à chaque porte avec la vis de poignées (E).
 (Note : les trous pour les poignées peuvent nécessiter l'utilisation d'un tournevis, d'un poinçon ou d'une mèche pour percer à l'extérieur du laminé).

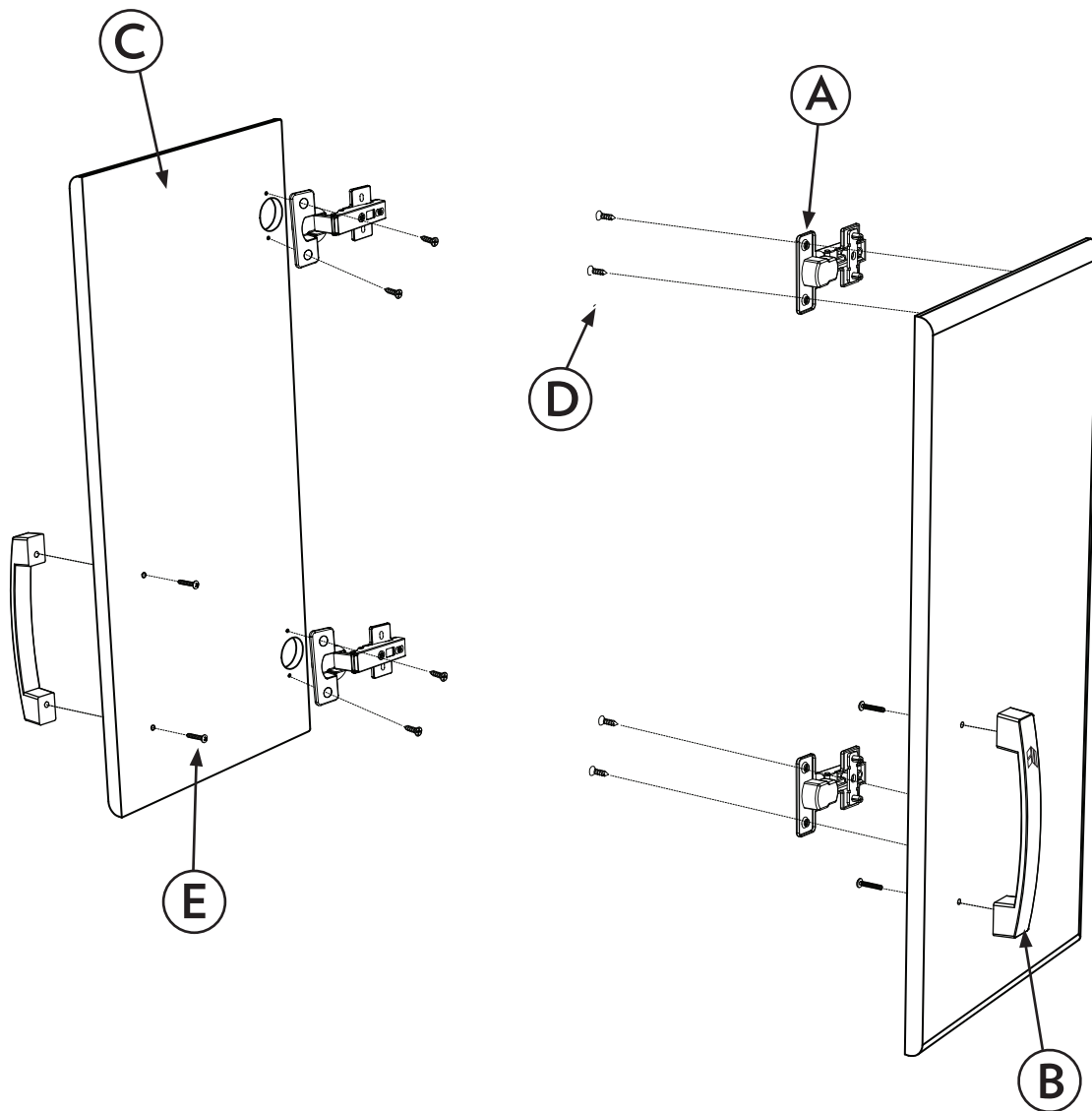



Étape 2.

Charnière - Assemblez les portes (C) avec les charnières (A) au cabinet avec la vis de charnières (D).

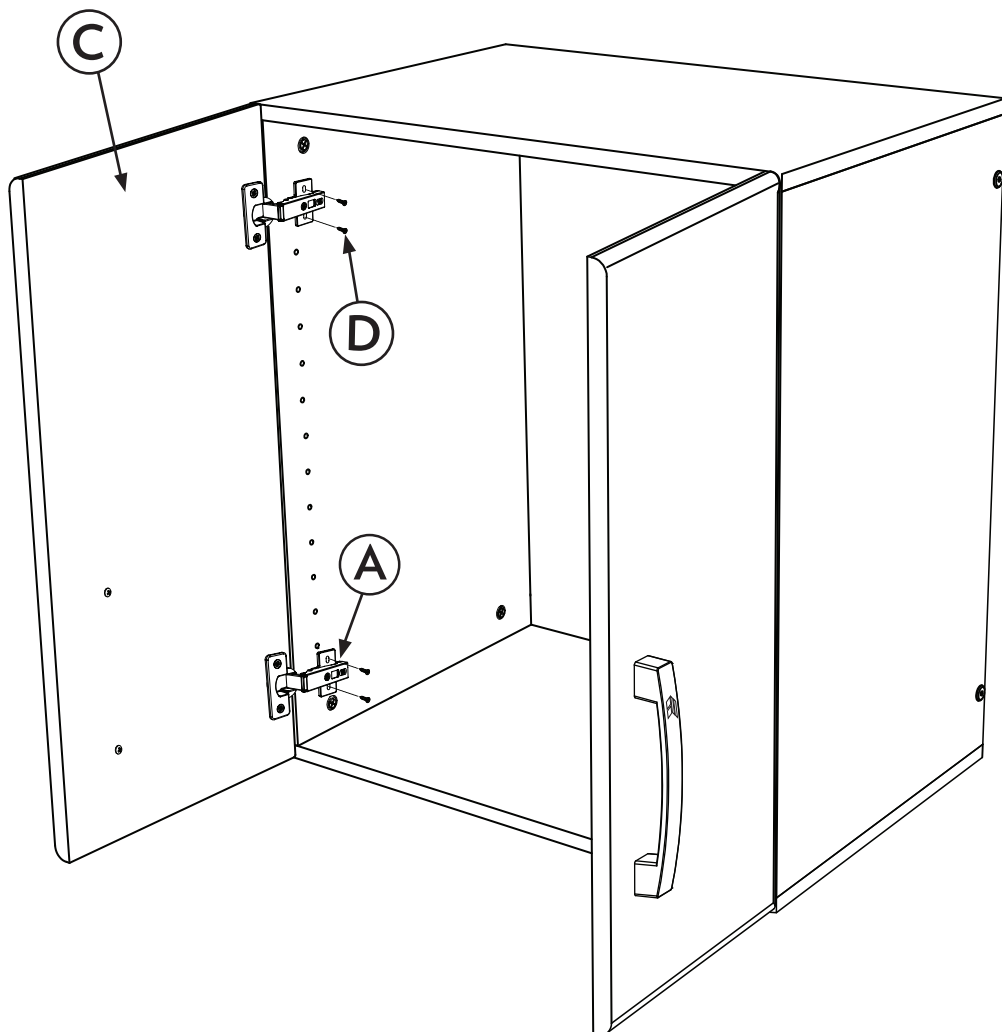

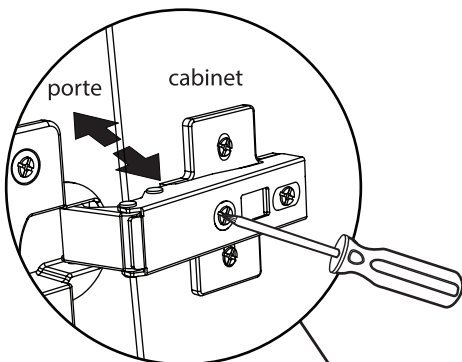
AJUSTER LES CHARNIÈRES

AJUSTEMENT HORIZONTAL

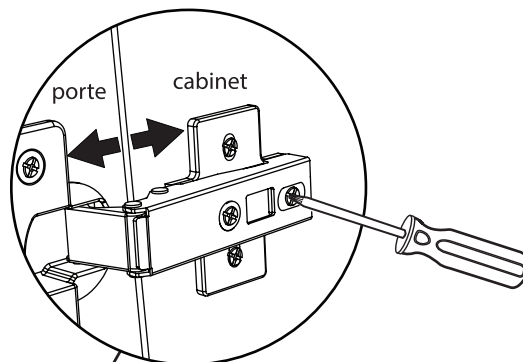
Serrez la vis avant (dans le sens des aiguilles d'une montre) pour rapprocher la porte du cadre, desserrer (tourner dans le sens antihoraire) pour éloigner la porte du cadre.

AJUSTEMENT HORIZONTAL

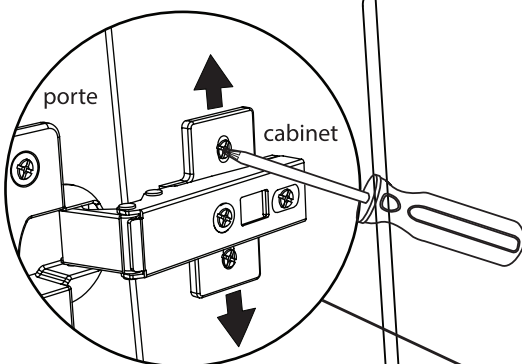
Desserrez la vis arrière et réglez l'écart entre la porte et le corps de l'armoire. Serrez la vis pour la fixer en place.

AJUSTEMENT VERTICAL

Desserrez les vis supérieure et inférieure. Assurez-vous de ne pas les supprimer complètement. Ajustez la porte vers le haut ou vers le bas si nécessaire. Serrez fermement les vis.

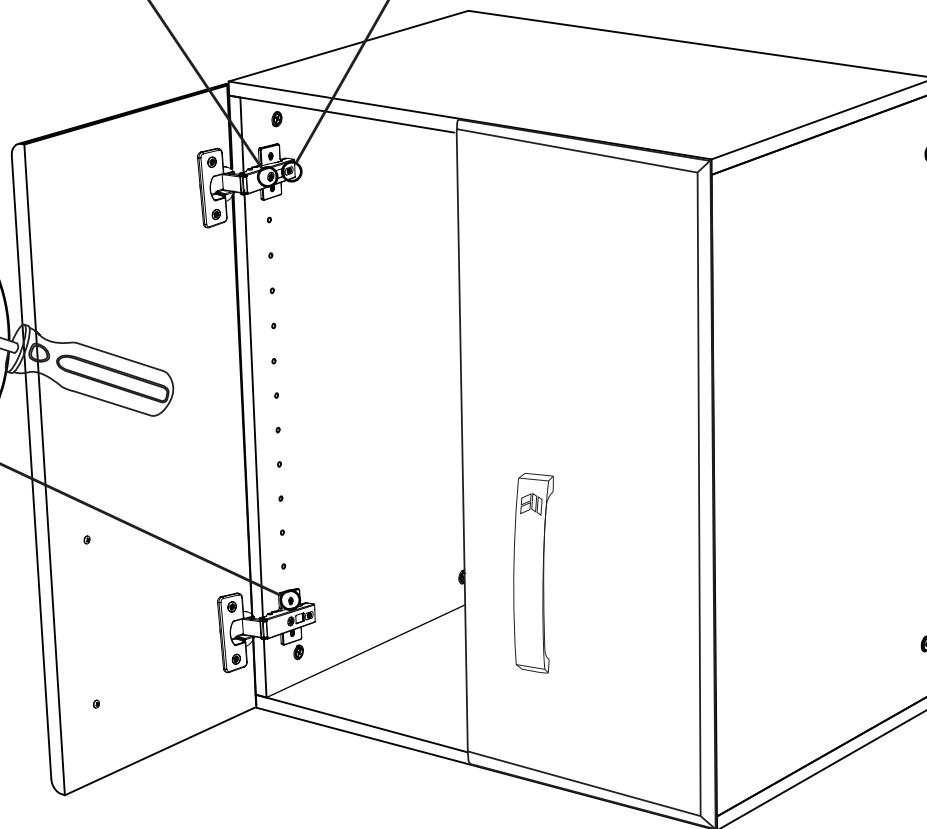

PUERTAS DEL GABINETE BAJA

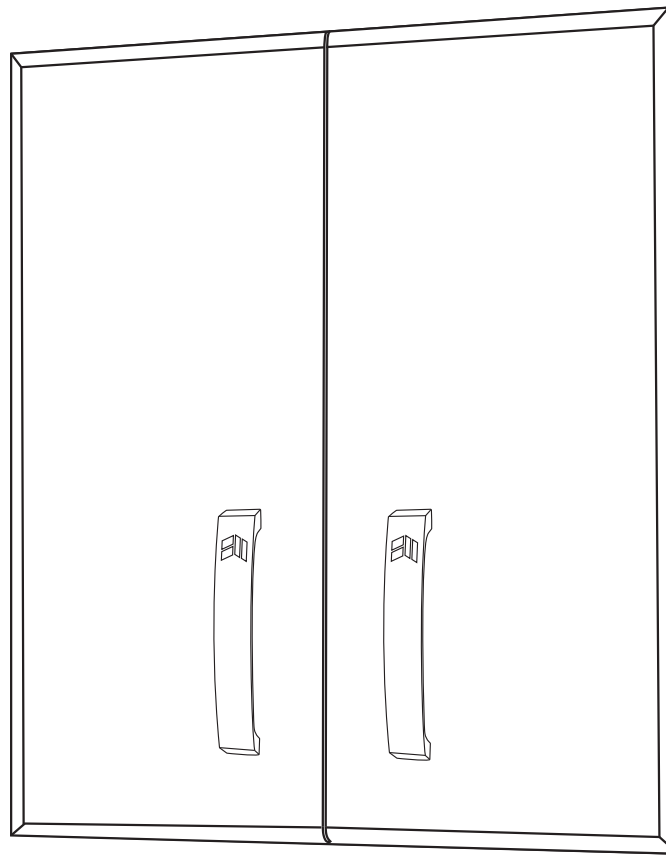

Modelo: **FWC-D02.3**





1775 W 2300 S

Salt Lake City, UT 84119

(877) 356-9925

customerservice@flowwall.com

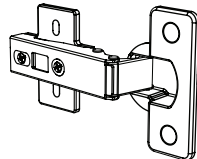
LISTA DE PARTES

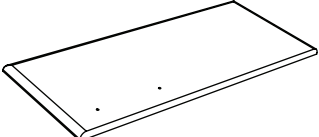
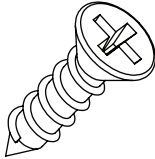
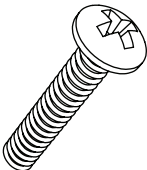
NO.	IMAGE	DESCRIPCIÓN (PARTE)	CANT.
A		Bisagra de cierre suave	4
B		Manija	2
C		Puerta	2
D		Tornillo de bisagra	16
E		Tornillo de manija	4

Paso 1.

Puertas: Una las bisagras (A) a las puertas (C) con los tornillos de bisagra (D) (las bisagra de cierre suave son completamente ajustables). Añada las manijas (B) a cada puerta (C) con los tornillos de manijas (E). (Nota: los orificios de la manija podrían requerir el uso de un destornillador, un punzón o una broca para perforar a través del laminado exterior).

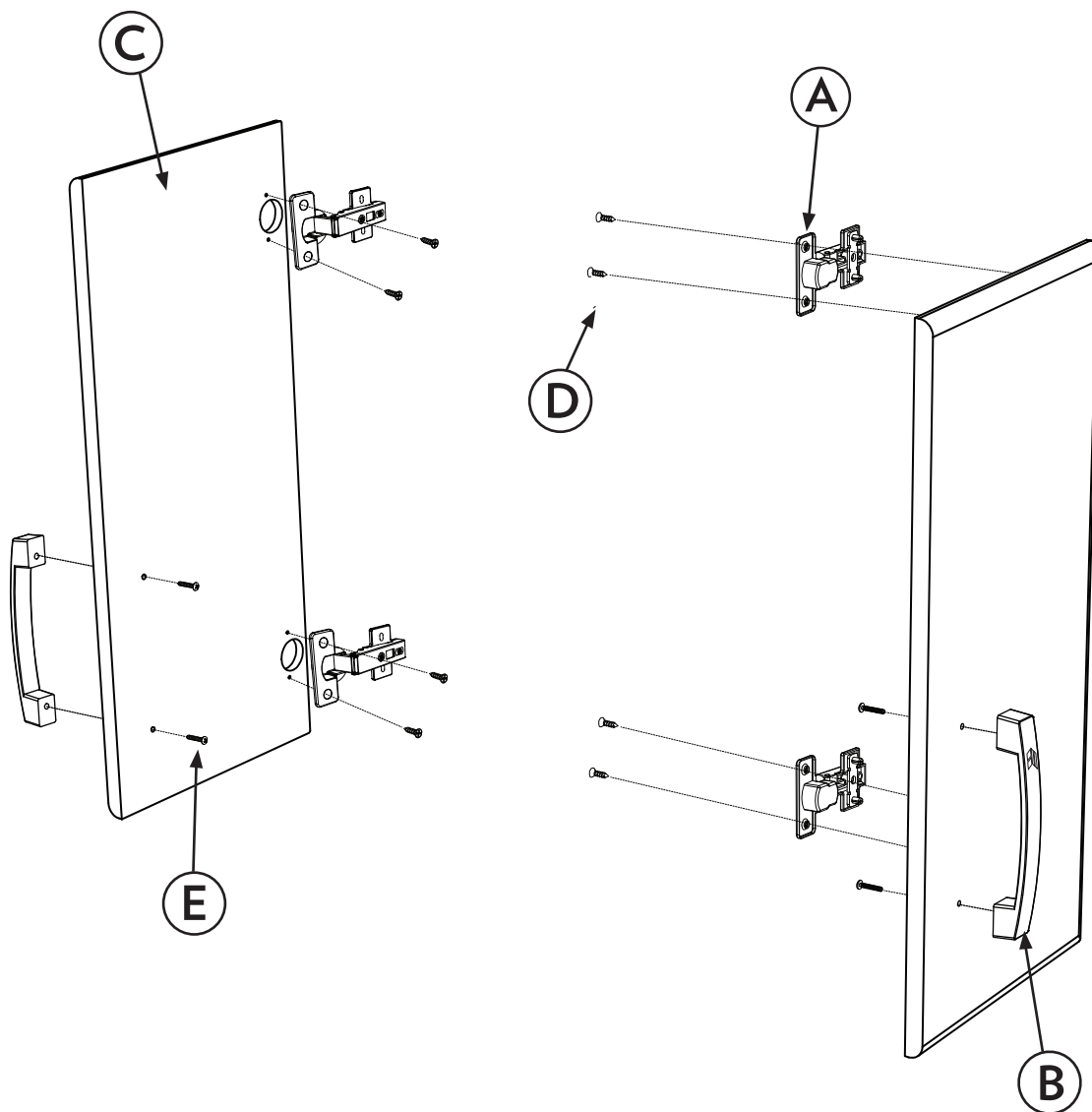

Paso 2. Bisagras - Una las puertas (C) con las bisagras (A) al gabinete con los tornillos (D).

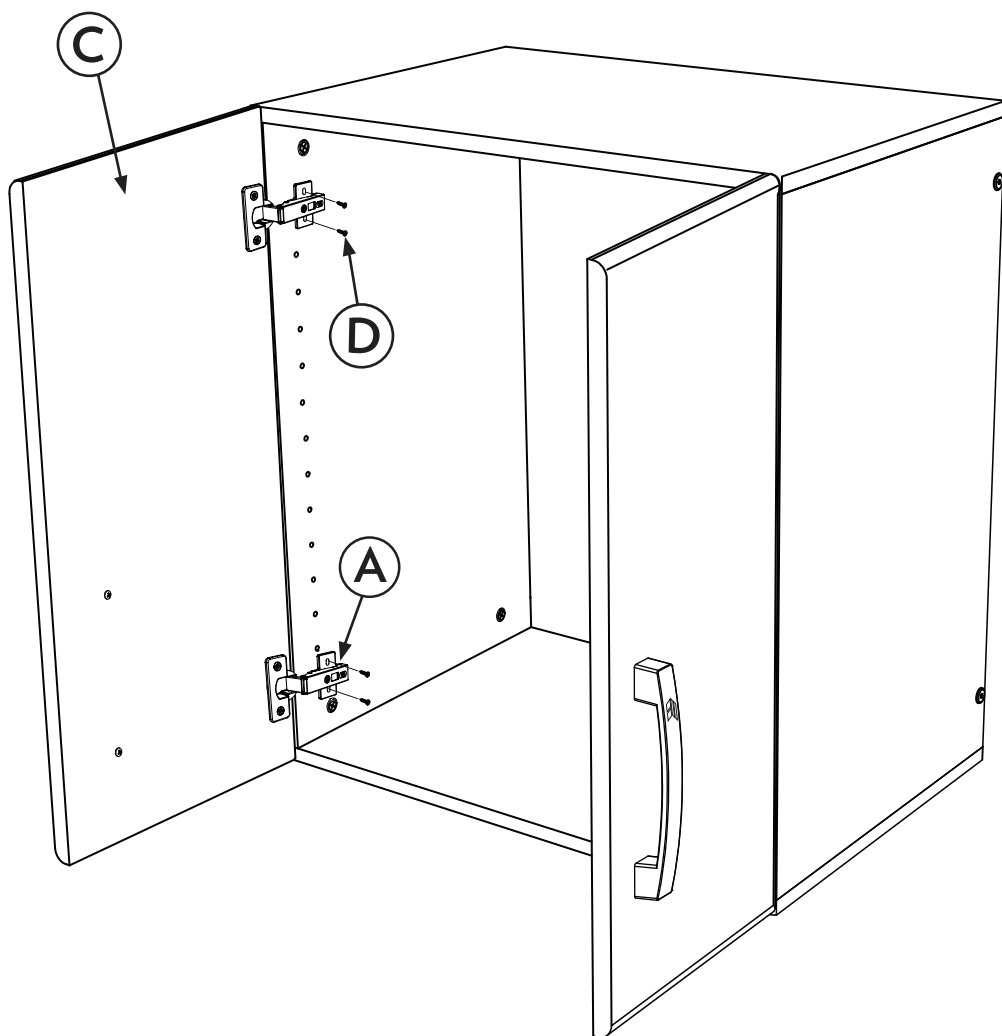

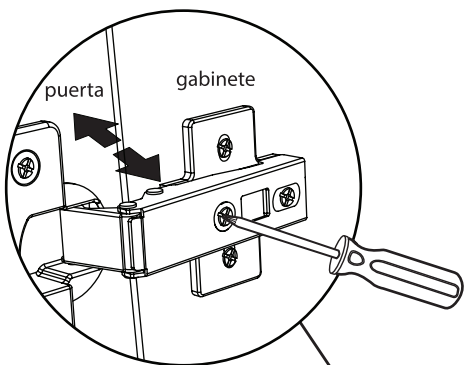
AJUSTAR BISAGRAS

AJUSTE HORIZONTAL

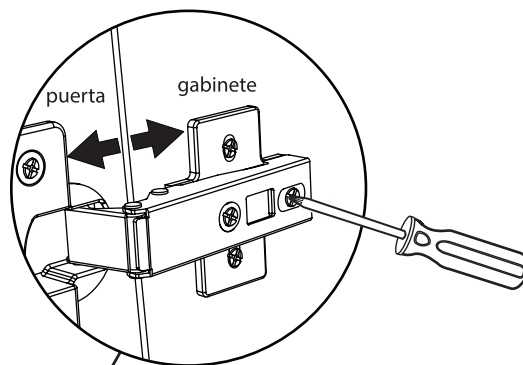
Apriete el tornillo del frente (gírelo a la derecha) para mover la puerta más cerca del gabinete; aflojelo (girar hacia la izquierda) para alejar la puerta del gabinete.

AJUSTE HORIZONTAL

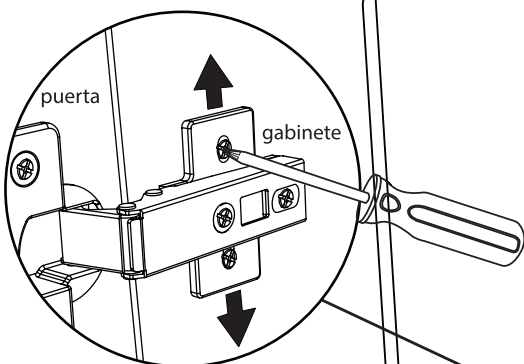
Afloje el tornillo trasero y ajuste la separación entre la puerta y el gabinete. Vuelva a apretar el tornillo para fijarlo en su lugar.

AJUSTE VERTICAL

Afloje los tornillos superior e inferior. Asegúrese de no quitarlos por completo. Ajuste la puerta hacia arriba o hacia abajo según sea necesario. Apriete firmemente los tornillos.

