

## **ASSEMBLY INSTRUCTIONS**

- Our clear, easy-to-follow, step-by-step instructions will guide you.
- Do not skip any steps. It is of utmost importance to assemble all of the parts according to the directions.
- Item identification: For ease of identification, all parts are labelled to correspond to the step number in which the part is used.

## **IMPORTANT**

- Read the following instructions carefully before using the chair.
- Be aware that some parts are heavy and have sharp edges.
- Do not overtighten screws (insert all screws before tightening screws).
- Firmly secure all bolts , screws and nuts before use.
- Please do not exceed the weight limitations of this item.
- Reconfirm that all bolts , screws , and nuts are secure every 90 days.

## **CARE & SAFETY**









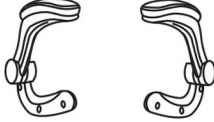

- Always use on firm level ground.
- Keep all children and pets away from the assembly area. Children and pets should be supervised while the product is being assembled.
- Vacuuming picks up dust and reduces the need for professional cleaning.
- In case of fire, do not attempt to extinguish any burning polypro-pyleneene with water.
- Be very careful when assembling chairs to avoid smashing your hands or fingers.
- Please contact Customer Service if you have any problems or discover any missing parts.

## **MAINTENANCE**

- Wash the surface with a soft cloth soaked in mild detergent and warm water. Pay attention to drying the water in time. Do not use solvents or abrasive kitchen cleaners.
- Vacuum fabric as needed using an upholstery attachment.
- Do not use or store this item in the proximity of open flame or flammable/combustible chemicals.
- Do not brush fabric or use a vacuum attachment with a rotary brush.
- Brushing may permanently damage the nap or change the character of the fabric.

Thank you for purchasing our products. Please read this manual before assembly. Assemble all components in sequence. After assembly, retain the instructions properly. Confirm all parts are present (13 items in total)

## Accessories List

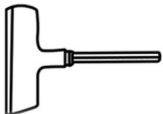
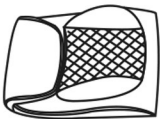
Item No.	Reference Image	Qty	Item No.	Reference Image	Qty
<b>A</b>	Central base tube 	1	<b>H</b>	Armrest frame 	2
<b>B</b>	Base tubes 	5	<b>I</b>	M6*20mm 	10
<b>C</b>	Air rod 	1	<b>J</b>	M6*20mm 	4
<b>D</b>	Castors 	5	<b>K</b>	M6*25mm 	8
<b>E</b>	Base plate 	1	<b>L</b>	Screw caps 	8
<b>F</b>	Seat cushion 	1	<b>M</b>		1
<b>G</b>	Backrest 	1			

# Assembly Instruction

## Step 1

Insert 5 base tubes (B) into central base tube (A), align with the holes and tighten 10 M6\*20 screws (I).

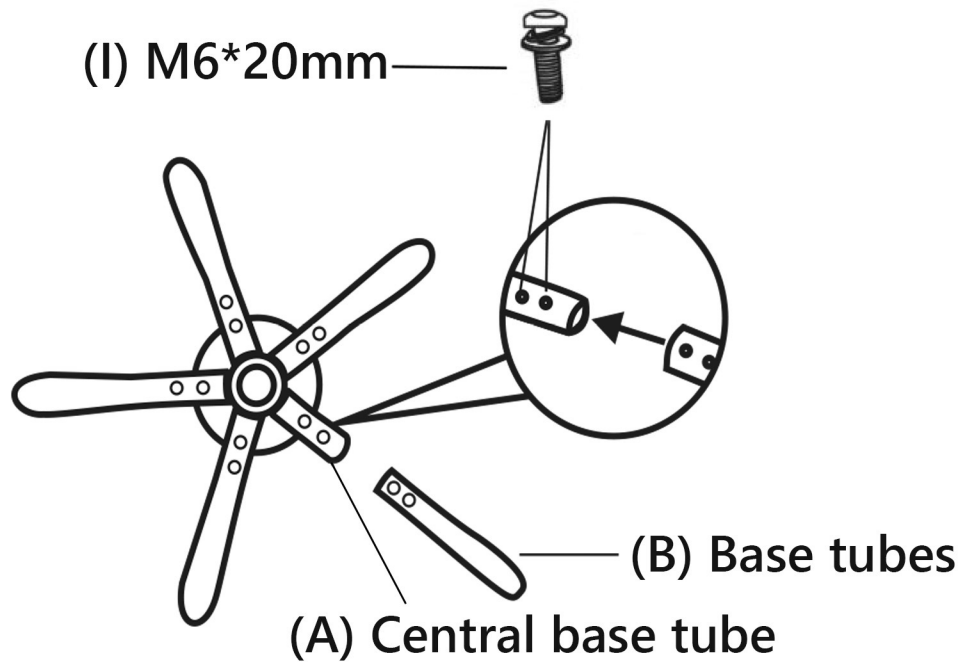

## Step 2

Insert 5 castors (D) into base tube (B), please make sure castors are securely installed before use. Put air rod (C) into the hole of central tube (A).

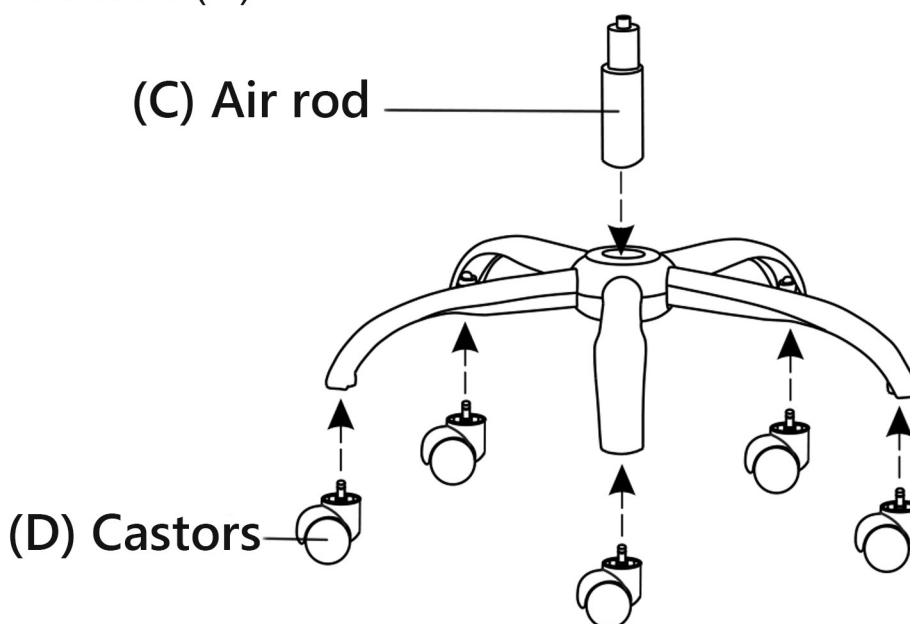

### Step 3

Attach the base plate (E) to the seat cushion (F) with 4 M6\*20 screws (J) .

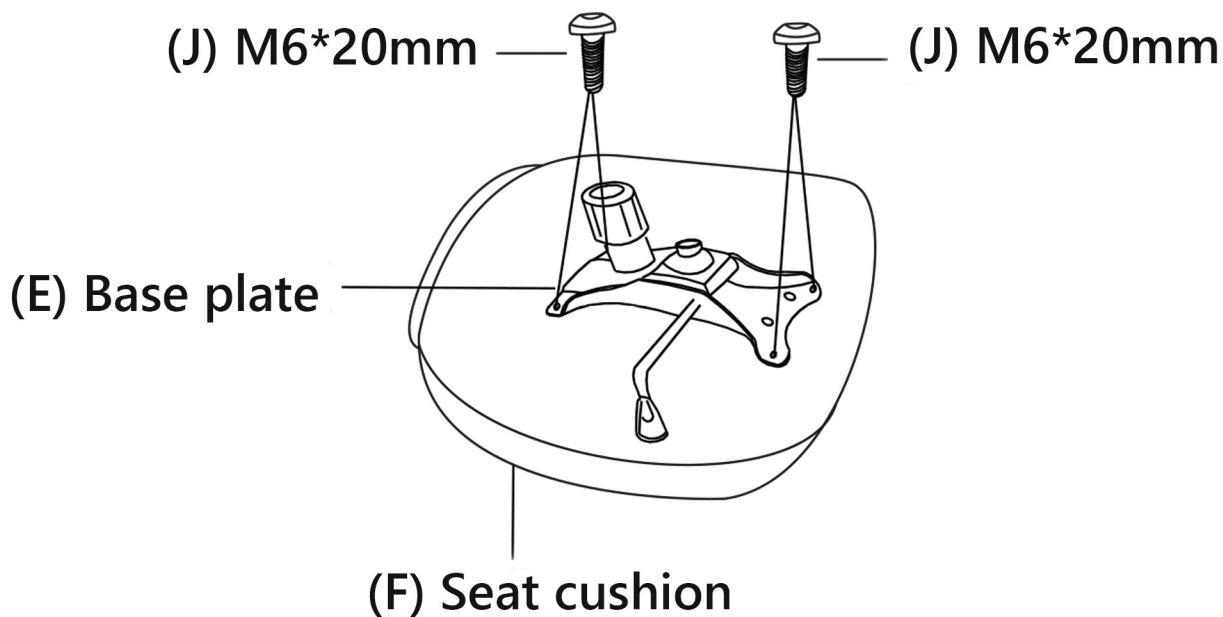

### Step 4

Align the air rod (C) with the hole in the middle of the base plate (E), then place the seat cushion (F) on the air rod (C), and press the seat cushion (F) from the top down to fix on.

(F) Seat cushion

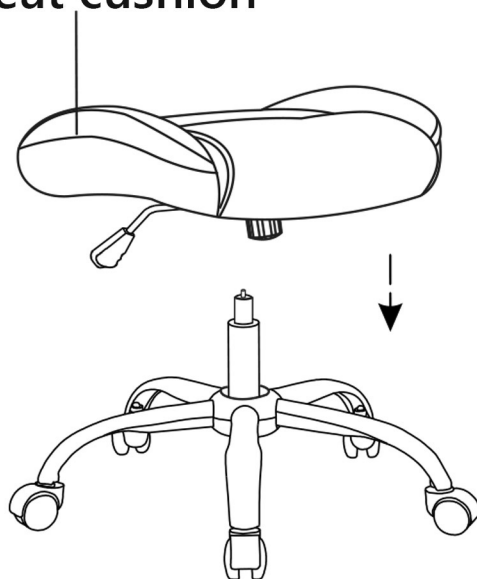

## Step 5

Attach the armrest frame (H) to the seat cushion (F) using 4 M6\*25 screws (K), and cover the screws (K) with the screw caps (L).

(H) Armrest frame

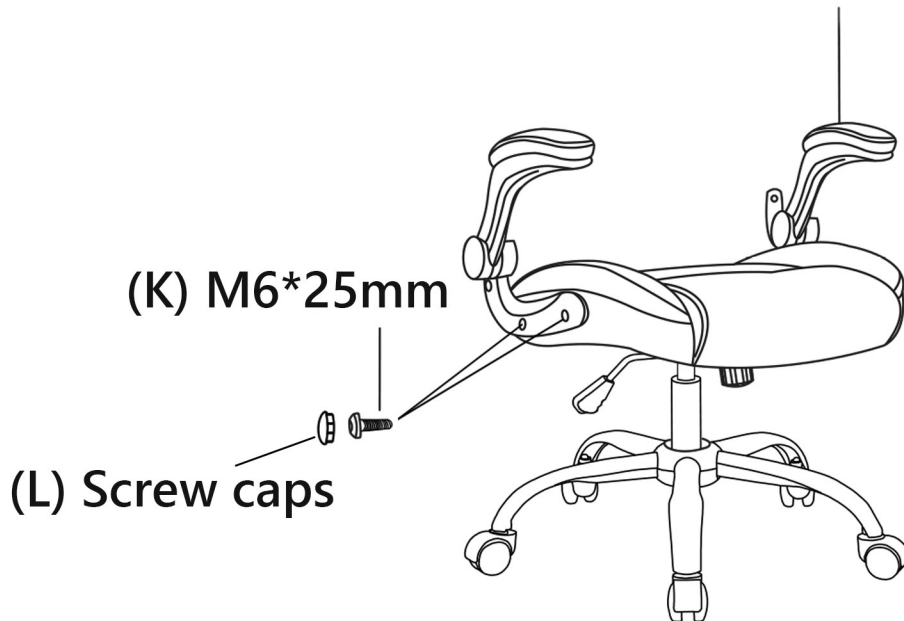

## Step 6

Attach the backrest (G) to the seat cushion (F) using 4 M6\*25 screws (K), and cover the screws (K) with the screw caps (M).

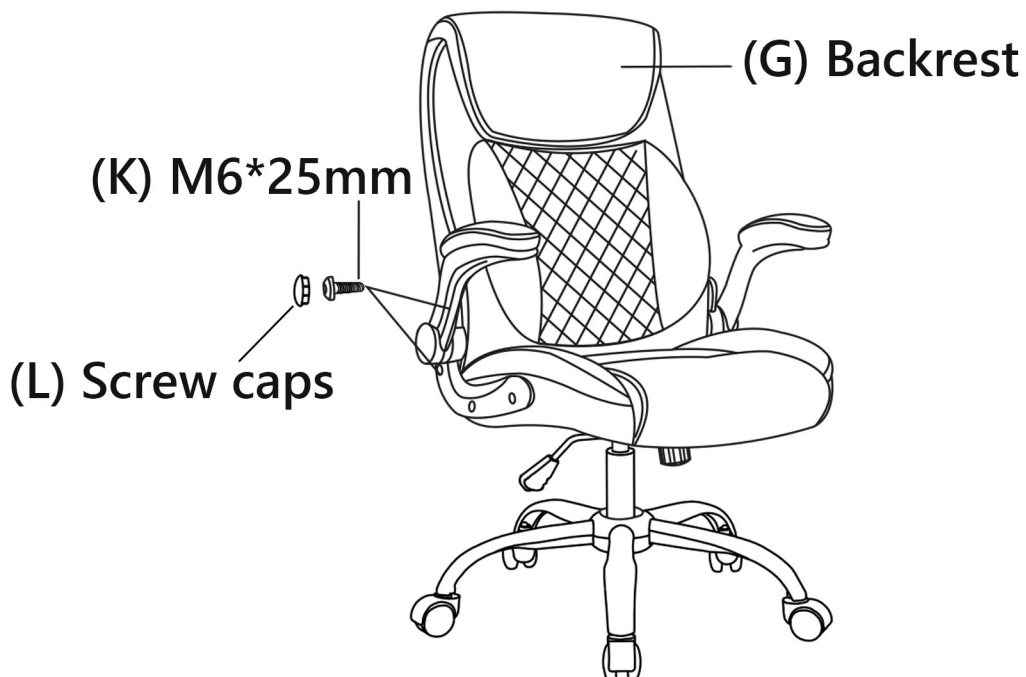

## Step 7

Done!

Please not exceed maximum load 350lbs.



# Instructions for Use



**Upward Adjustment**



**Downward Adjustment**

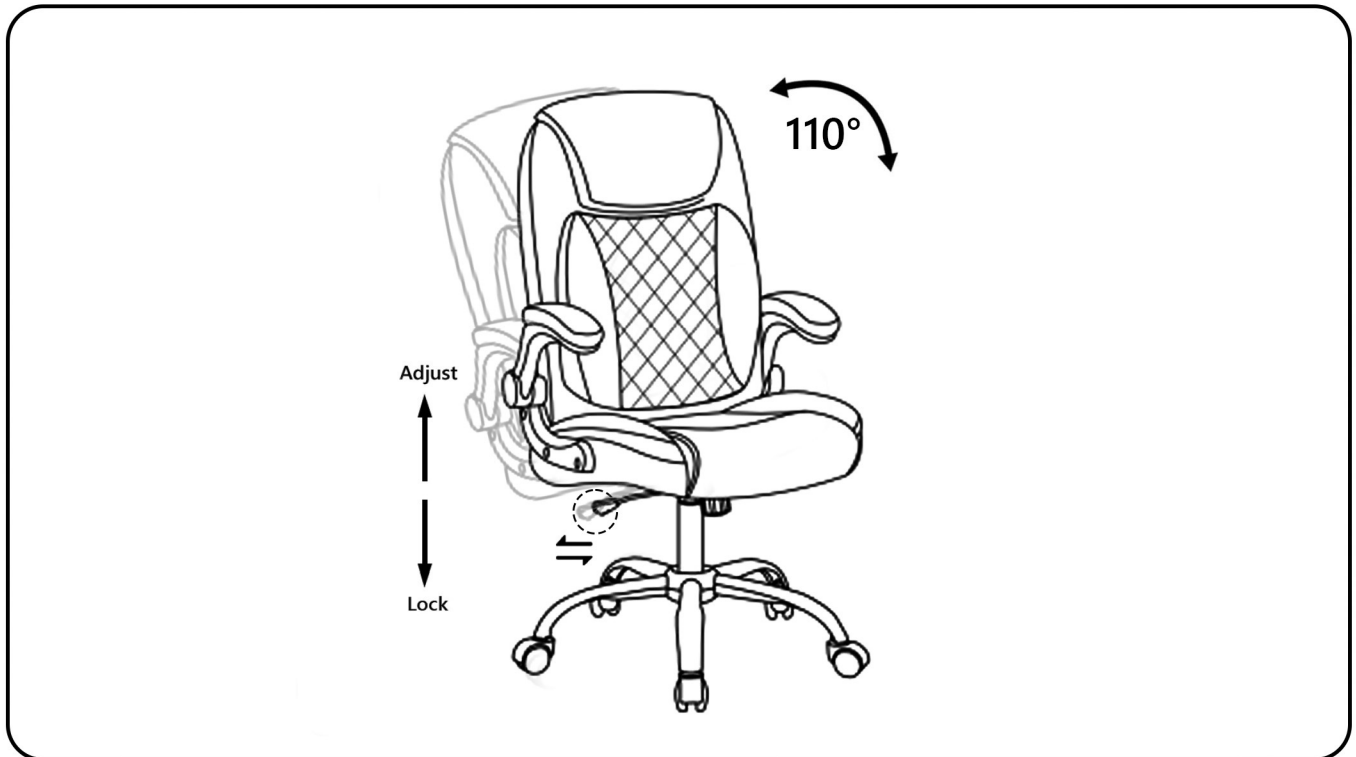

**Backrest Adjustment**