

Attention: Don't tighten the allen bolt before all allen bolt in place

USER'S MANUAL

Round Table

BEFORE YOU GET STARTED, A FEW POINTS



Having a friend to help makes assembly extra-easy



Mind the important safety information

★ PLEASE MAKE SURE ALL THE PARTS ARE INCLUDED.

1

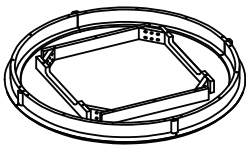

*1

Table top

2



*4

Table legs

3

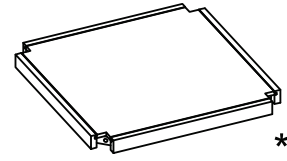

*1

Table shelf

A

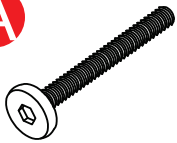

Ø5/16"x70mm
(12pcs)

B



Ø5/16"
(12pcs)

C



Ø5/16"
(12pcs)

D



M4 Allen Key
(1pc)

ASSEMBLY INSTRUCTIONS - ATTENTION

STEP 1

Assemble the Table Legs (2) to the Table Top (1), using Bolts (A), Spring washers (B) and Flat washers (C) by using Allen wrench (D).

Friendly notice:

If the rotation positions cannot be aligned well, gently shake the Table legs (2) when locking the Screws, this can help avoid jammed operations and poor installation. Don't tighten the Screw completely, just 50% is enough.

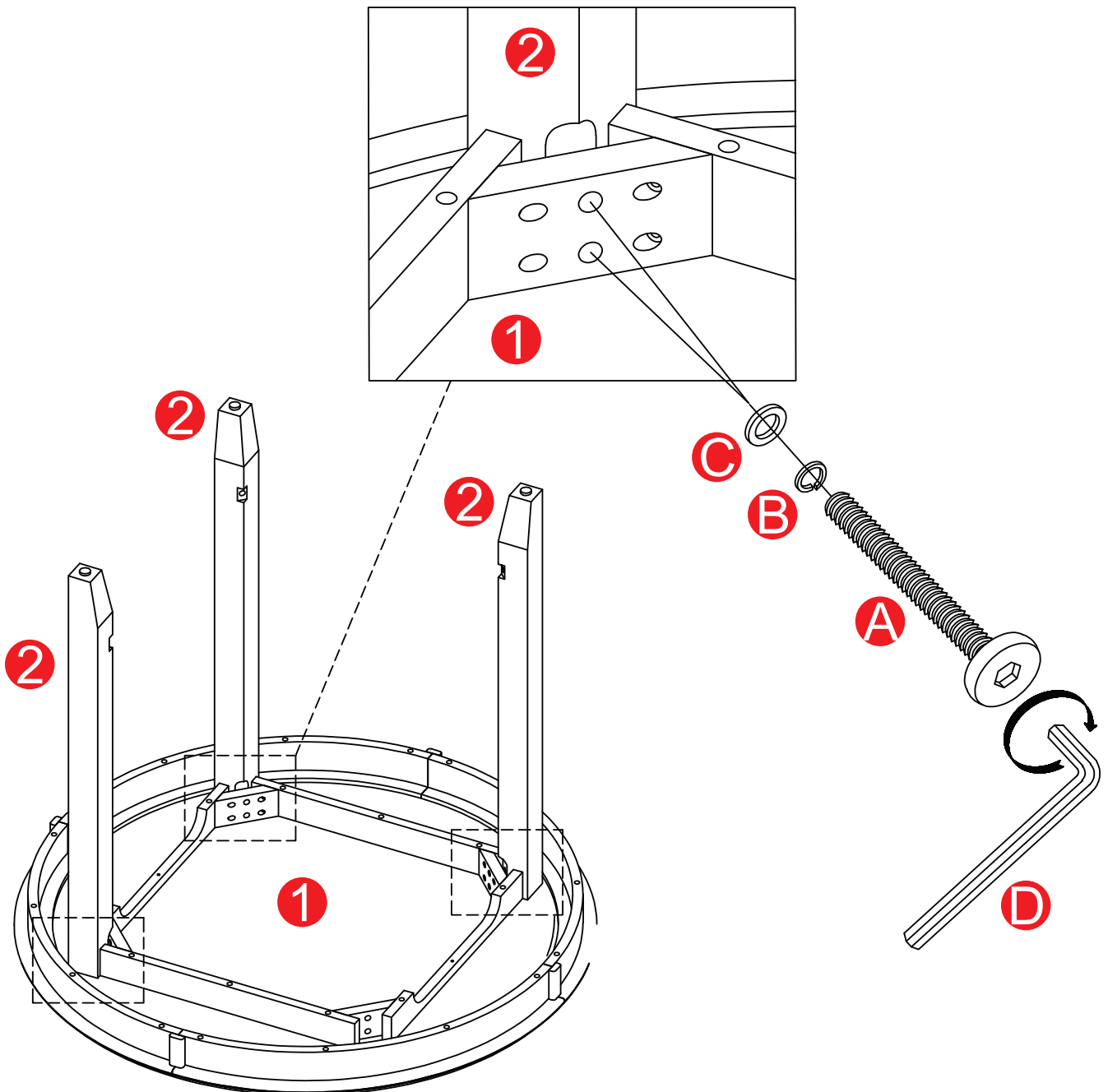

ASSEMBLY INSTRUCTIONS - ATTENTION

STEP 2

Assemble the Table Shelf (3) to the Table Leg (2), using the Bolt (A), Spring washers (B) and Flat washers (C) by using Allen wrench (D) . Do not over-tighten them, just tighten them to 50%.

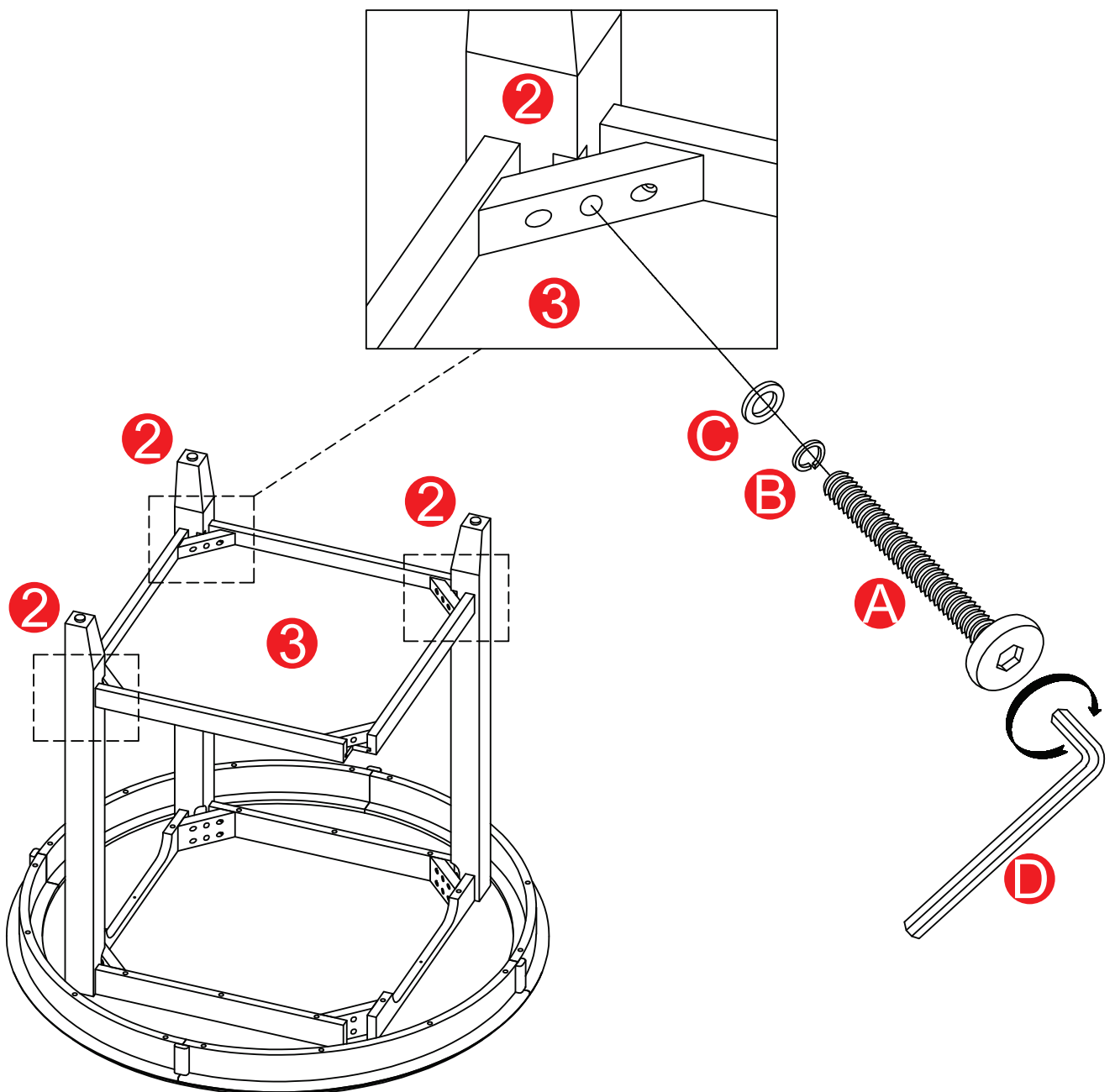

ASSEMBLY INSTRUCTIONS - ATTENTION

STEP 3

Assemble the Table Legs (2) to the Table Top (1) and Table Shelf (3), using Bolts (A), Spring Washers (B), and Flat Washers (C) using Allen wrenches (D). After adjust the balance of the entire table then tighten all bolts to 100%.

Stand your table, your table is ready to use.
This table can only be used on a flat, level surface.

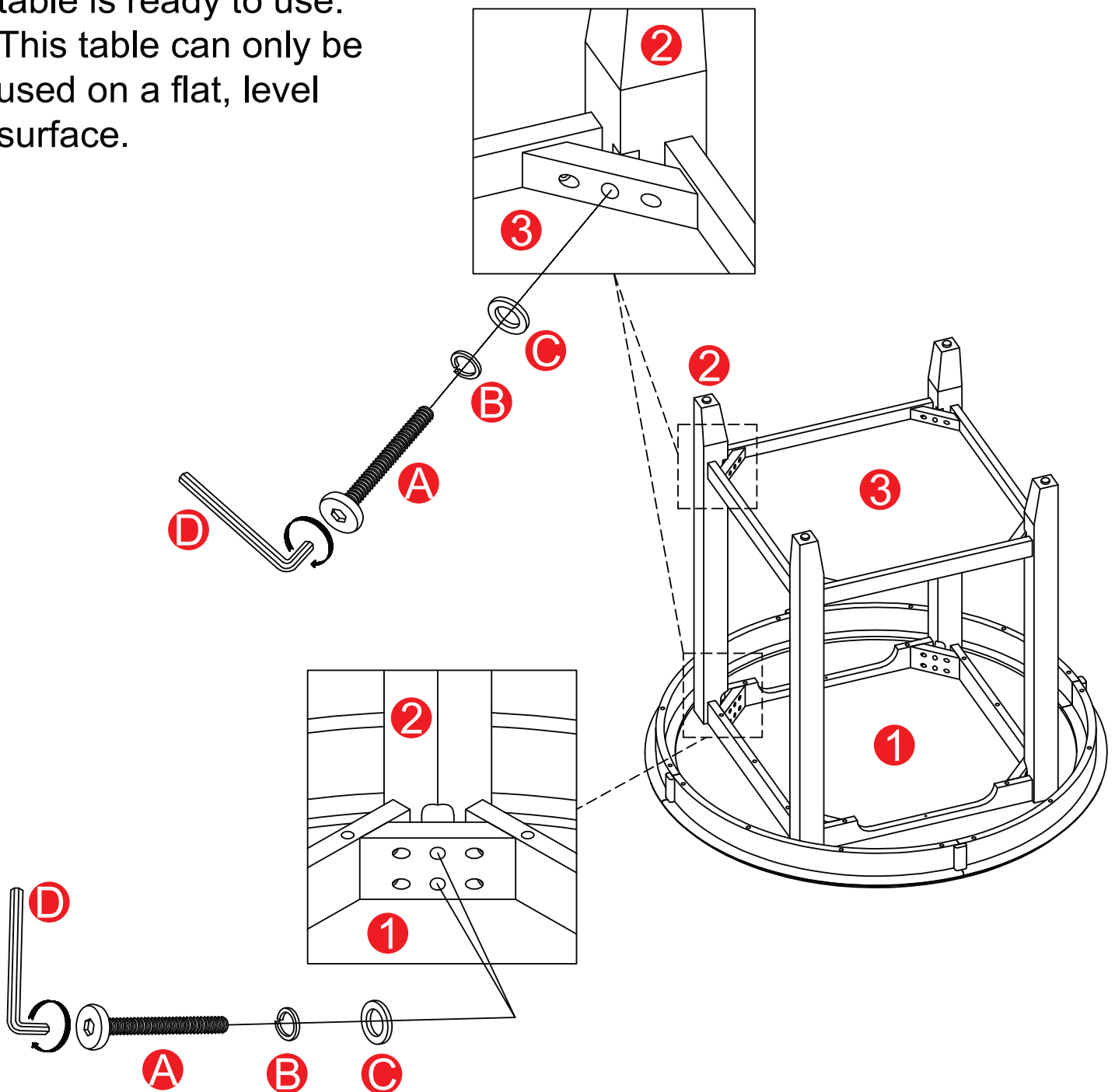

ASSEMBLY INSTRUCTIONS - ATTENTION

Please read the following instructions to help you assemble the table faster.

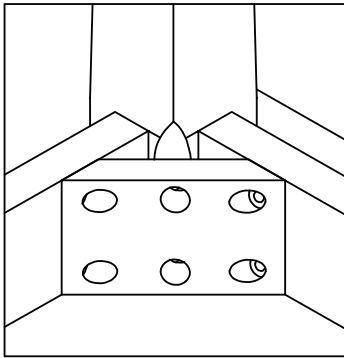

50%
↻

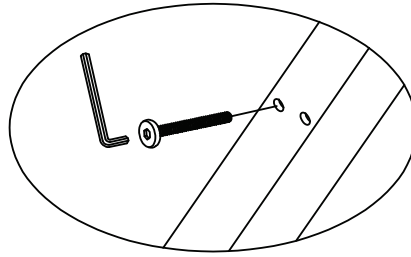

1. Partly screw in bolts, but do not fully tighten.

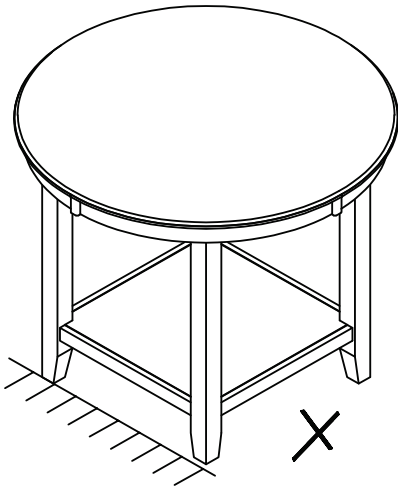

Apply pressure on the seat. (About 80lbs)

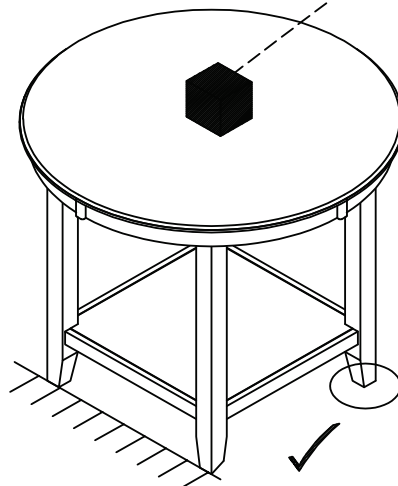
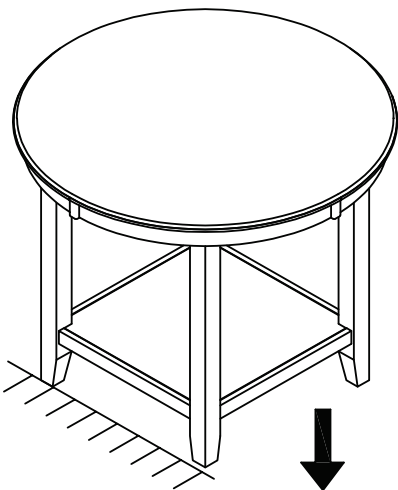

50%
↻

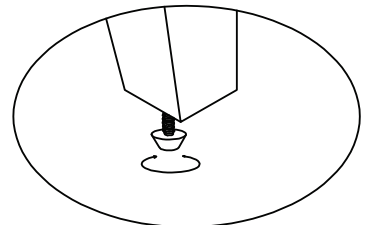

2. If your feet are not flat, you can also adjust the adjustable levelers on the bottom of the feet to improve the balance.



WARNING:



Read the instructions carefully.



Please follow the assembly steps.

Weight Capacity for Seating: 400LBS

To ensure proper assembly, follow all steps and use all parts, do not use power tools. Failure to follow this warning can result in serious injury to yourself or others.

Please inspect all items before assembly, if for any reason you need to return this item, please kindly return in it's original packaging.

To avoid misalignments, leave the bolts loose and do not tighten them until all are in their respective places.

Do not tighten all bolts completely until the entire unit has been assembled and set up.

Do not overtighten or force the bolts as they could break, strip, or damage the threads of the holes.

Using the wrong size of bolts on a part could result in damage to the bolts or the part.

Lubricate all moving parts and tighten all bolts every 6 month or whenever needed.

Do not use if this product become damaged, and / or components are broken or missing.