

COUNTER TABLE ASSEMBLY INSTRUCTION

Thank you for purchasing this quality product. Be sure to check all packing material carefully for small parts which may have come loose inside the carton during shipment. Separate, identify and count all parts and hardware. Compare with the parts list to be sure all parts are present.

IMPORTANT : PLEASE READ INSTRUCTION BEFORE STARTING THE ASSEMBLY.

"DO NOT TIGHTEN SCREWS UNTIL COMPLETELY ASSEMBLED"

"DO NOT OVERTIGHT ANY HARDWARE"

WARNING : SMALL PARTS AND HARDWARE NOT FOR CHILDREN UNDER 3 YEARS. ADULT ASSEMBLY REQUIRED.

TABLE OF CONTENTS

HARDWARES LIST	PAGE 2
PARTS LIST	PAGE 3-4
PARTS' LOCATION	PAGE 5
ASSEMBLY STEPS	PAGE 6-10
ASSEMBLY COMPLETED	PAGE 10

ASSEMBLY TOOLS REQUIRED

1. Screwdriver (not provide)

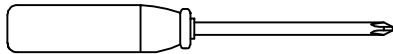

2. Hammer (not provide)

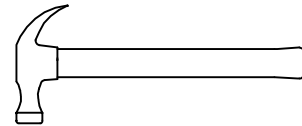



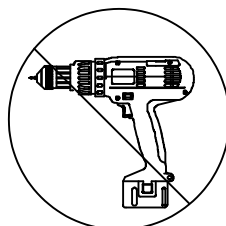





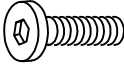







Skip the power drill this time.



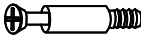

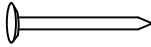
COUNTER TABLE ASSEMBLY INSTRUCTION

HARDWARES LIST

ITEM	DESCRIPTION	DRAWING	QTY
A	JCBC SCREW M6 x 15MM		16 PCS
B	JCBC SCREW M6 x 30MM		6 PCS
C	JCBC SCREW M6 x 45MM (BLACK)		6 PCS
D	JCBB SCREW M8 x 70MM		8 PCS
E	SPRING WASHER M6 x 12MM		6 PCS
F	FLAT WASHER M6 x 19MM		6 PCS
G	SPRING WASHER M6 x 12MM (BLACK)		6 PCS
H	FLAT WASHER M6 x 19MM (BLACK)		6 PCS
I	SPRING WASHER M8 x 13MM		8 PCS
J	FLAT WASHER M8 x 22MM		8 PCS
K	WOOD DOWEL M8 x 30MM		2 PCS
L	MINI FIX CAM LOCK		6 PCS
M	MINI FIX CAM BOLT		6 PCS
N	SHELF SUPPORT 5 x 15MM		4 PCS
O	NAIL 3/4 x 17MM BWG		14 PCS
P	M4 ALLEN KEY (100MM)		1 PC
Q	M5 ALLEN KEY (65MM)		1 PC

COUNTER TABLE ASSEMBLY INSTRUCTION

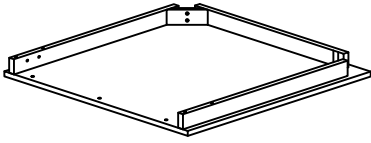
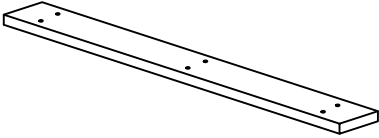
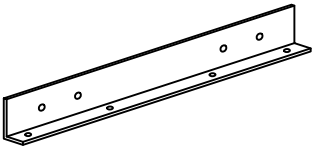
PARTS LIST

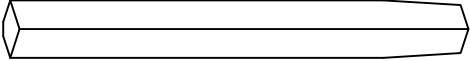
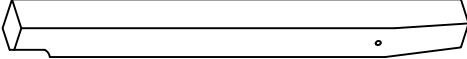
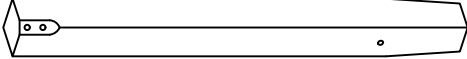
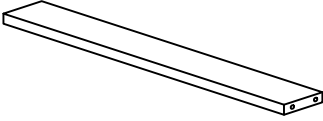
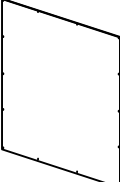
ITEM	DESCRIPTION	DRAWING	QTY
1	TABLE TOP		2 PCS
2	CENTER SUPPORT		1 PCS
3	SUPPORT SIDE RAIL		2 PCS
4	TABLE LEG WITH LABEL "4"		1 PC
5	TABLE LEG WITH LABEL "5"		1 PC
6	TABLE LEG WITH LABEL "6"		1 PC
7	TABLE LEG WITH LABEL "7"		1 PC
8	SIDE PANEL SUPPORT		1 PC
9	BACK PANEL		1 PC

COUNTER TABLE ASSEMBLY INSTRUCTION

PARTS LIST

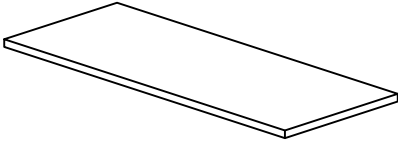
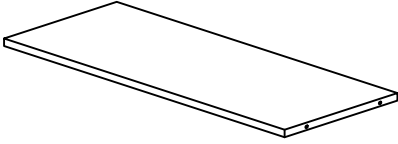
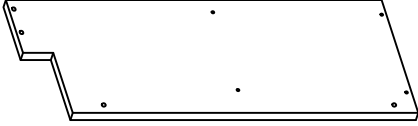
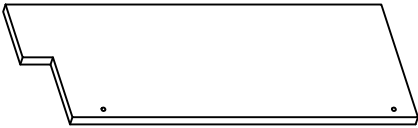
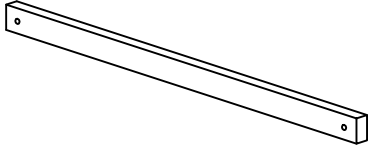
ITEM	DESCRIPTION	DRAWING	QTY
10	SHELF PANEL		1 PC
11	BOTTOM PANEL		1 PC
12	SIDE PANEL WITH LABEL "L"		1 PC
13	SIDE PANEL WITH LABEL "R"		1 PC
14	TABLE LEG SUPPORT		1 PC

COUNTER TABLE ASSEMBLY INSTRUCTION

PARTS ' LOCATION

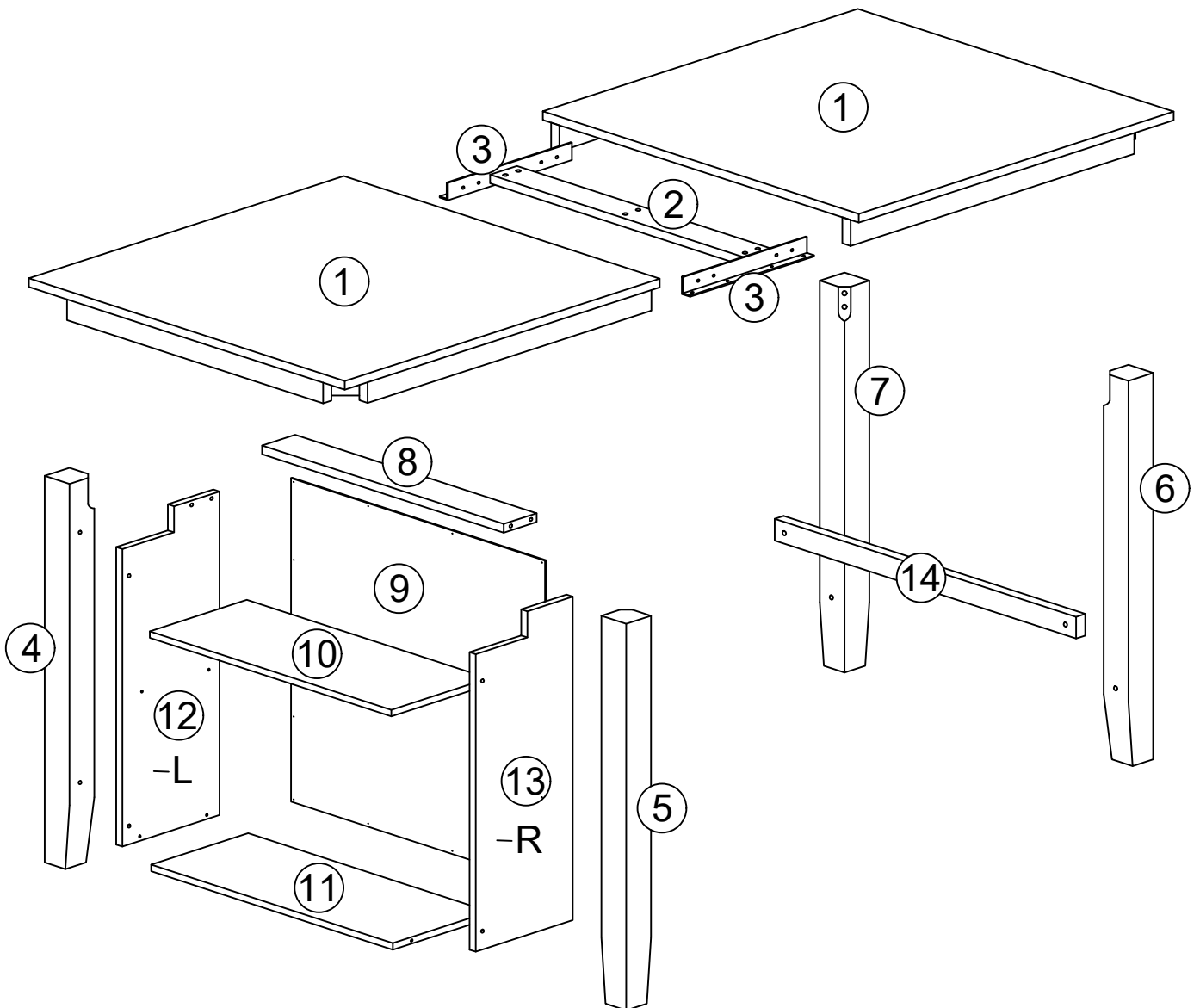

COUNTER TABLE ASSEMBLY INSTRUCTION

STEP 1

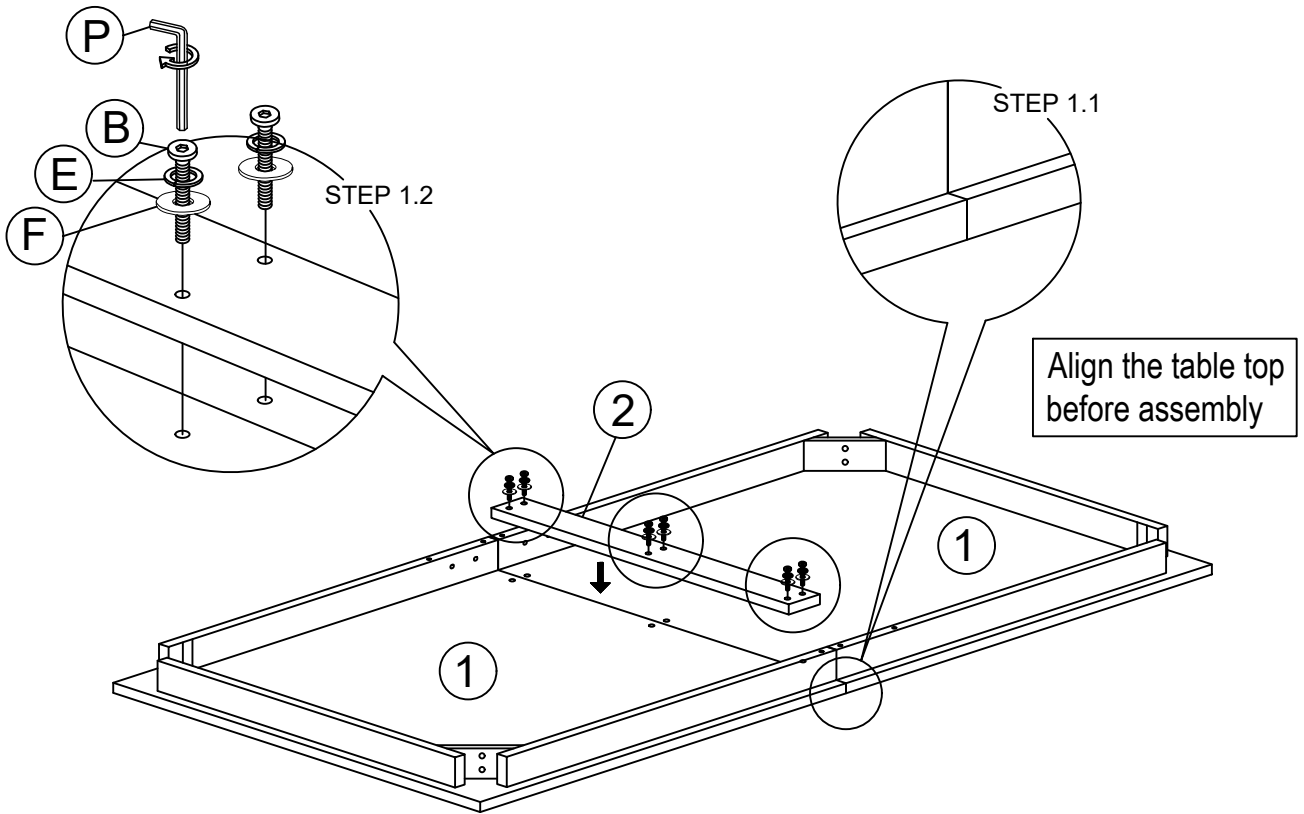

STEP 2

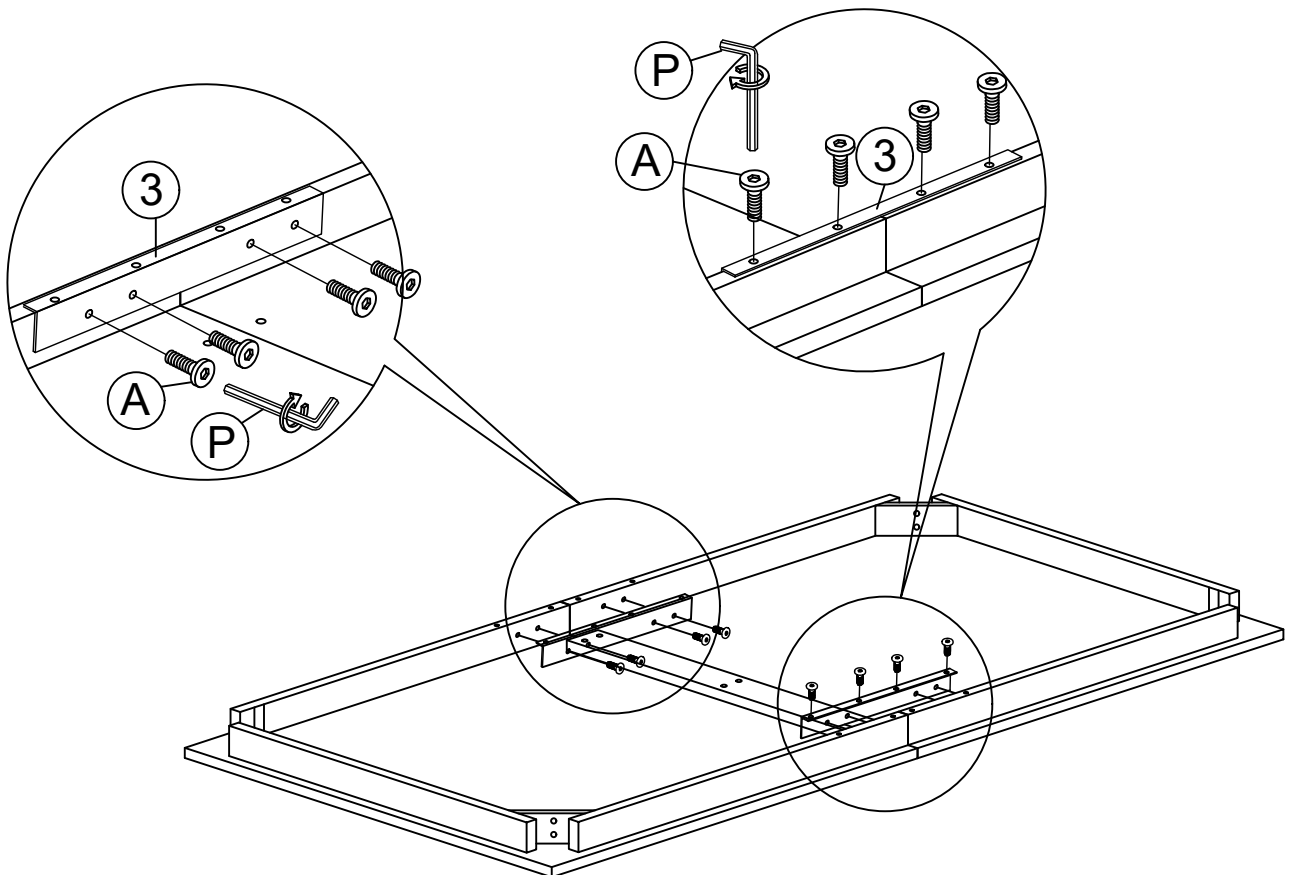

COUNTER TABLE ASSEMBLY INSTRUCTION

STEP 3

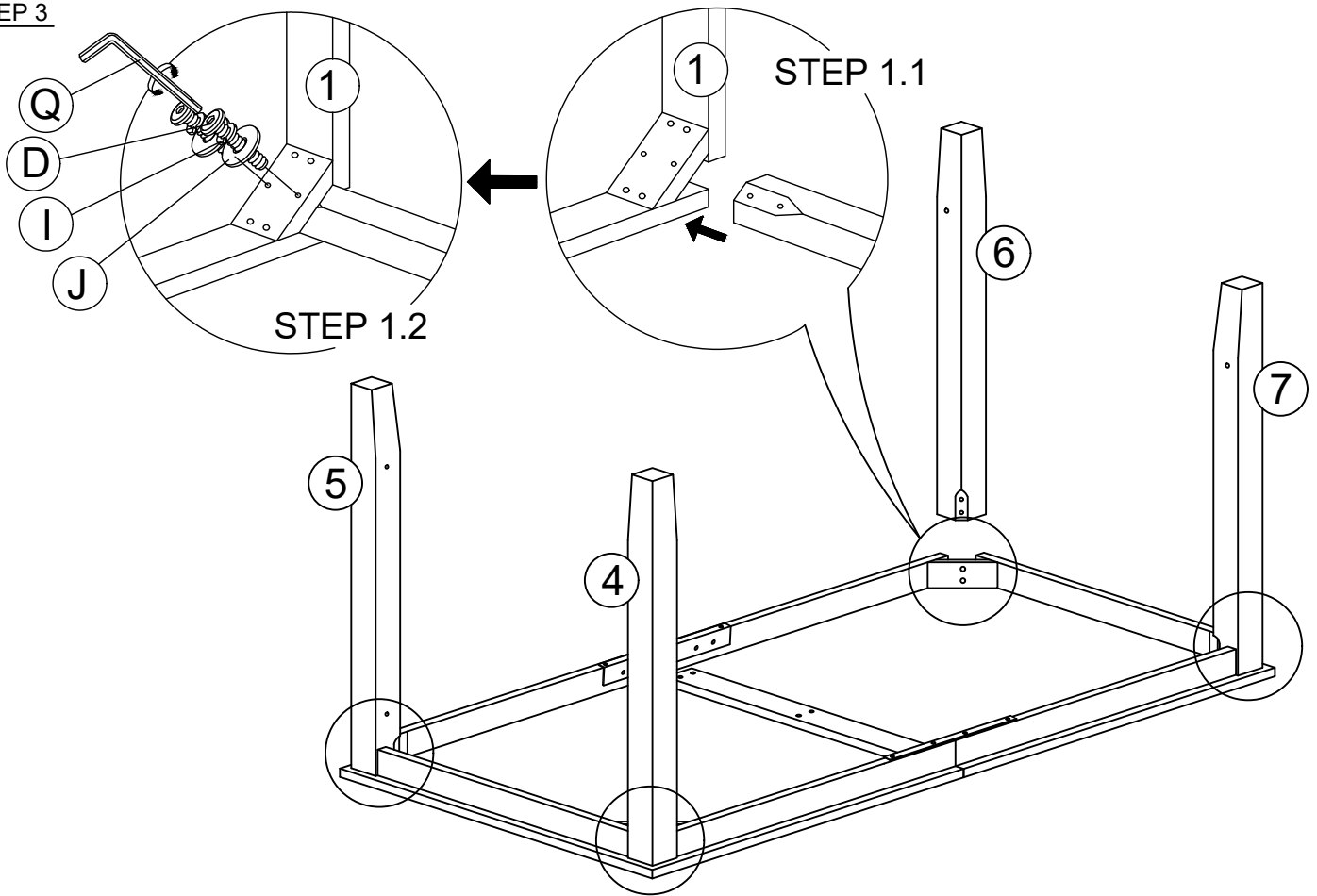

STEP 4

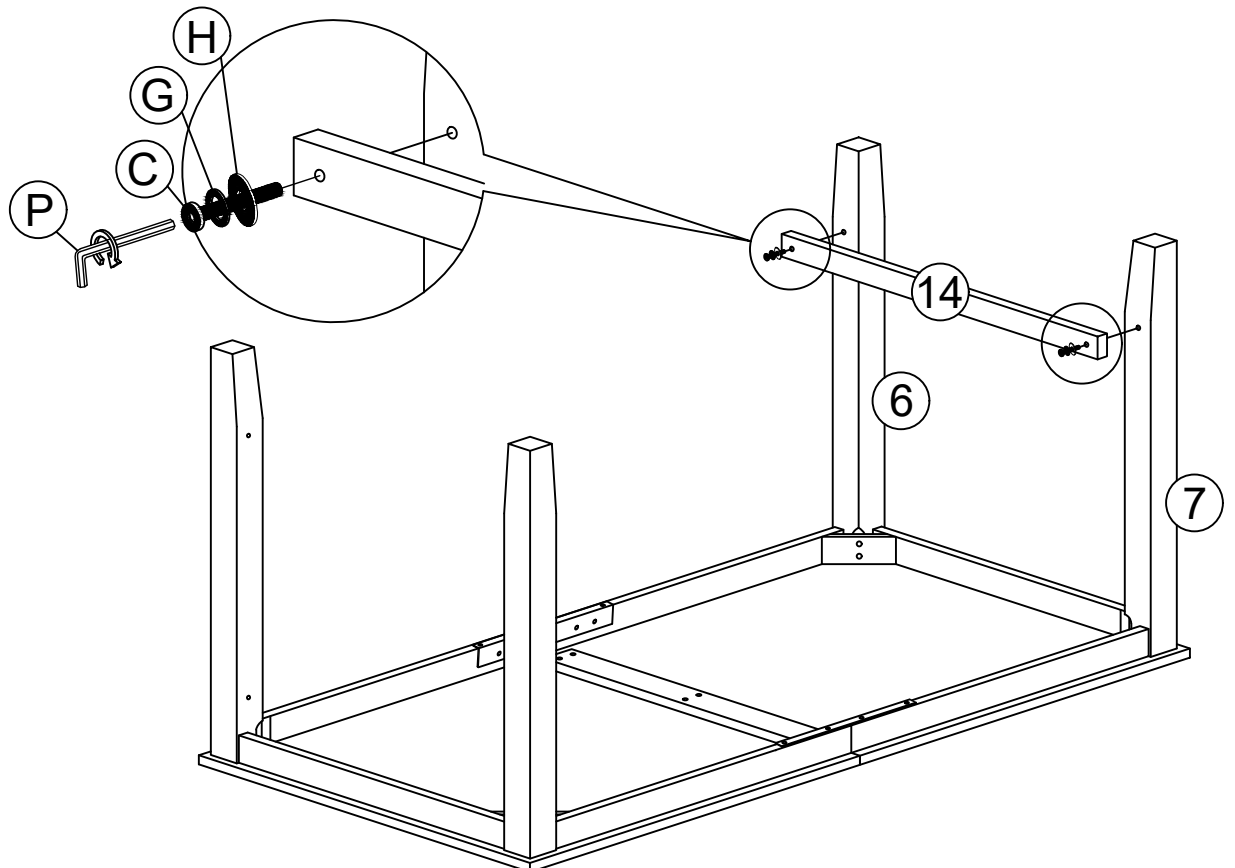

COUNTER TABLE ASSEMBLY INSTRUCTION

STEP 5

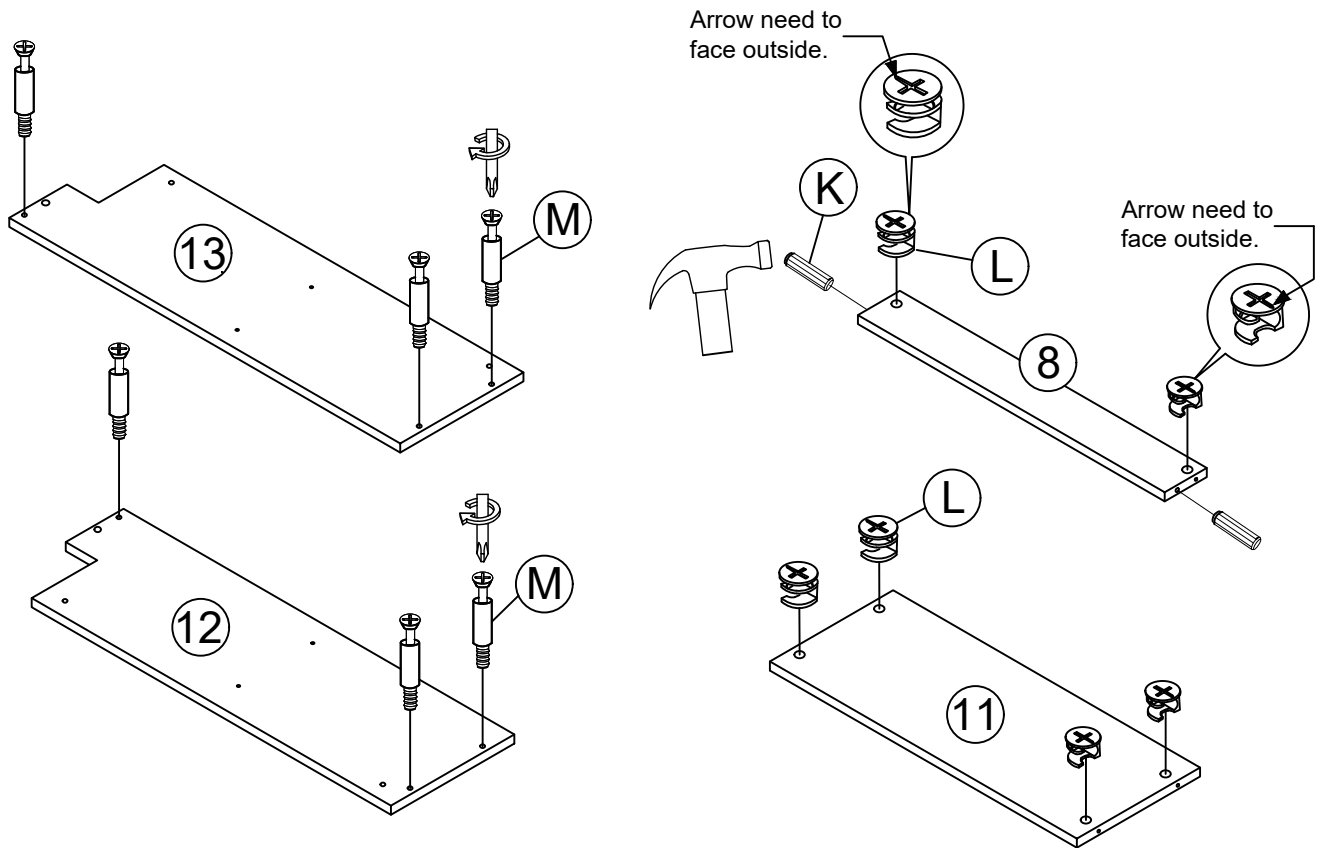

STEP 6

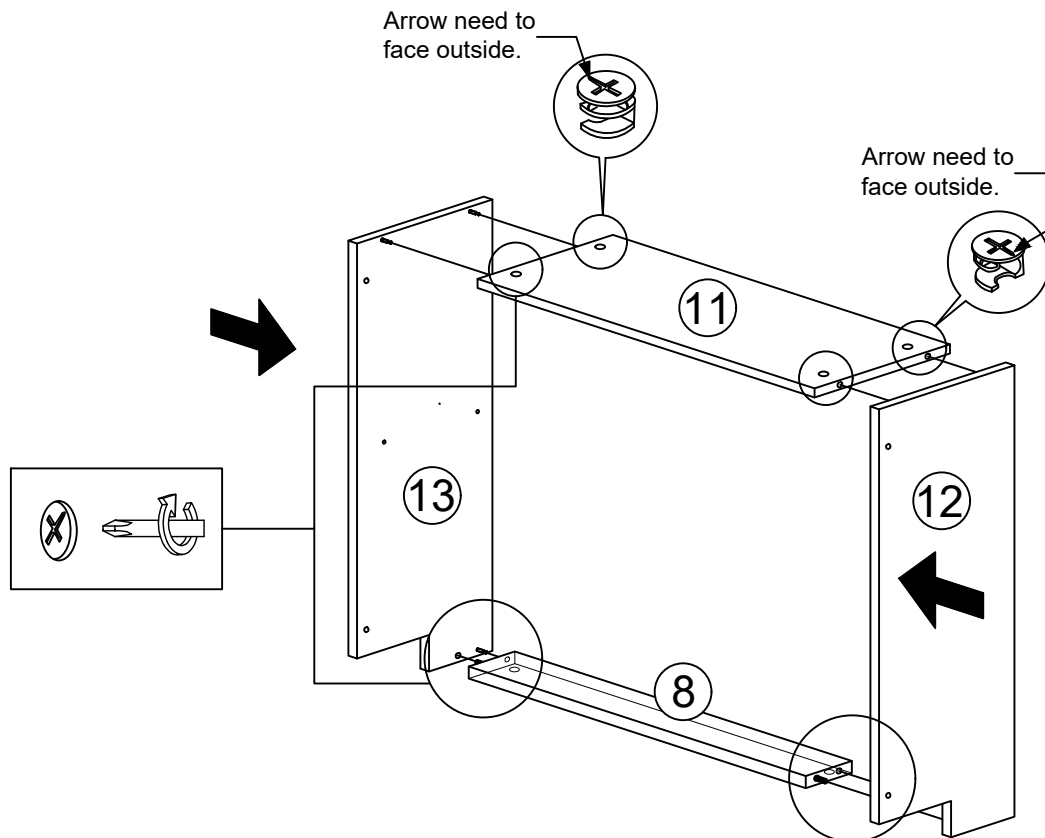

COUNTER TABLE ASSEMBLY INSTRUCTION

STEP 7

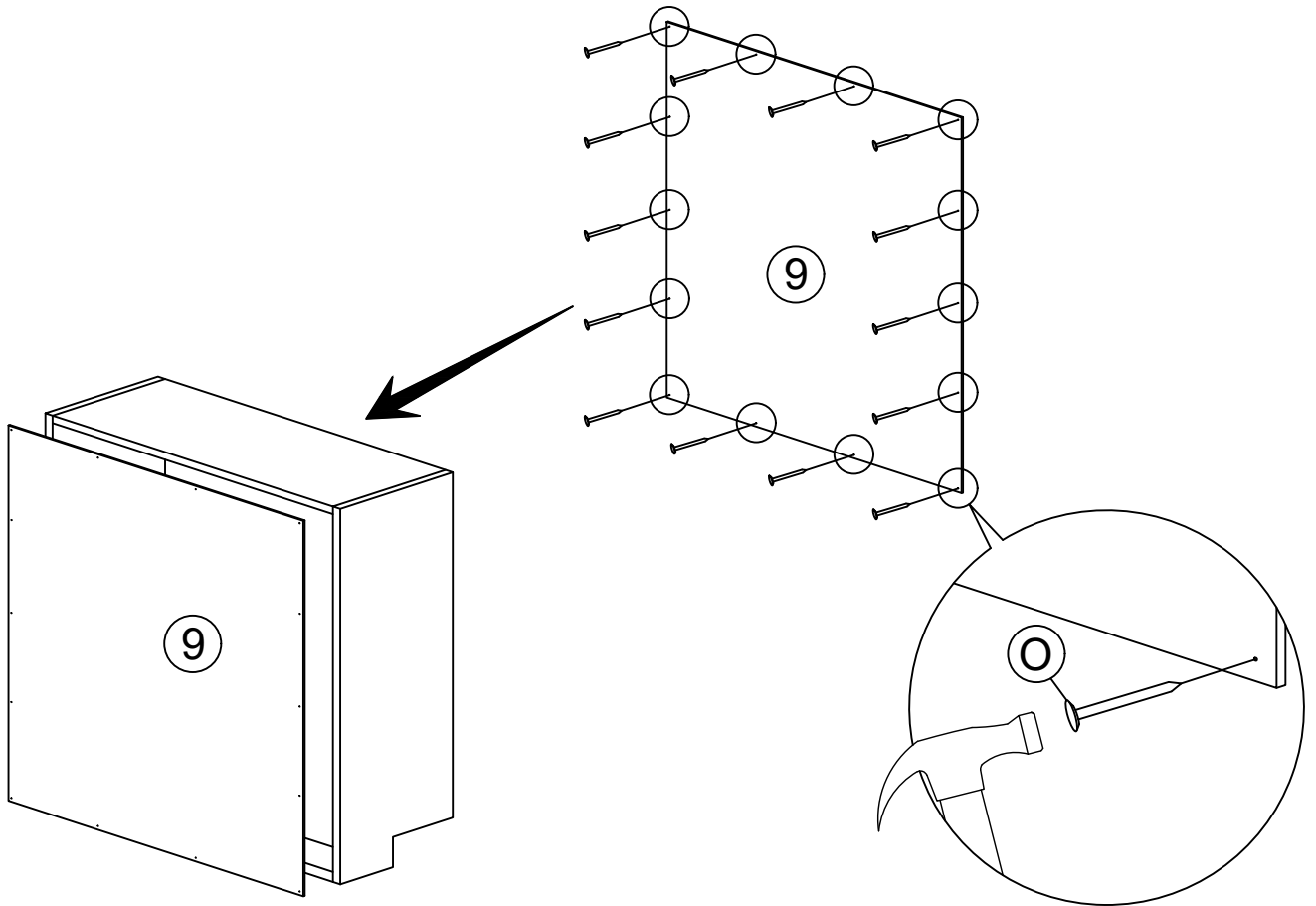

STEP 8

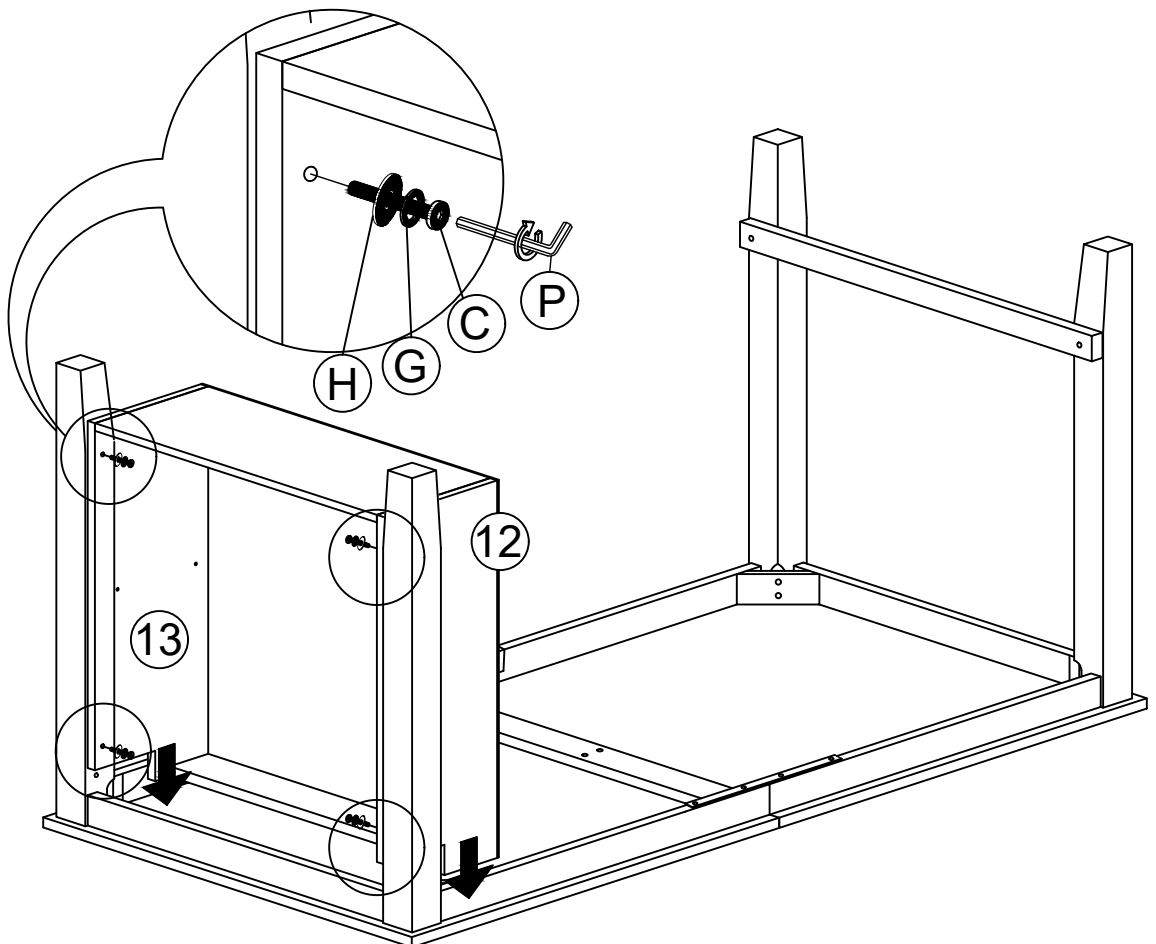

COUNTER TABLE ASSEMBLY INSTRUCTION

STEP 9

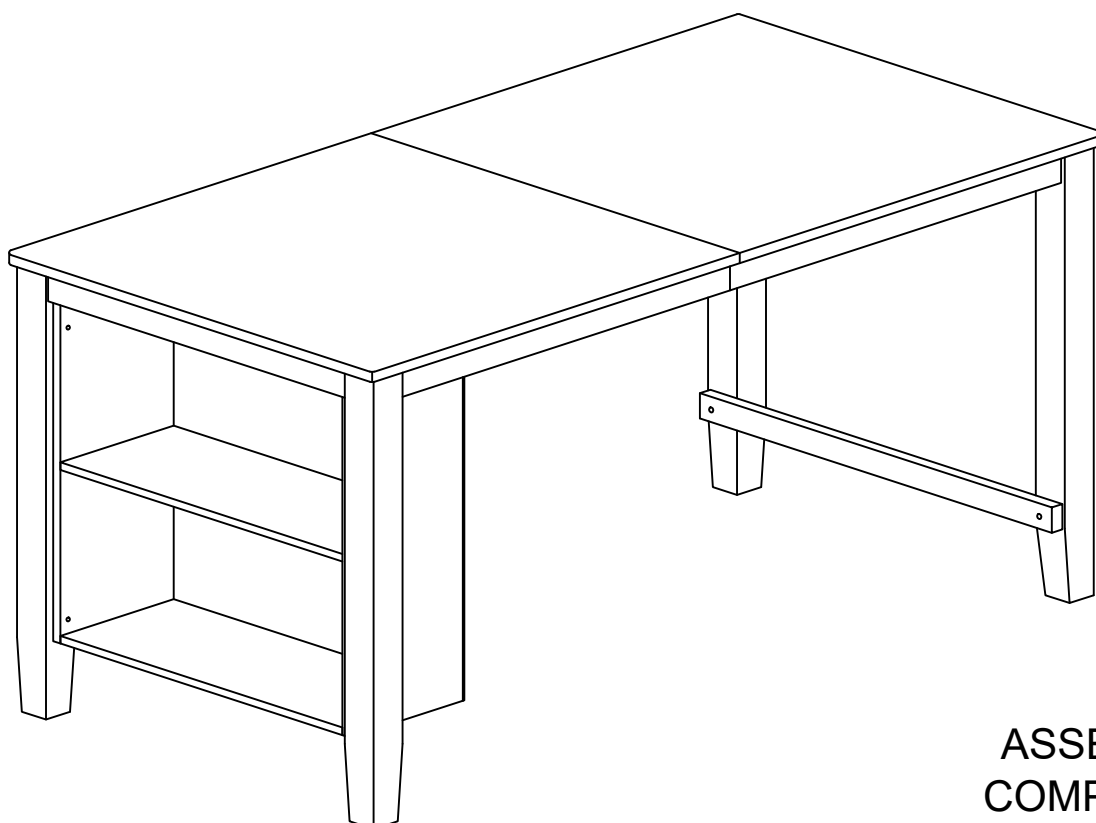
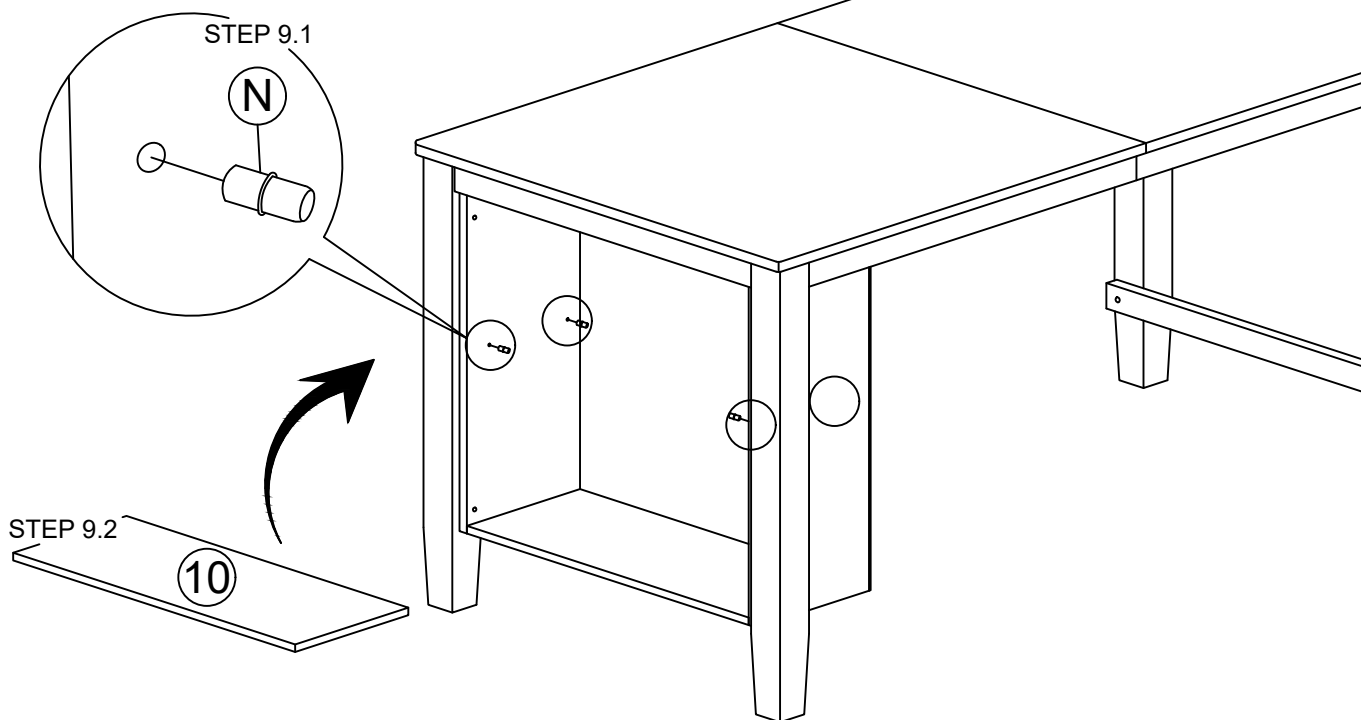

**ASSEMBLY
COMPLETED**