

Closet System with Shelves

Assembly Instructions

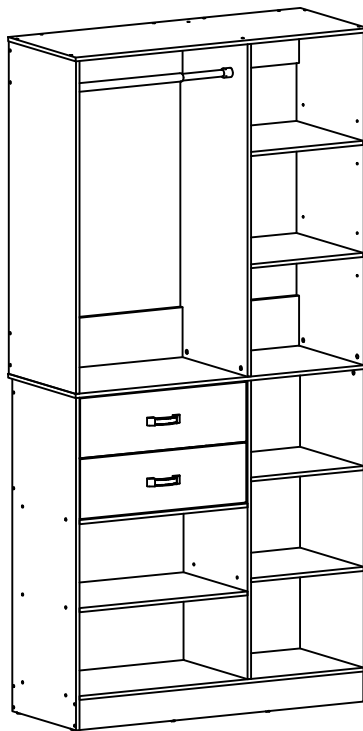





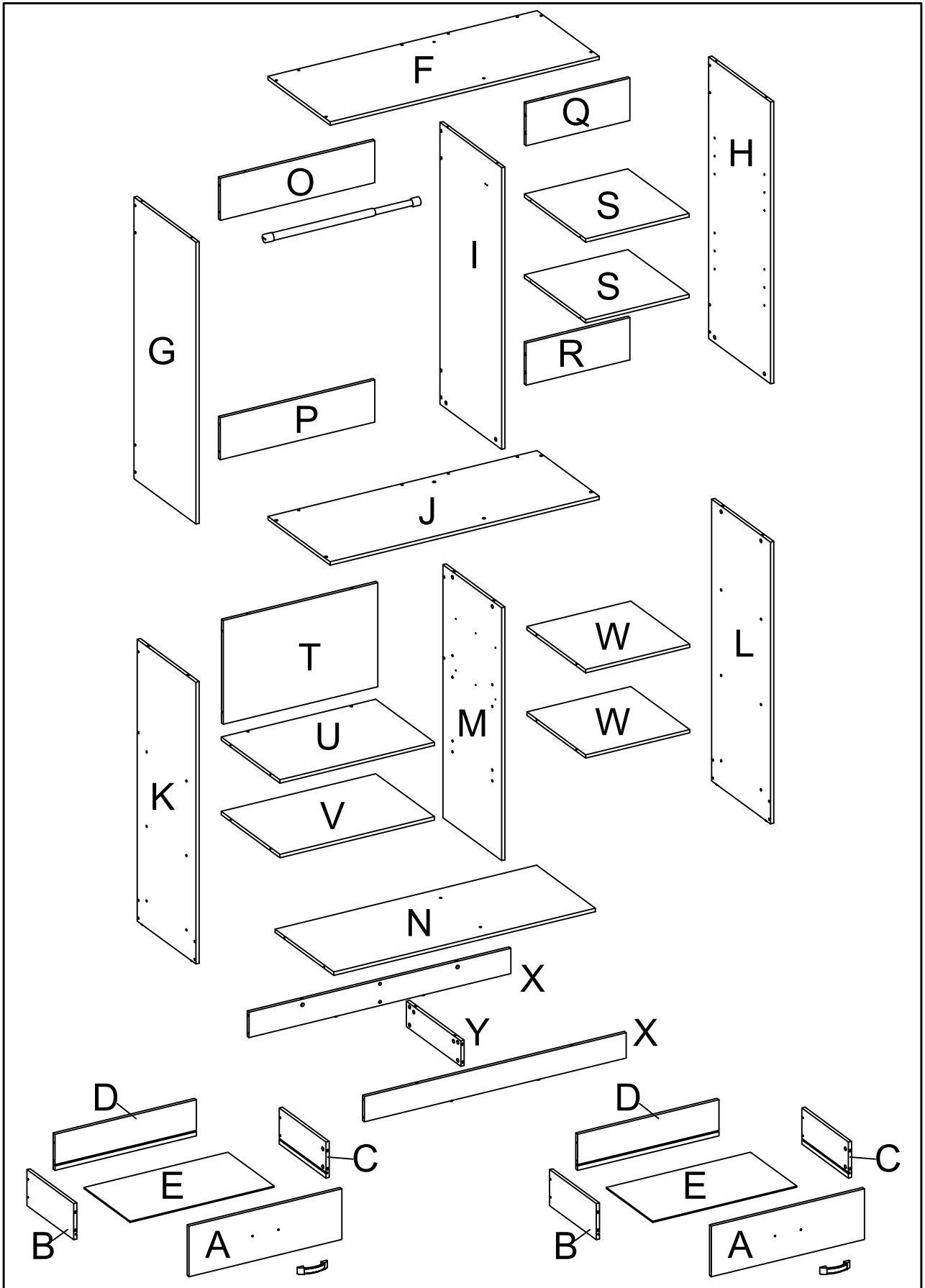

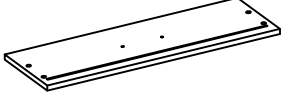
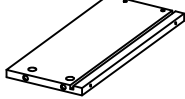
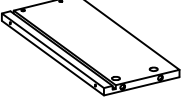

Attention: Please ensure you have all parts before commencing assembly.
Please read all the instructions before commencing.

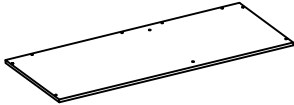

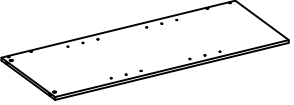

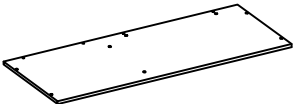
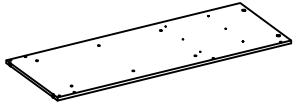
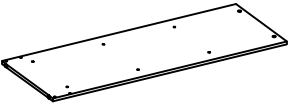
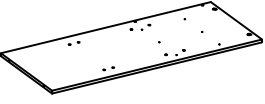
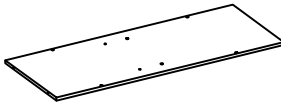
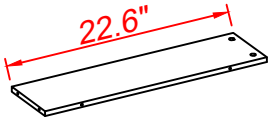
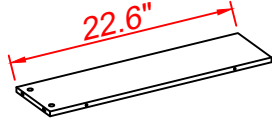
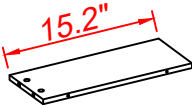
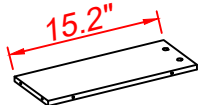
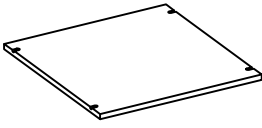
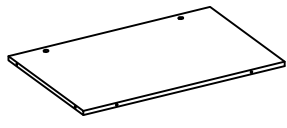
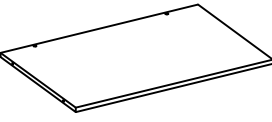
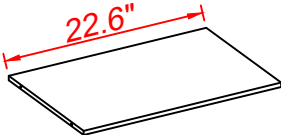
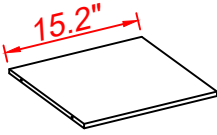
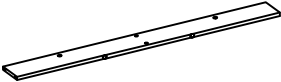





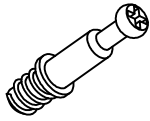

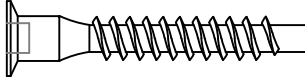

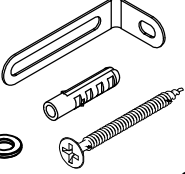
PART LIST



PART LIST

<p>A x 2pcs</p> 	<p>B x 2pcs</p> 	<p>C x 2pcs</p> 	<p>D x 2pcs</p> 
<p>E x 2pcs</p> 	<p>F x 1pc</p> 	<p>G x 1pc</p> 	<p>H x 1pc</p> 
<p>I x 1pc</p> 	<p>J x 1pc</p> 	<p>K x 1pc</p> 	<p>L x 1pc</p> 
<p>M x 1pc</p> 	<p>N x 1pc</p> 	<p>O x 1pc</p> 	<p>P x 1pc</p> 
<p>Q x 1pc</p> 	<p>R x 1pc</p> 	<p>S x 2pcs</p> 	<p>T x 1pc</p> 
<p>U x 1pc</p> 	<p>V x 1pc</p> 	<p>W x 2pcs</p> 	<p>X x 2pcs</p> 
<p>Y x 1pc</p> 			

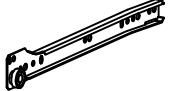
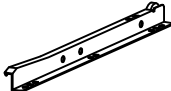
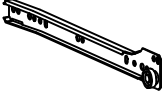
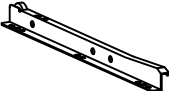
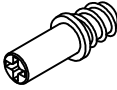
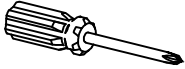
HARDWARE LIST

<p>①</p>  <p>M6x28 40 pcs</p>	<p>②</p>  <p>Ø12 40 pcs</p>	<p>③</p>  <p>M6x40 58 pcs</p>	<p>④</p>  <p>M4x30 8 pcs</p>
<p>⑤</p>  <p>M4x40 2 pcs</p>	<p>⑥</p>  <p>M3x12 24 pcs</p>	<p>⑦</p>  <p>2 pcs</p>	<p>⑧</p>  <p>M4x15 4 pcs</p>
<p>⑨</p>  <p>47-80cm 1 pc</p>	<p>⑩</p>  <p>1 pc</p>	<p>⑪</p>  <p>1 pc</p>	<p>⑫</p>  <p>M4x12 4 pcs</p>
<p>⑬</p>  <p>300L 2 pcs</p>	<p>⑭</p>  <p>300L 2 pcs</p>	<p>⑮</p>  <p>300L 2 pcs</p>	<p>⑯</p>  <p>300L 2 pcs</p>
<p>⑰</p>  <p>Ø6x20 8 pcs</p>	<p>⑱</p>  <p>1 pc</p>	<p>⑲</p>  <p>M4 1 pc</p>	

Please count and verify all parts before assembly .

How to install Camlocks

Connect the male camlock as directed in the assembly instructions with a screwdriver.

1 DO NOT OVER TIGHTEN

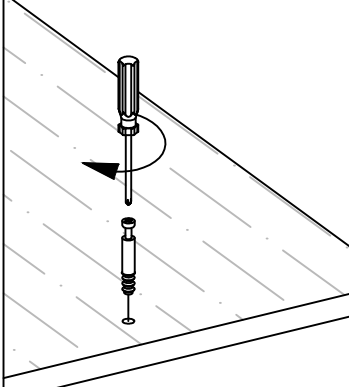

Put the male camlock into the entry hole.

2

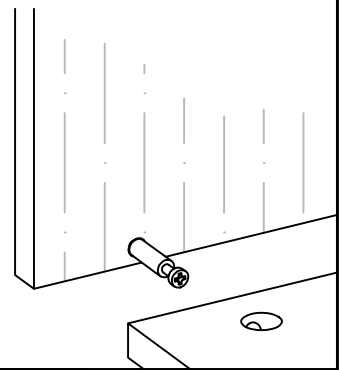

Insert the female camlock as shown in the instruction.

Note: ensure that the arrow on the top of the camlock points toward the entry hole for the male camlock.

3

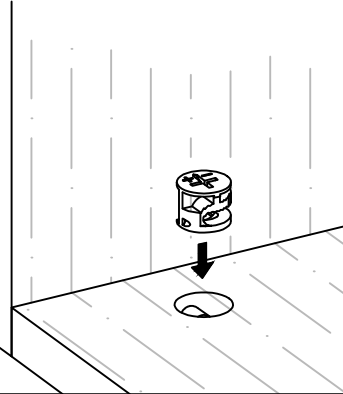

Screw the female camlock clockwise with a screwdriver.

You will feel a click when the camlock is locked in place.

The camlock is now completed.

4

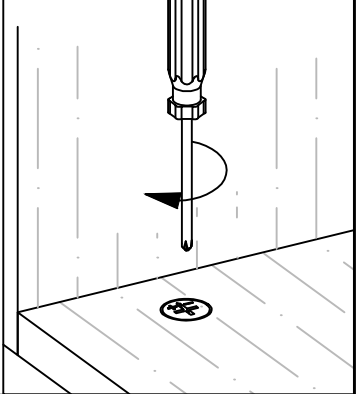

STEP 1

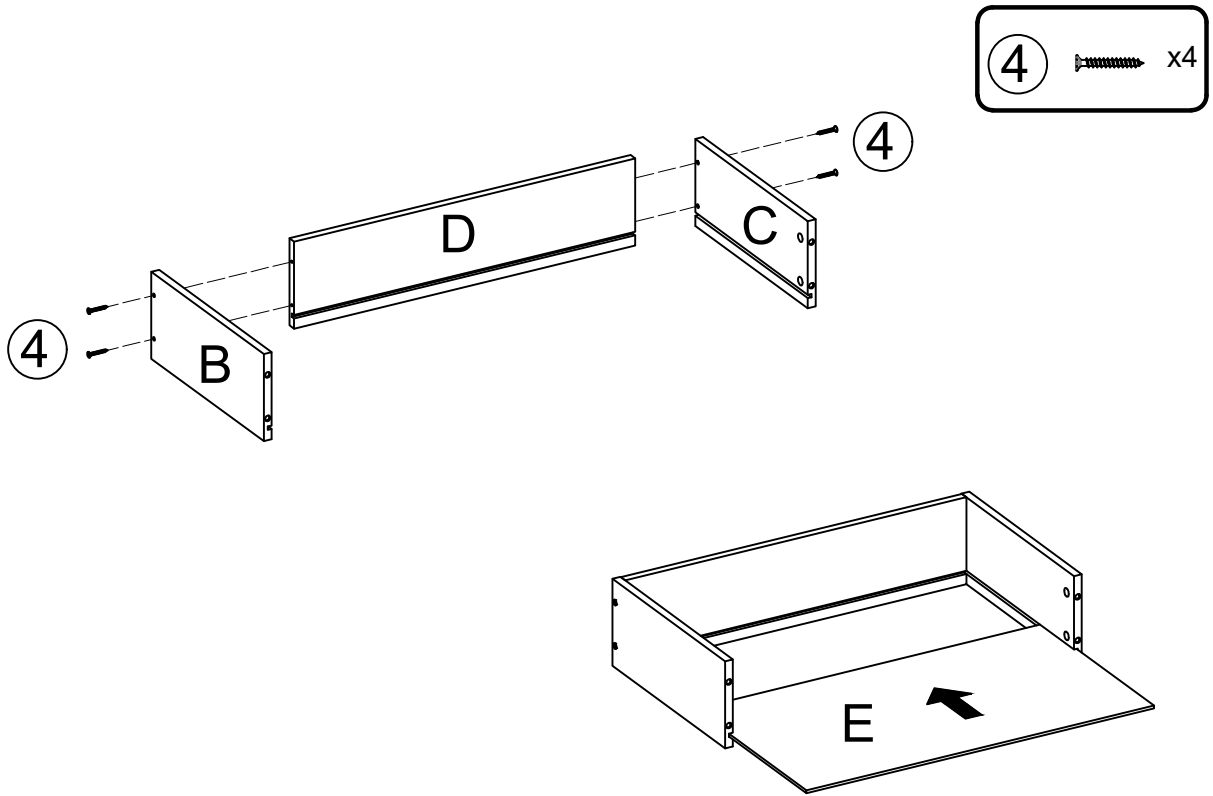

STEP 2

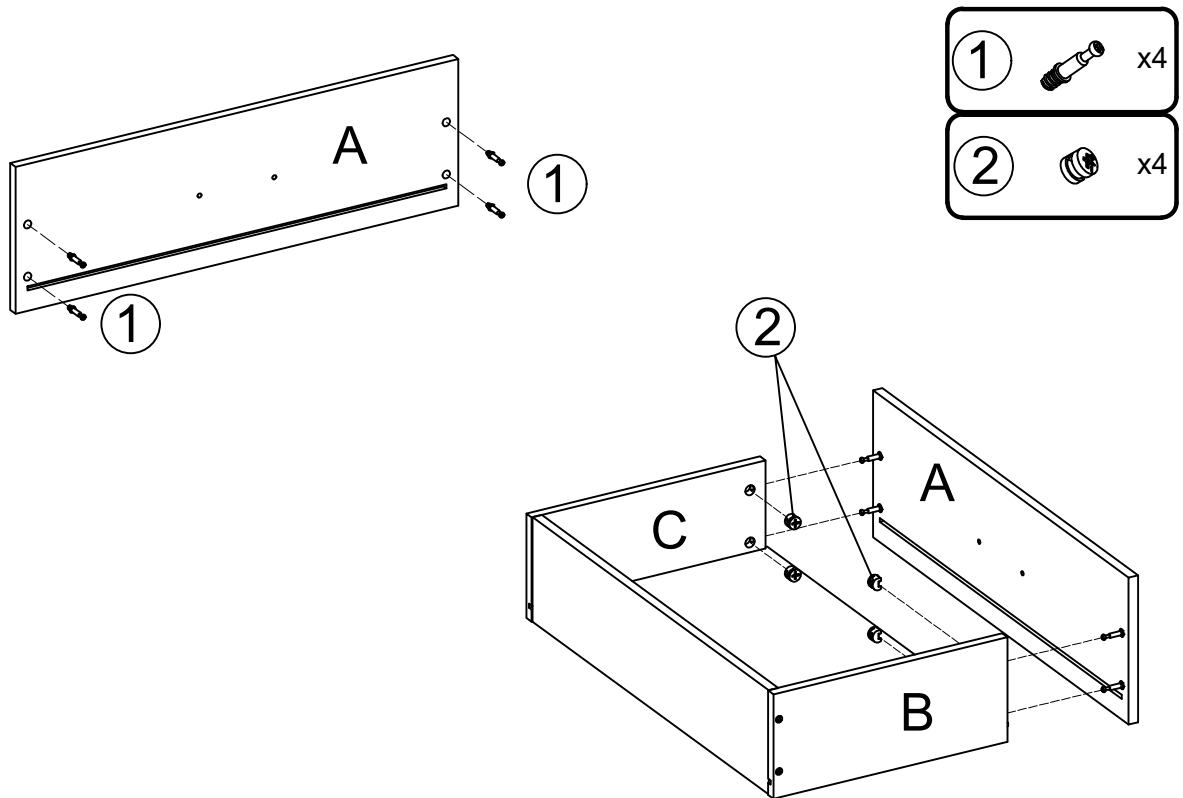

STEP 3

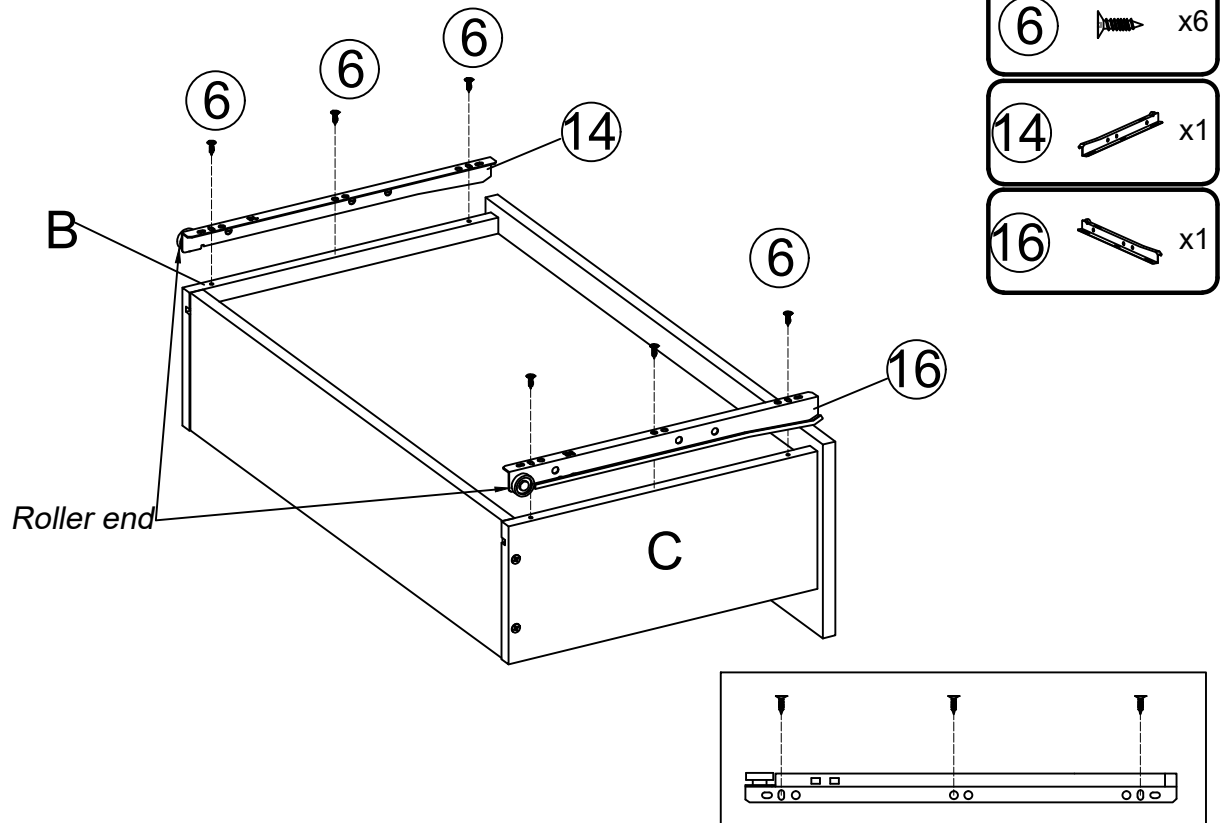

STEP 4

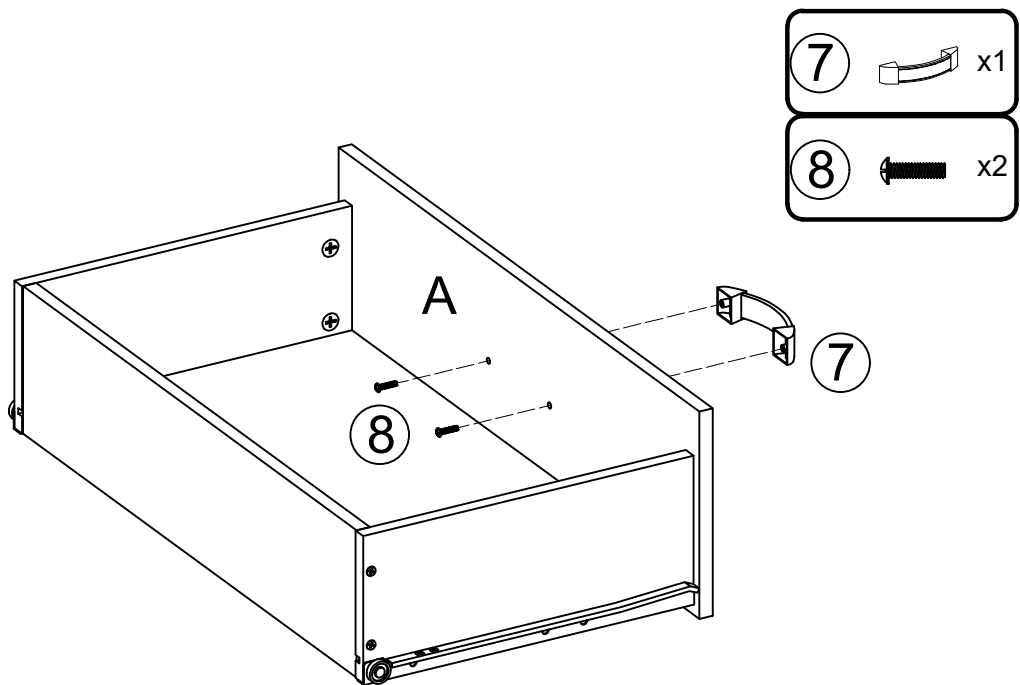

NOTICE:
The installation for all the two drawers is base on the four steps above.

STEP 5

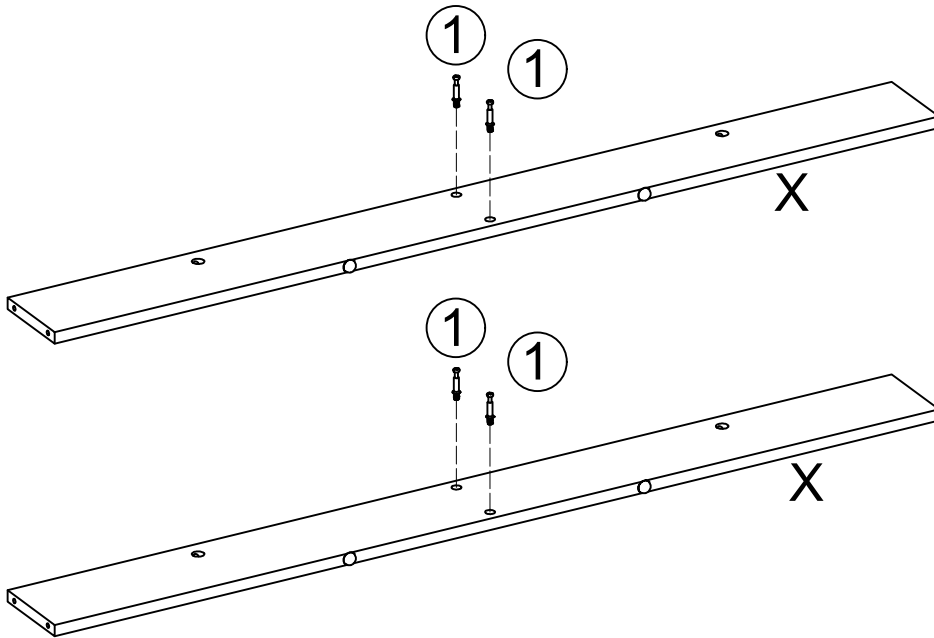
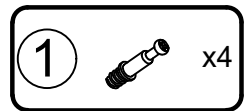

STEP 6

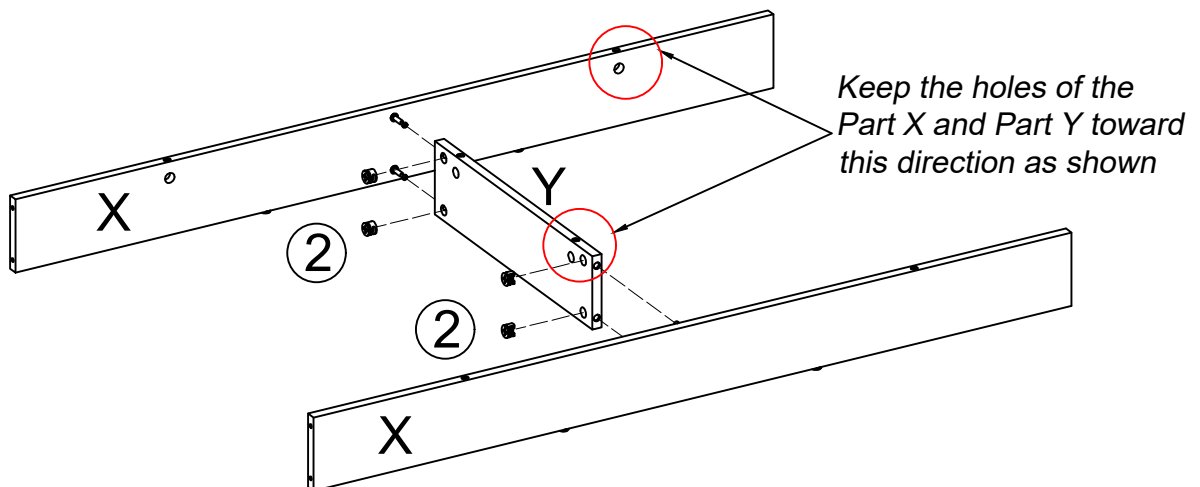
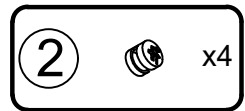

STEP 7

1  x6

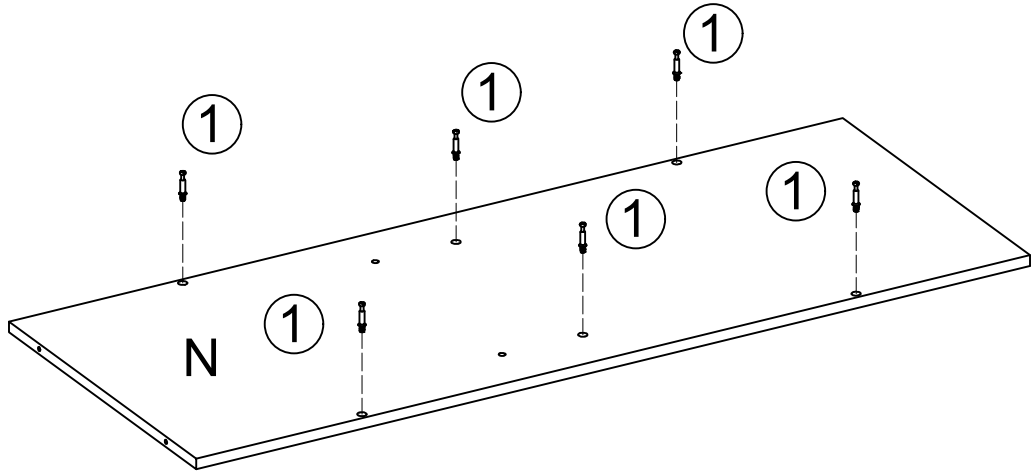

STEP 8

2  x6

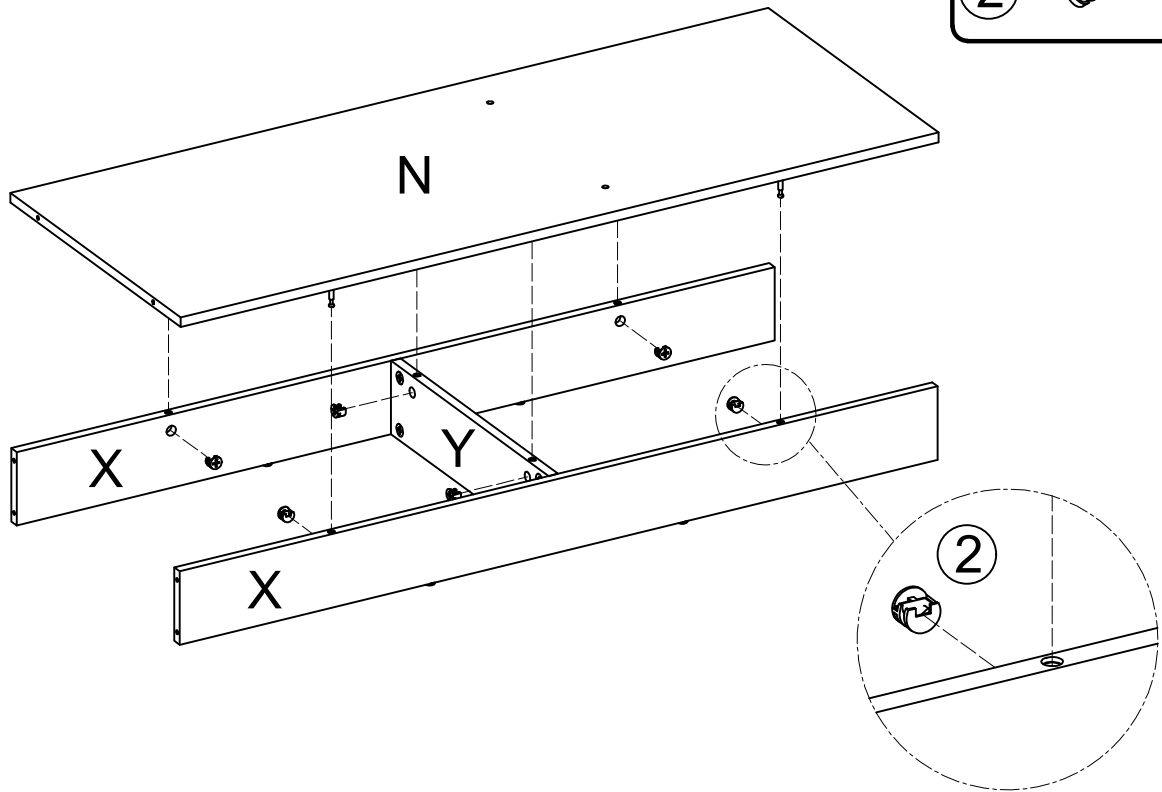

STEP 9

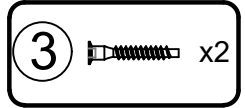

Keep the holes of the Part T toward this direction as shown

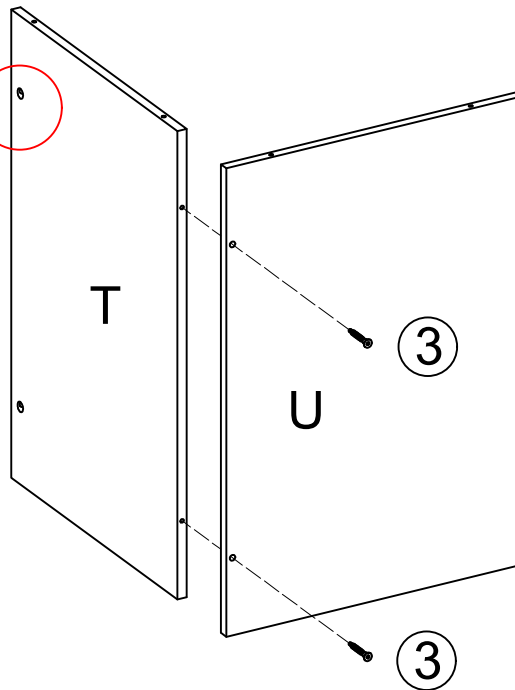

STEP 10

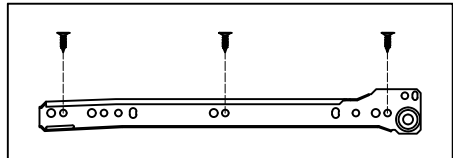
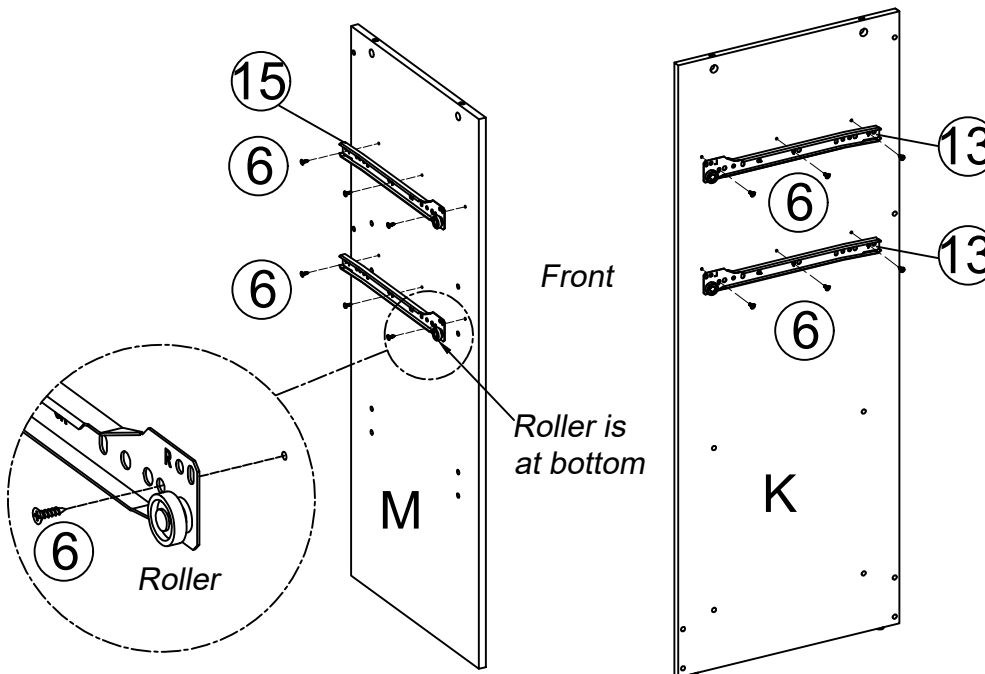
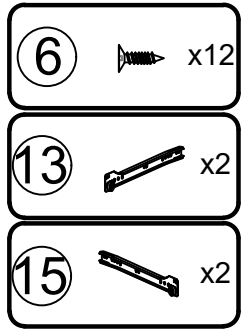

STEP 11

③  x4

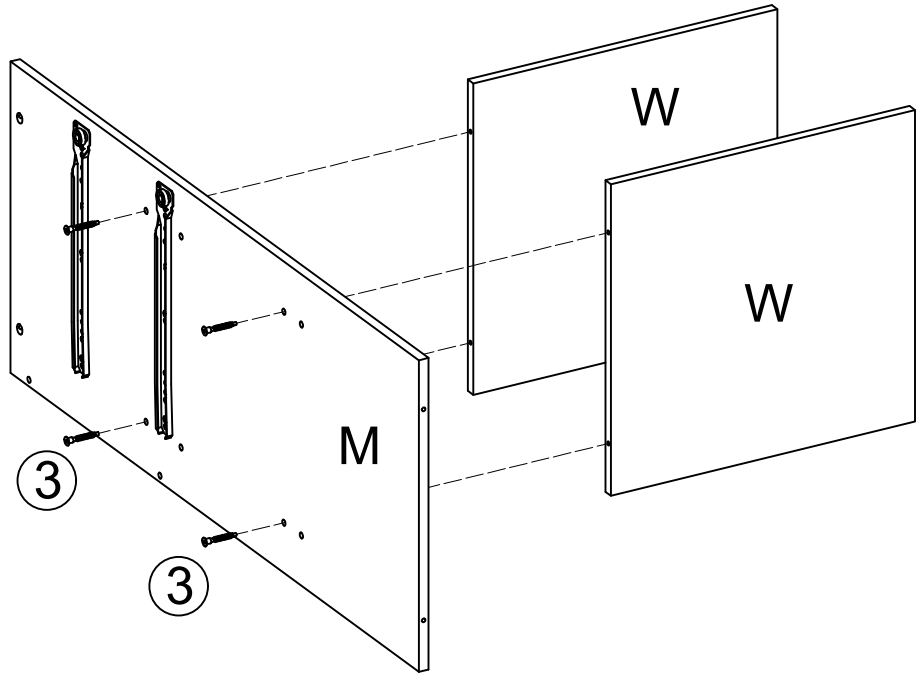

STEP 12

③  x6

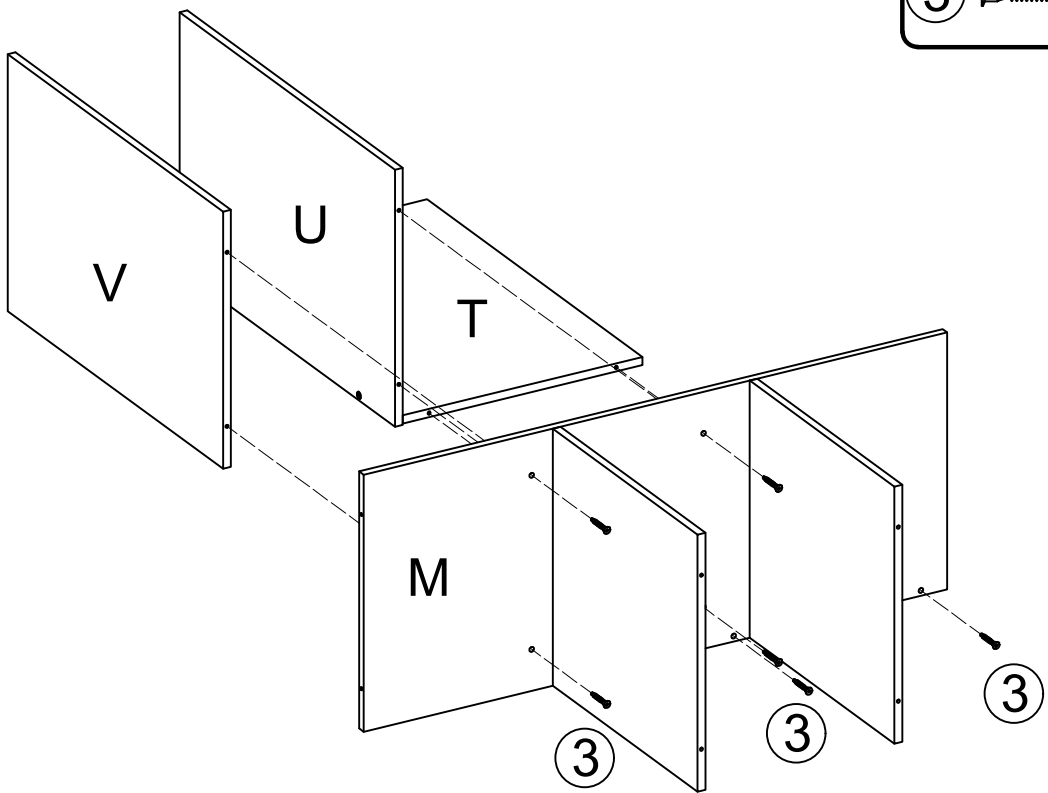

STEP 13

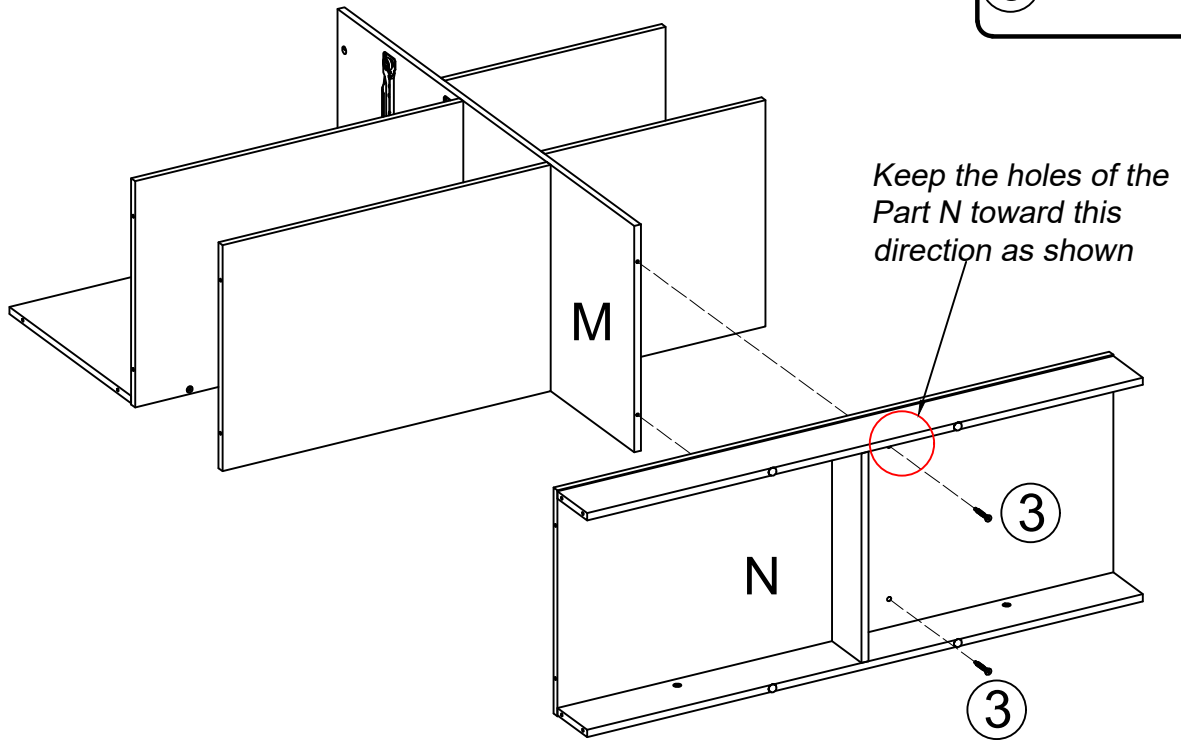
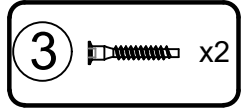

STEP 14

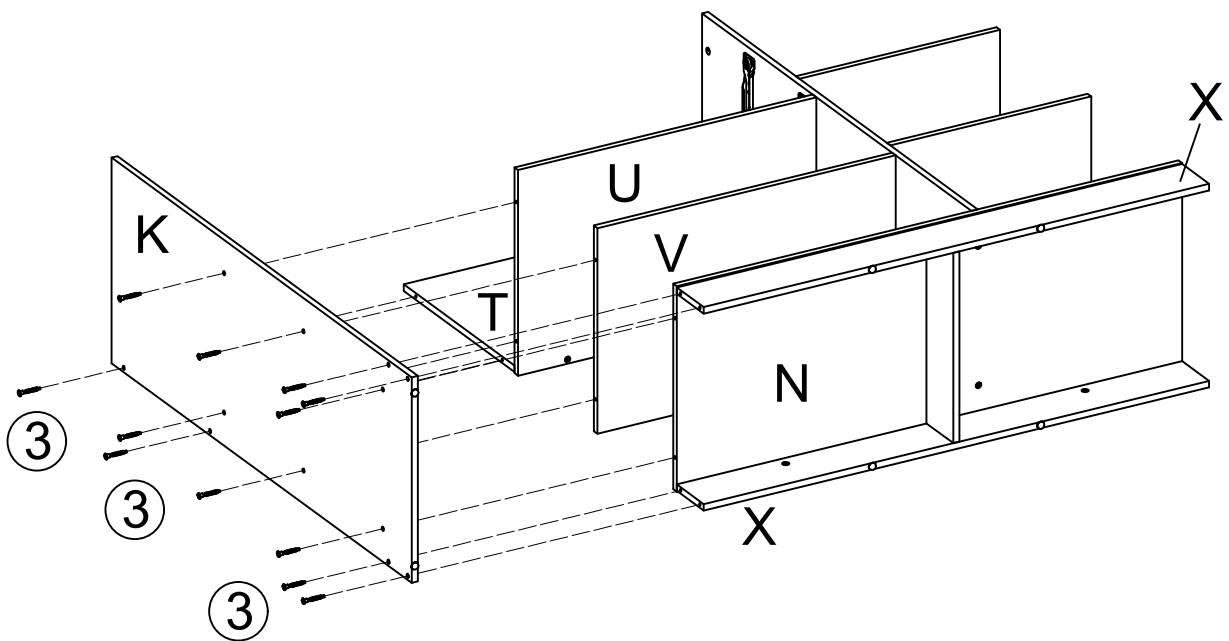
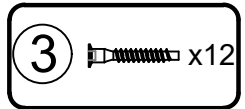

STEP 15

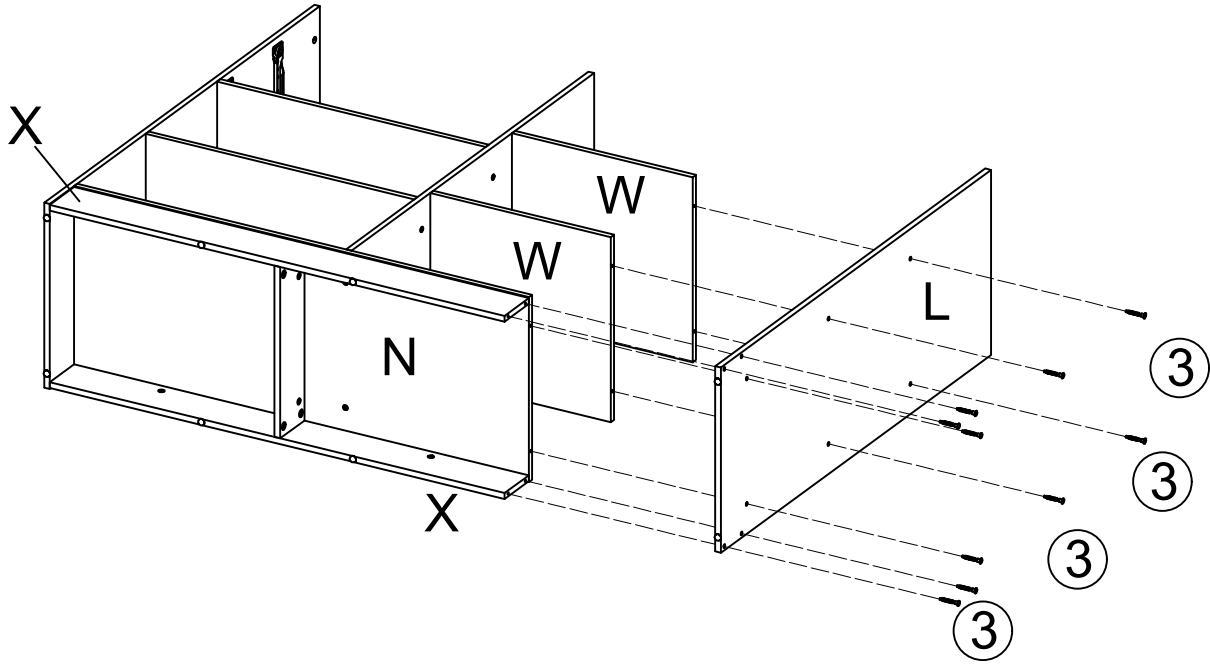
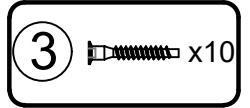

STEP 16

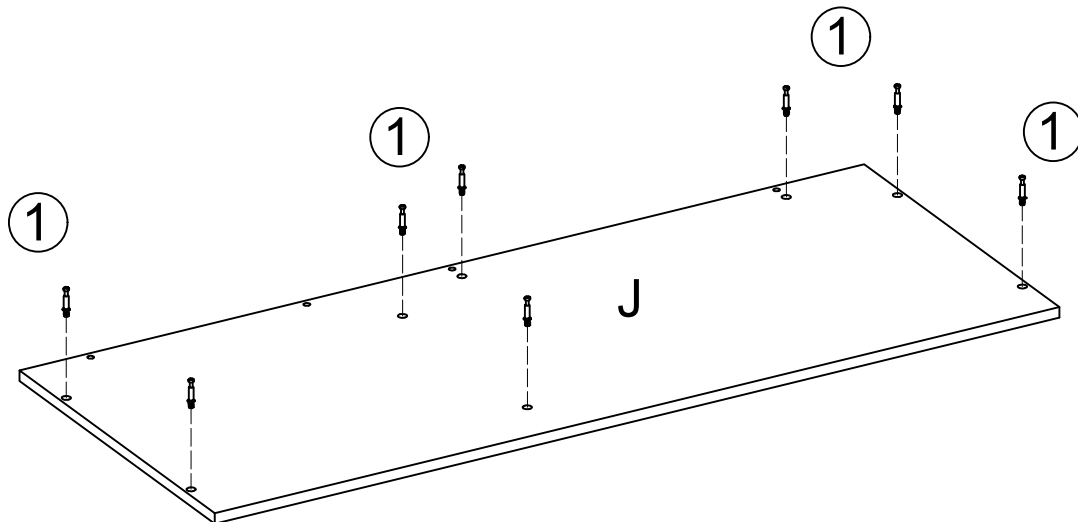
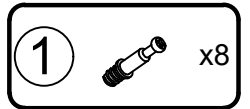

STEP 17

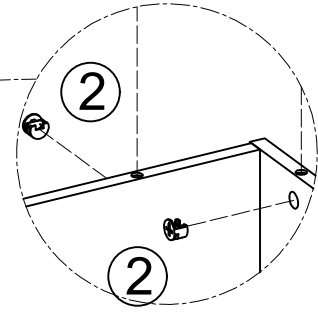
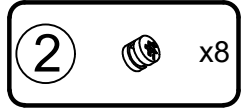
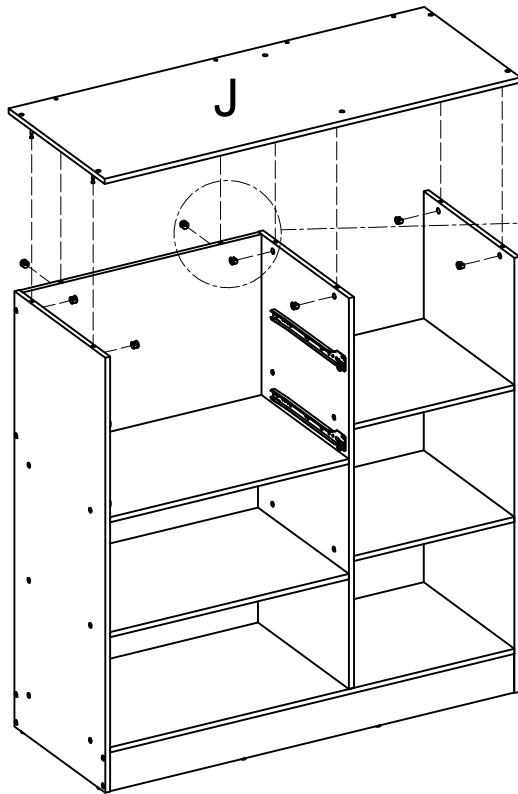

STEP 18

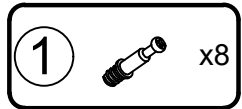
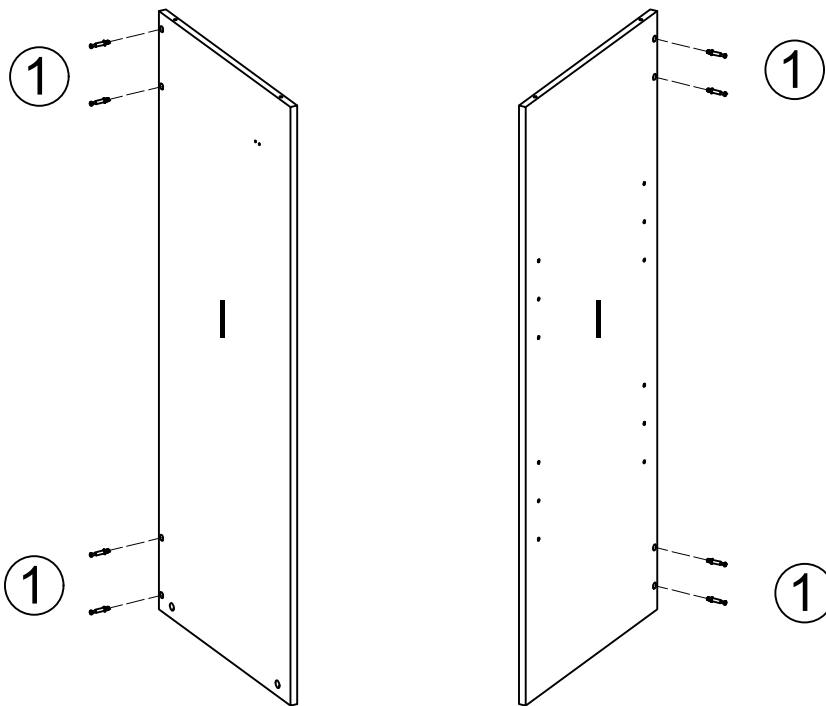

STEP 19

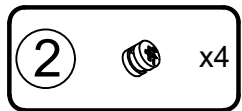

Keep the holes of the Part P and Part R toward this direction as shown

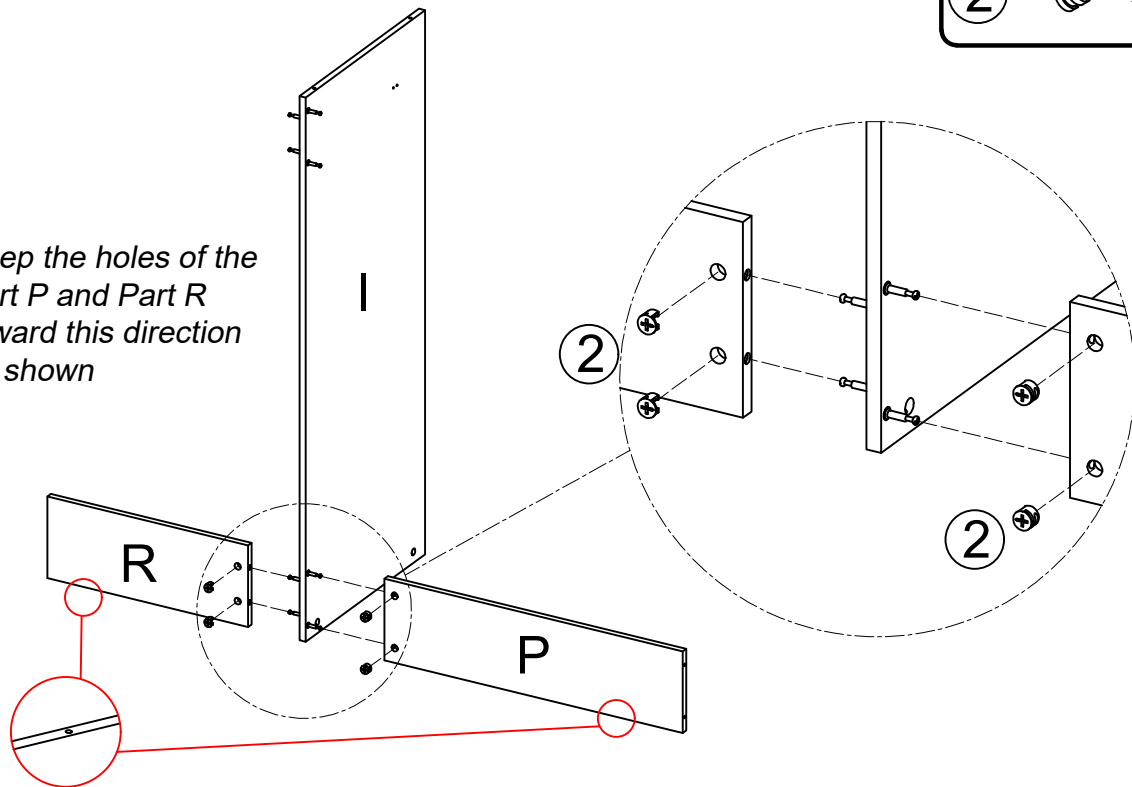

STEP 20

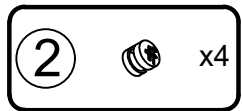

Keep the holes of the Part O and Part Q toward this direction as shown

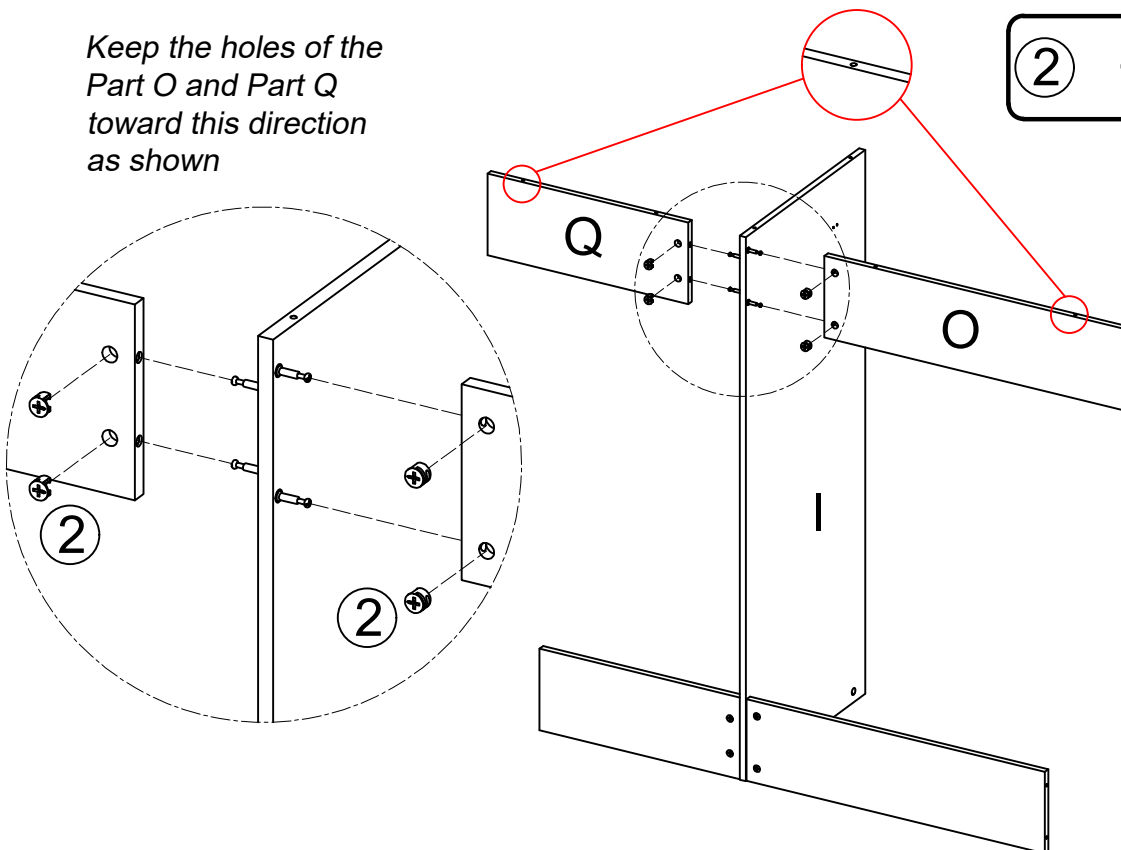

STEP 21

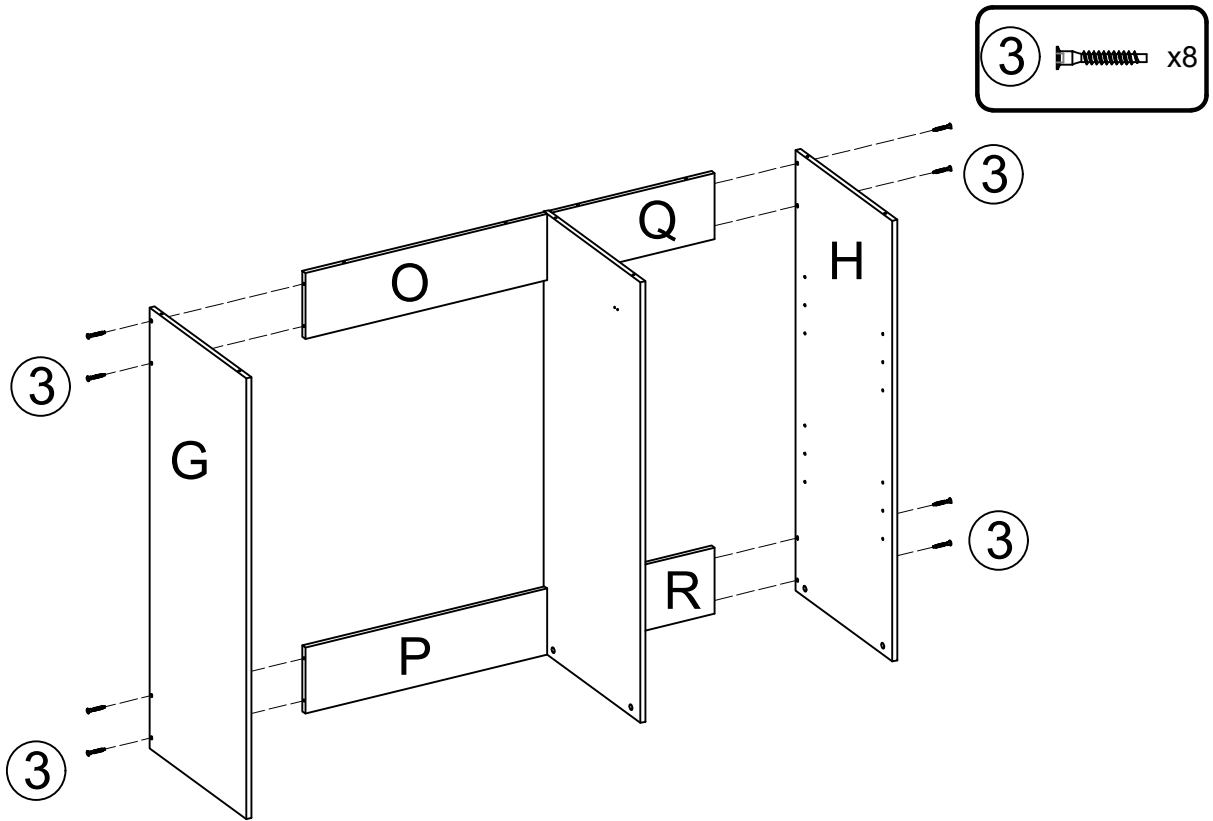

STEP 22

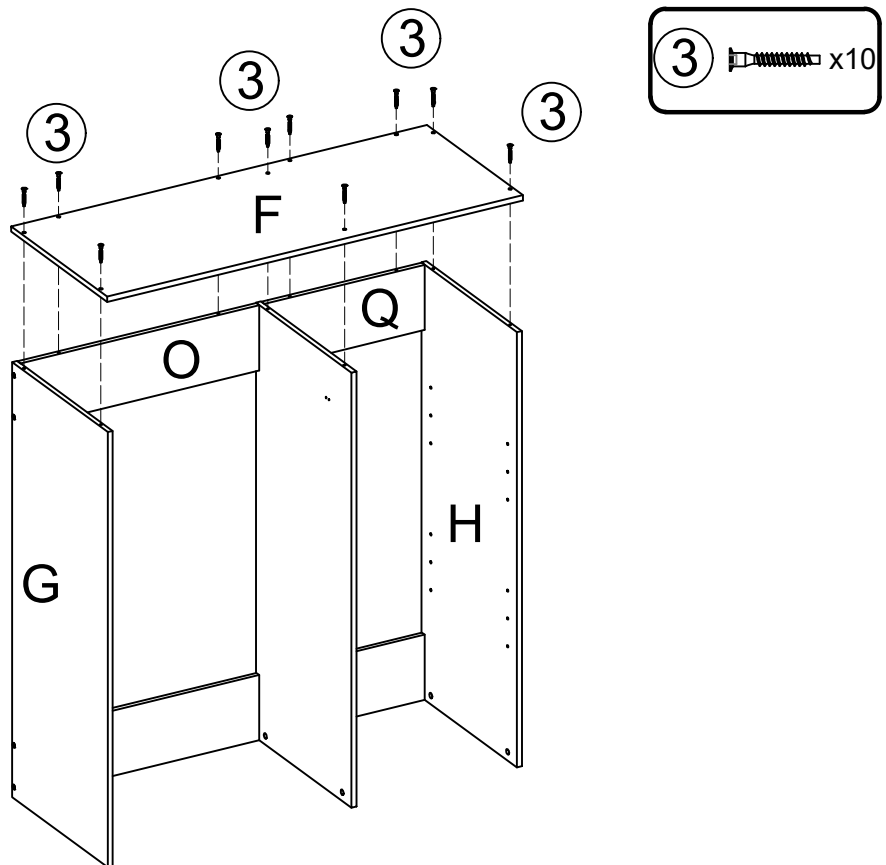

STEP 23

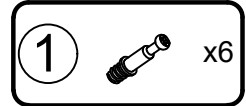
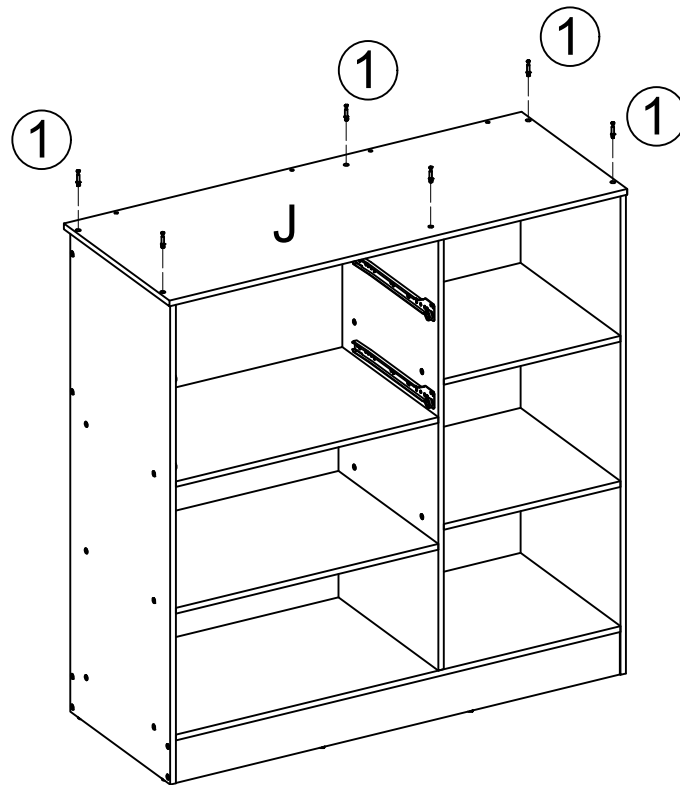

STEP 24

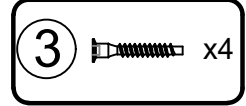
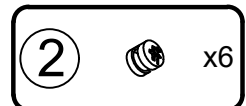
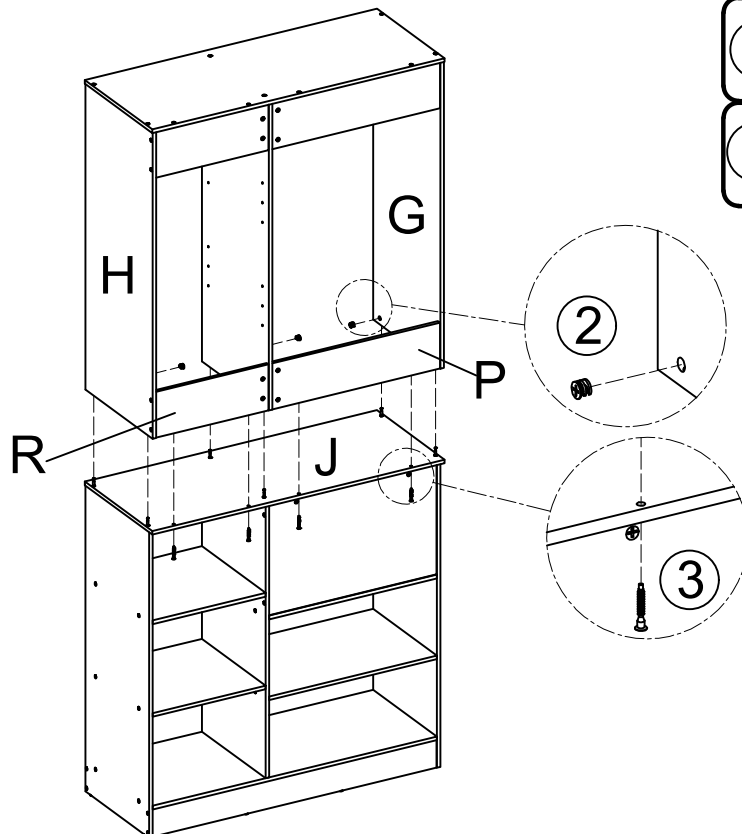

STEP 25

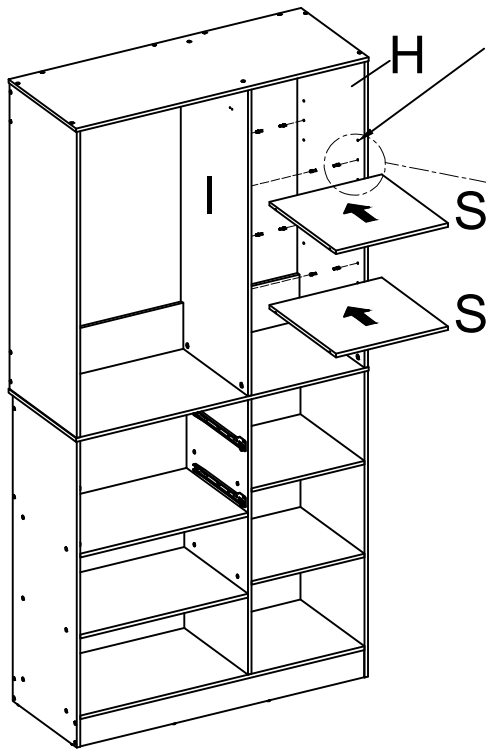

There are 3 heights for the shelf to be adjusted as you need.

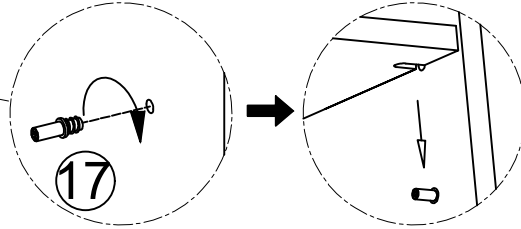
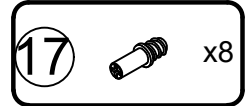

STEP 26

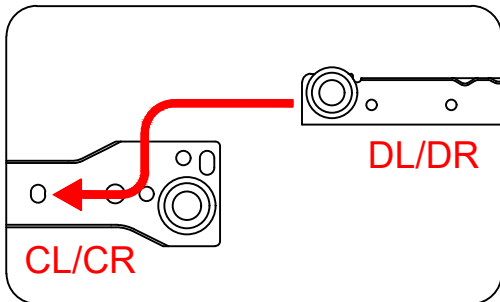

Please put the wheels align with the slots as the instruction shows, then slide into them

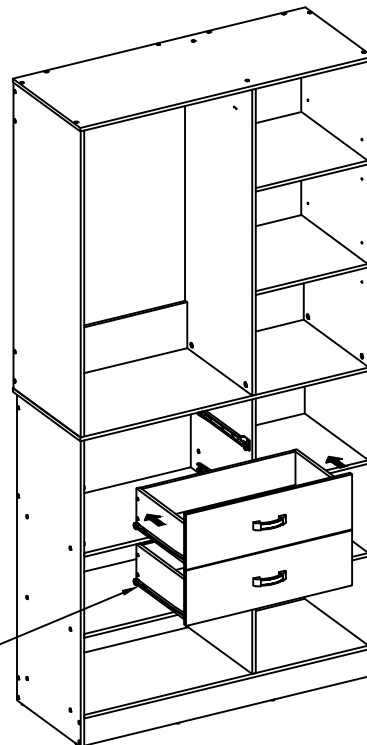

STEP 27

Pole Installation

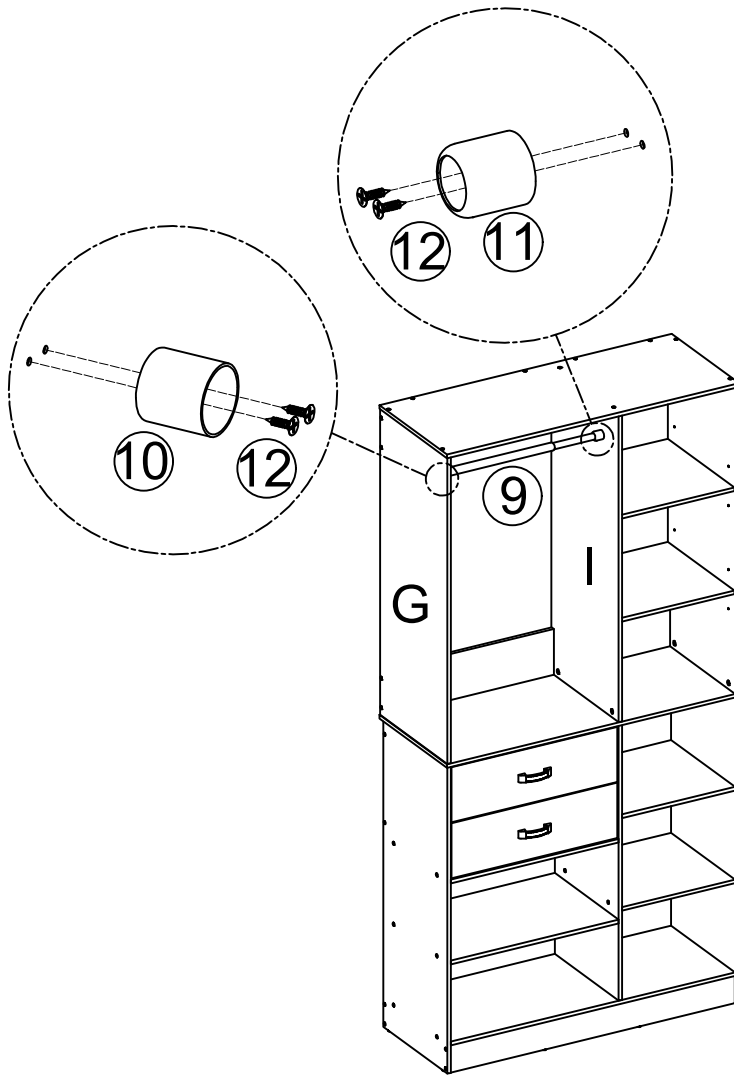

- ⑨ ————— x1
- ⑩ ———— x1
- ⑪ ———— x1
- ⑫ ———— x4

Note: Twist the expandable pole clockwise to tighten. anticlockwise to loosen.

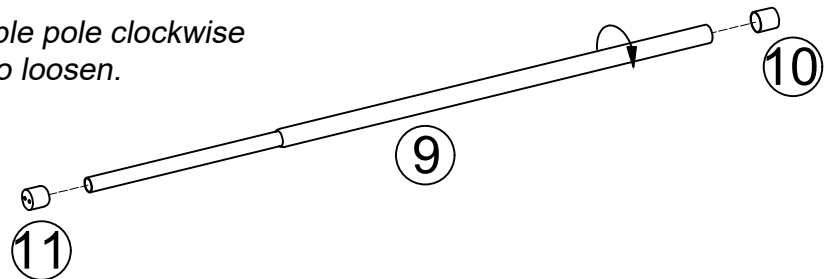

STEP 28

TIPPING RESTRAINT HARDWARE

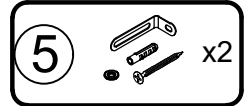

Note: We have included two Tipping Restraint Hardware set for this Unit. When properly installed, this restraint can provide protection against the unexpected tipping of the Unit due to small tremors, bumps or climbing. We strongly recommend mounting this hardware to a wall stud and your Unit.

Note: You must install the Tipping Restraint Hardware with the unit in use to prevent any accidents or damage to the unit.

