

INSTRUCTION MANUAL ENCLOSED

ATTENTION

**IF YOU HAVE ANY PROBLEMS OR QUESTIONS, EMAIL OR CALL
CUSTOMER SERVICE BEFORE YOU RETURN THIS PRODUCT TO THE
STORE WHERE IT WAS PURCHASED.**

****When emailing Customer Service, please include your **Order Number** and **platform of purchase** in the email subject for quicker assistance.**

INSTRUCTION MANUAL ENCLOSED

RELAX CHAIR

RELAX CHAIR ASSEMBLY INSTRUCTION

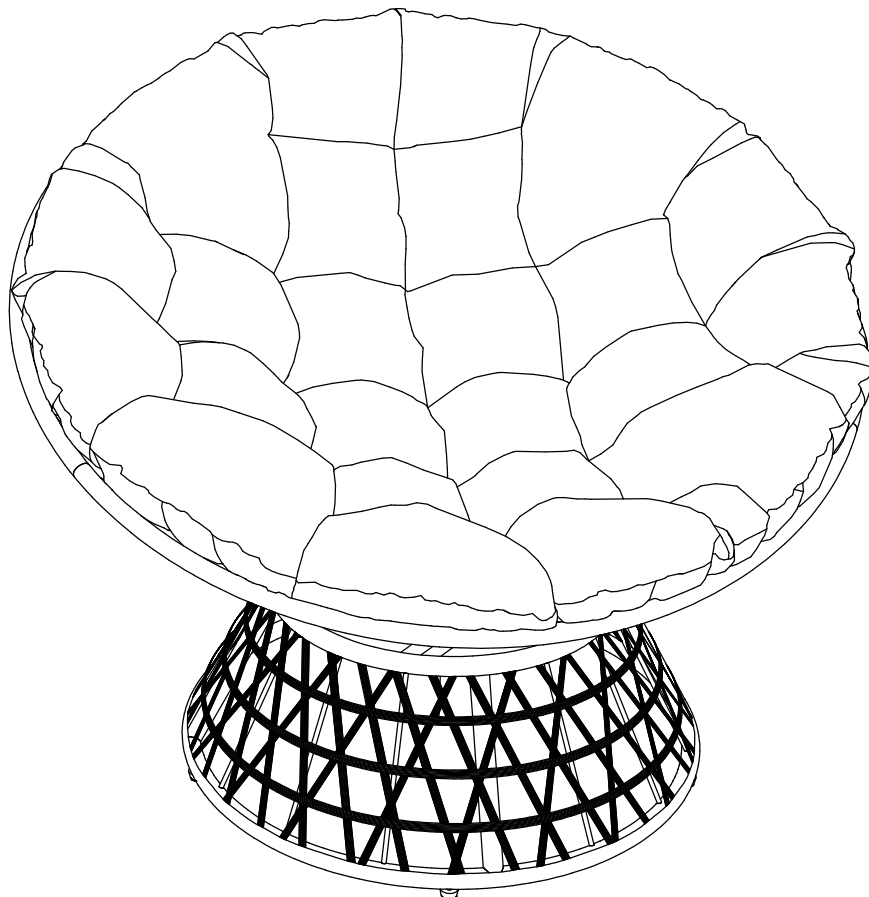

PARTS LIST







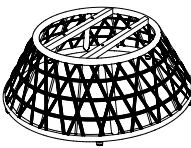
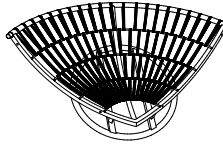
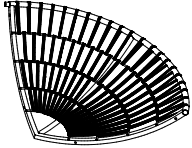
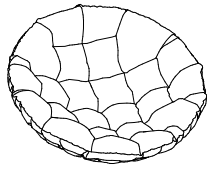

Part	Description	Quantity
------	-------------	----------

PARTS

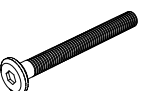
1	Chair base	1
2	Chair seat	1
3	Chair back	2
4	Cushion	1

HARDWARE

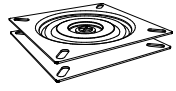
A	Bolt M6x20 mm	8
B	Bolt M6x55 mm	6
C	Washer Ø6x14x1 mm	12
D	Washer Ø6x18x1 mm	8
E	Nut 6	6
F	Turntable 190x190x25 mm	1
G	Allen key 4	2
H	Wrench 10	1

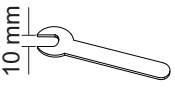
<p>1</p>  <p>x1</p>	<p>2</p>  <p>x1</p>	<p>3</p>  <p>x2</p>	<p>4</p>  <p>x1</p>
<p>A</p>  <p>M6x20 mm</p> <p>x8</p>	<p>B</p>  <p>M6x55 mm</p> <p>x6</p>	<p>C</p>  <p>Ø6x14x1 mm</p> <p>x12</p>	<p>D</p>  <p>Ø6x18x3 mm</p> <p>x8</p>
<p>E</p>  <p>M6 mm</p> <p>x6</p>	<p>F</p>  <p>190x190x25 mm</p> <p>x1</p>	<p>G</p>  <p>4x98 mm</p> <p>x2</p>	<p>H</p>  <p>10 mm</p> <p>90x25x2 mm</p> <p>x1</p>

PLEASE READ AND FOLLOW ALL SAFETY TIPS

GETTING STARTED

1. Before assembly, CAREFULLY use scissors or utility knife to cut and unwrap all parts. Make sure you do not discard the hardware.
2. Make sure that you have all the parts listed. If you are missing any parts, please email us. Please identify the parts you need and model number. Make sure to include your name and address.
3. Please include your **Order Number** and **platform of purchase** in the email subject, and one of our customer service representative will get back to you.

Warm Tips:

1. The plastic covers on some metal parts are just for product protection. Please remove it before assembly.
2. Please follow the sequence of AI during assembly.
3. Do not tighten the screws until all of them are in right positions.

1. Attach 2 chairs back (3) to the chair seat (2) as shown in the picture.

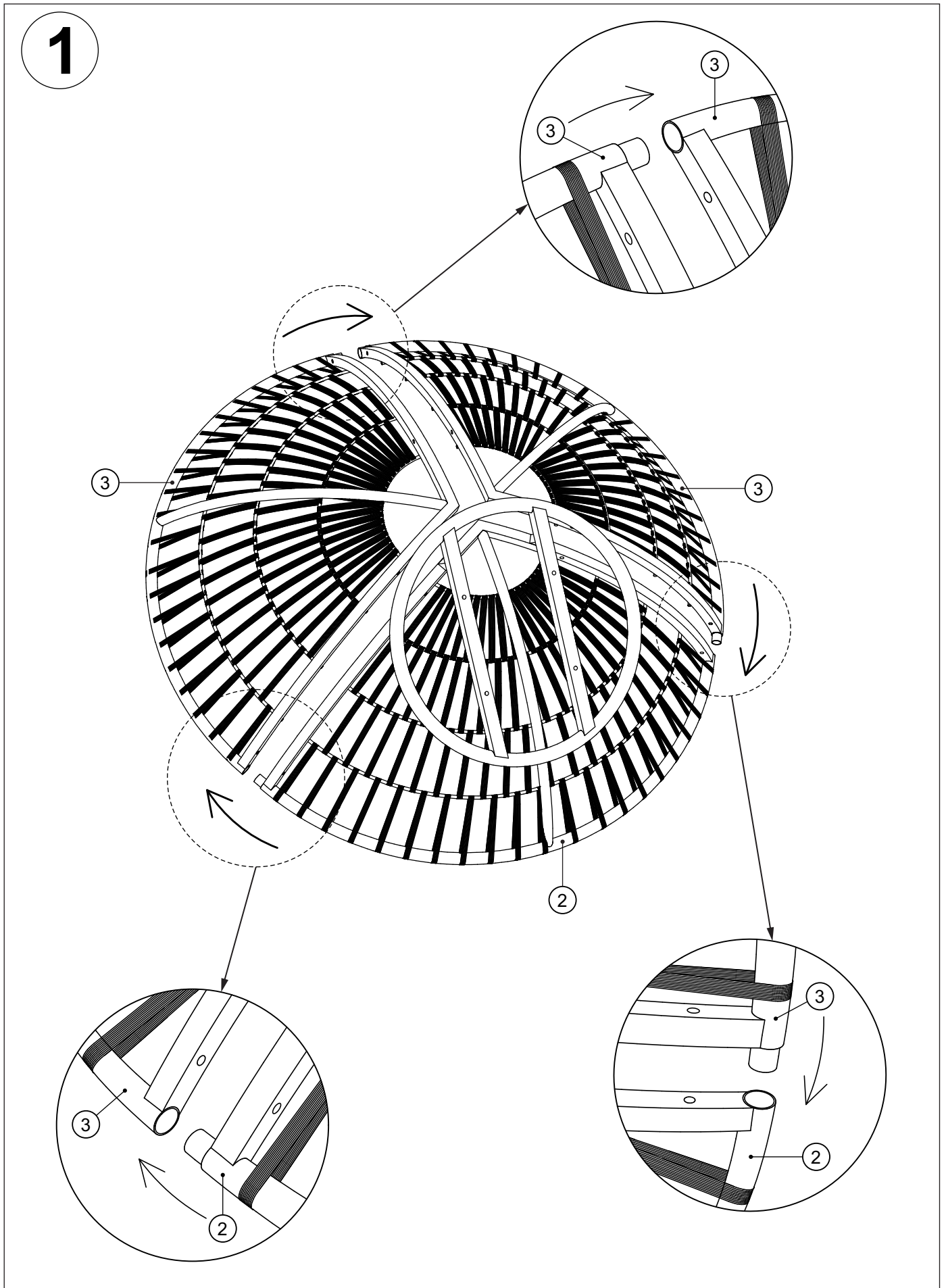

2. Use Allen Key (G) to tighten Bolts (B), nuts (E), washers (C), and wrench tool (H).
Note: only tighten 80%. Then tighten 100% of them all using the allen key and wrench tool (Photo 2).

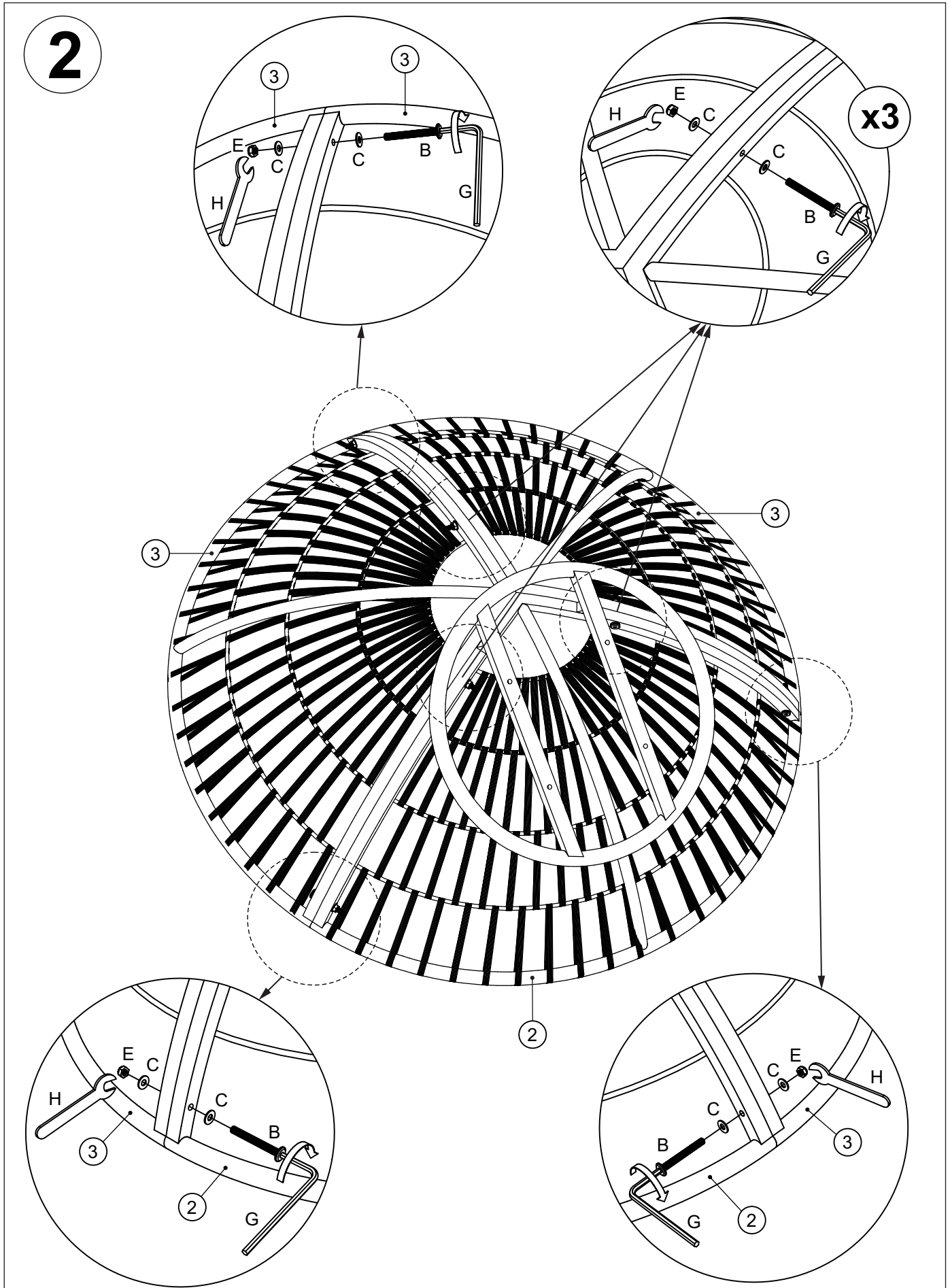

3. Locate the turntable hardware (F) onto the chair base (1) by the pre-drilled threads. Use Allen Key (G) to tighten Bolts (A) and Washers (D). Note: tighten all bolts 100% (Photo 3).

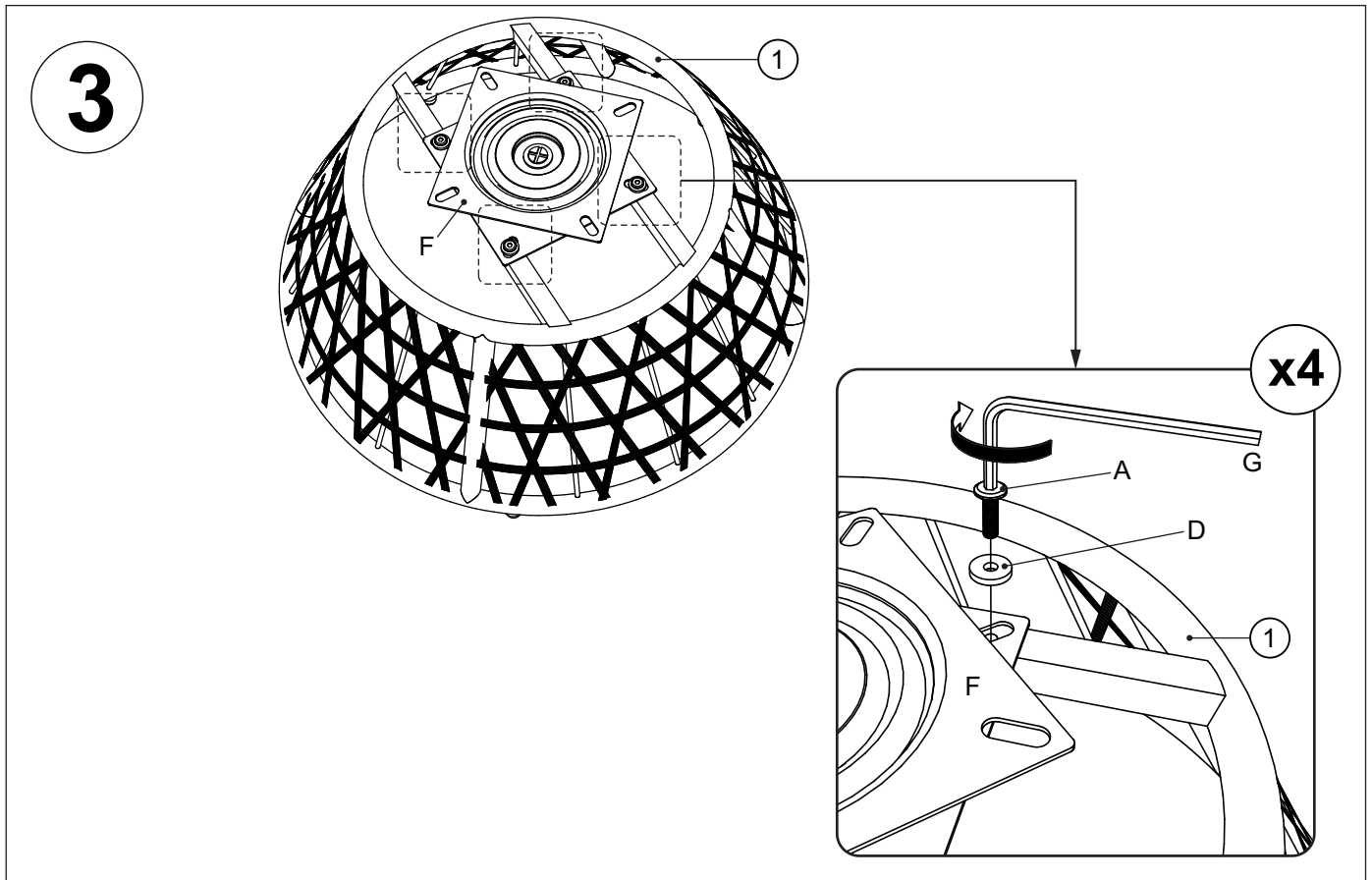

4. Locate the assembly installed in step (3) into the assembly installed in step (2) (Photo 4).

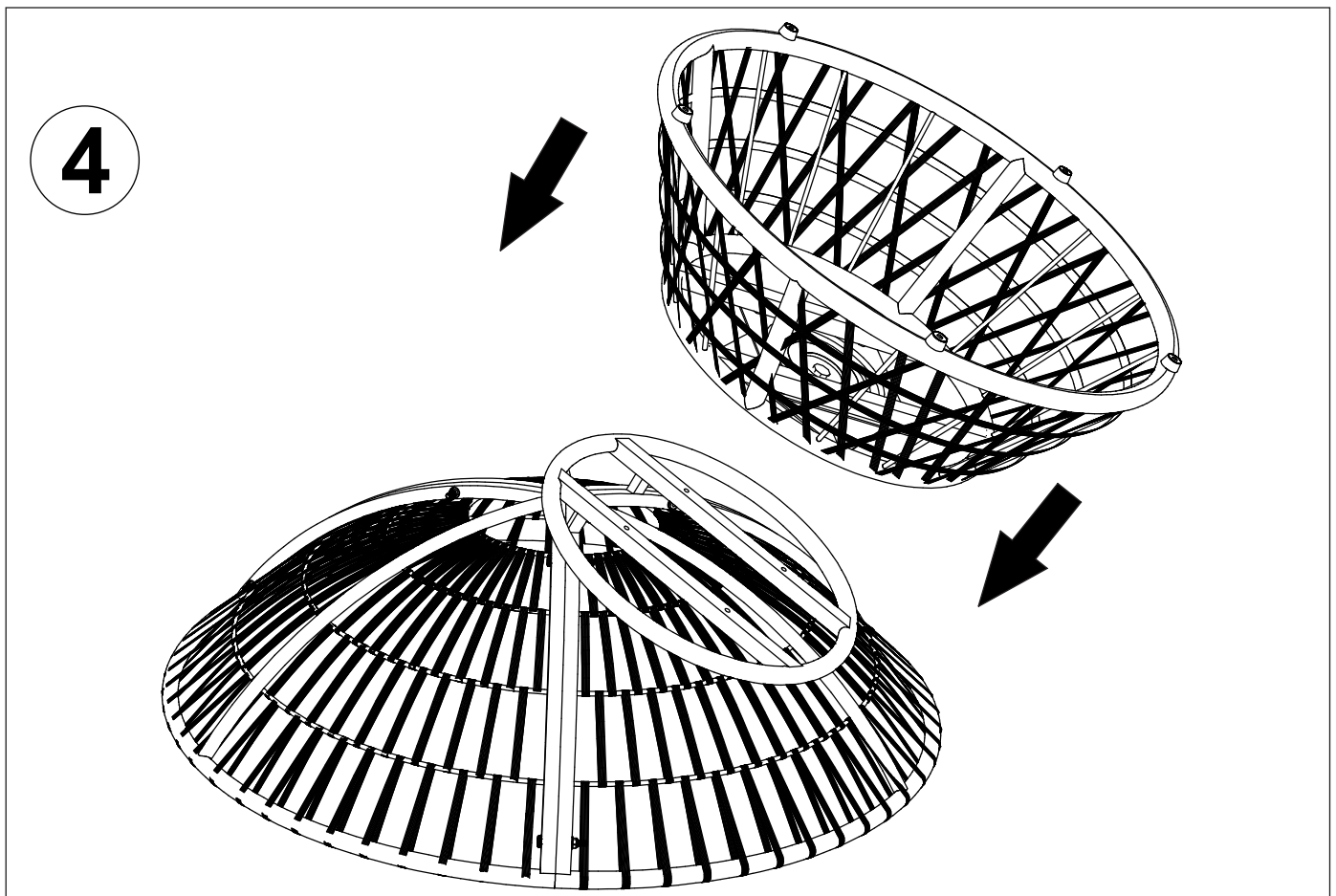

5. Use Allen Key (G) to tighten Bolts (A) and Washers (D).
Note: tighten all bolts 100% (Photo 5).

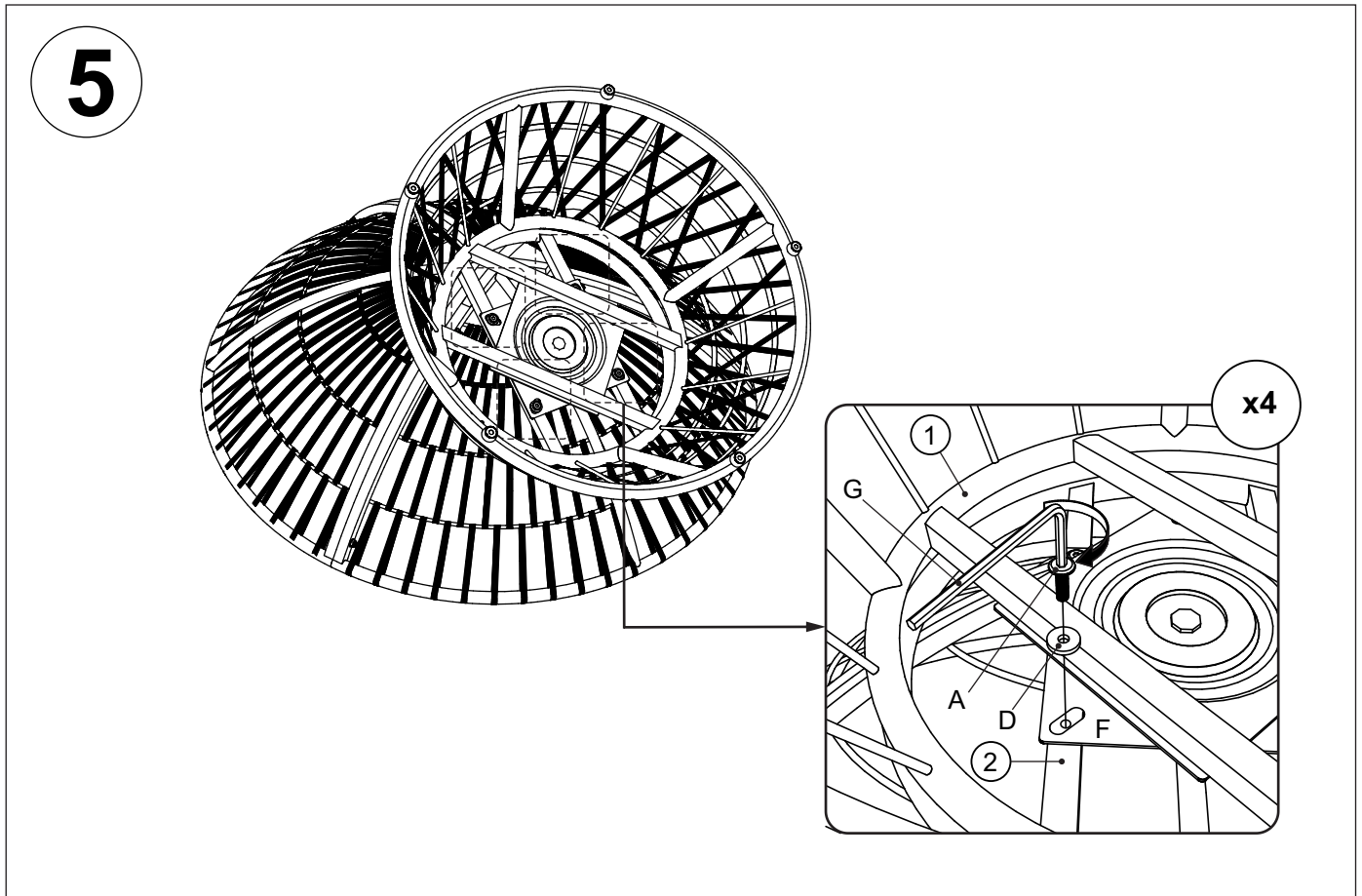

6. Place cushion (4) on the chair. Complete.(Photo 6).

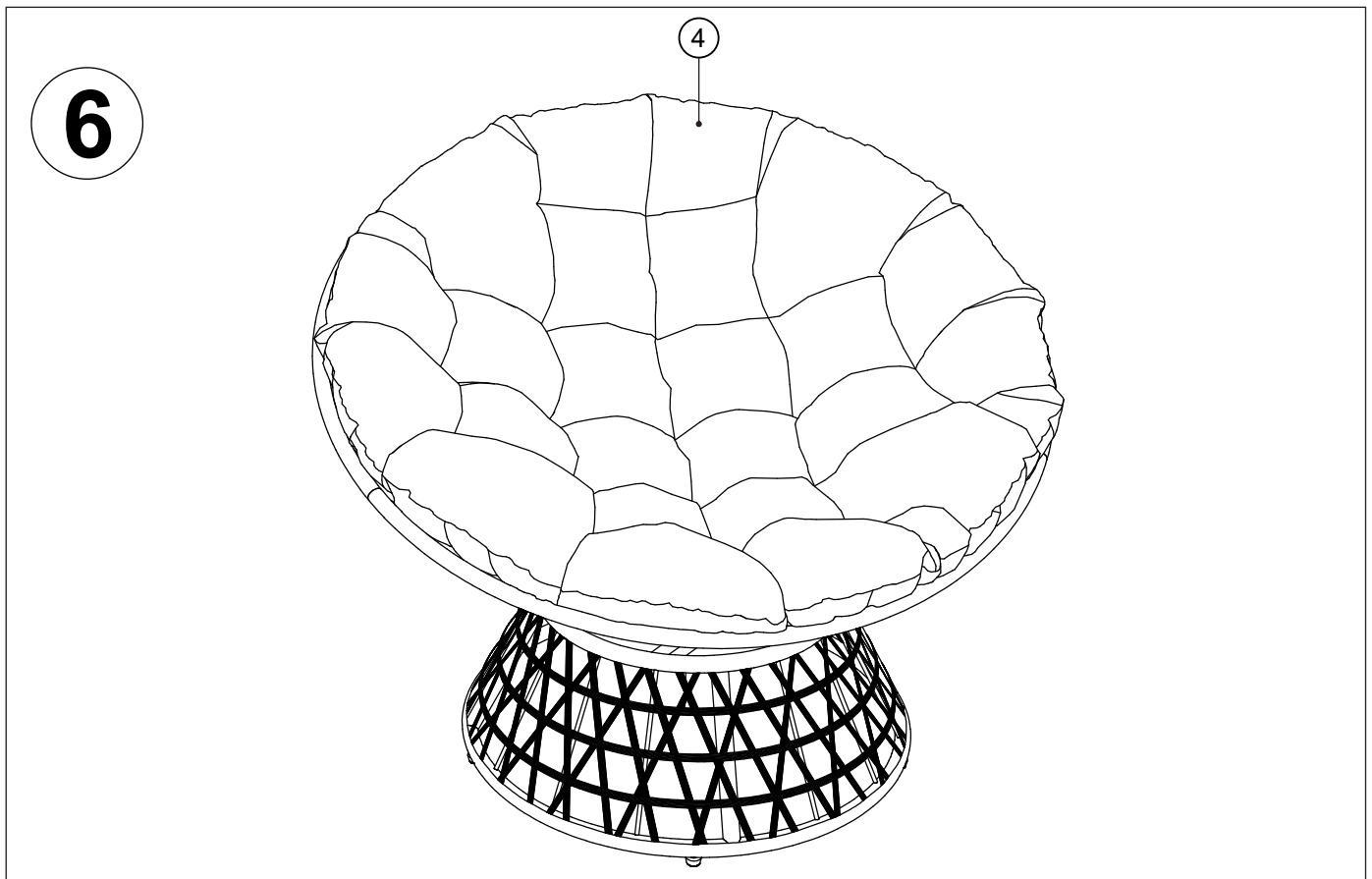

Till now you have finished the whole assembly and enjoy your furniture!