

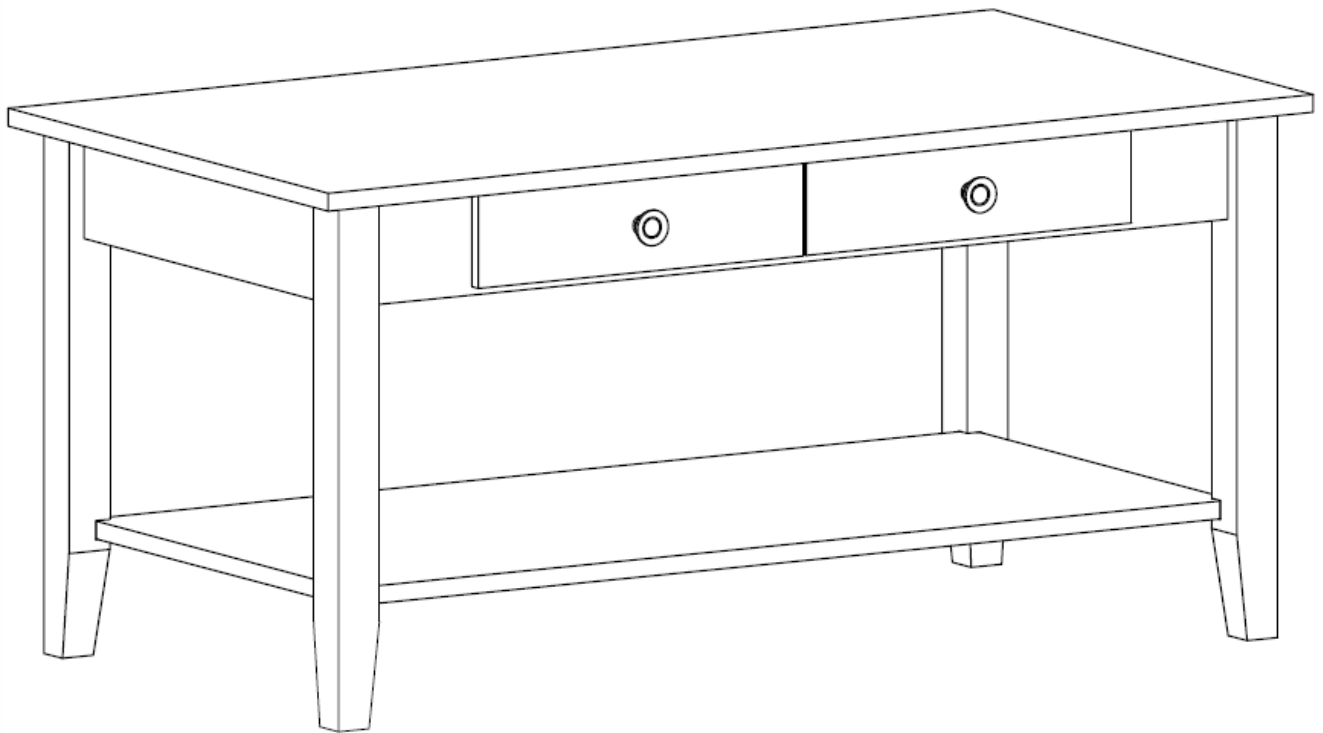









## ASSEMBLY INSTRUCTIONS

Place all parts on a clean and soft surface such as a rug or carpet to avoid scratching during assembly. Please follow all assembly instructions step by step. It is best to use a screwdriver as opposed to a drill during assembly to avoid over tightening or stripping screws/bolts.



### HARDWARE LIST:

| CODE | PICTURE   | DESCRIPTION               | QTY |
|------|---|---------------------------|-----|
| A    |  | 4 X 20MM ROUND HEAD SCREW | 16  |
| B    |  | BOLT FOR KNOB             | 2   |
| C    |  | KNOB                      | 2   |
| D    |  | PLASTIC STOPPER           | 2   |
| E    |  | WRENCH                    | 1   |
| F    |  | 3 X 12MM FLAT HEAD SCREW  | 10  |
| G    |  | METAL BRACKET             | 4   |
| H    |  | BOLT                      | 8   |
| I    |  | WASHER                    | 8   |
| J    |  | 3 X 20MM FLAT HEAD SCREW  | 8   |

### PARTS LIST:

| CODE | DESCRIPTION      | QTY |
|------|------------------|-----|
| 1    | TOP PANEL        | 01  |
| 2    | SLIDE CROSSBAR   | 02  |
| 3    | SIDE SHORT APRON | 02  |
| 4    | BACK LONG APRON  | 01  |
| 5    | FRONT LONG APRON | 01  |
| 6    | LEGS             | 04  |
| 7    | SHELF PANEL      | 01  |
| 8    | DRAWER FRONT     | 01  |
| 9    | DRAWER SIDE      | 02  |
| 10   | DRAWER BACK      | 01  |
| 11   | DRAWER BOTOM     | 01  |

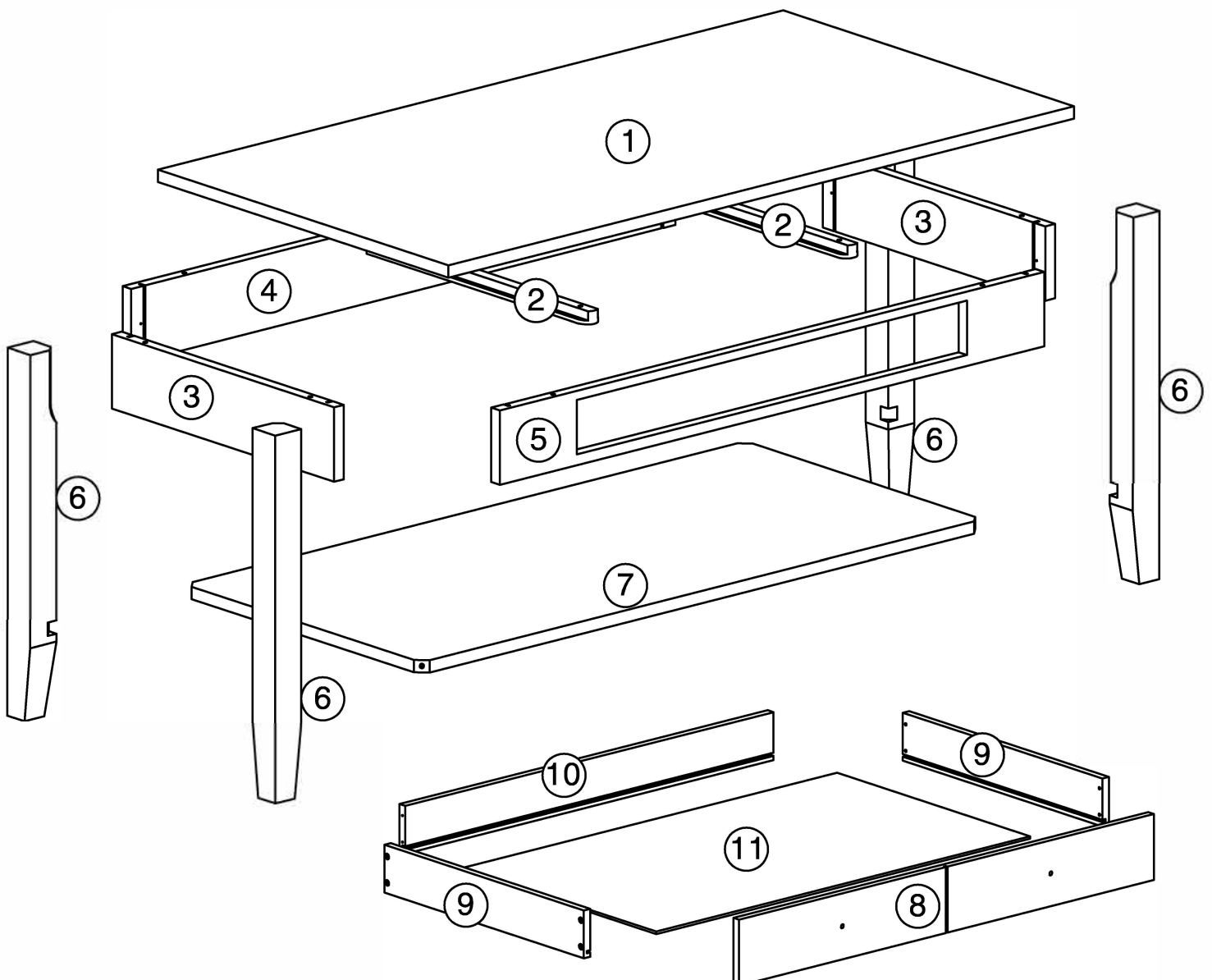

# STEP 1

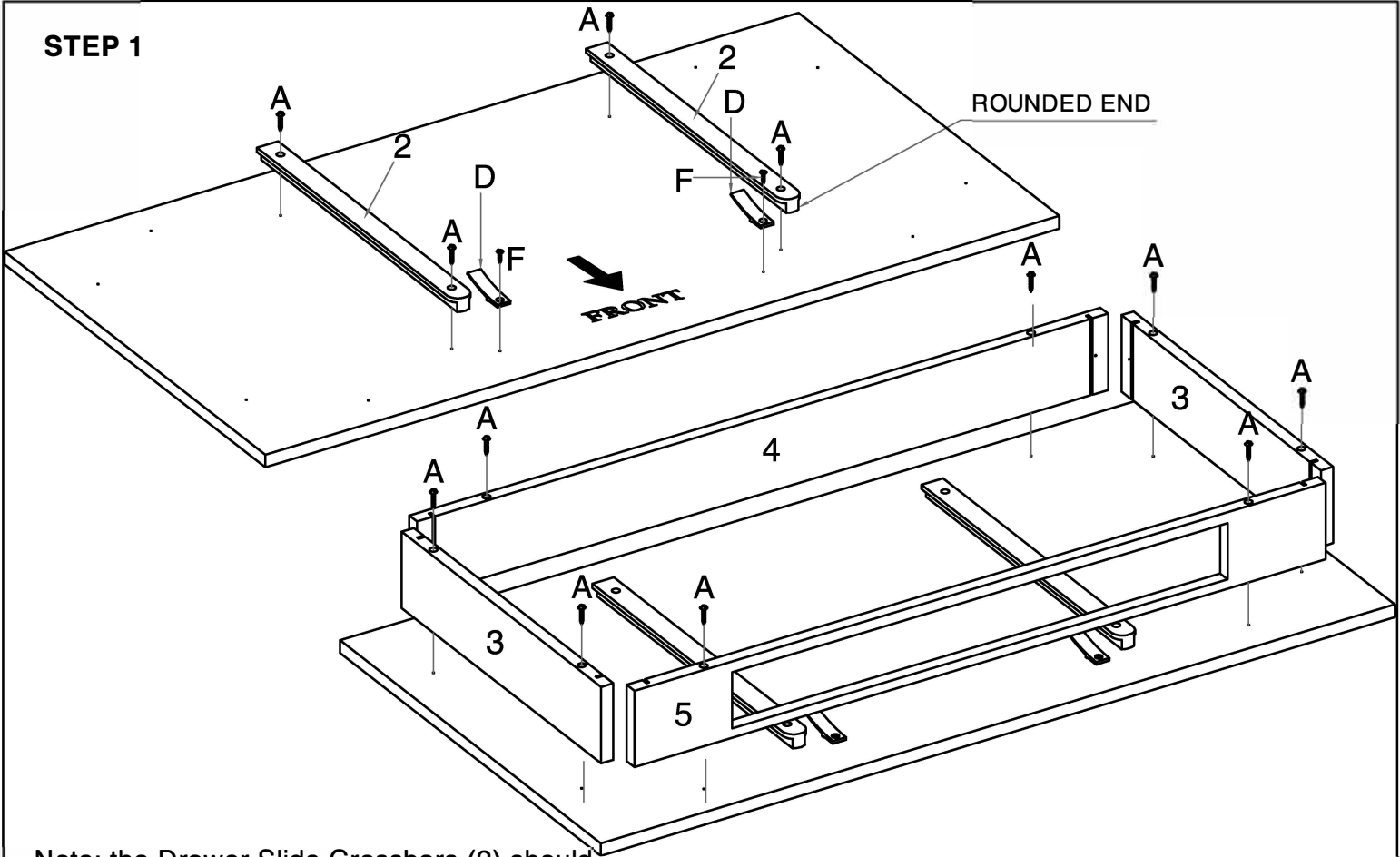

Note: the Drawer Slide Crossbars (2) should be assembled with round end toward the front of the table and with the widest part of its surface away from the table top as shown.

# STEP 2

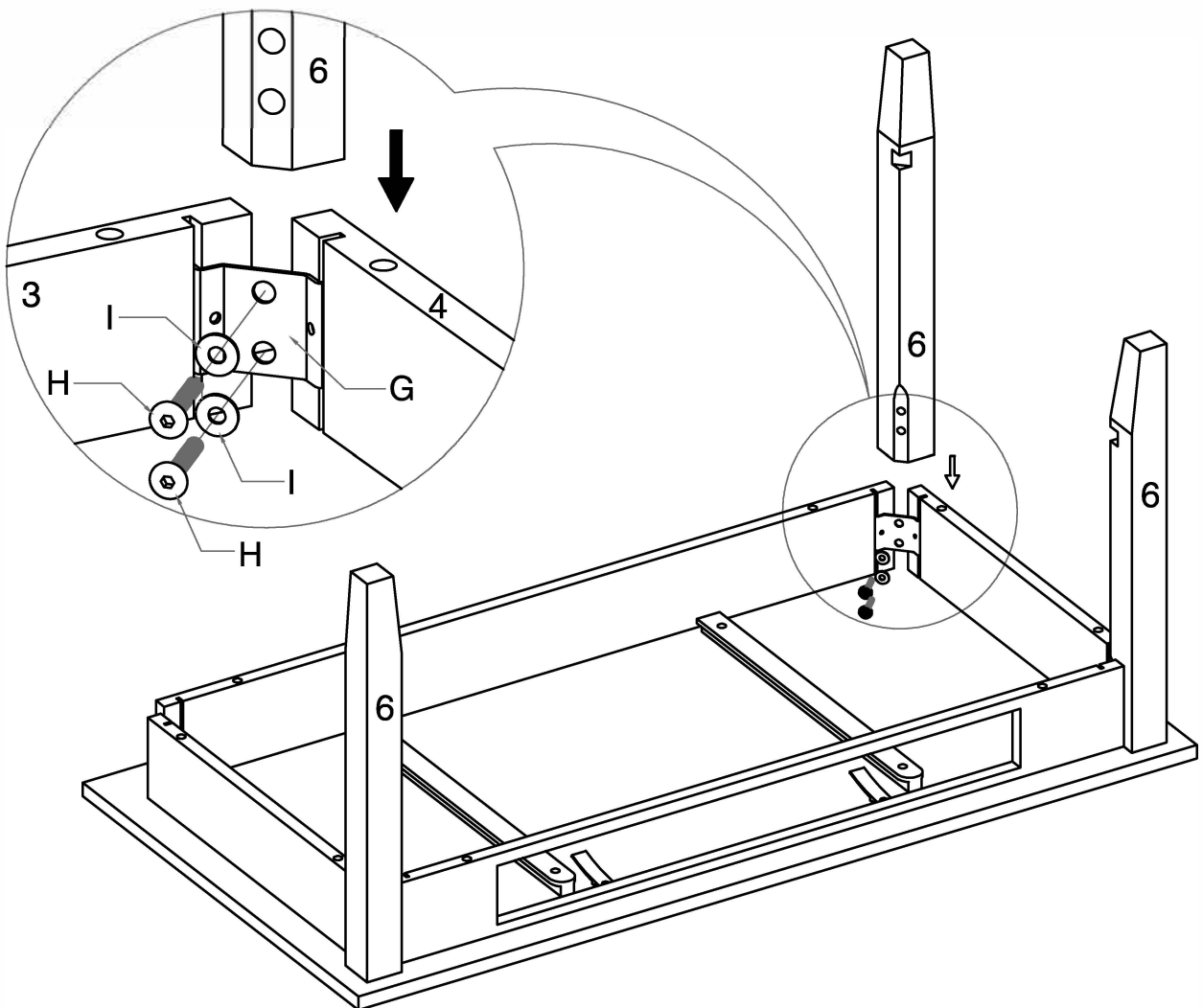

**STEP 3**

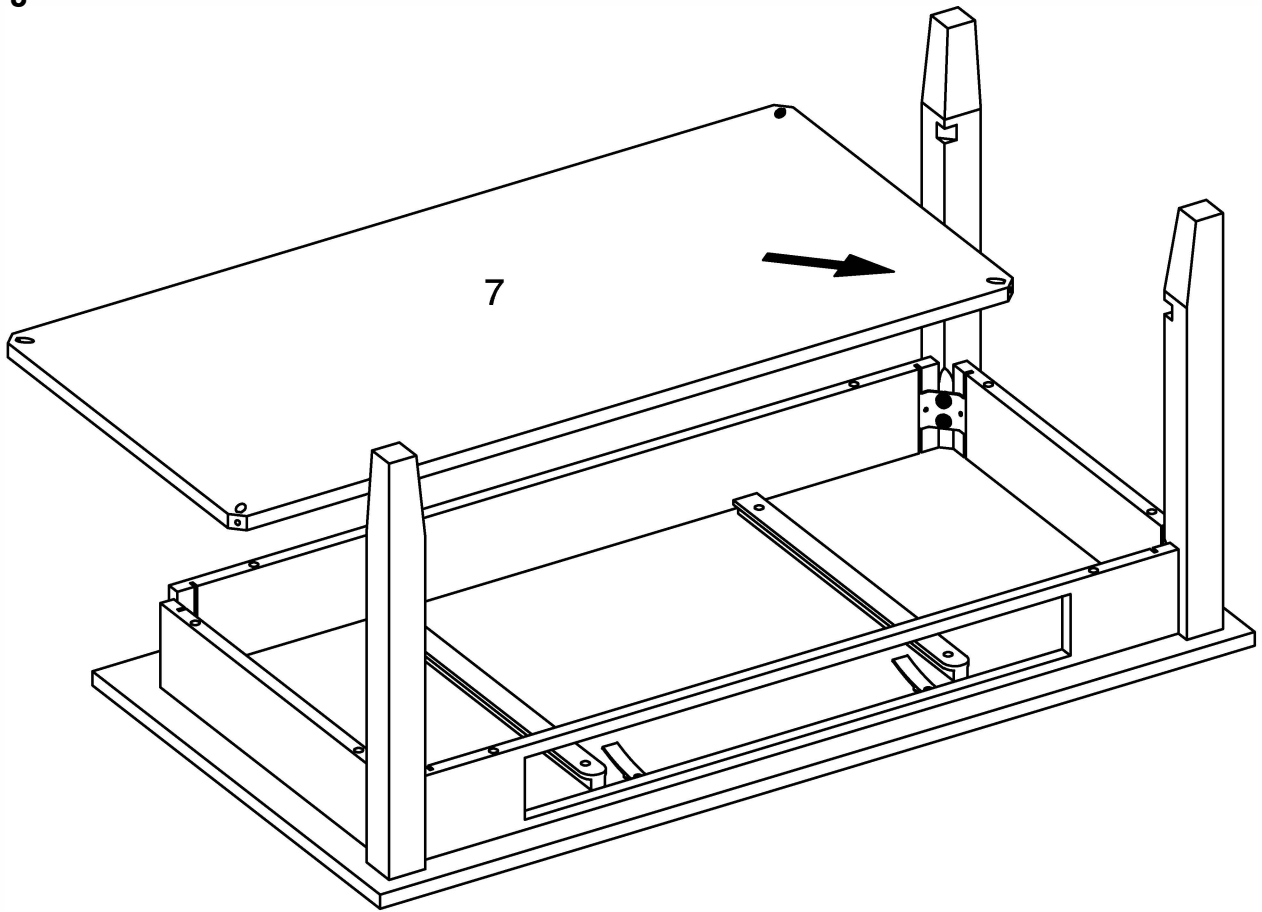

**STEP 4**

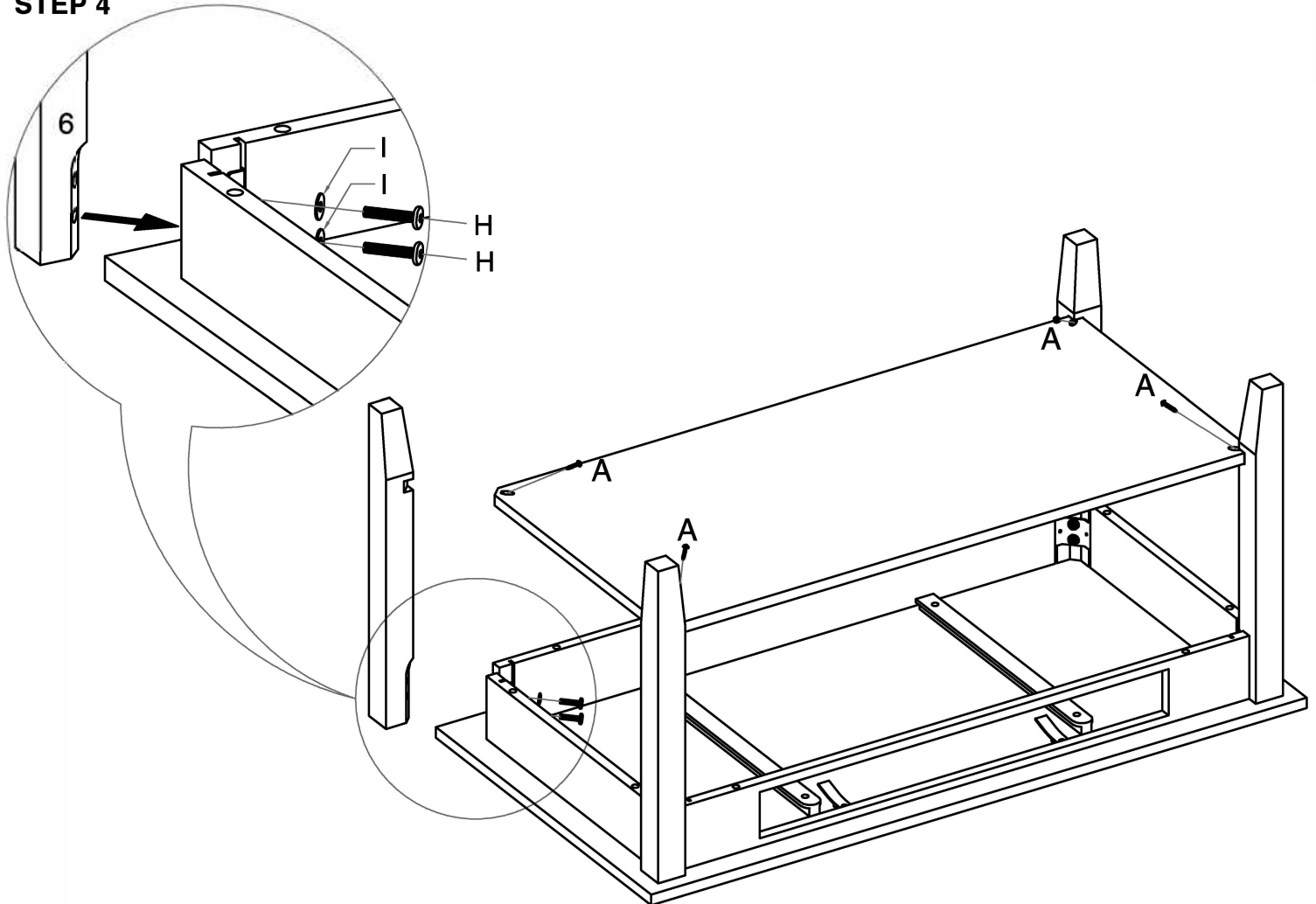

### STEP 5

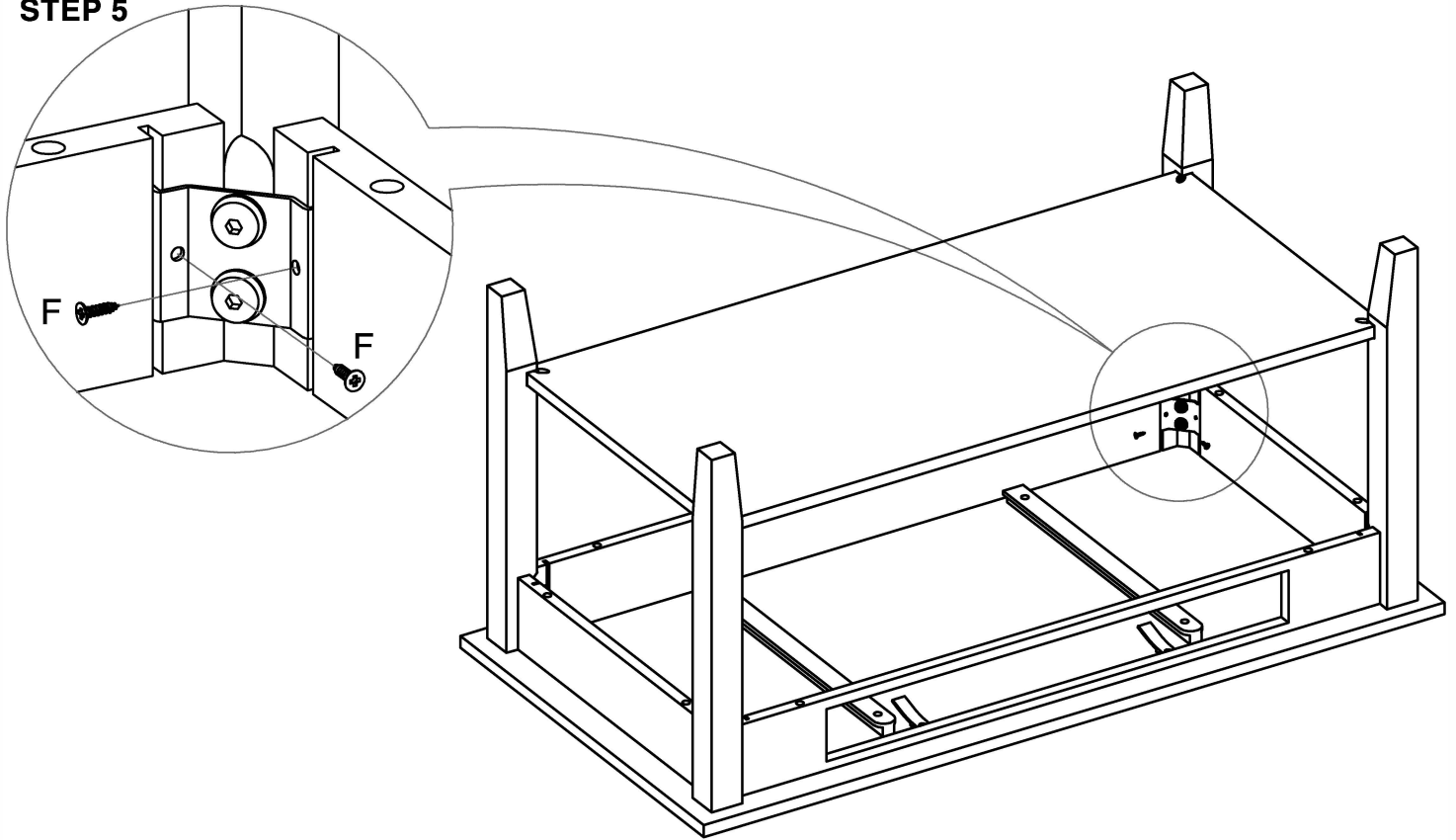

Note: Use a Phillips screwdriver to attach screws F to the metal brackets after tightening bolts (H) with washers (I) to each corner. If you use a drill, be careful not to over tighten or strip the wood.

### STEP 6

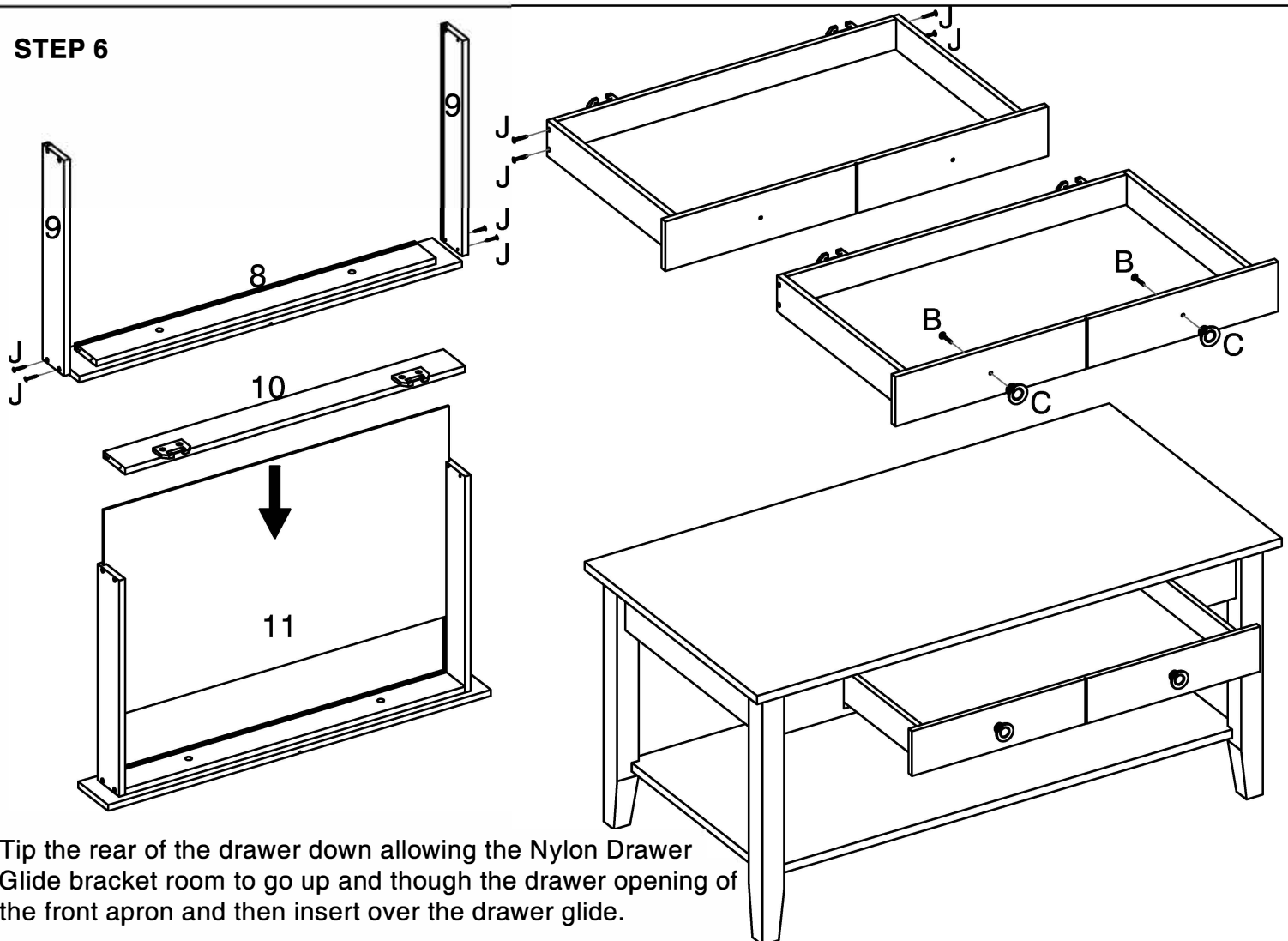

Tip the rear of the drawer down allowing the Nylon Drawer Glide bracket room to go up and through the drawer opening of the front apron and then insert over the drawer glide.