

# Square End Table

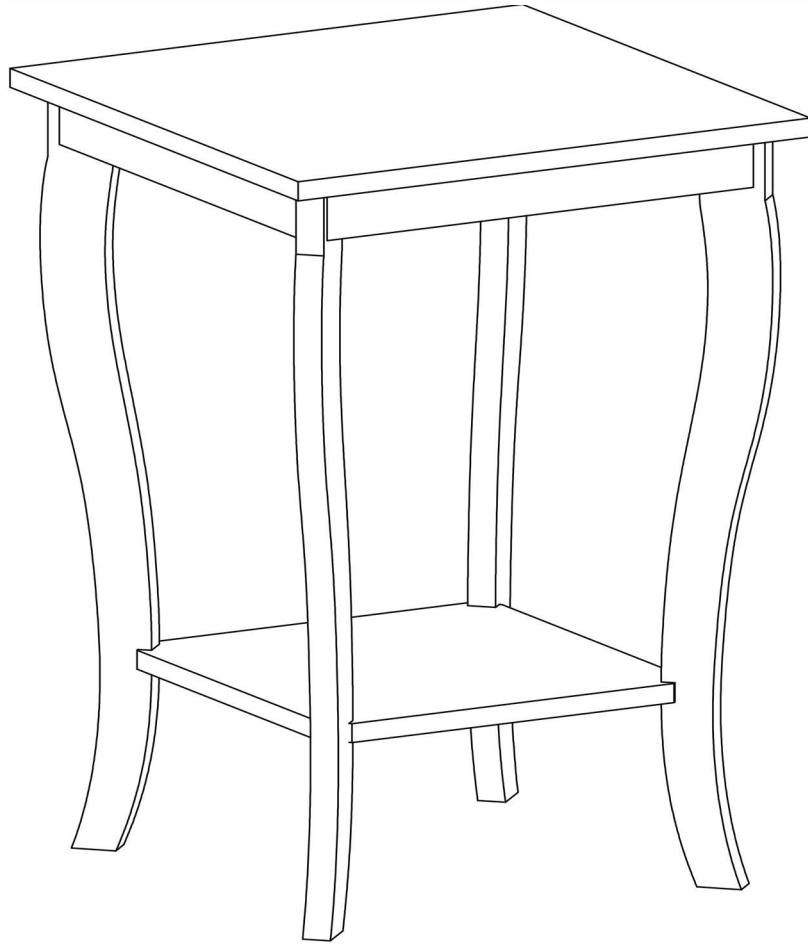

## Assembly instructions

We have designed our furniture with you, the customer in mind. Our clear, easy to follow step by step instructions will guide you through the project from start to finish.

Feel confident that this will be a fun and rewarding project. The final product will be a quality piece of furniture that will go together smoothly and give years of enjoyment.

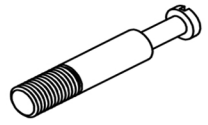
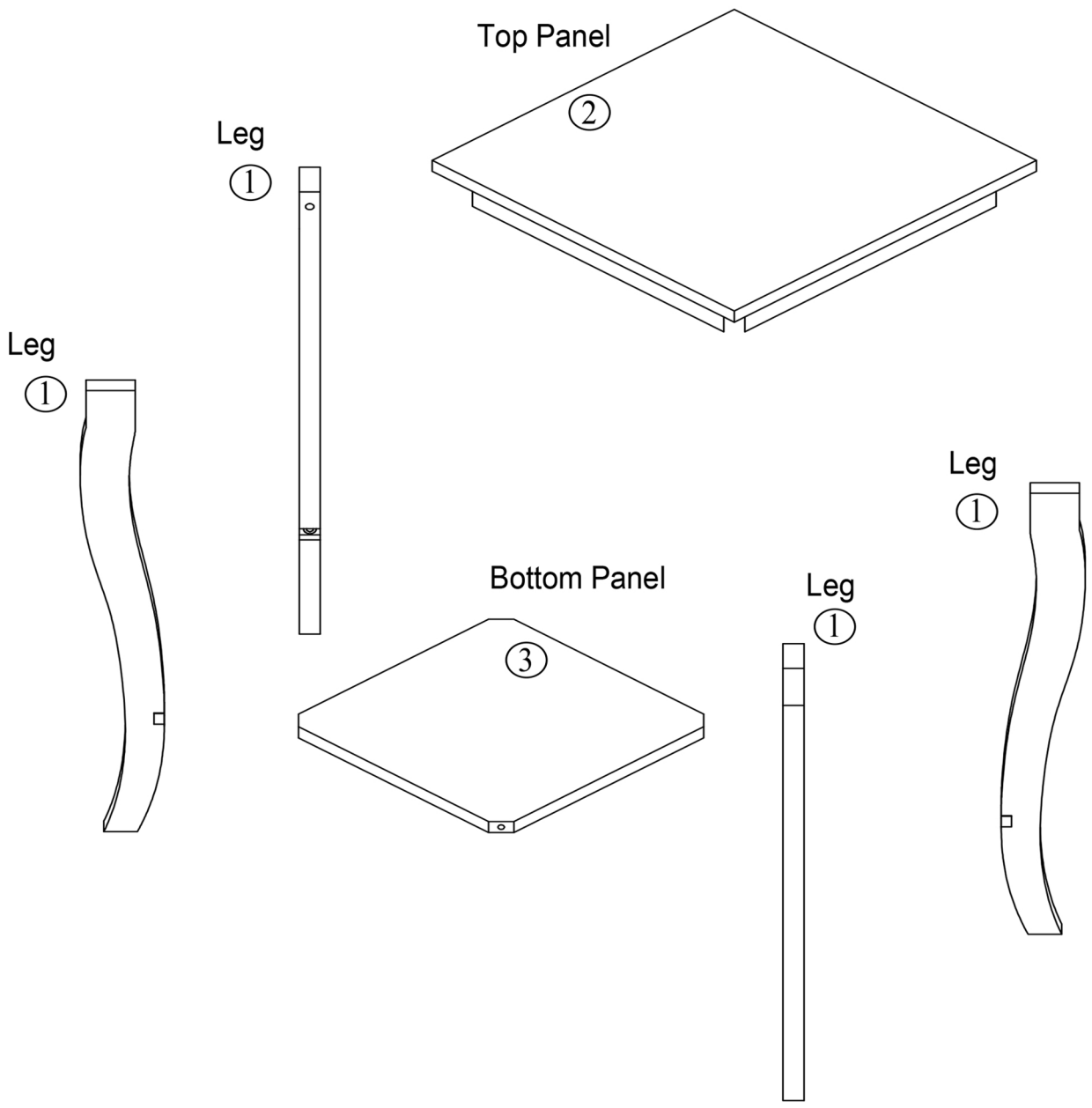

A. 4 pcs  
Cam Bolt



B. 4 pcs  
Cam Lock

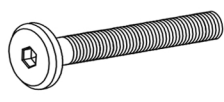

C. 4 pcs  
Bolt



D. 4 pcs  
Lock Washers

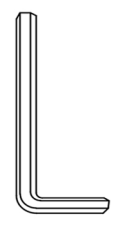

E. 1 pc  
Allen Wrench

Assembling the unit with cams .

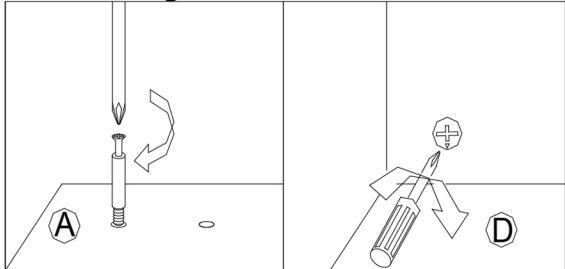

Gently screw cam bolt into the threaded anchor.

Insert cam lock with arrow pointing down. Screw the cam firmly into locked position.

## STEP 1

\*\*\*Arrow On Cam Lock Faces Outward Opening.

HARDWARE  
NEEDED

A x 4
B x 4

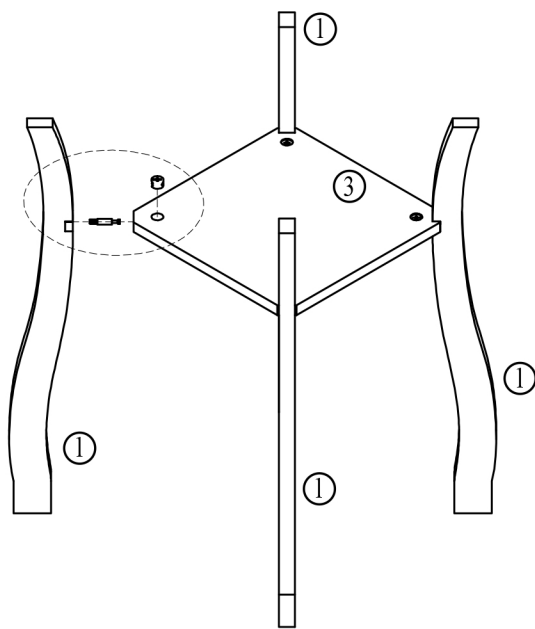
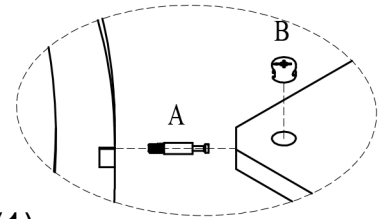

- 1.) Screw Cambolts (B) into Leg (1).
- 2.) Place CamLocks (A) into Bottom Panel (3).
- 3.) Insert Legs into Bottom Panel and lock into position by turning Camlocks clockwise.

\*\*\*Turn only 1/4 of the way for locked position.

## STEP 2

HARDWARE  
NEEDED

C x 4
D x 4
E x 1

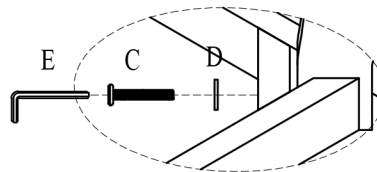

- 1.) Place Leg Assembly into Top Panel (2).
- 2.) Assemble Bolt (C) with Lock Washer(D) in order as shown.
- 3.) Using Allen Wrench (E) , fasten Bolt Assembly to secure the Top panel to the Leg Assembly.

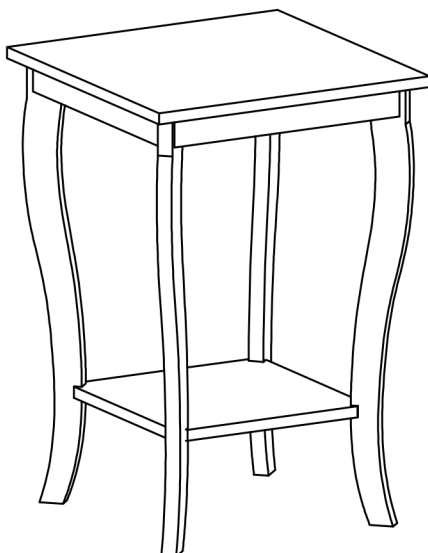
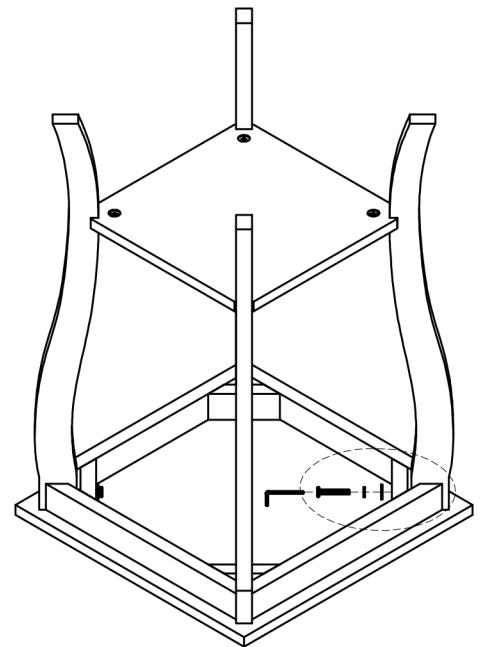

## STEP 3

Turn Over and Enjoy you new quality piece of furniture for years to come