

Aluminium Greenhouse

ASSEMBLY INSTRUCTIONS

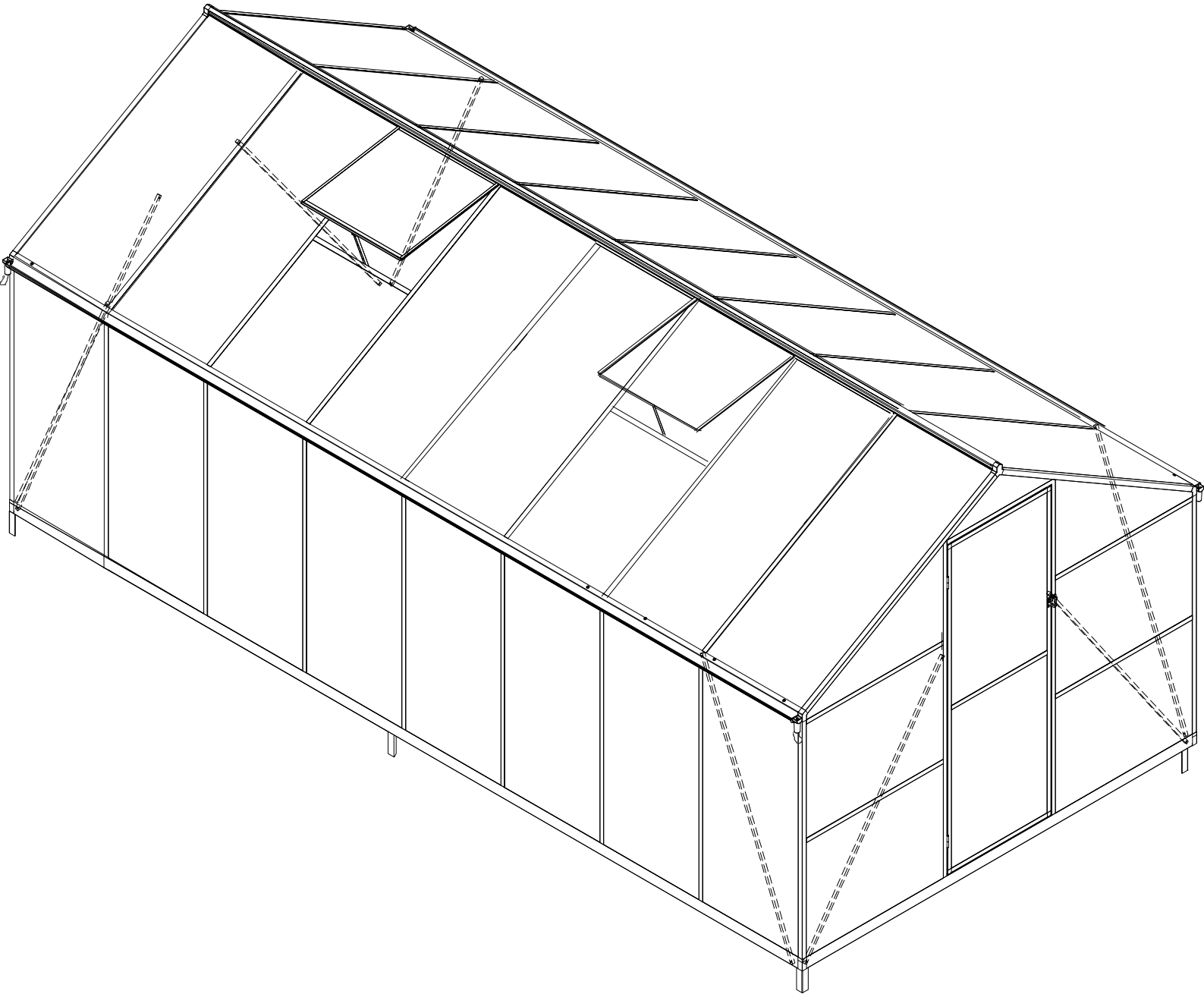

Please read all instructions carefully before assembly.
It is best to familiarize yourself with the parts and
collate the appropriate parts for each step.



VIWATCustomerService@gmail.com

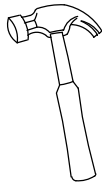
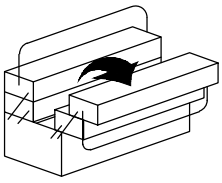





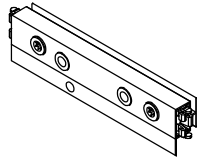
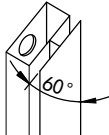
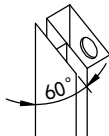
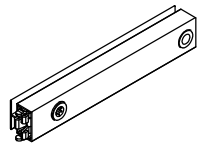
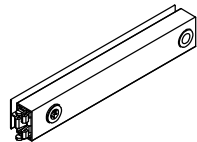
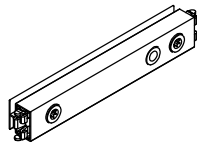
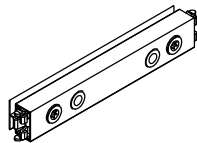
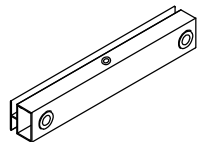
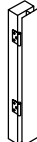

Aluminum Parts:

No.	Picture	Qty.
A1-1		x2
A1-2		x2
A2-1		x2
A2-2		x2
A2-3		x2
A3-1		x2
A3-2		x2
A3-3		x2
A4-1		x2
A4-2		x1

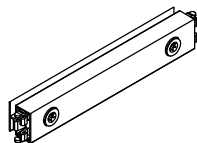
No.	Picture	Qty.
A5-1		x2
A5-2		x2
A6-1		x1
A6-2		x1
A7-1		x1
A7-2		x1
A8-1		x1
A8-2		x1
A9		x1
A10-1		x2

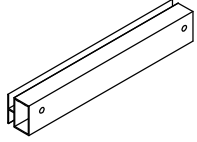
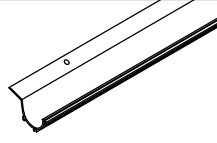
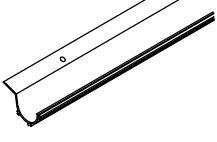
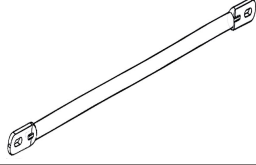
Aluminum Parts :

No.	Picture	Qty.
A10-2		x2
A11-1		x1
A11-2		x1
A12		x4
A13		x4
A15		x14
A16		x10
A17		x2
A18-1		x1
A18-2		x1
A19		x1

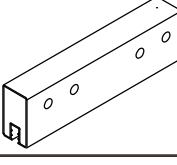
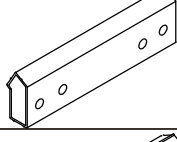
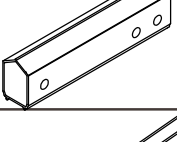
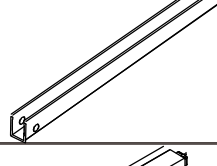
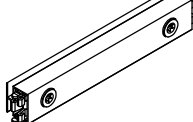
No.	Picture	Qty.
A20		x2
A21		x4
A21-1		x2
A23		x8
A25-1		x7
A25-2		x14
A25-3		x4
A26		x6
A27		x4
A28		x2
A30-2		x2
A31		x1

Plastic Parts:



No.	Picture	Qty.
H1		x4
H2-1		x2
H3-1		x2





No.	Picture	Qty.
H4		x2
H5		x2
C5		x4

Hardware:

No.	Picture	Qty.	Size
H6		x34	M6x30
H7		x1	
H8		x106	M6x12
H9		x50	M6
H11		x22	ST4x10
H12		x4	ST5x10
H13		x18	ST5x16
H14		x1	

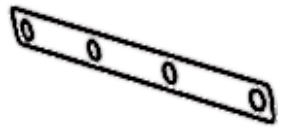

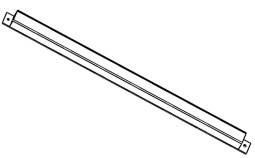
No.	Picture	Qty.	Size
H15		x1	
H16		x2	
H17		x4	
H18		x24	M6x20
H19		x4	
H20		x2	M4x38
A30-1		x2	

Hardware :

No.	Picture	Qty.
C1		x4
C2		x2
C3-1		x2
C6		x14
C7		x4
C8		x2

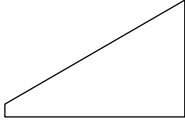
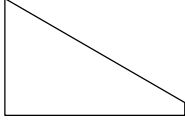
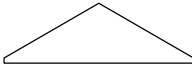
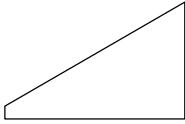
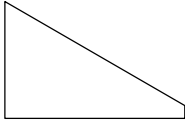
Twin PC Board:

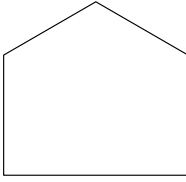
No.	Picture	Qty.
B1		4
B2		4
B3		16
B4		14
B5		2
B6		2
B7-1		1
B7-2		1
B8		1
B9-1		1
B9-2		1

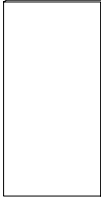
No.	Picture	Qty.
B10		1
B11		2
B12		1

The white film faces outwards if applicable.

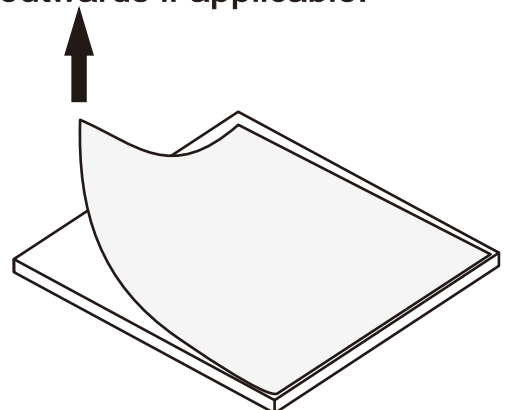

ROOF SECTION

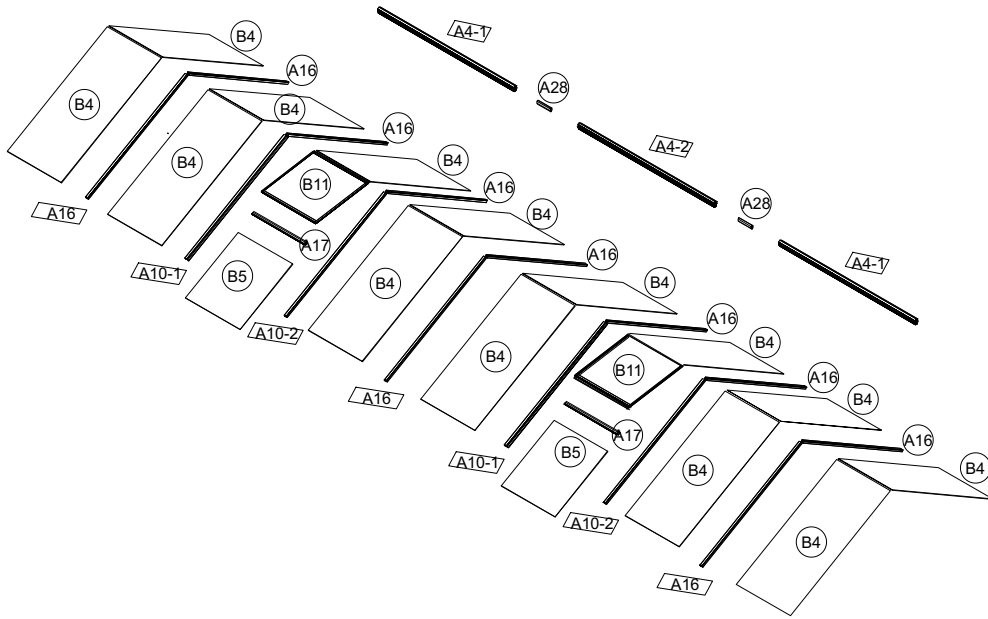

WALL SECTION

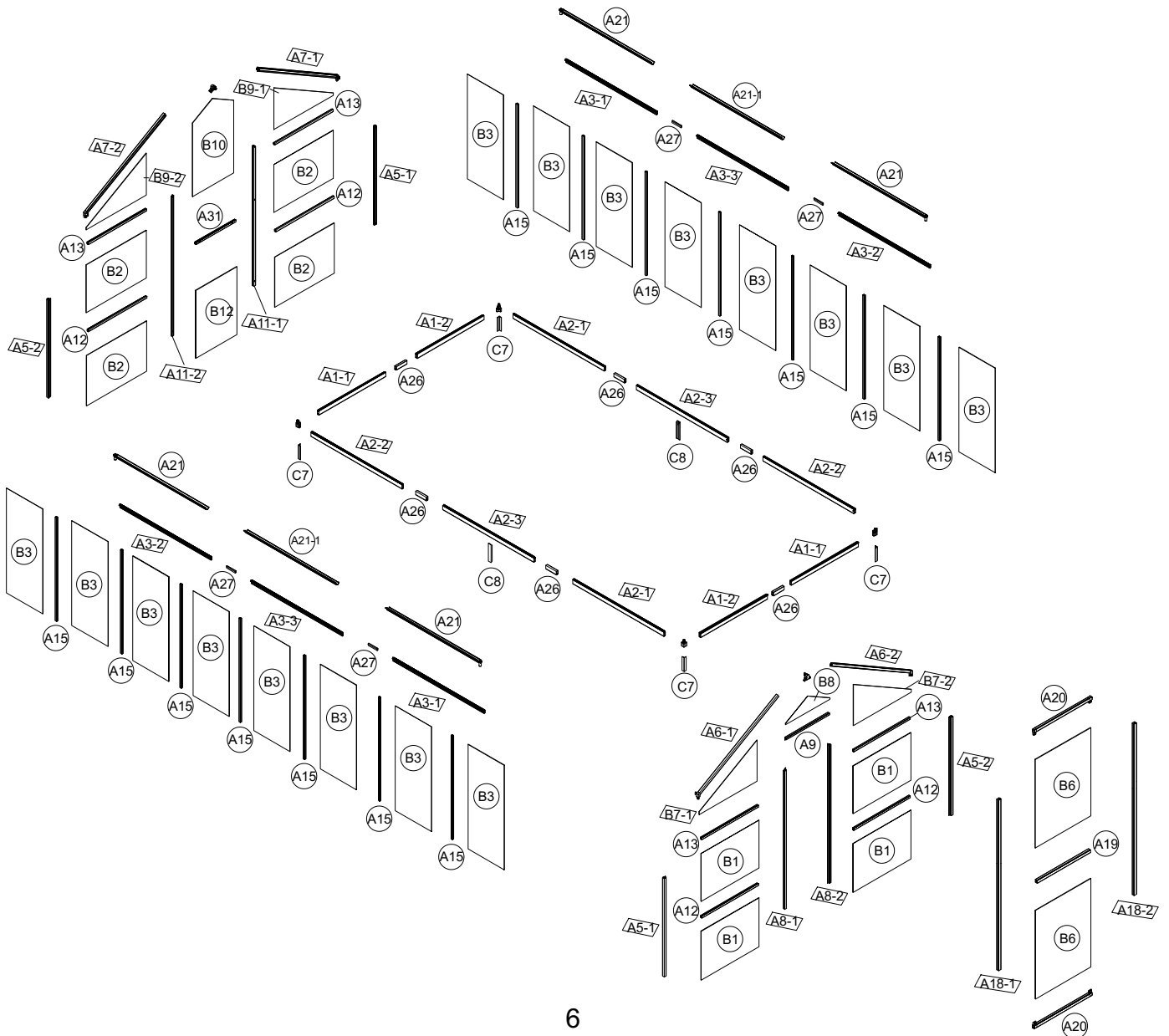

Picture	NO.	Qty.
	A1-1	x2
	A1-2	x2
	A2-1	x2
	A2-2	x2
	A2-3	x2
	C7	x4
	C8	x2
	A26	x6

Picture	NO.	Qty.
	H1	x4
	H6	x24
	H8	x12
	H9	x24

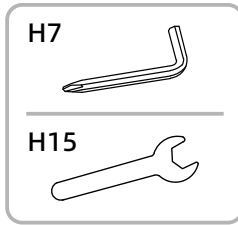

Please merge the fittings until there is no gap before tightening the screws.

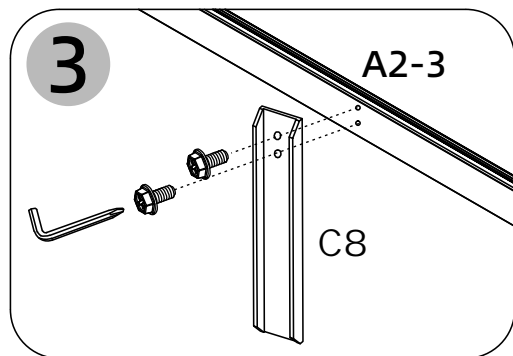
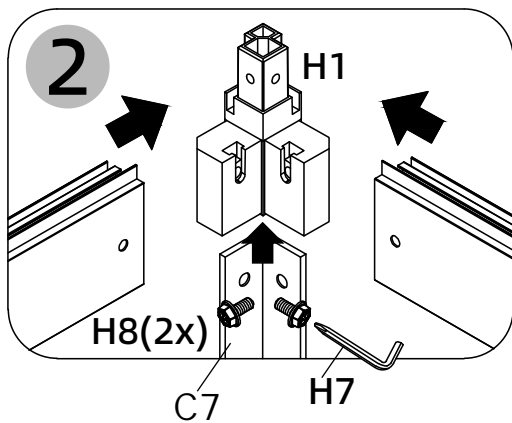
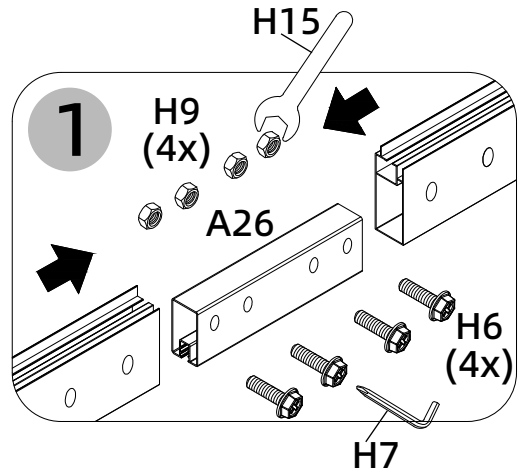
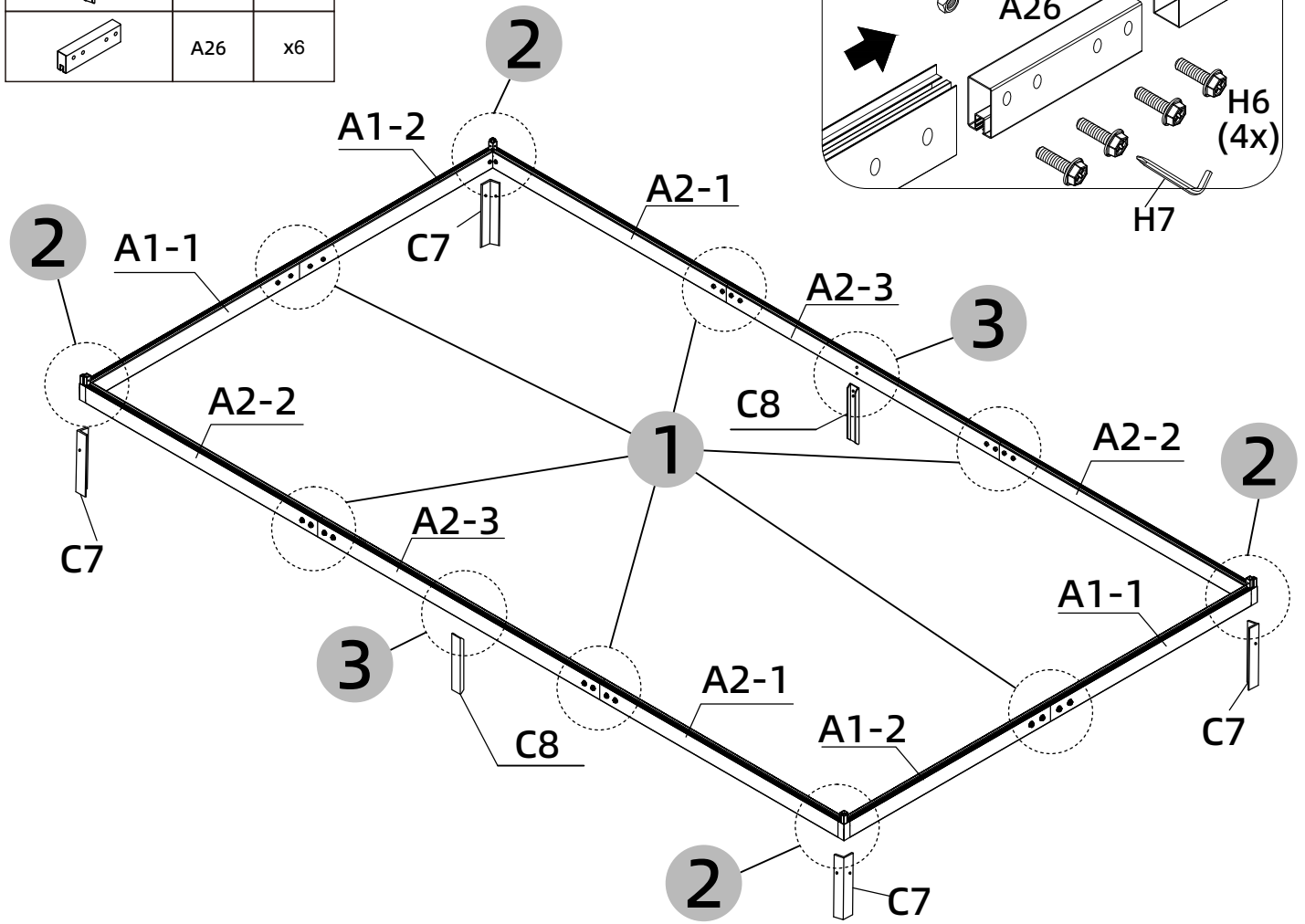

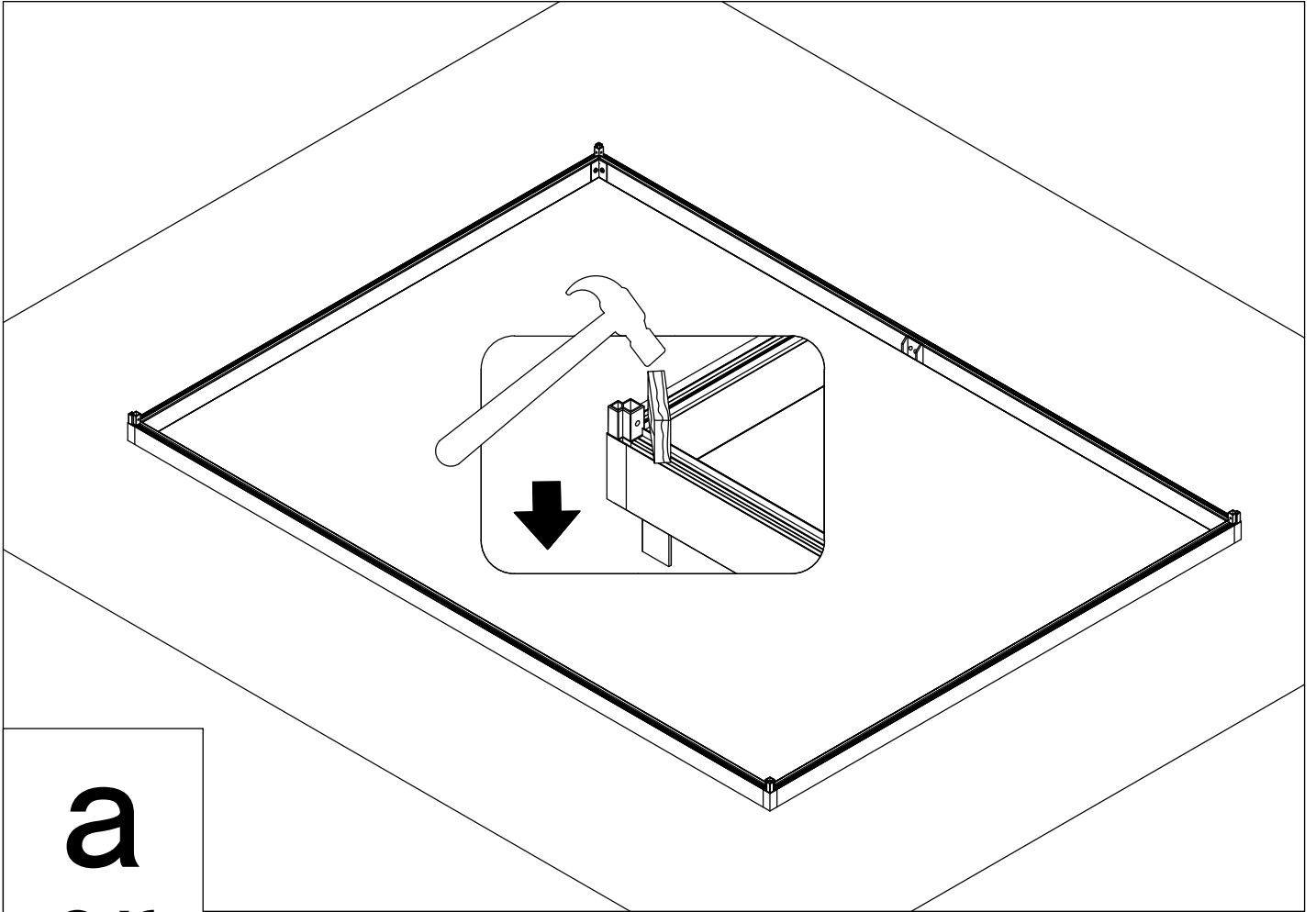

a
or
b

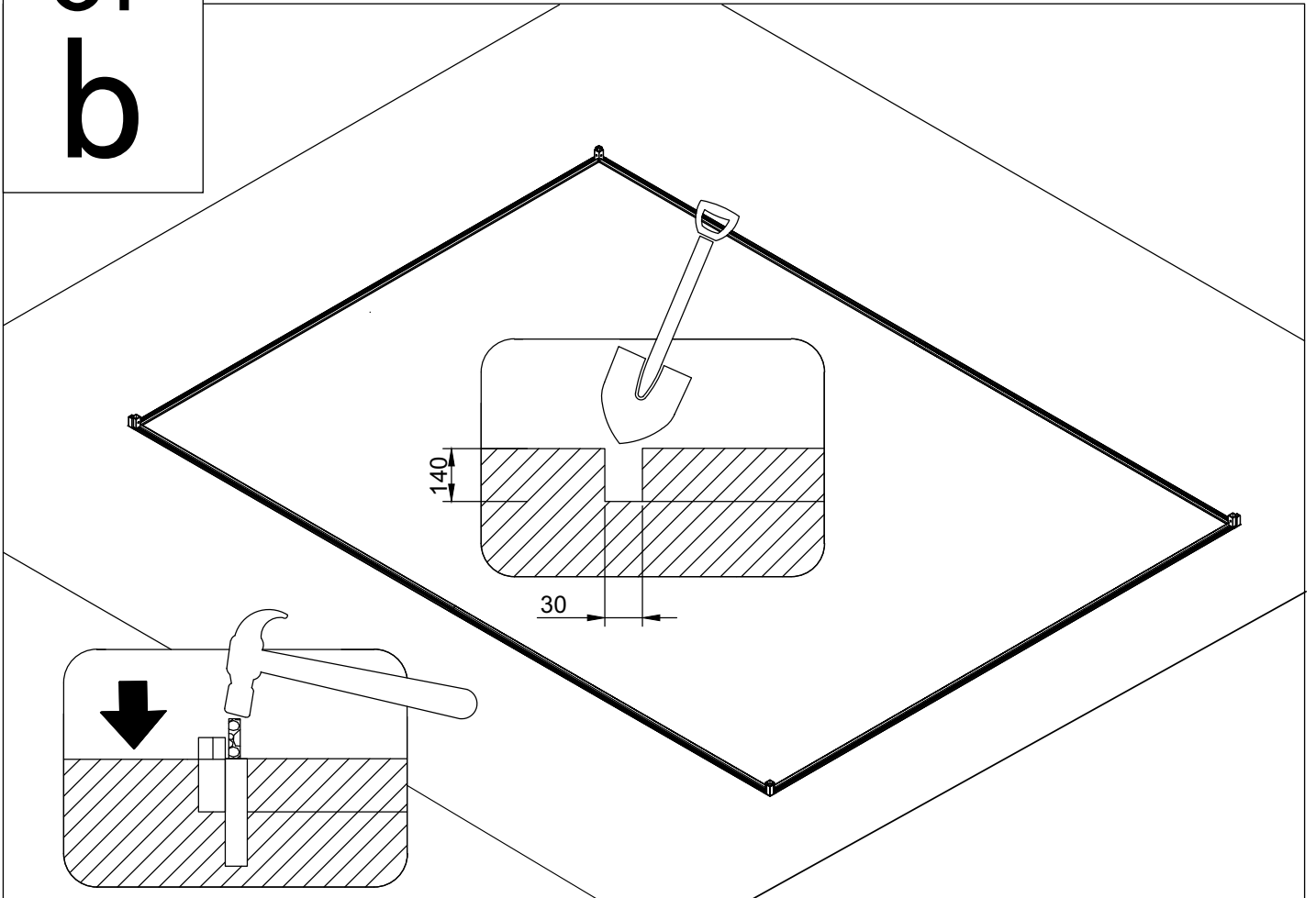

Picture	NO.	Qty.
	A5-1	x2
	A5-2	x2
	A8-1	x1
	A8-2	x1
	H8	x4
	B1	x2

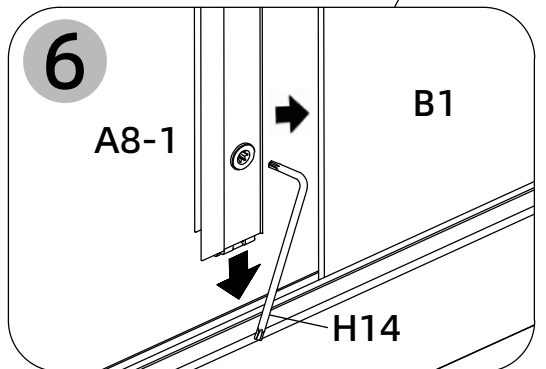
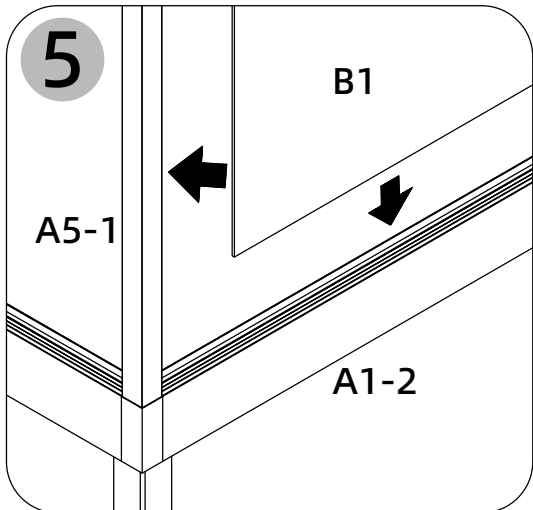
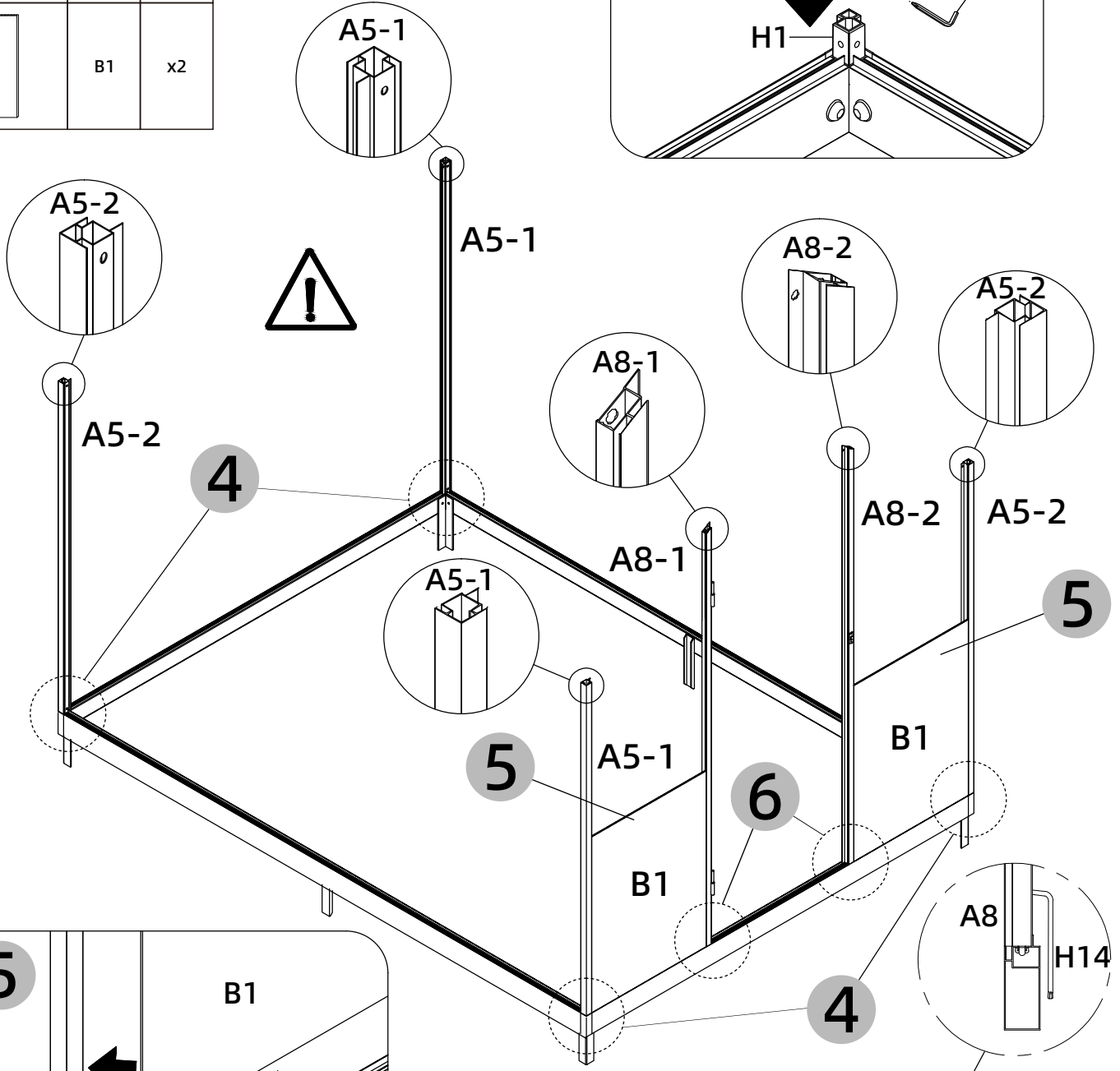
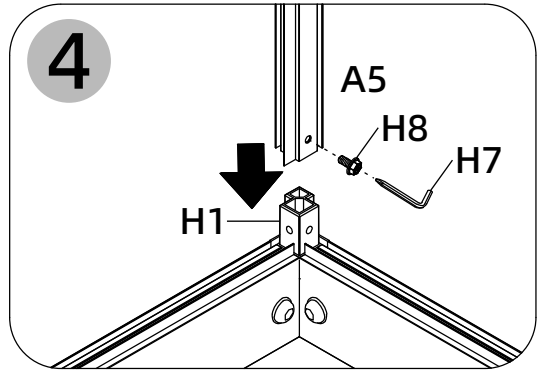
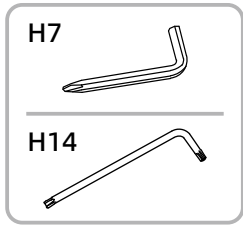

Picture	NO.	Qty.
	A12	x2
	H8	x2
	B1	x2

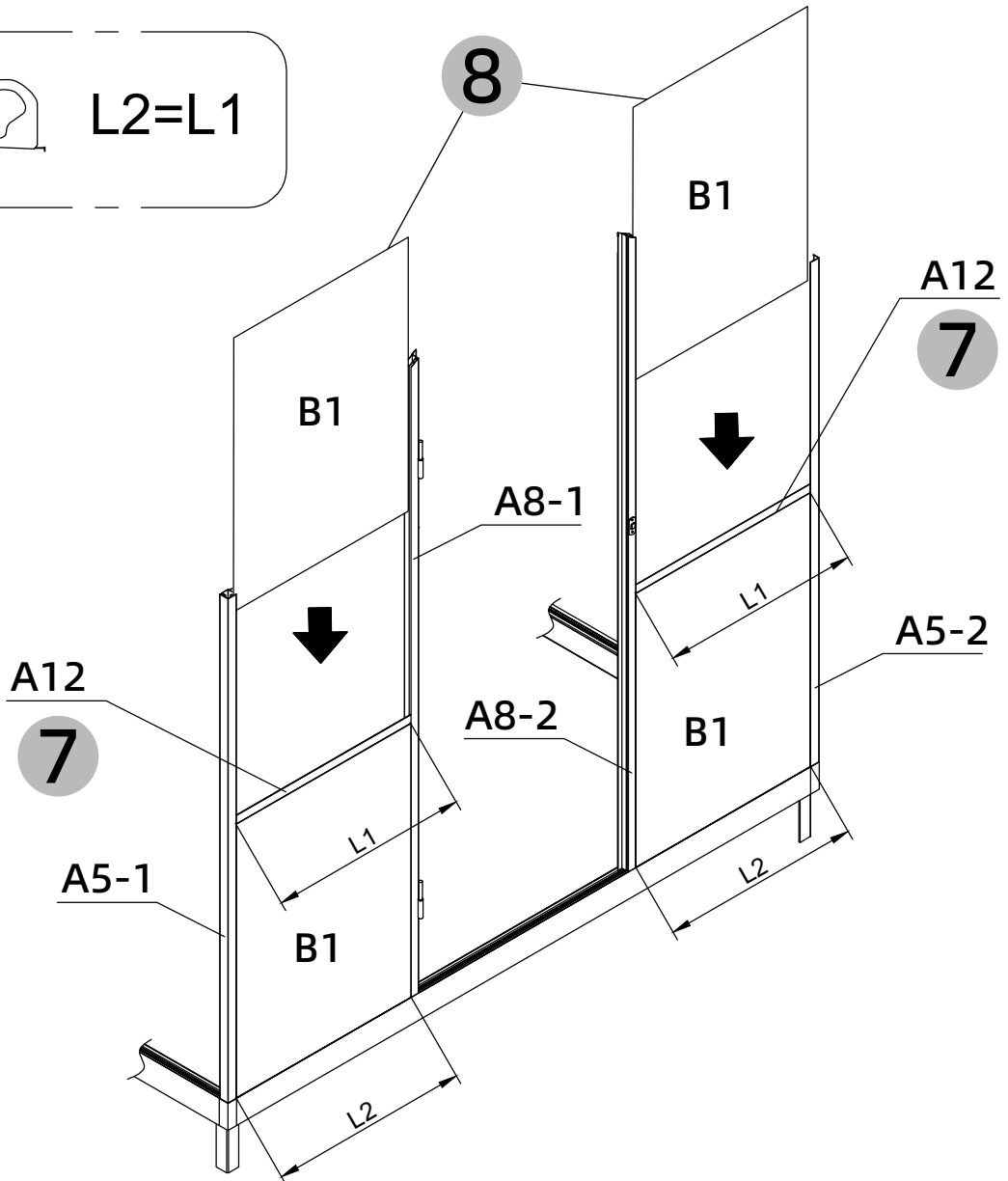
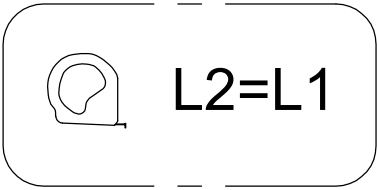
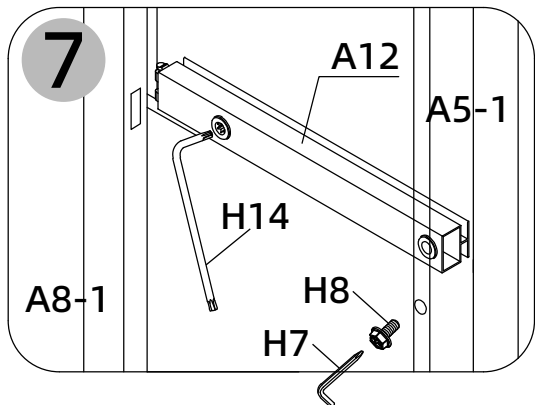
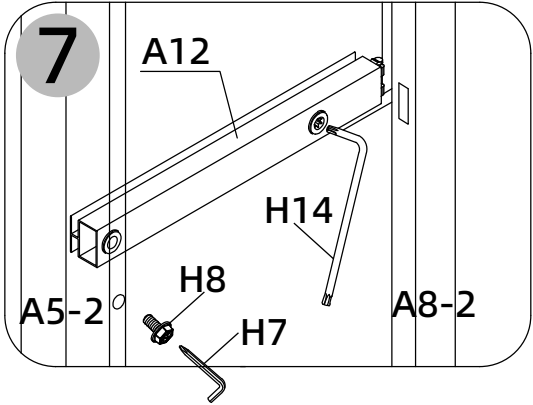
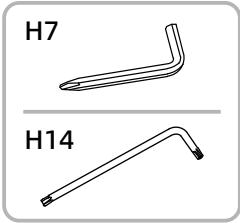

Picture	NO.	Qty.
	A9	x1
	A13	x2
	H8	x4
	B7-1	x1
	B7-2	x1
	H2-1	x1
	H18	x2

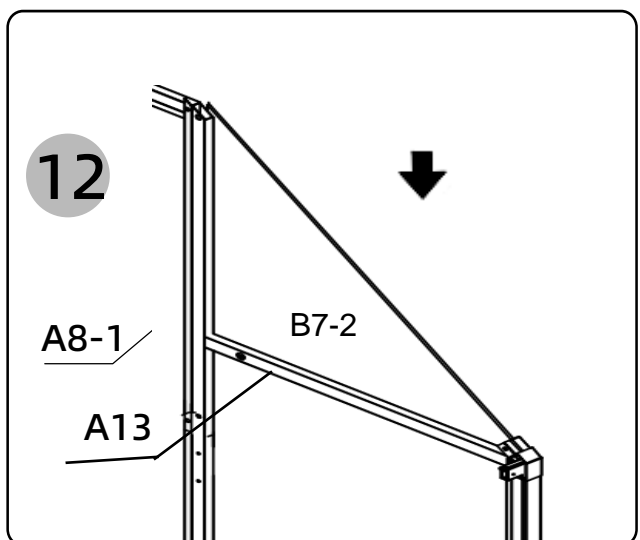
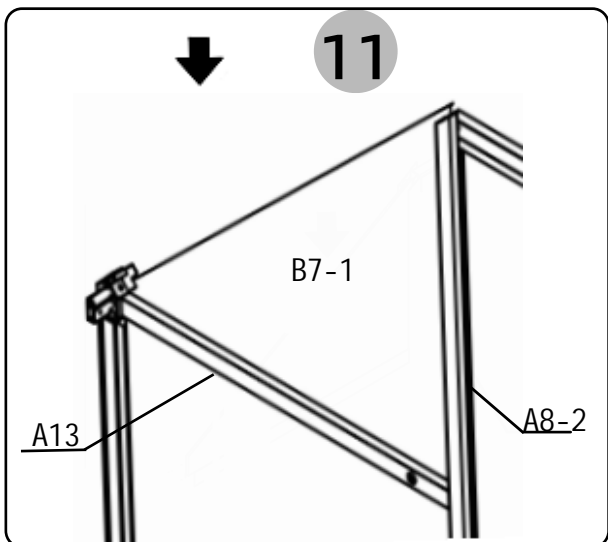
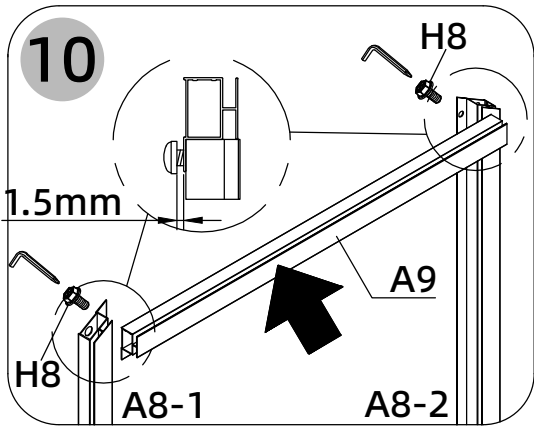
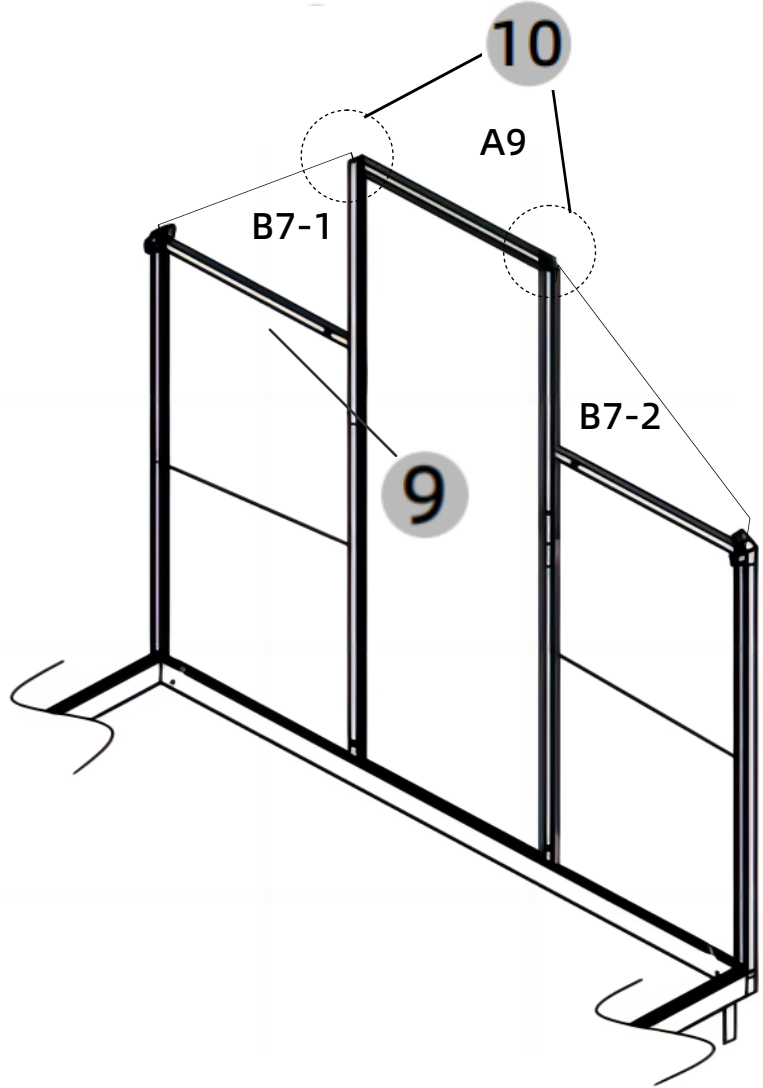
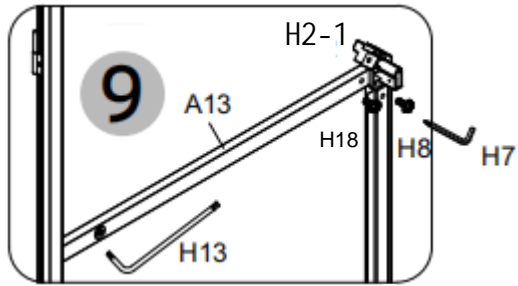
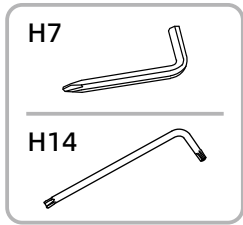

Picture	NO.	Qty.
	A6-1	x1
	A6-2	x1
	H3-1	x1
	H8	x2
	C2	x1

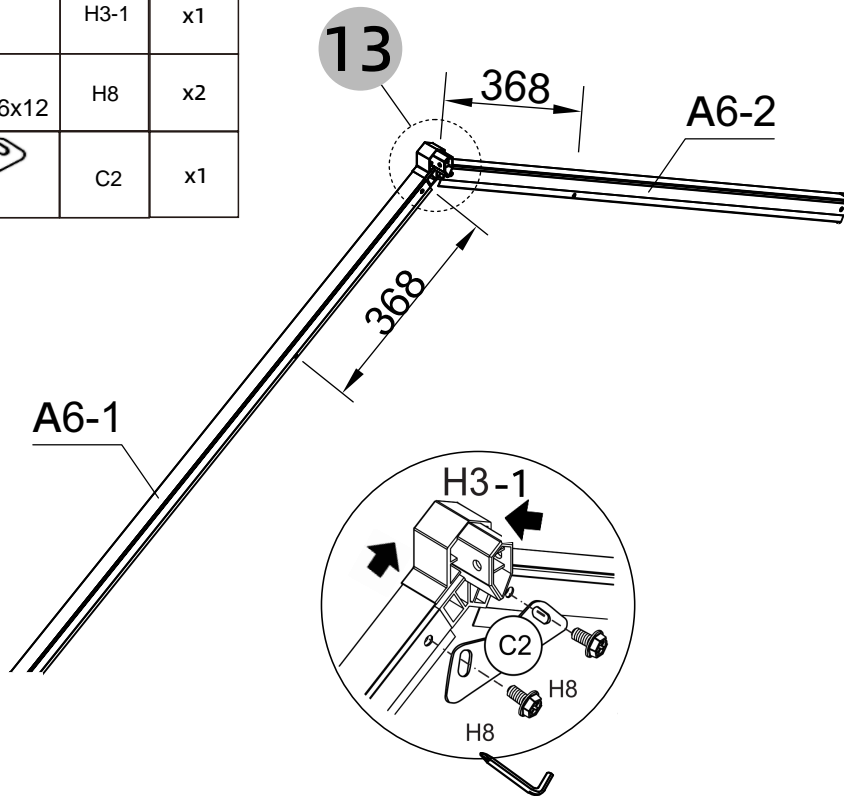
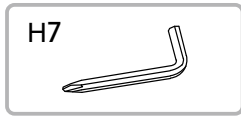

Picture	NO.	Qty.
	H8	x4
	B8	x1

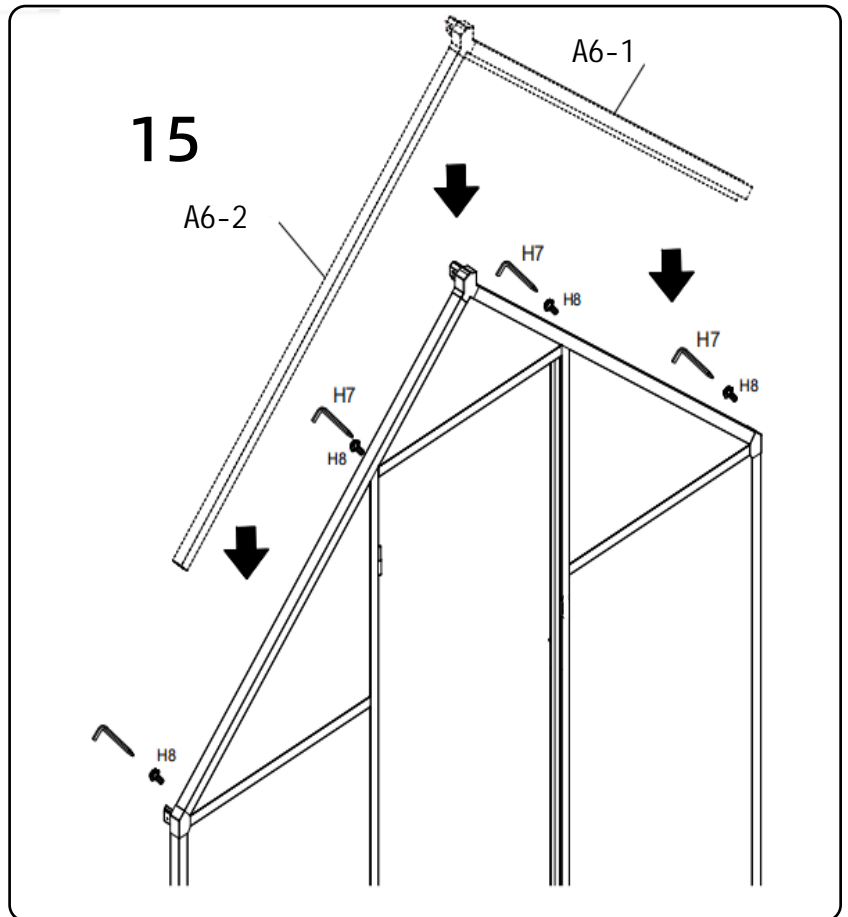
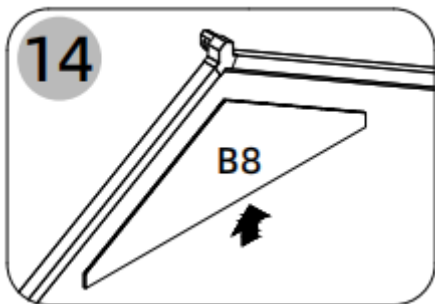

Picture	NO.	Qty.
	A11-1	x1
	A11-2	x1
	B2	x2

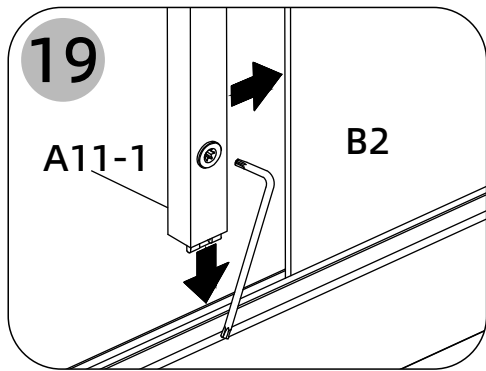
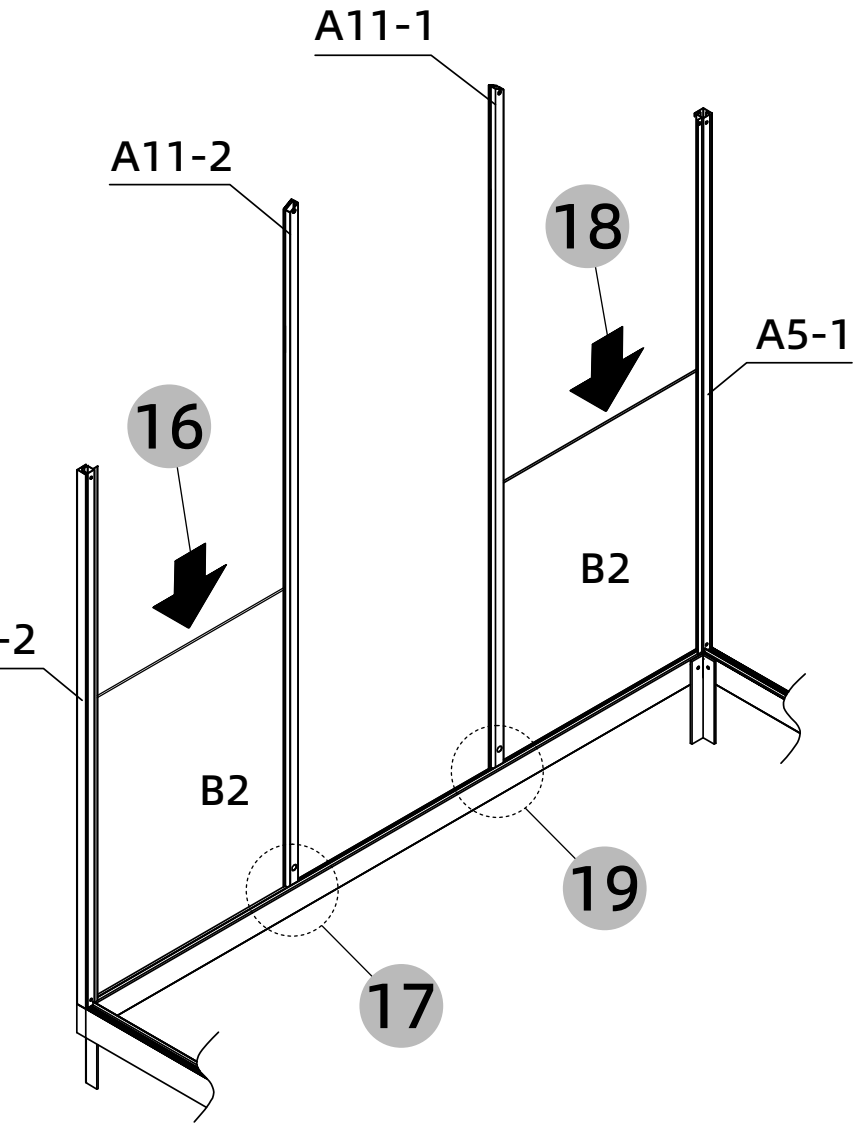
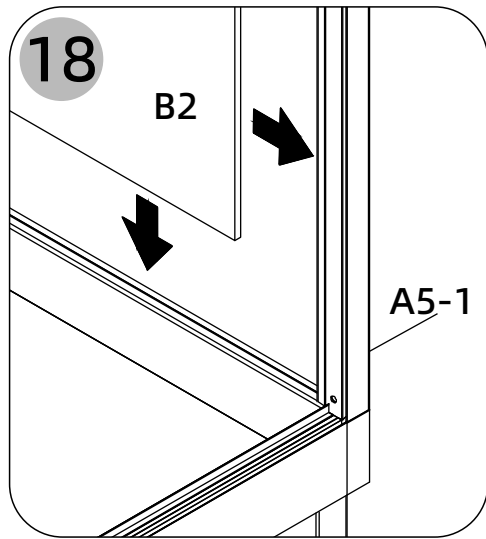
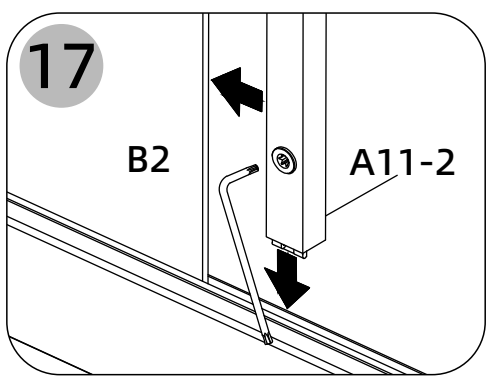
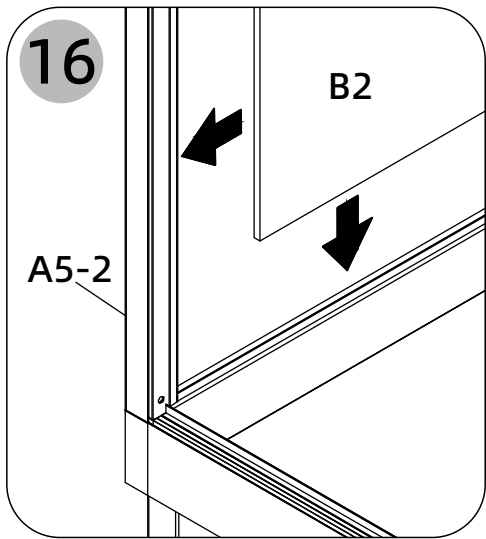

Picture	NO.	Qty.
	A12	x2
	A31	x1
	H8	x2
	B12	x1

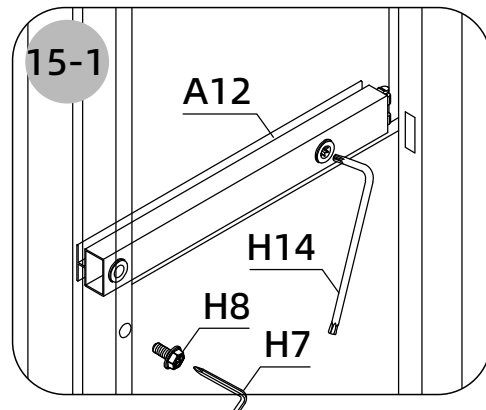
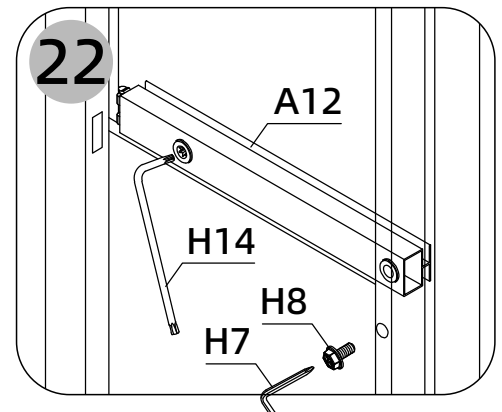
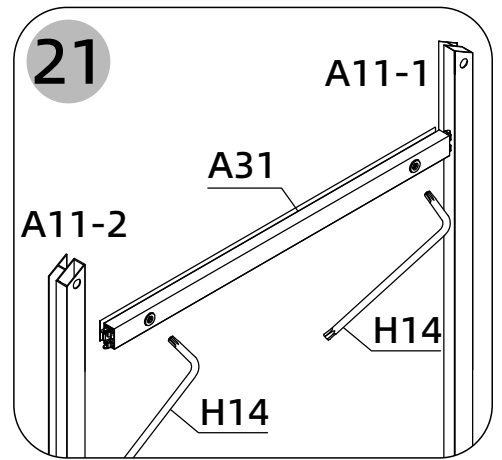
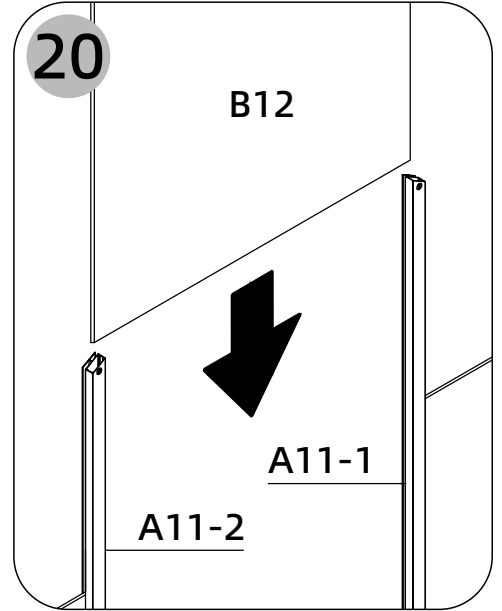
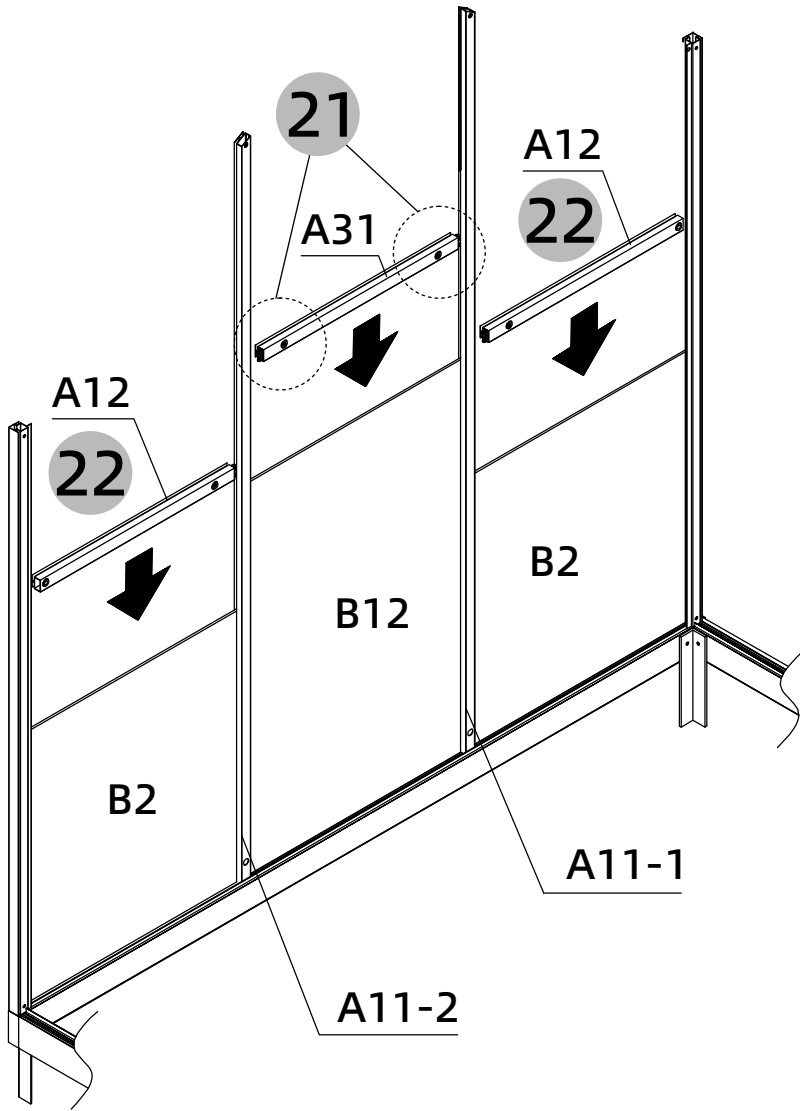
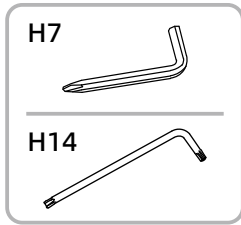

Picture	NO.	Qty.
	A13	x2
	H18	x2
	B2	x2
	B10	x1
	H2-1	x1

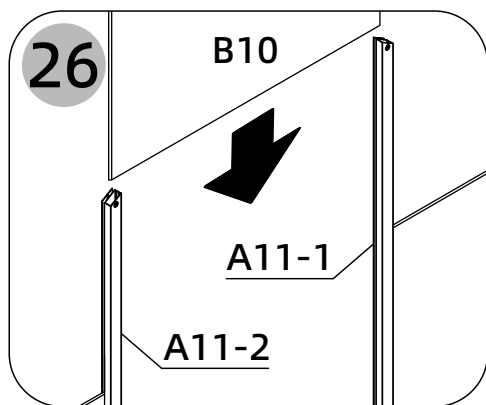
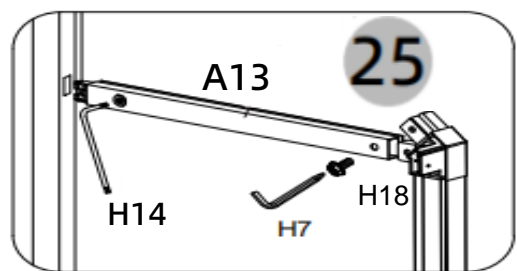
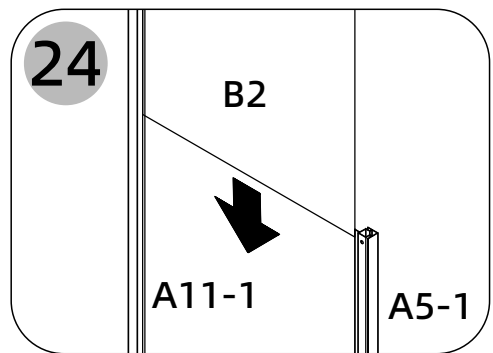
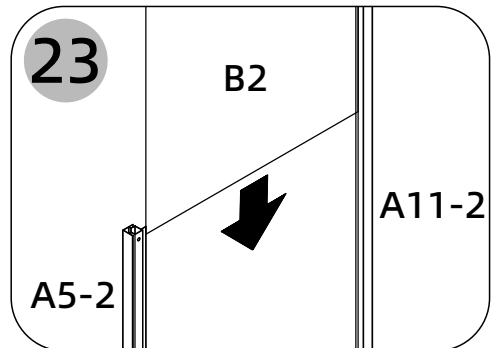
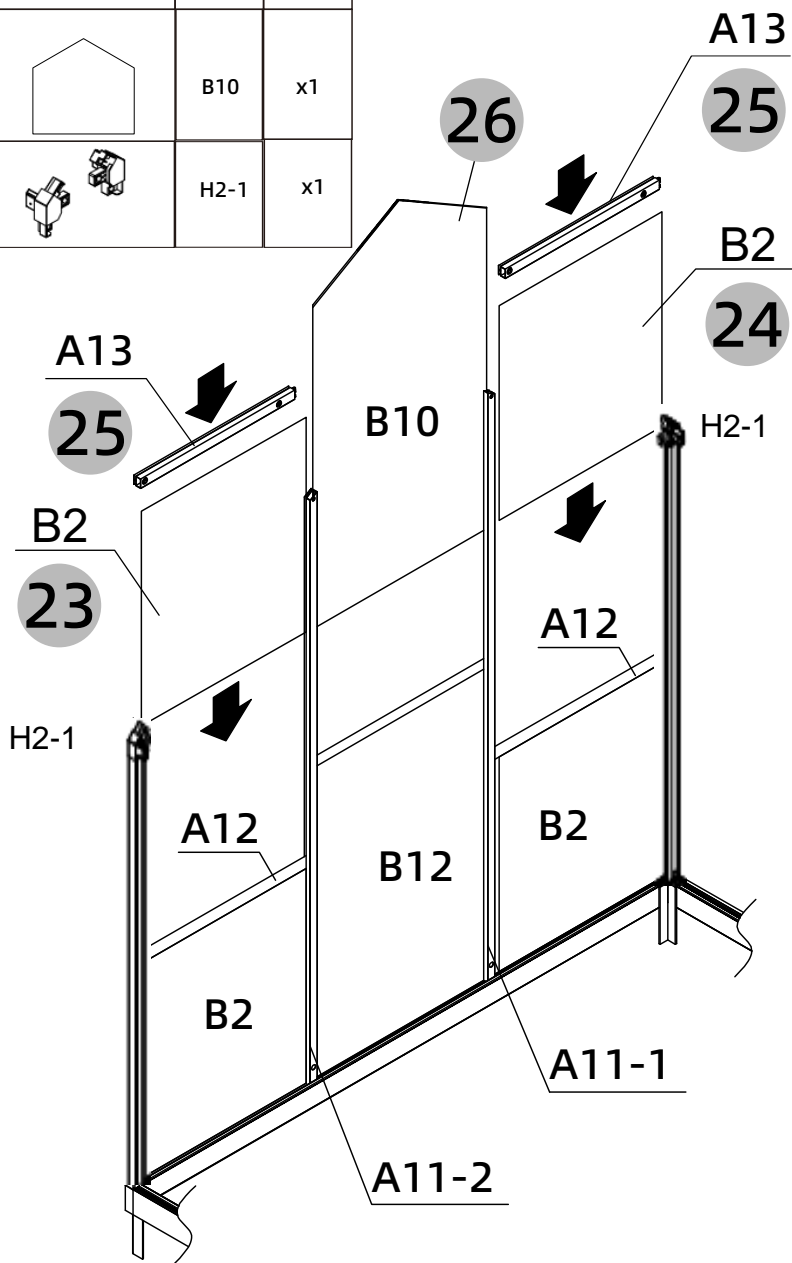
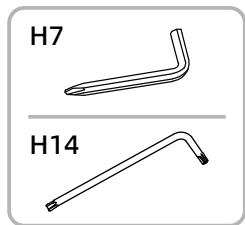

Picture	NO.	Qty.
	A7-1	x1
	A7-2	x1
	H3-1	x1
	H8	x2
	C2	x1

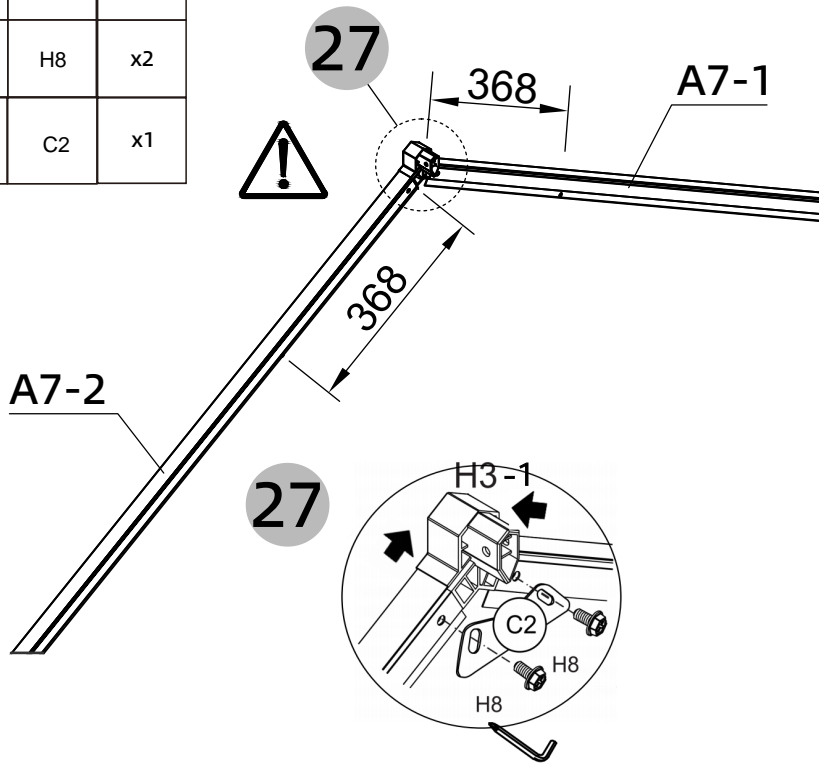
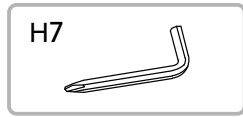

Picture	NO.	Qty.
	H8	x4
	B9-1	x1

Picture	NO.	Qty.
	B9-2	x1

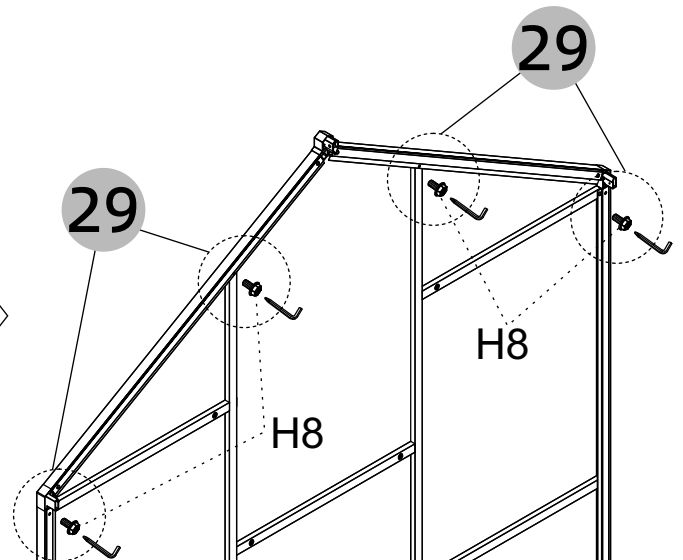
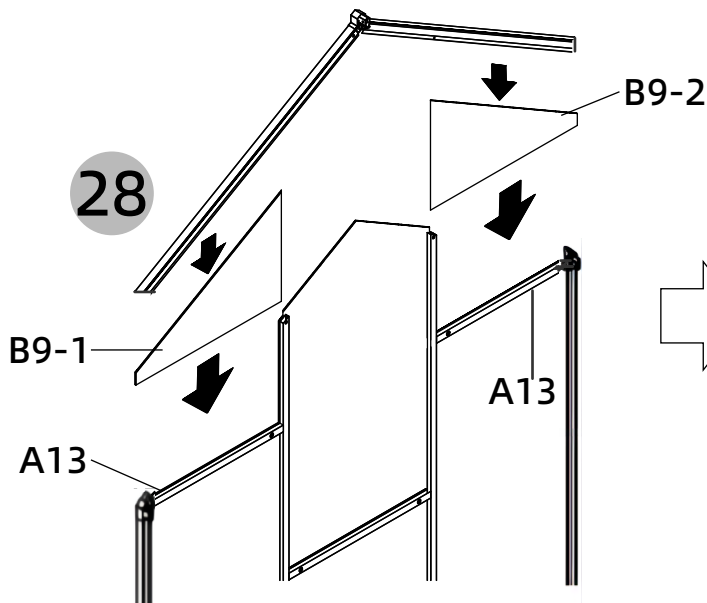
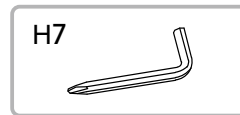



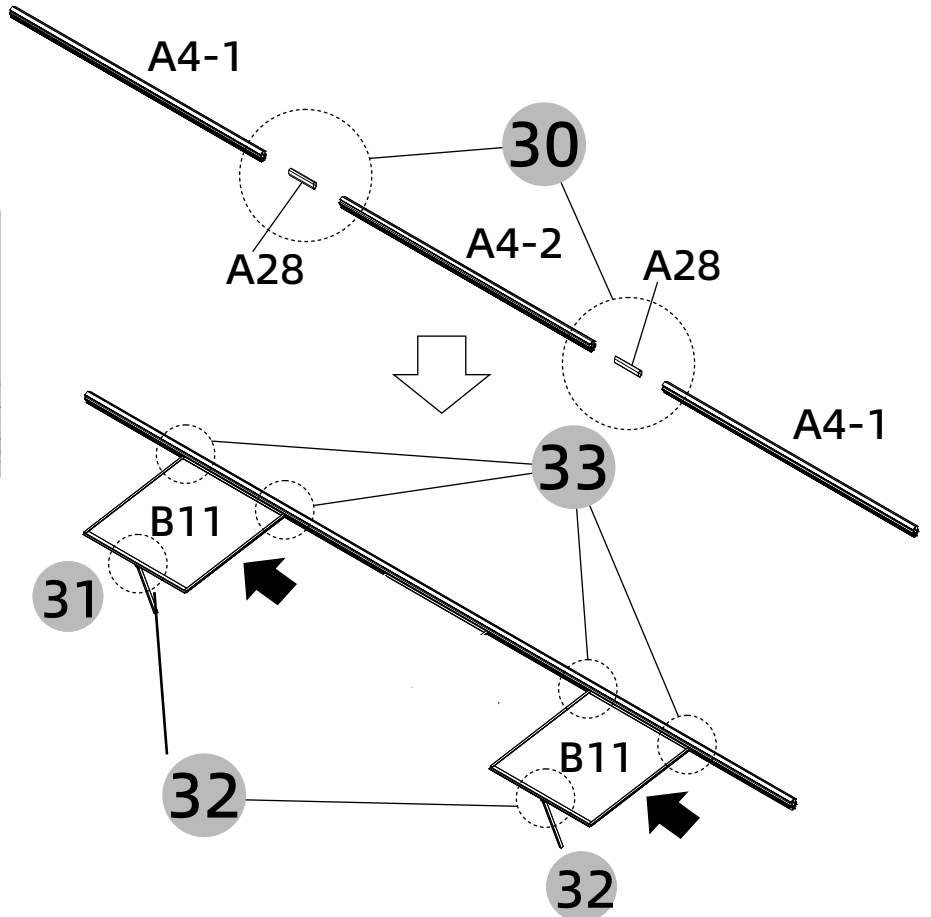
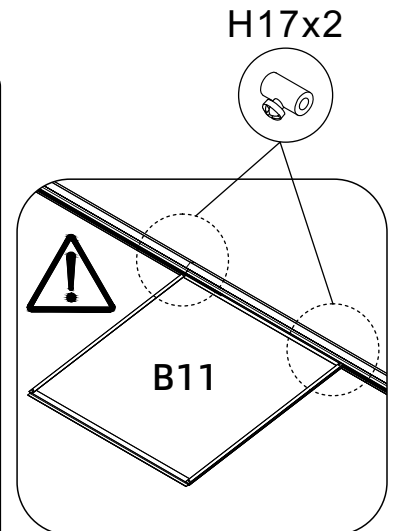
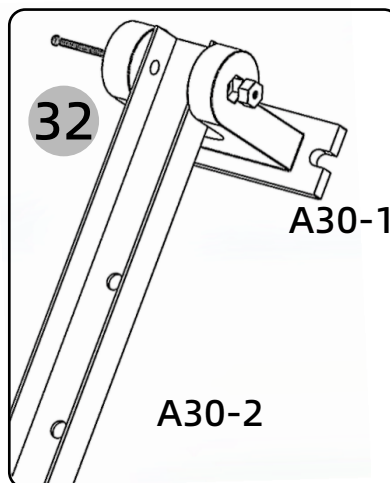
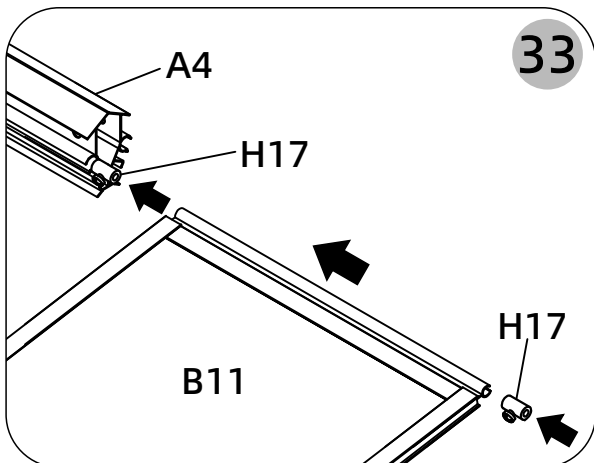
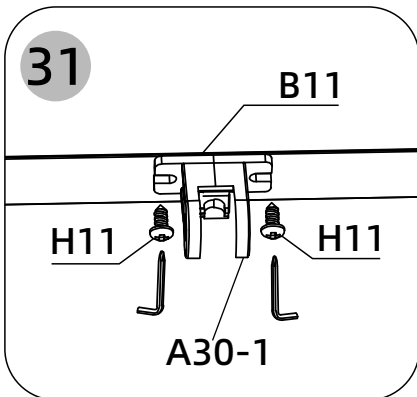
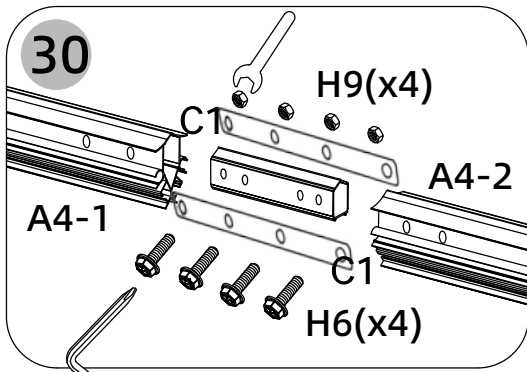
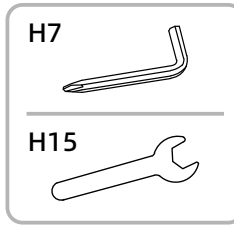

Picture	NO.	Qty.
	A4-1	x2
	A4-2	x1
	A28	x2
	A30-2	x2
	H6	x8
	H9	x8
	C1	x4

Picture	NO.	Qty.
	H11	x6
	H17	x4
	A30-1	x2
	B11	x2

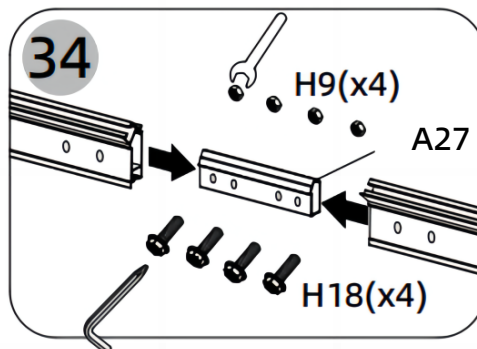
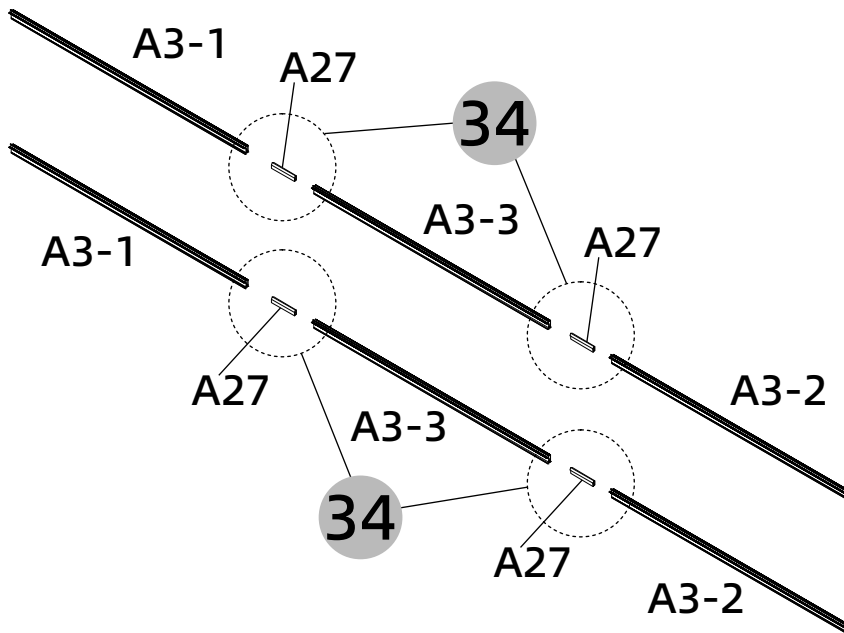
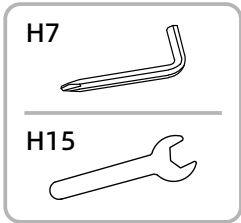



Picture	NO.	Qty.
	A3-1	x2
	A3-2	x2
	A3-3	x2
	A27	x4
 M6	H9	x16
 M6x20	H18	x16



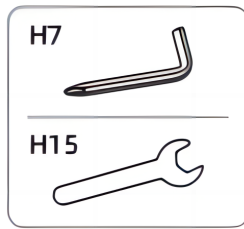

Picture	NO.	Qty.
 M6x30	H6	x2
 M6	H9	x2
 ST5x10	H12	x4

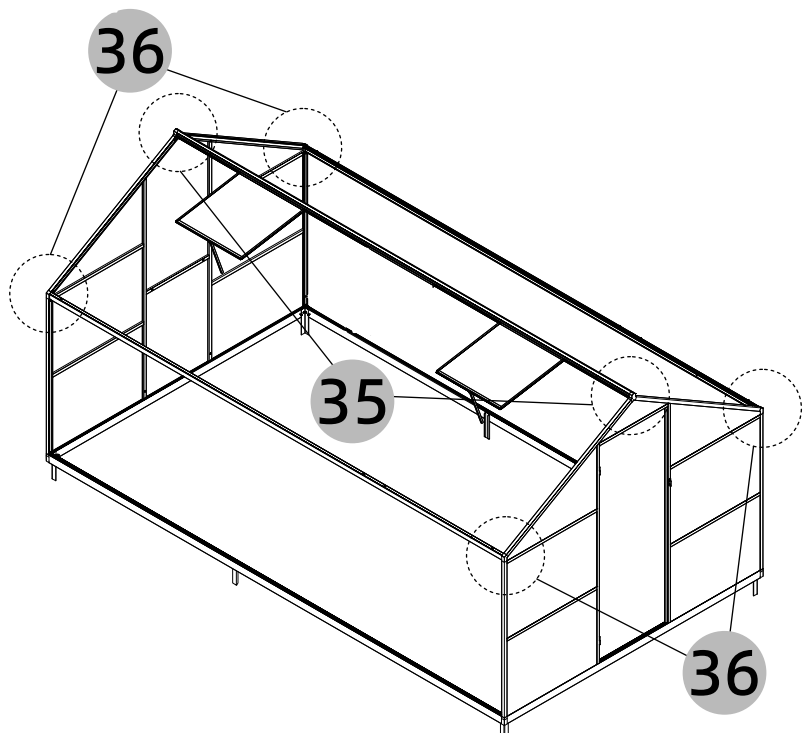
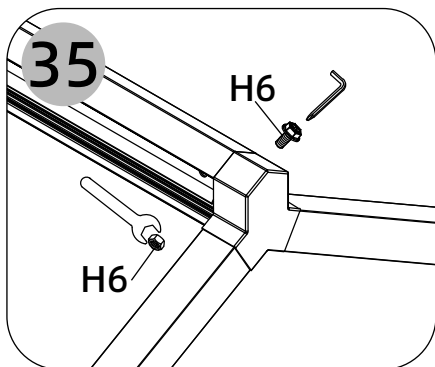
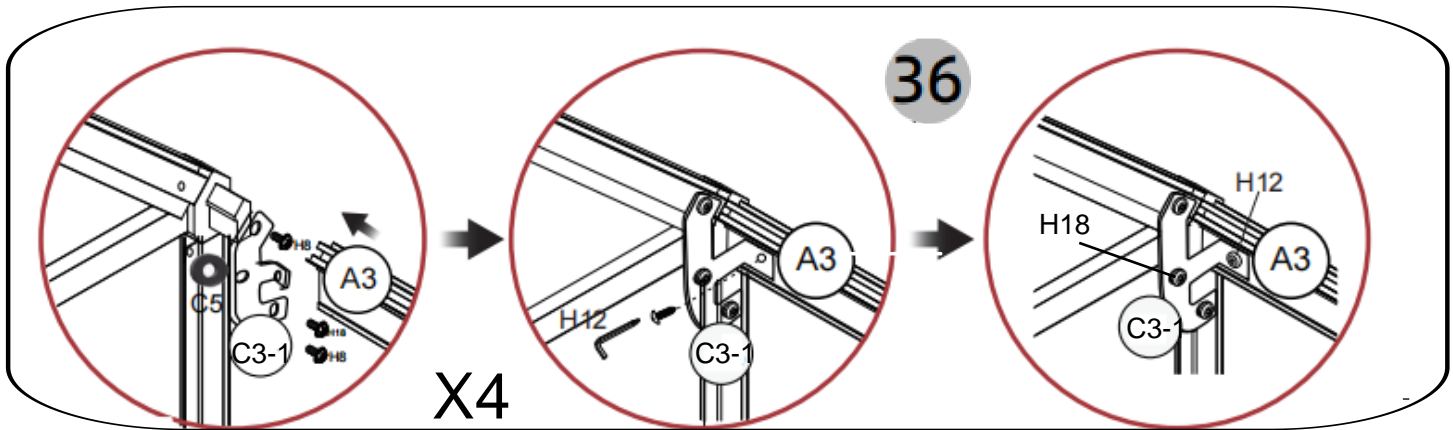

Picture	NO.	Qty.
	C3-1	x2
	C5	x4

To install the C3 -1 reinforcement, you need to loosen the previously installed H8 and H18 screws first

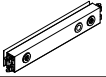

Picture	NO.	Qty.
	A15	x14
	B3	x16

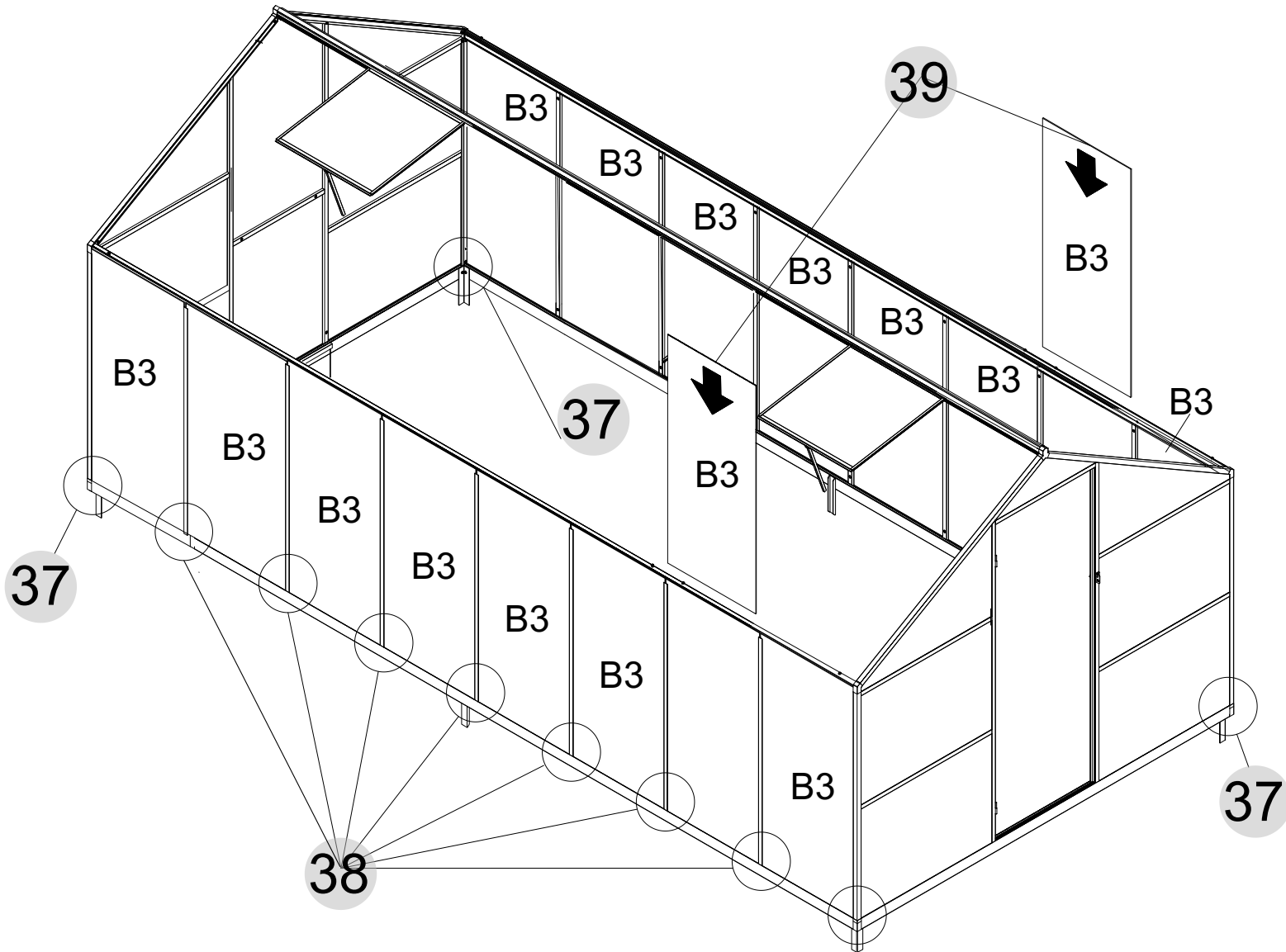
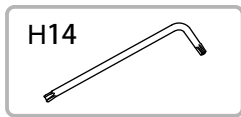

The installation position of PC board B3 is shown in the figure (outside of the aluminum profile)

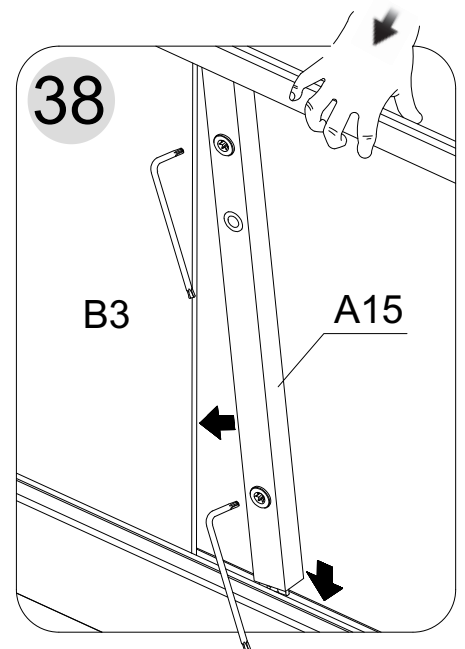
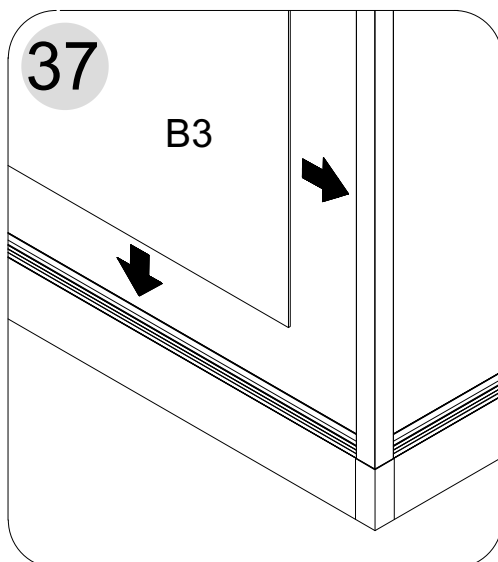
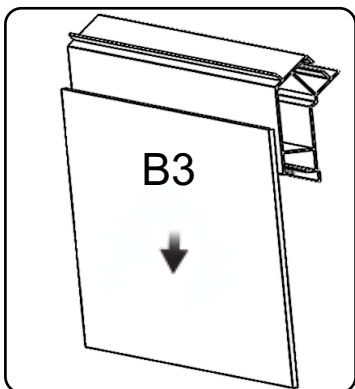

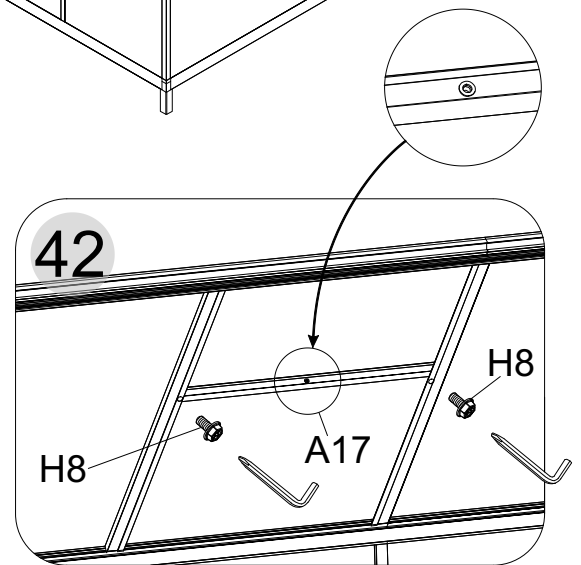
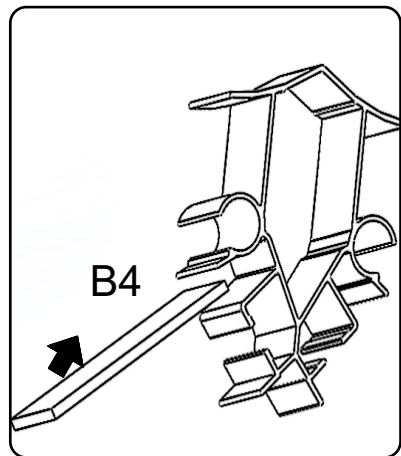
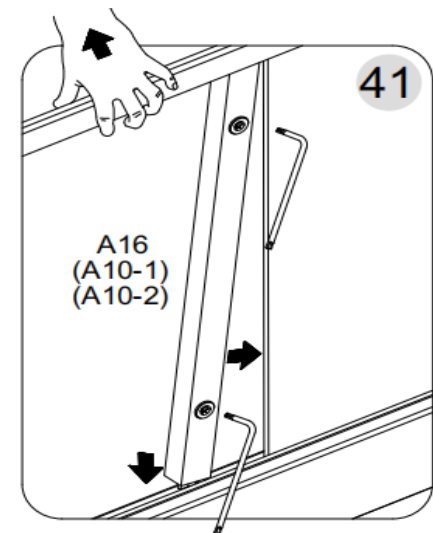
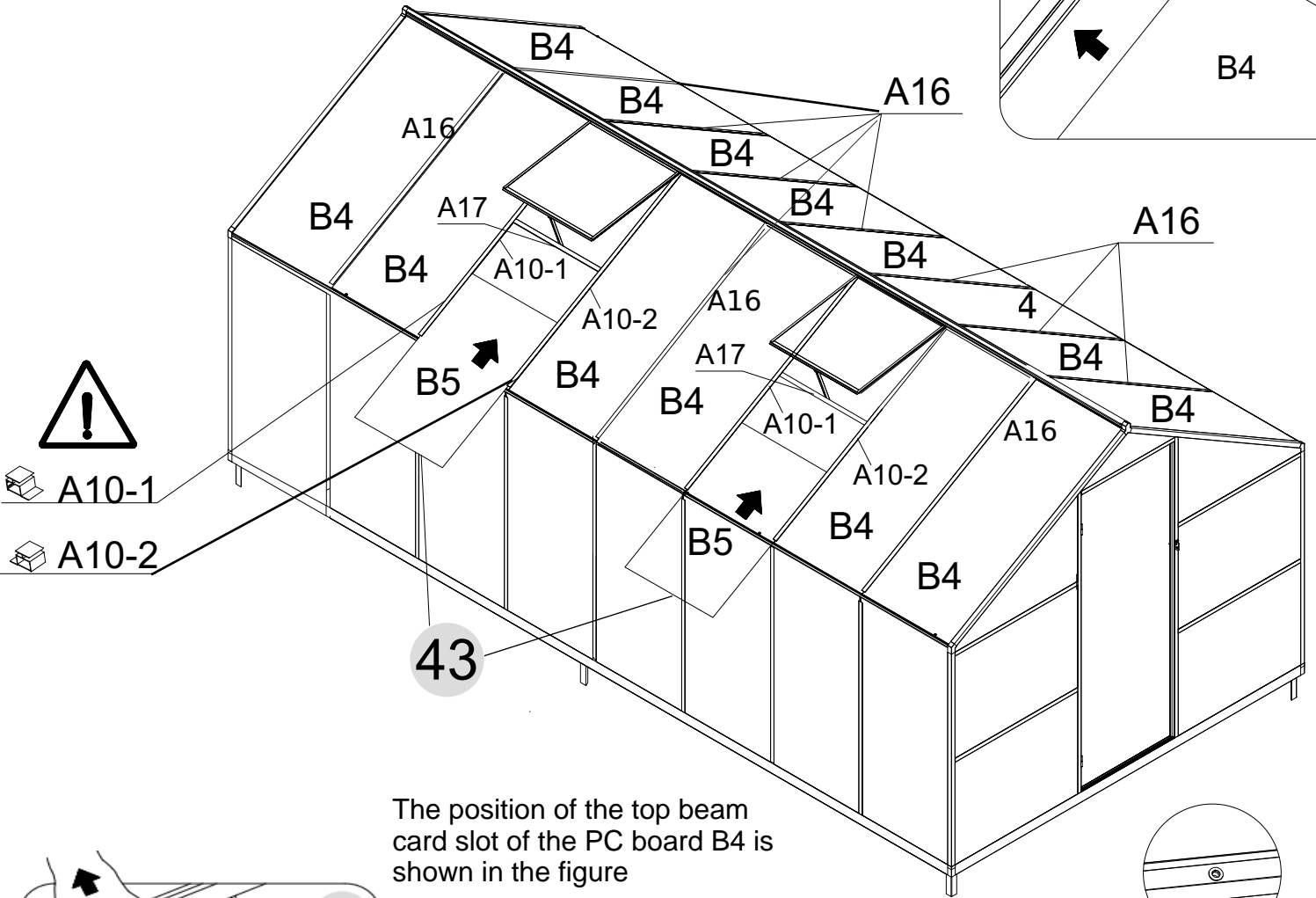
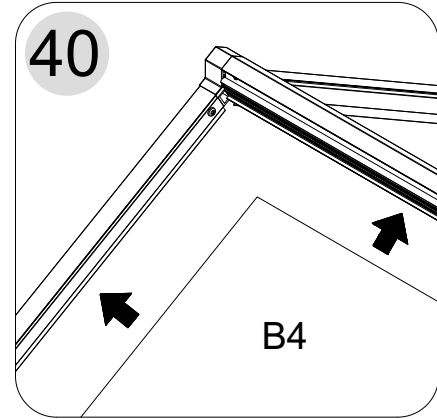
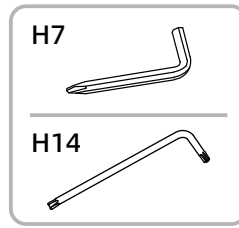

Picture	NO.	Qty.
	A10-1	x2
	A10-2	x2
	A16	x10
	A17	x2
	H8	x4

Picture	NO.	Qty.
	B4	x14
	B5	x2

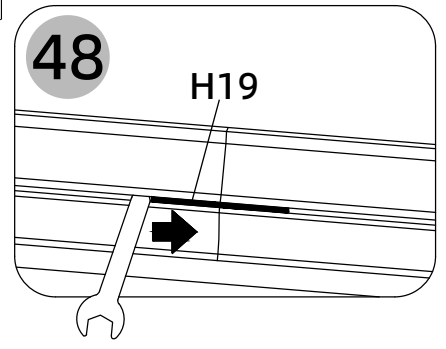
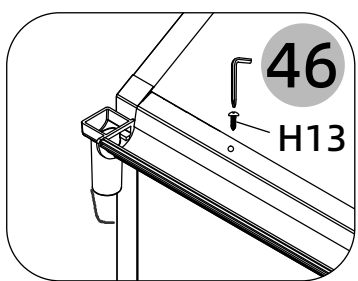
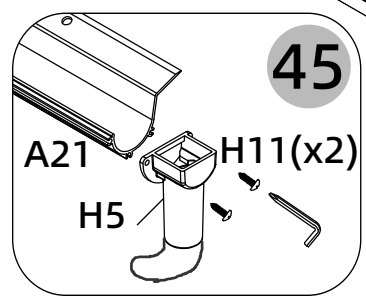
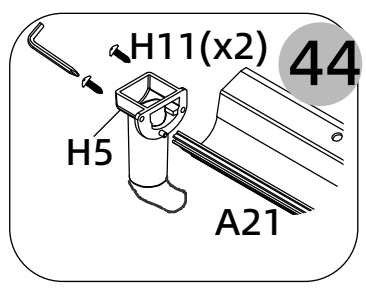
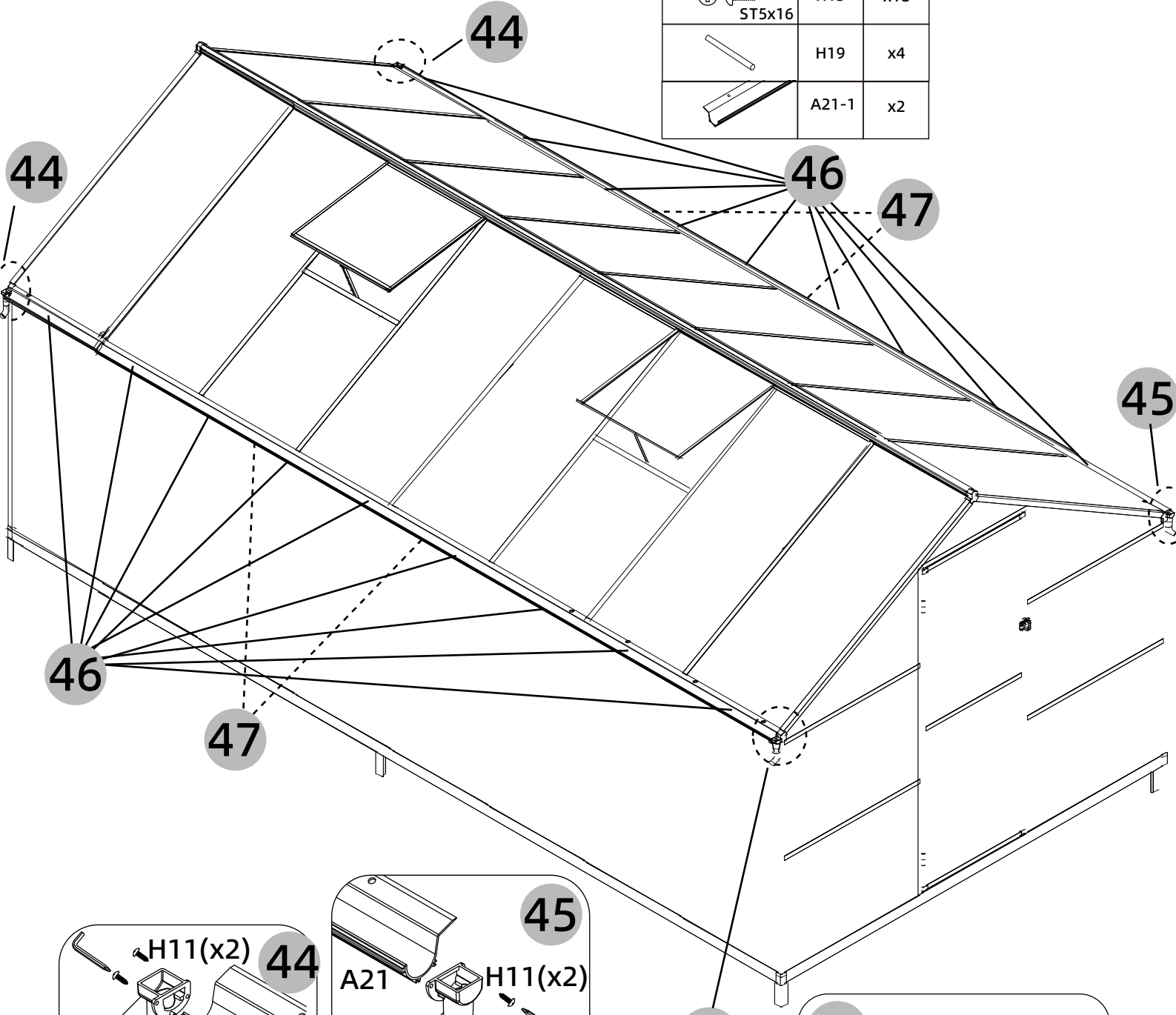
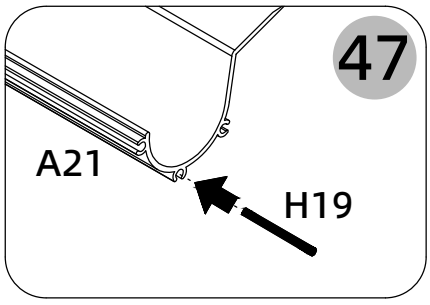
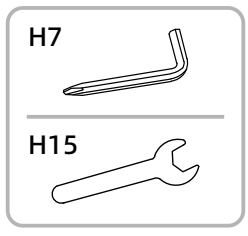

Picture	NO.	Qty.
	A21	x4
	H5	x2
	H11	x8
	H13	x18
	H19	x4
	A21-1	x2



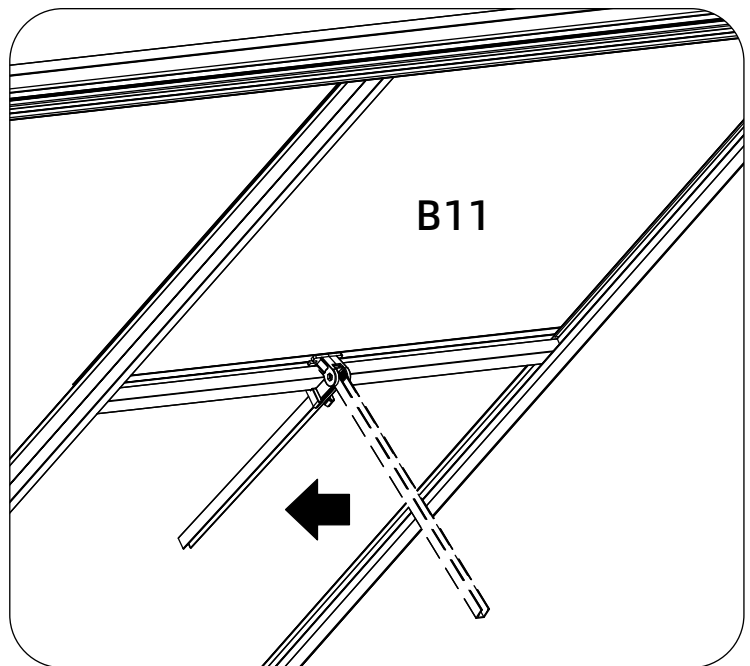
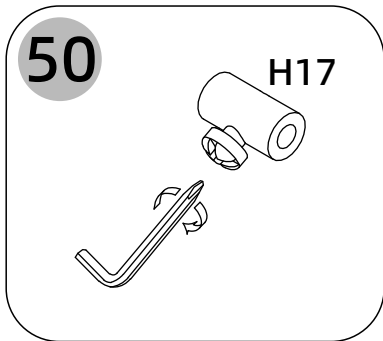
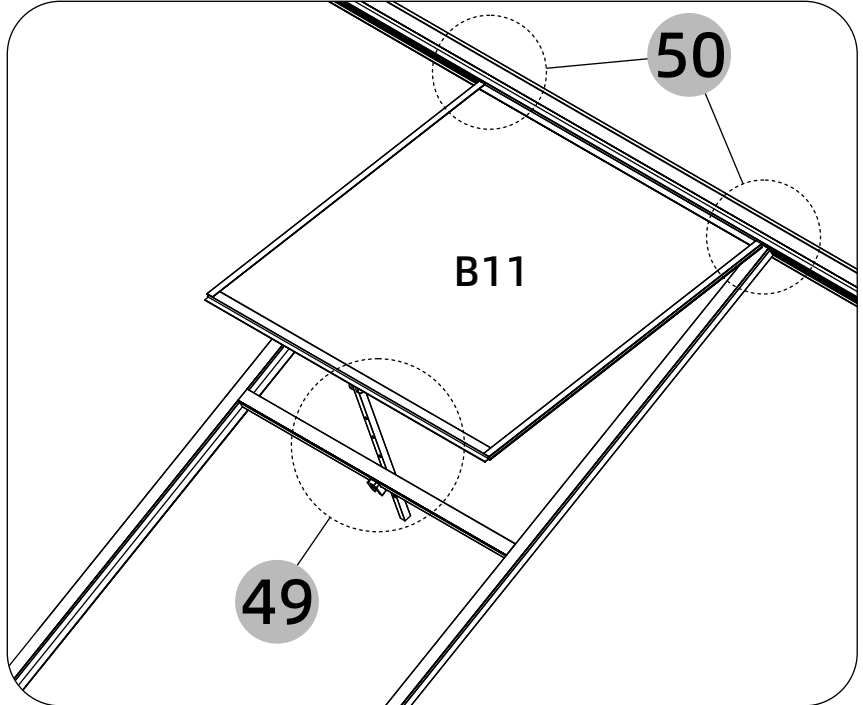
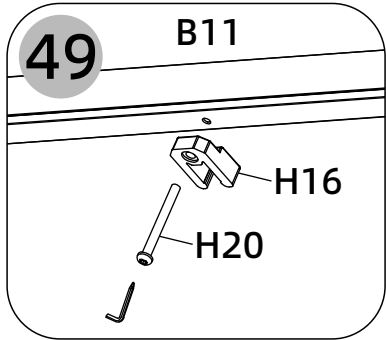
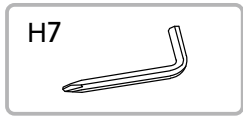

Picture	NO.	Qty.
	H16	x2
 M4x38	H20	x2

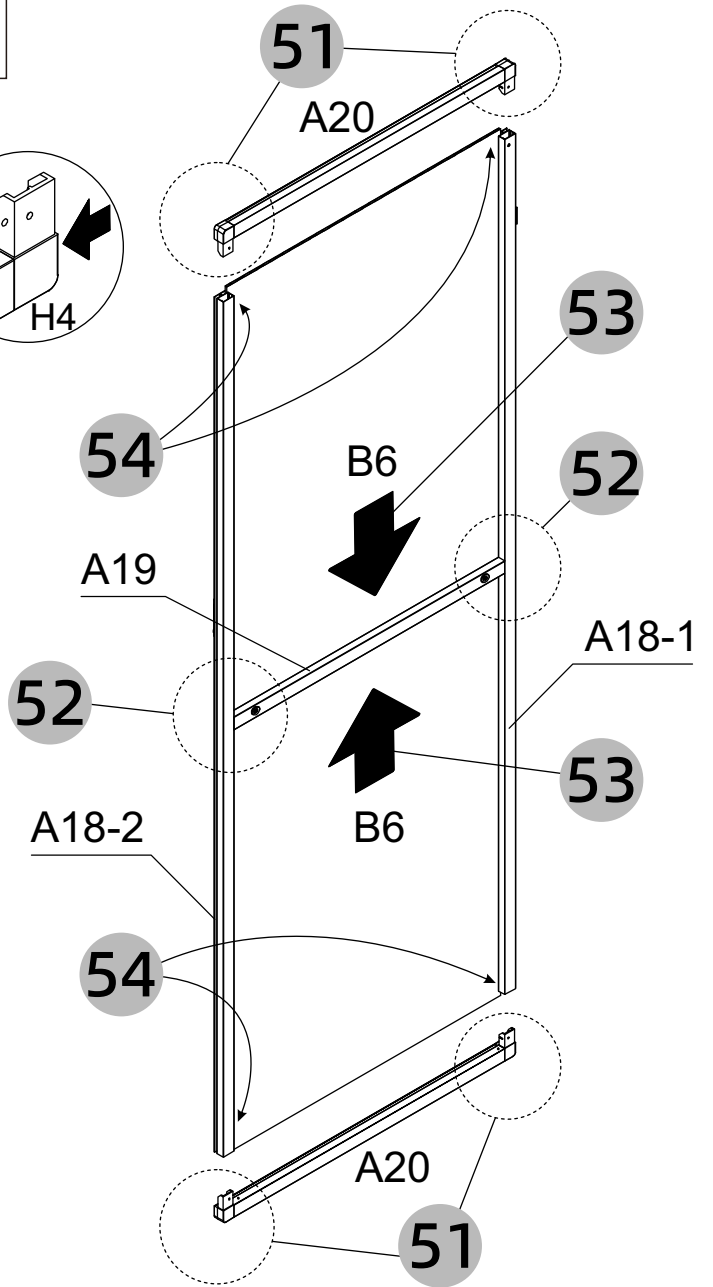
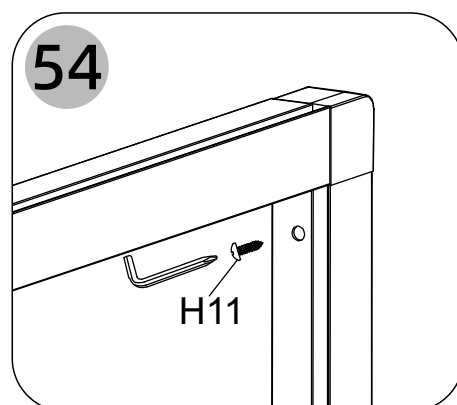
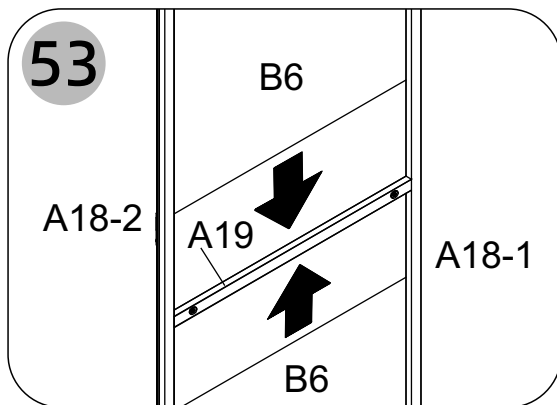
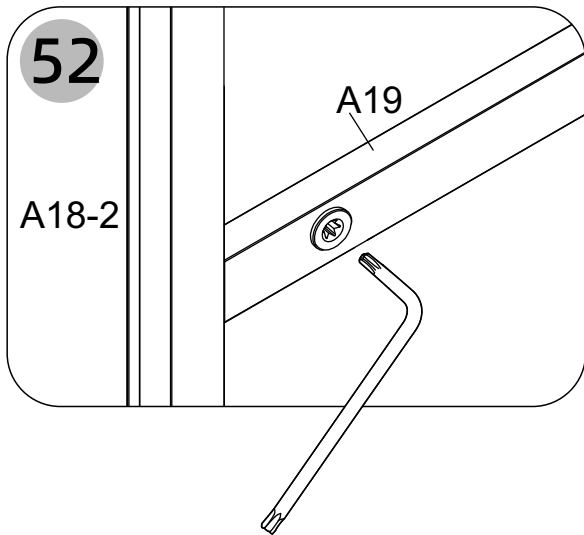
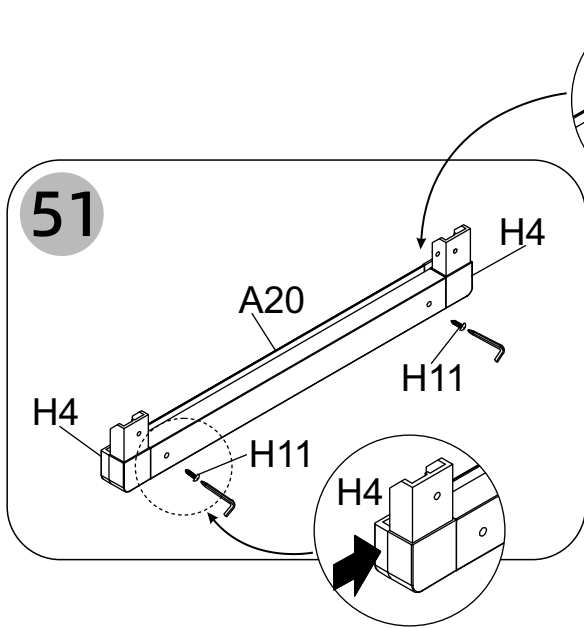
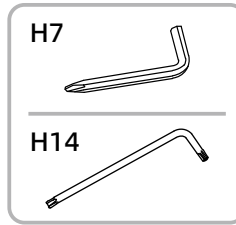

Picture	NO.	Qty.	Picture	NO.	Qty.
	A18-1	x1		H4	x2
	A18-2	x1		H11	x8
	A19	x1		ST4x10	
	A20	x2		B6	x2

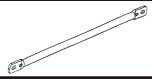

Picture	NO.	Qty.
	A23	x8
	A25-3	x4
	M6x12	x24

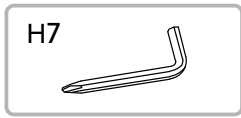

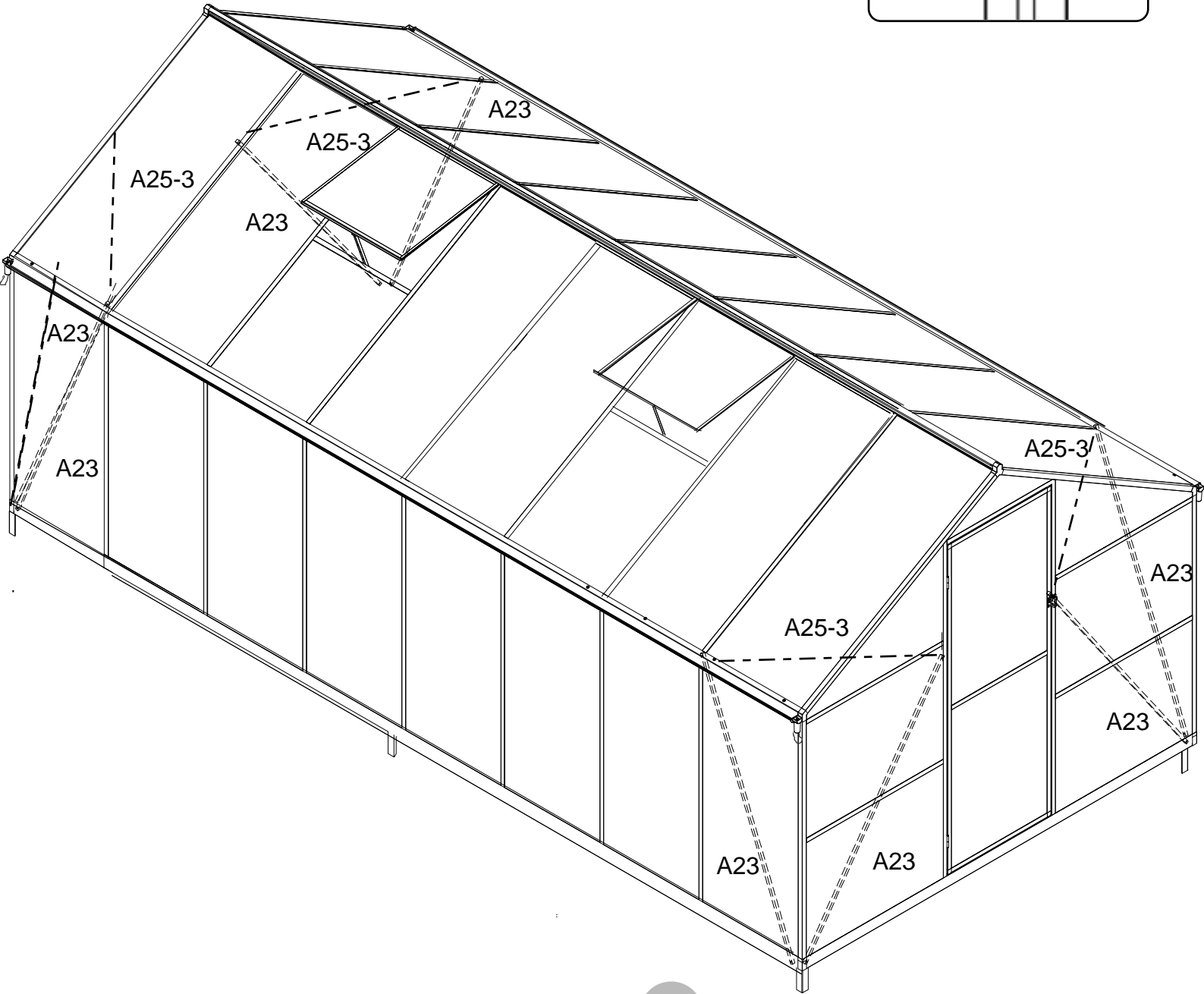
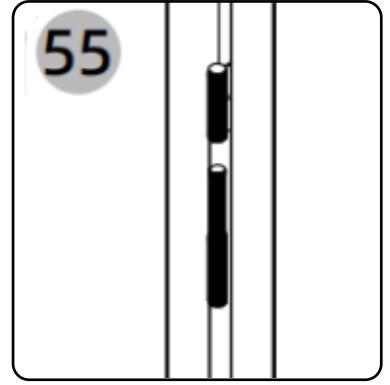

When installing the door, keep it open



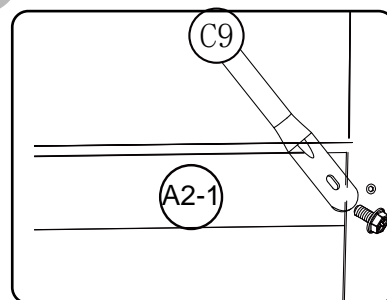
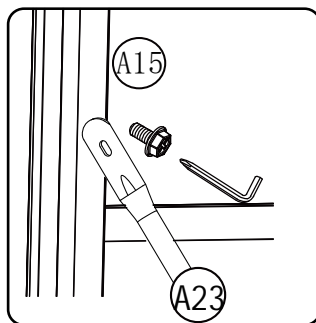

57

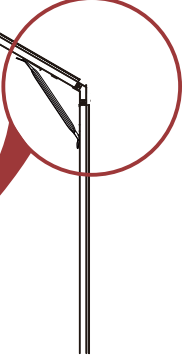
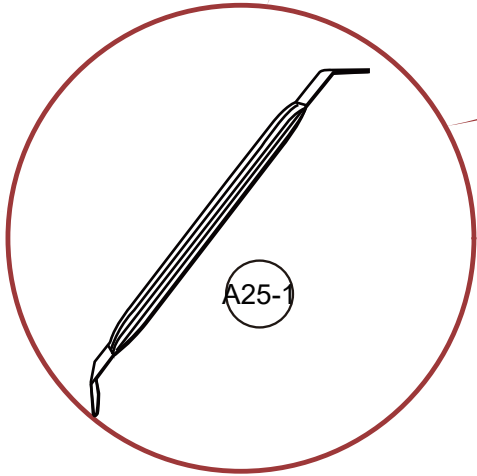
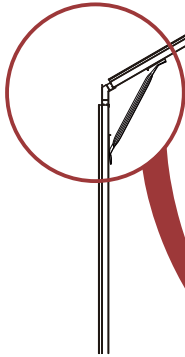
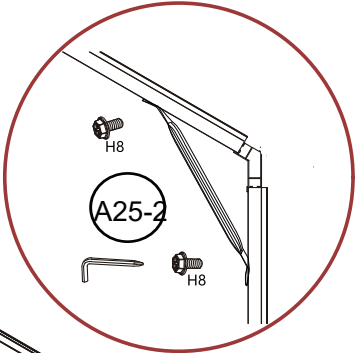
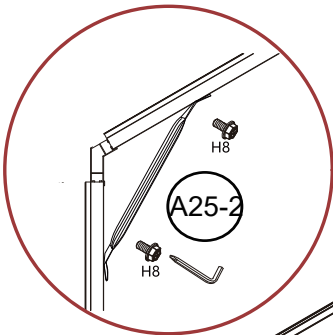
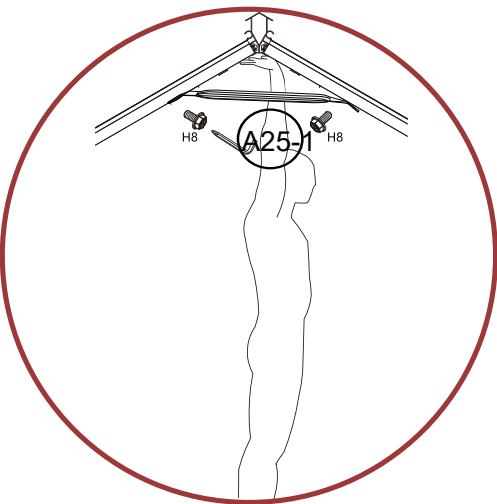

X7

Picture	NO.	Qty.
 M6x12	H8	x42
	A25-1	x7
	A25-2	x14



Picture	NO.	Qty.
	C6	x14

