

# *ASSEMBLY INSTRUCTIONS*

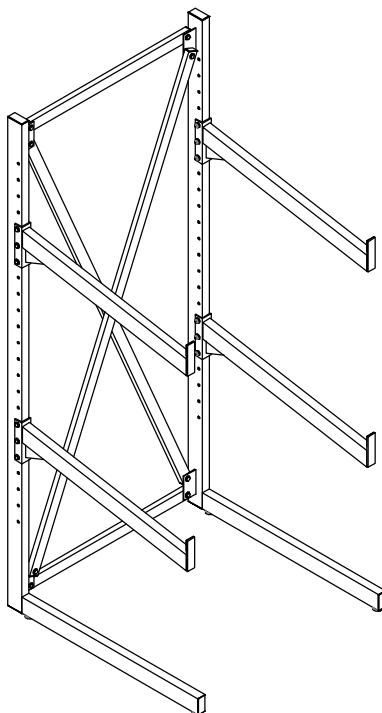

REVISION 0 : 09/06/2021  
REVISION 1 : 08/25/2023

## *SOFA BED RACK*

# ASSEMBLY INSTRUCTIONS

## ASSEMBLY TIPS:

1. Remove hardware from box and sort by size.
2. Please check to see that all hardware and parts are present prior to start of assembly.
3. Please follow attached instructions in the same sequence as numbered to assure fast & easy assembly.



## WARNING!

1. Don't attempt to repair or modify parts that are broken or defective. Please contact the store immediately.
2. This product is for home use only and not intended for commercial establishments.



ASSEMBLY TIME 50 MINUTES

## PARTS IDENTIFICATION

AN

LEFT RACK POST

1PC

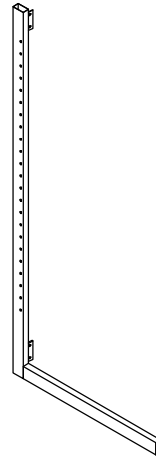

BN

RIGHT RACK POST

1PC

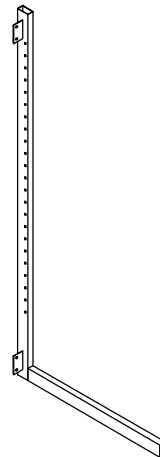

CN

SHORT RACK SUPPORT

2PCS

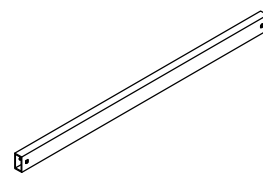

# ASSEMBLY INSTRUCTIONS

## PARTS IDENTIFICATION

DN LONG RACK SUPPORT

2PCS

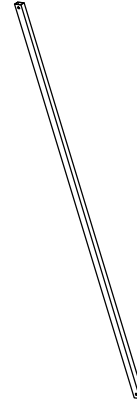

EN RACK ARM

4PCS

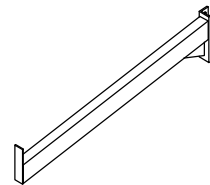

ZN

## HARDWARE IDENTIFICATION

1 SHORT HEX BOLT  
(3/8" x 45mm BLK)



8PCS

2 LONG HEX BOLT  
(3/8" x 65mm BLK)



12PCS

3 FLAT WASHER  
(3/8" x 25mm BLK)



40PCS

4 HEX NUT  
(3/8" BLK)



20PCS

5 STICKER  
(60 x 40mm)

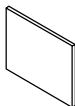

4PCS

6 LEG PAD  
(3/8" x 32mm)



4PCS

7 SMALL CAP  
(25 x 50mm BLK)



8PCS

8 LARGE CAP  
(40 x 80mm BLK)

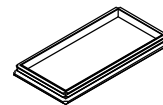

6PCS

9 WRENCH



2PCS

# ASSEMBLY INSTRUCTIONS

**STEP 1** Do not tighten until each step is completed or instructed.

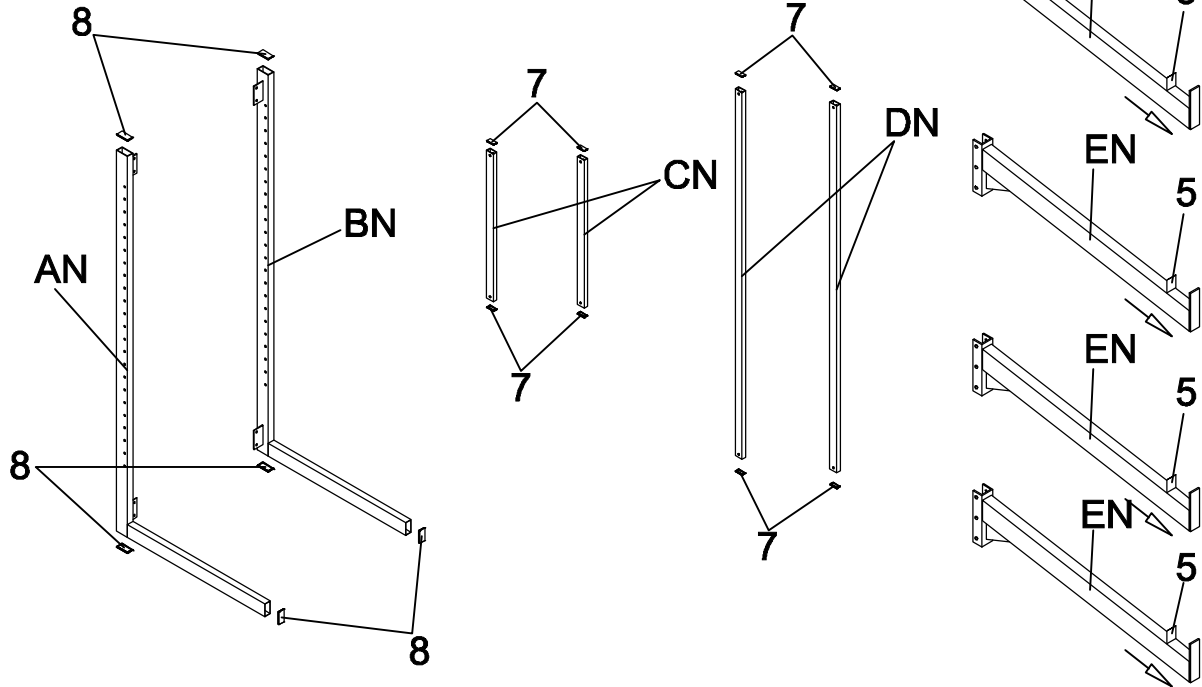

## STEP 2

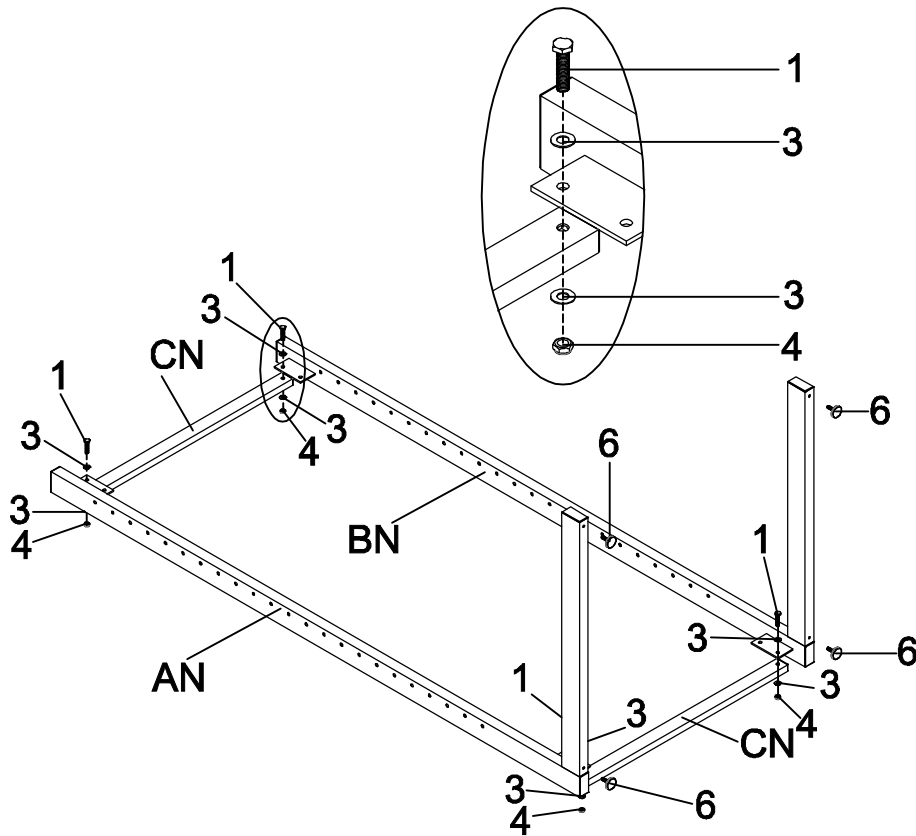

# ASSEMBLY INSTRUCTIONS

## STEP 3

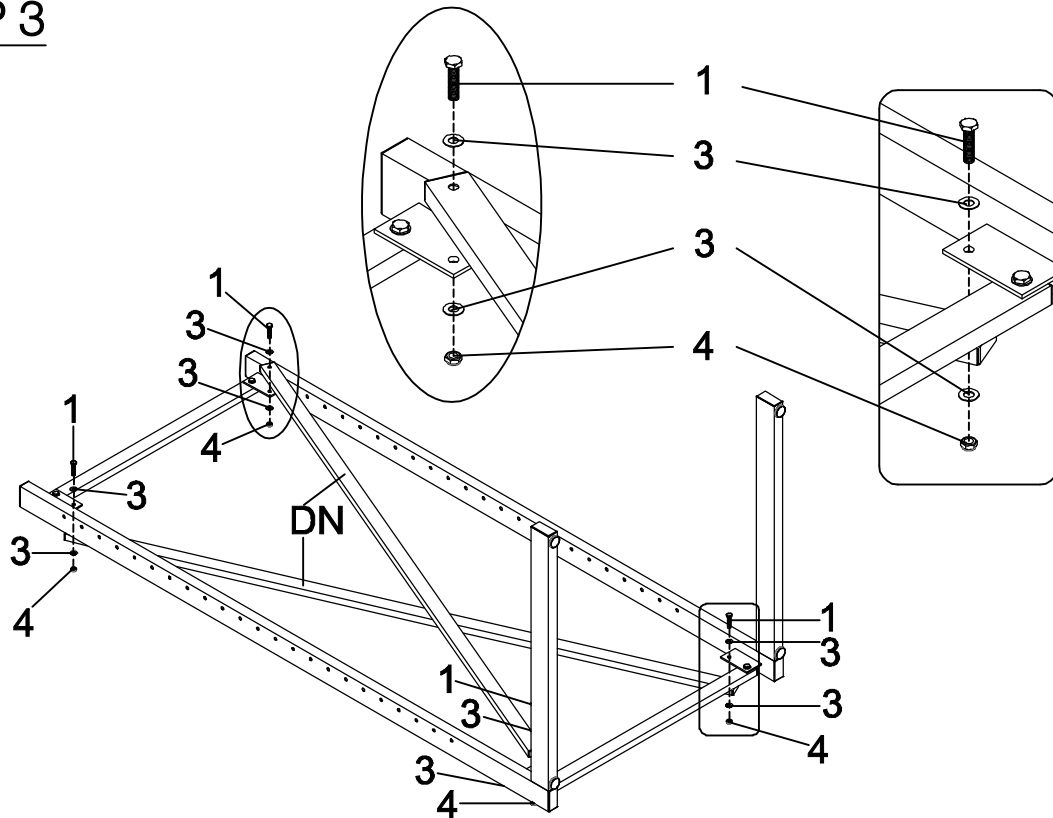

## STEP 4

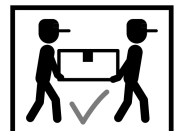
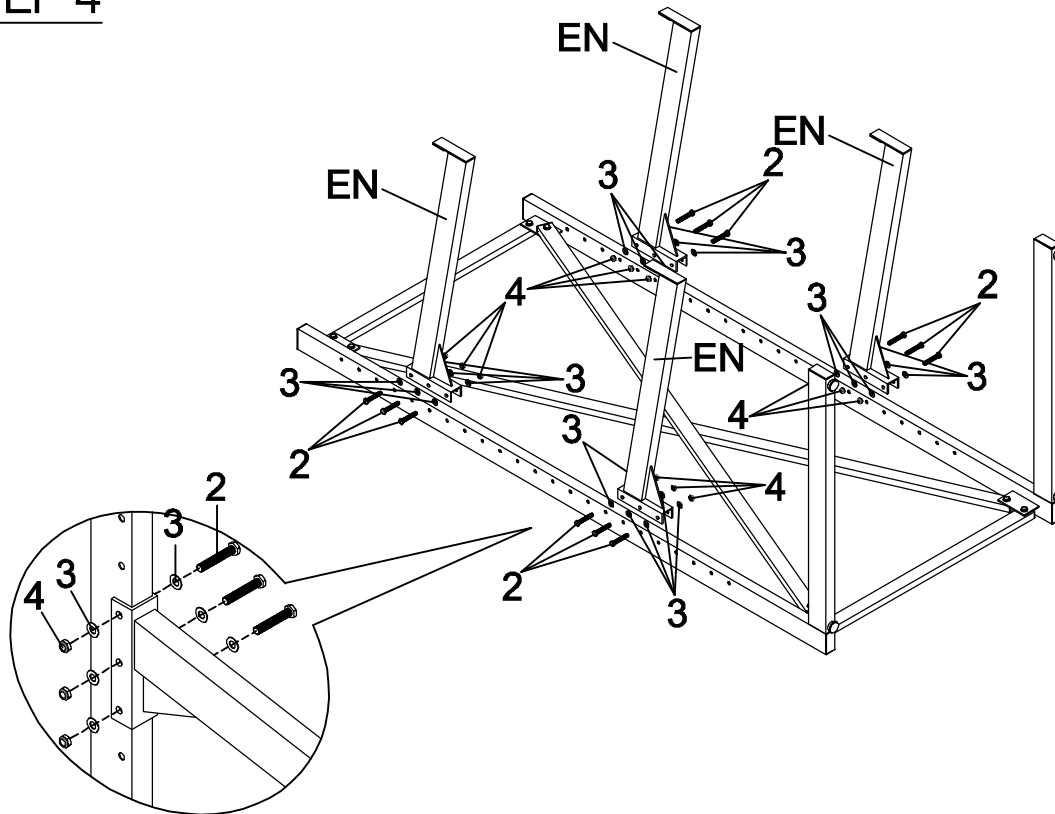

# ASSEMBLY INSTRUCTIONS

Product Size : 1086 X 1073 X 2426 H (MM)
Product Size : 42.75" X 42.25" X 95.5"

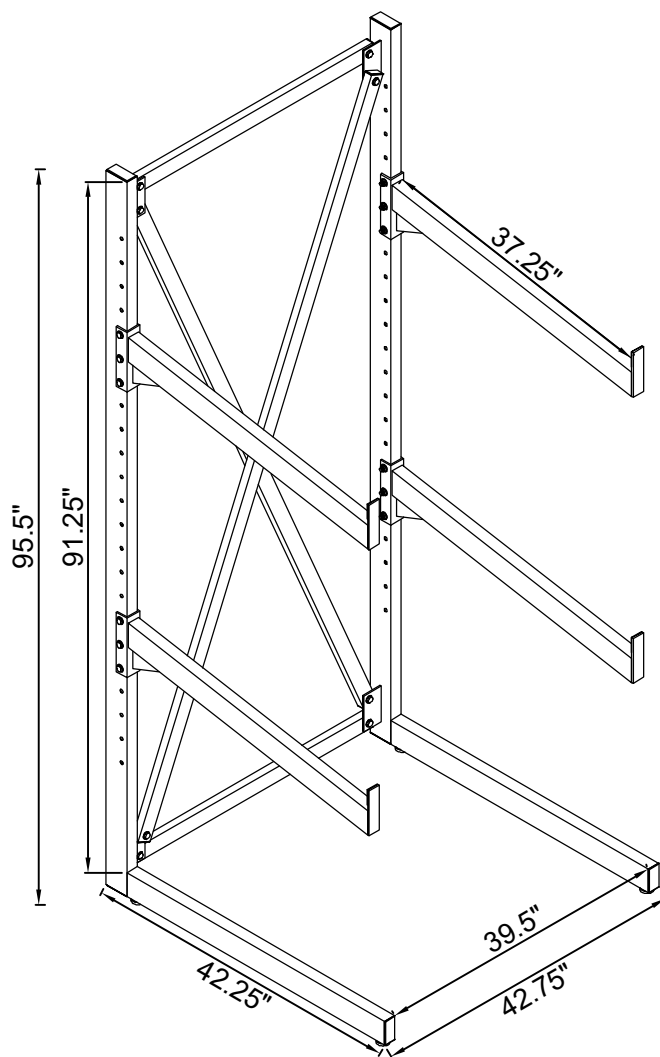

Note : Dimension tolerance  $\pm 5\%$