

Owner Manual

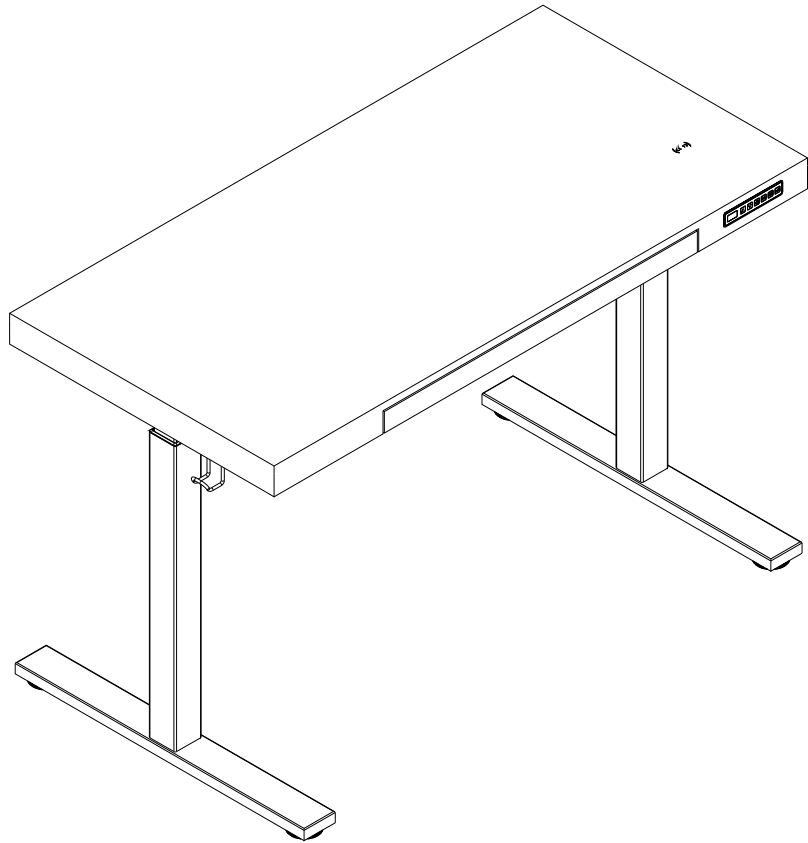

Standing Desk

Specifications

Max. Weight Capacity	110 lbs (50kg)
Speed	25mm/s
Input Voltage	120 V
Min. Height	28.9" (735mm)
Max. Height	47.2" (1200mm)
Duty Cycle	10% (Working 2 minutes then stop 18 minutes)
Certification	FCC

Accessory Package

PLEASE NOTE: Check that you have received all components and hardware before assembling. If you are missing any parts, please contact us for replacement parts.

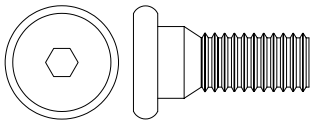

A. 3/4" Medium Machine Screw - 8

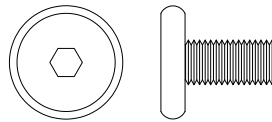

B. 1/2" Small Machine Screw - 8

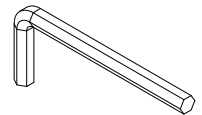

C. Wrench - 1

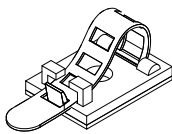

D. Self-adhesive Cable Strap - 2

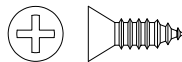

E. 1/2" Wood Screw - 2

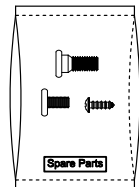

F. Spare Parts - 1

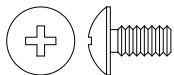

G. 5/16" Machine Screw - 4

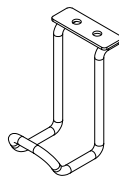

H. Ganchos - 2

Diagram of Components



STEP 1

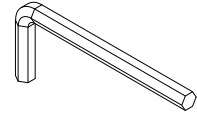
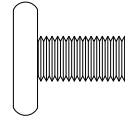
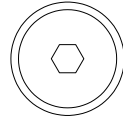
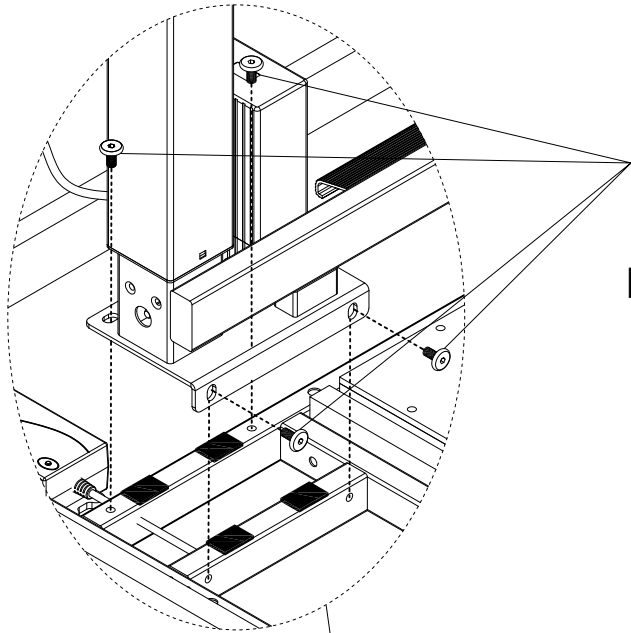

B. 1/2" Small Machine Screw - 8

C. Wrench - 1

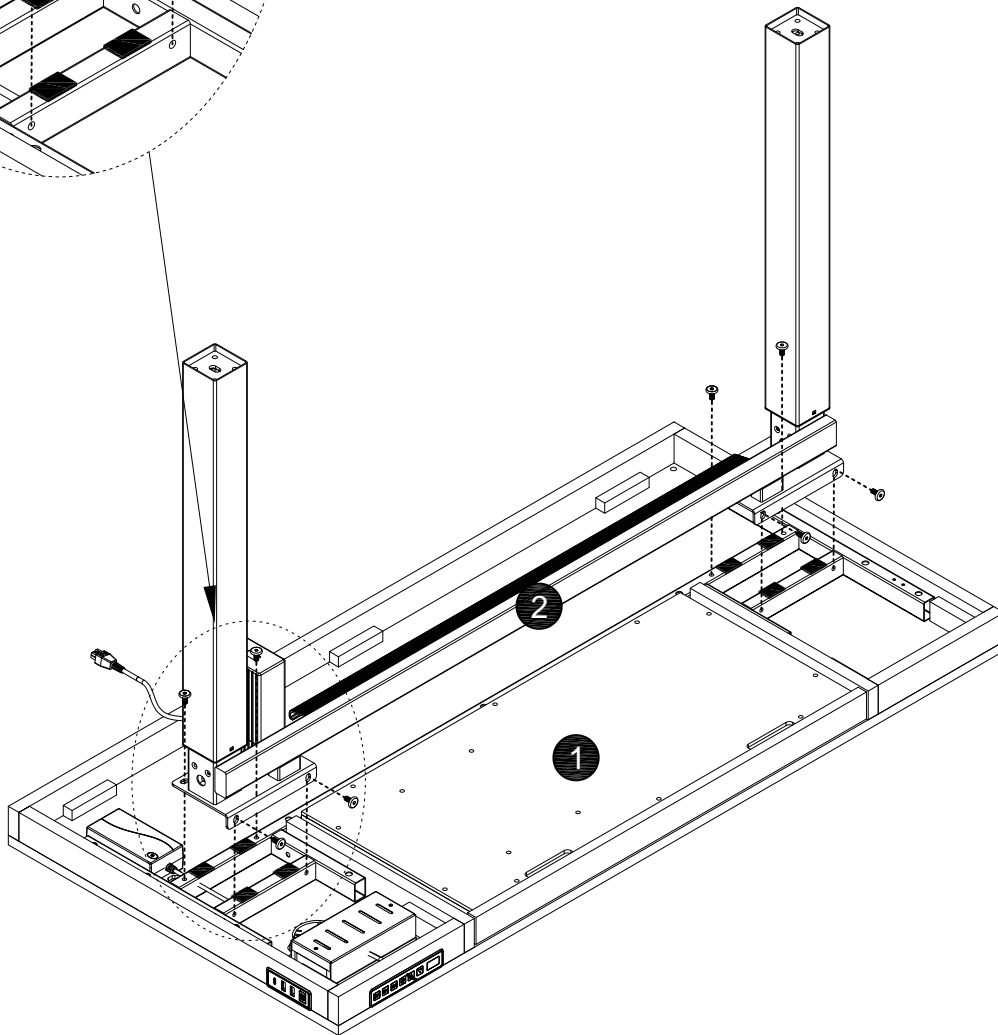

STEP 2

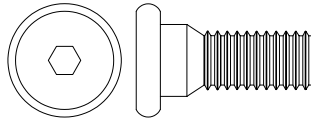
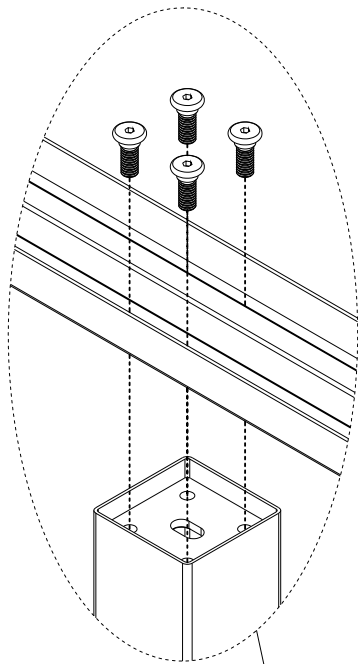

A. 3/4" Medium Machine Screw - 8

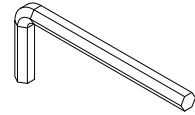

C. Wrench - 1

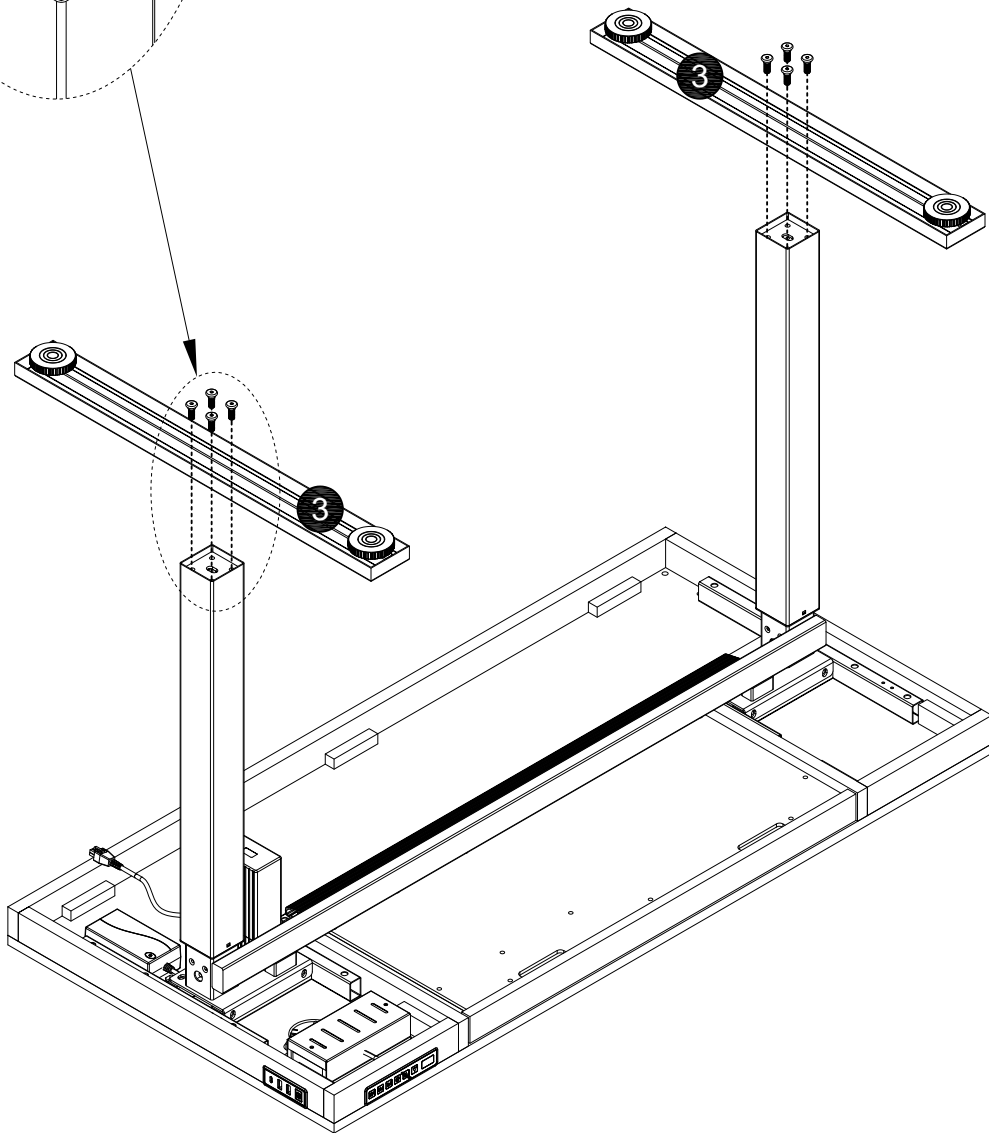

STEP 3

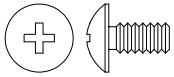

G. 5/16" Machine Screw - 4

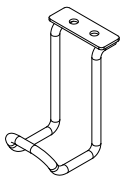

H. Ganchos - 2

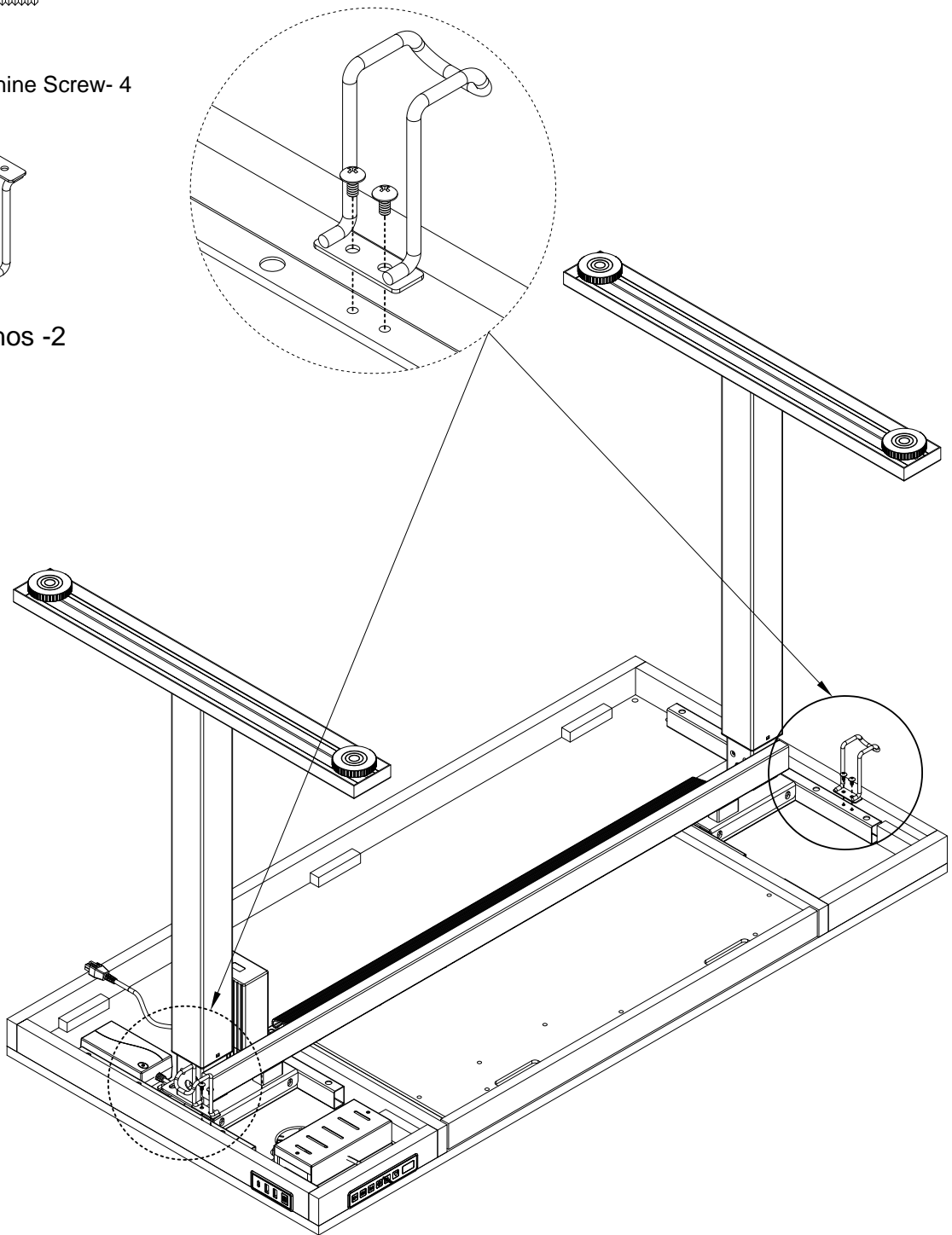

STEP 4

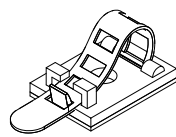
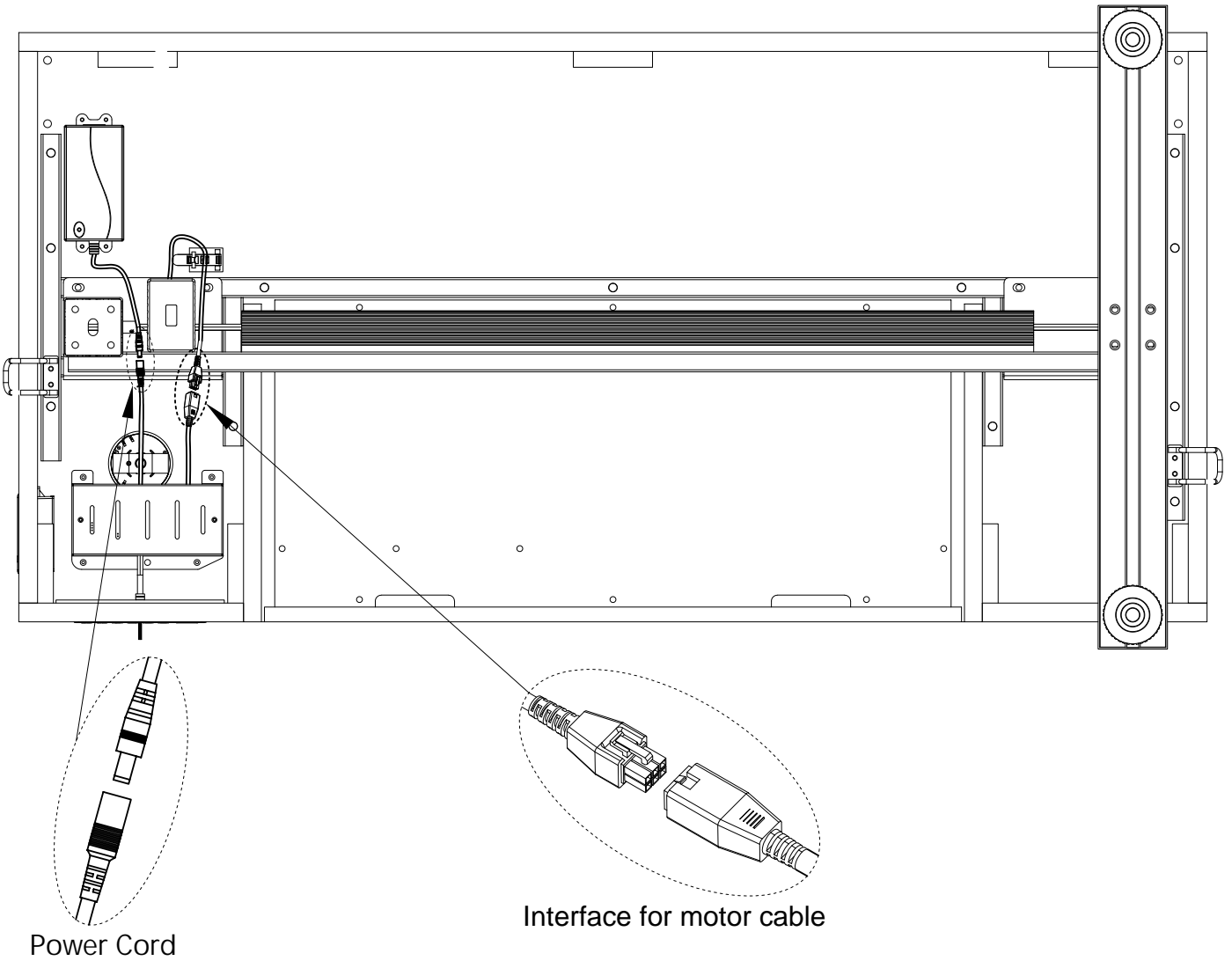
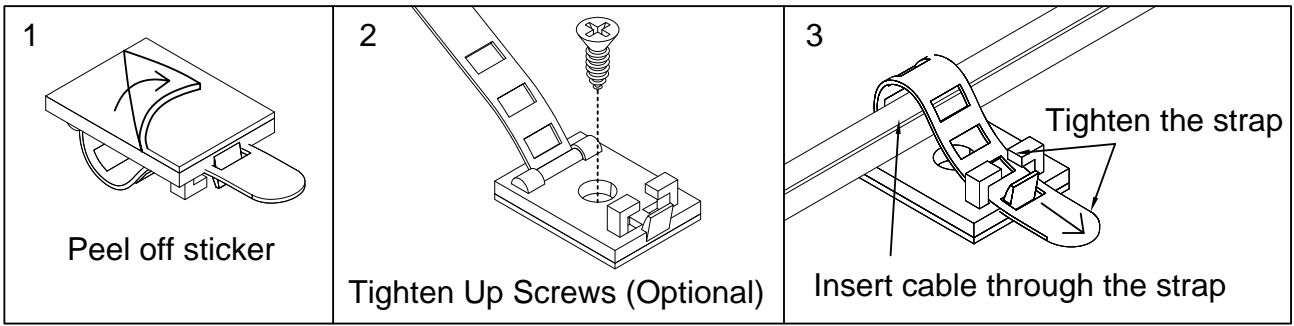

D. Self-adhesive Cable Strap - 2

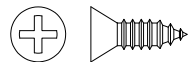

E. 1/2" Wood Screw - 2

STEP 5

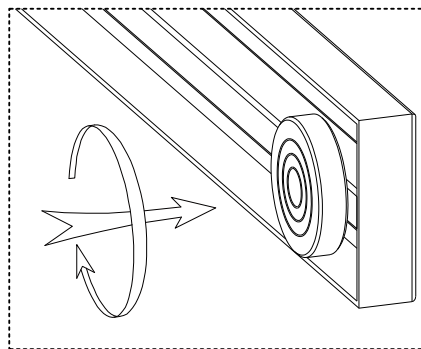
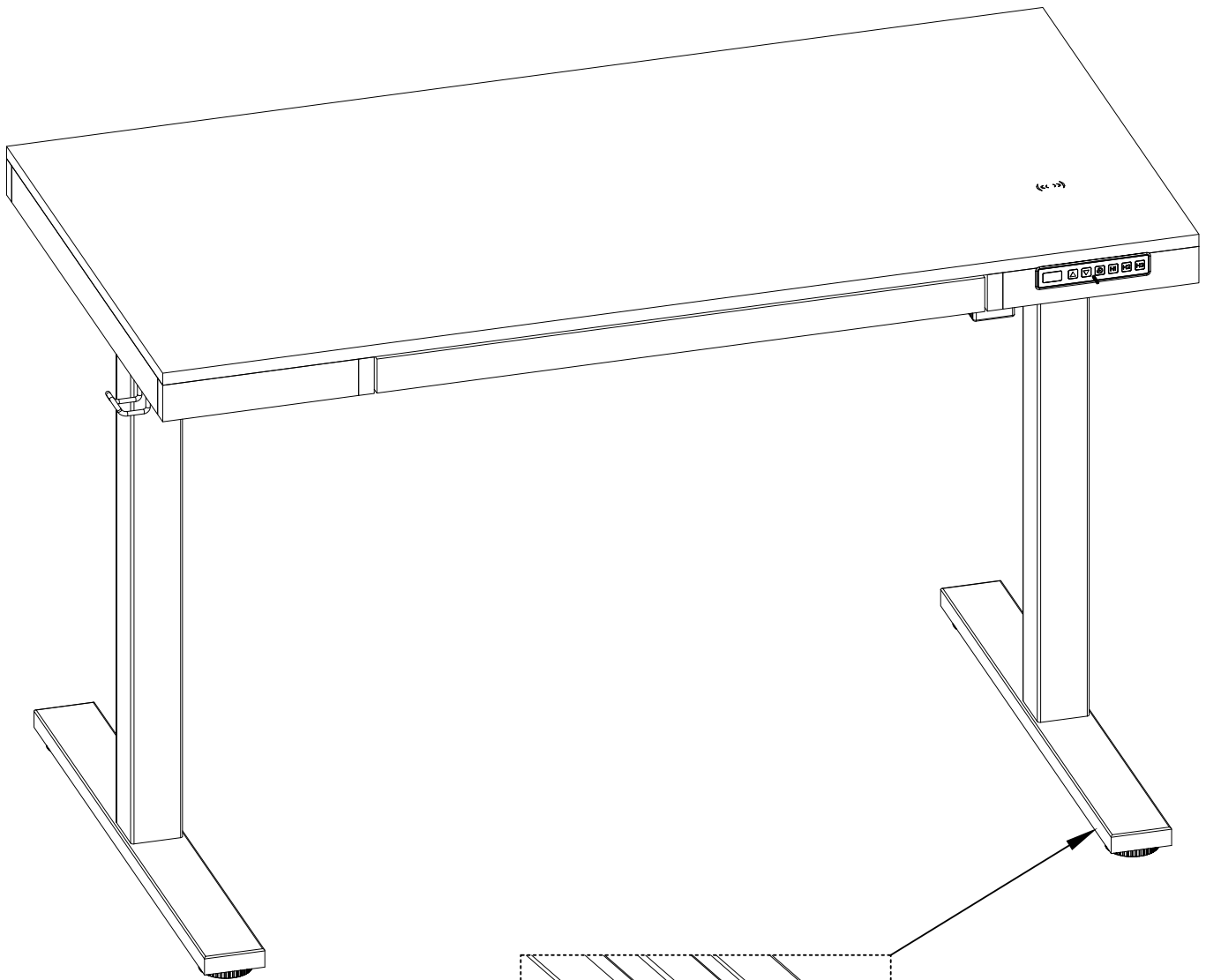

Leveling foot adjustment

STEP 6

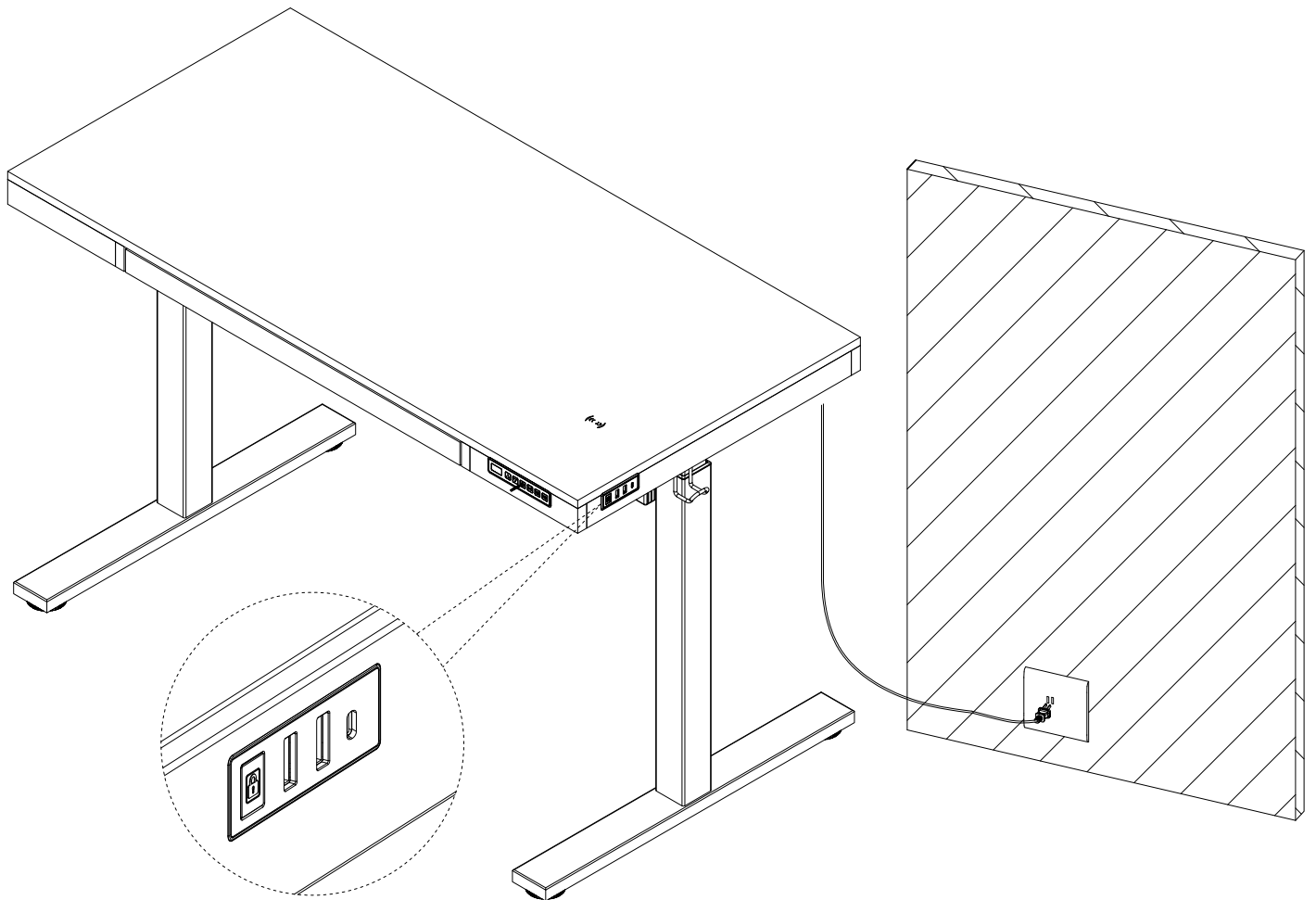

Factory reset is required for first time initialization(Page 11)

OPERATION

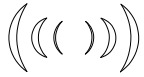
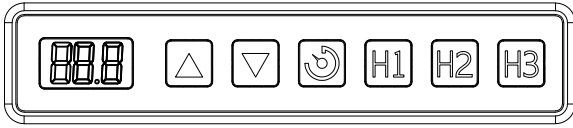

----- Wireless Charger
5W /7.5W /10W

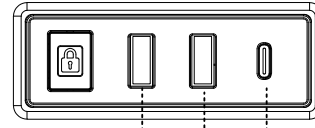

3 USB Ports

(2 Type A 5V2.4A, 1 Type C 20V2.25A)

While adjusting the height of your desk, your USB port will pause charging until the process completes.

Control Panel

-Lock Button" ":

NOTE: It is strongly recommended to use this feature to avoid any unexpected/unintentional movement.

1. Press this button to lock the touch-screen. This will prevent accidentally engaging the controls after the desired height has been set. Press the button again to unlock the touch-screen.
2. To change between inches and centimeters, press and hold the Lock button for 5 seconds.

-Display:

1. The display will indicate the height of the desk (inches) . After five seconds without input, the digital readout will automatically fade away.
2. When the desk has reached the lowest setting, the display will indicate "bot".
3. When the desk has reached the highest setting, the display will indicate "top".
4. Touch and hold one of the memory buttons (H1-H3) for 3 seconds when the desk is at the desired height in order to save it as a memory preset. The desk will automatically return to the set height when the corresponding memory button is touched.
5. Touch and hold the ▼ button to lower the desk and release when it arrives at the desired height. The desk is at the lowest height setting when "bot" is displayed.
6. Touch and hold the ▲ button to raise the desk and release when it arrives at the desired height. The desk is at the highest height setting when "top" is displayed.

-Timer Button" ":

The time is displayed in minutes and the point will not appear. For example, the readout will display 105 or 90, as opposed to 10.5 or 9.0.

1. Touching the timer button will cause the digital readout to blink. Use the Up button ▲ to cycle through the timer settings: 00, 10, 15, 30, 45, 60, 75, 90, 105, 120. Use the Down button ▼ to cycle through the timer settings: 120, 105, 90, 75, 60, 45, 30, 15, 10, 00. Touch the timer button again to confirm and start the countdown.
2. When the timer function is activated, the digital readout will display the timer in descending minutes. For example, 120, 119, 118, 117.....05, 04, 03, 02, 01, 00). At that time, if the desk's height is adjusted, the readout will show the height and return to the timer afterwards.
3. When the countdown is finished, the desk will beep 5 times continuously in 3 total successions and remain stationary.

TROUBLE SHOOTING

PROBLEM	ROOT CAUSE	CORRECTIVE ACTION
Display indicates E1	The motor has overheated.	Unplug the power cord and re-plug after 18 minutes.
Display indicates E2	The top load is too heavy.	Reduce the top load to a maximum of 45.4 kg (100 lbs).
	The motor is stuck.	Visually inspect whether there are any foreign materials or objects obstructing the motor and/or its shaft. Unplug the power cord for 5 minutes and then plug in again.
Display indicates E3	The motor is not powered.	Unplug the unit and visually inspect whether there are any loose electrical connections between the power cord and the adaptor, or from the adaptor to the motor. Unplug the power cord for 5 minutes and then plug in again.
Display indicates E4	Motor voltage is too low.	Ensure that the power adapter is the same as supplied with the desk according to the specifications described on page 4. Unplug the power cord for 5 minutes and then plug in again.
Display indicates RES	Desk needs to be reset to accurately display height.	A factory reset is required for the first initialization or when power is cut off due to electrical problems. Make sure that the cables are all connected before powering up. Press and hold the "▲" and "H3" for 5 seconds after connecting to power until the RES shows on screen. The table automatically goes down until it reaches the bottom and bounce back slightly with a "beeping" sound. The "bot" message will then display on the screen. The reset process is complete.
Display indicates E12	There has been a motor failure.	Contact customer service.

Attention

- Power supply: AC100V-240V~, frequency 50/60HZ;
- Working environment: 32° - 104° F ;
- Before cleaning, you have to unplug the power supply cable. Clean with a slightly damp cloth to wipe away the surface dust. Keep all electrical components away from liquids. Do not damage the connection line and keep the plug in a safe position.
- Inside the control box, there are electronic components, metal parts, plastic parts, wires and so on. They should be disposed in accordance with the local laws and regulations. They cannot be disposed as household waste.
- Before using the product, please make sure the product has been installed correctly.
- Before starting use of the product, please read the instructions to fully understand all the product's functions and settings.
- Keep children away from electric height-adjustable desks, control units and handsets. Manufacturer is not responsible of any damages that result from children's unpredictable behaviour.
- Slight noise caused by the multi wedge belt or brake system will not impact the use of this product.
- Do not use corrosive or abrasive materials to clean this product and please dispose of cleaning solutions in an environmentally friendly manner.
- Understand the risks associated with using this product. Children or those with cognitive impairment should not use this product without supervision.
- If the power supply cord is damaged or broken, it must be replaced by the manufacturer or a relevant specialist to avoid any injuries.
- Please operate in a clean and safe environment. For example, do not left around your tools. And always be careful to deal with packaging materials, in order to avoid any kinds of possible danger. Potential choking risk exists when children play with plastic bags!
- If necessary, retain the original package for future transportation.

Recycling and Disposal



This product cannot be disposed of as household waste. To prevent damage to the environment, this product should be recycled. Please use the relevant recycling systems available to you or contact the distributor or manufacturer for recycling assistance.