

WF280856

SPECIAL TIPS FOR FITTING CAM-LOCKS AND QUICKFIT

CAM-LOCK

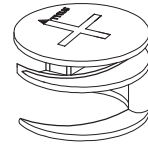

WHEN FITTING CAMLOCK
ENSURE STARTING POSITION IS CORRECT
BEFORE YOU INSERT CONNECTING QUICKFIT
TURN CLOCKWISE UNTIL SECURE

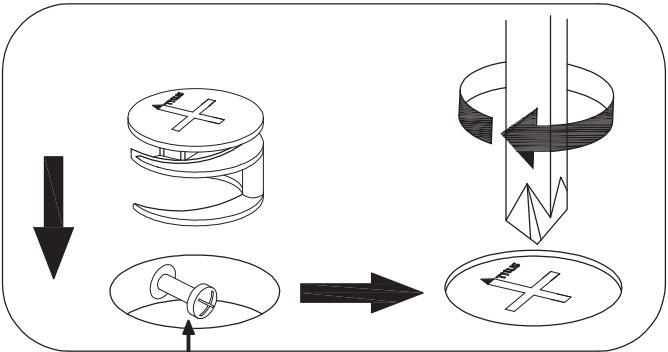
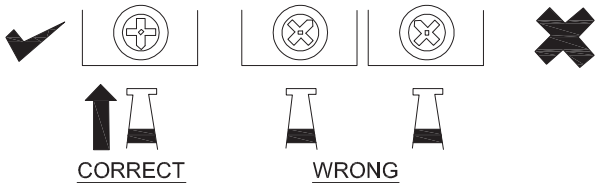

Quickfit head needs to be in centre

DRAWER CAM-LOCK

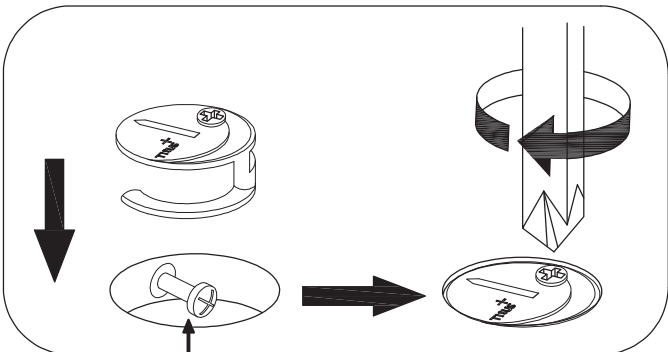

Quickfit head needs to be in centre

QUICKFIT

Tighten until shoulder is flush with panel. Do not overtighten or undertighten (see example below)

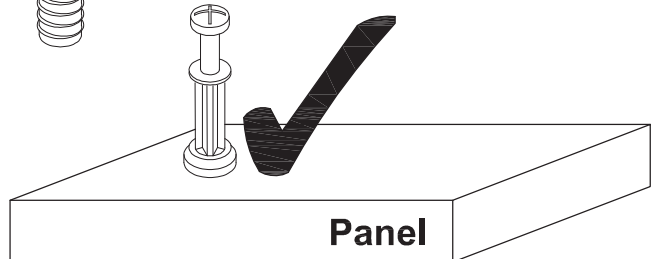
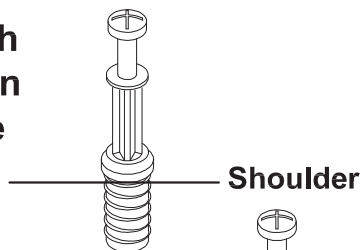
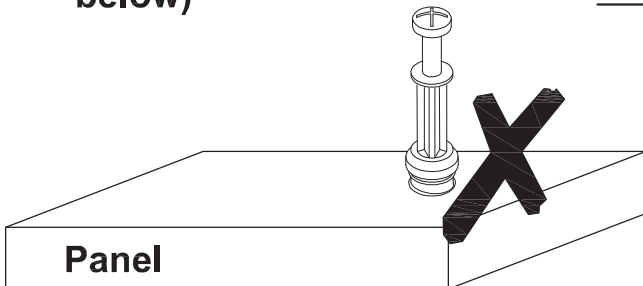

Notes

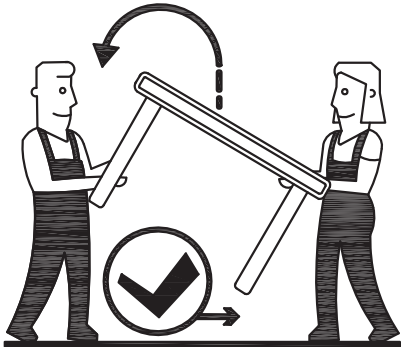
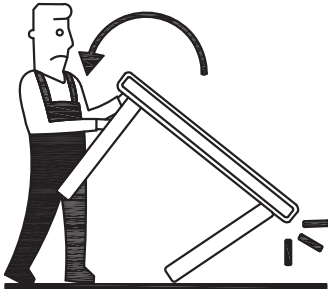
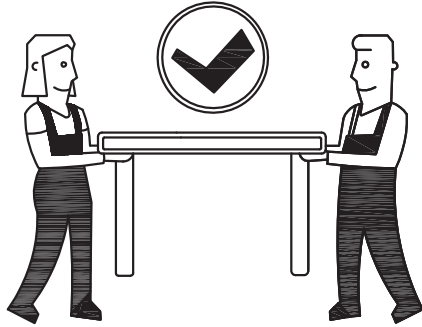
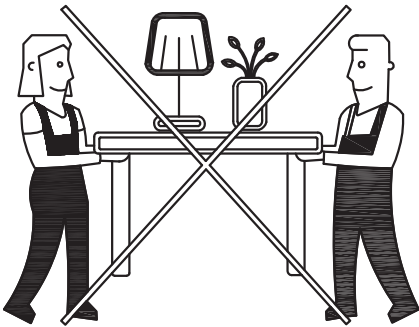
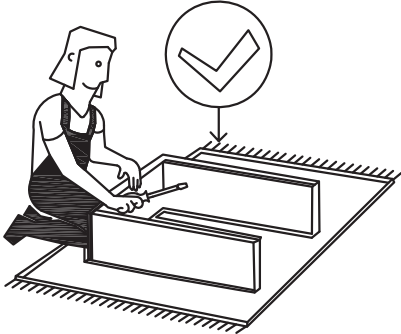
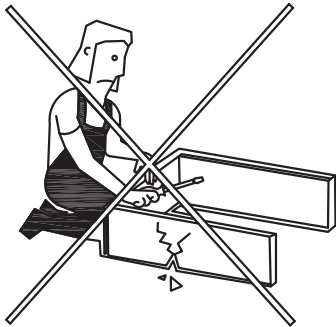







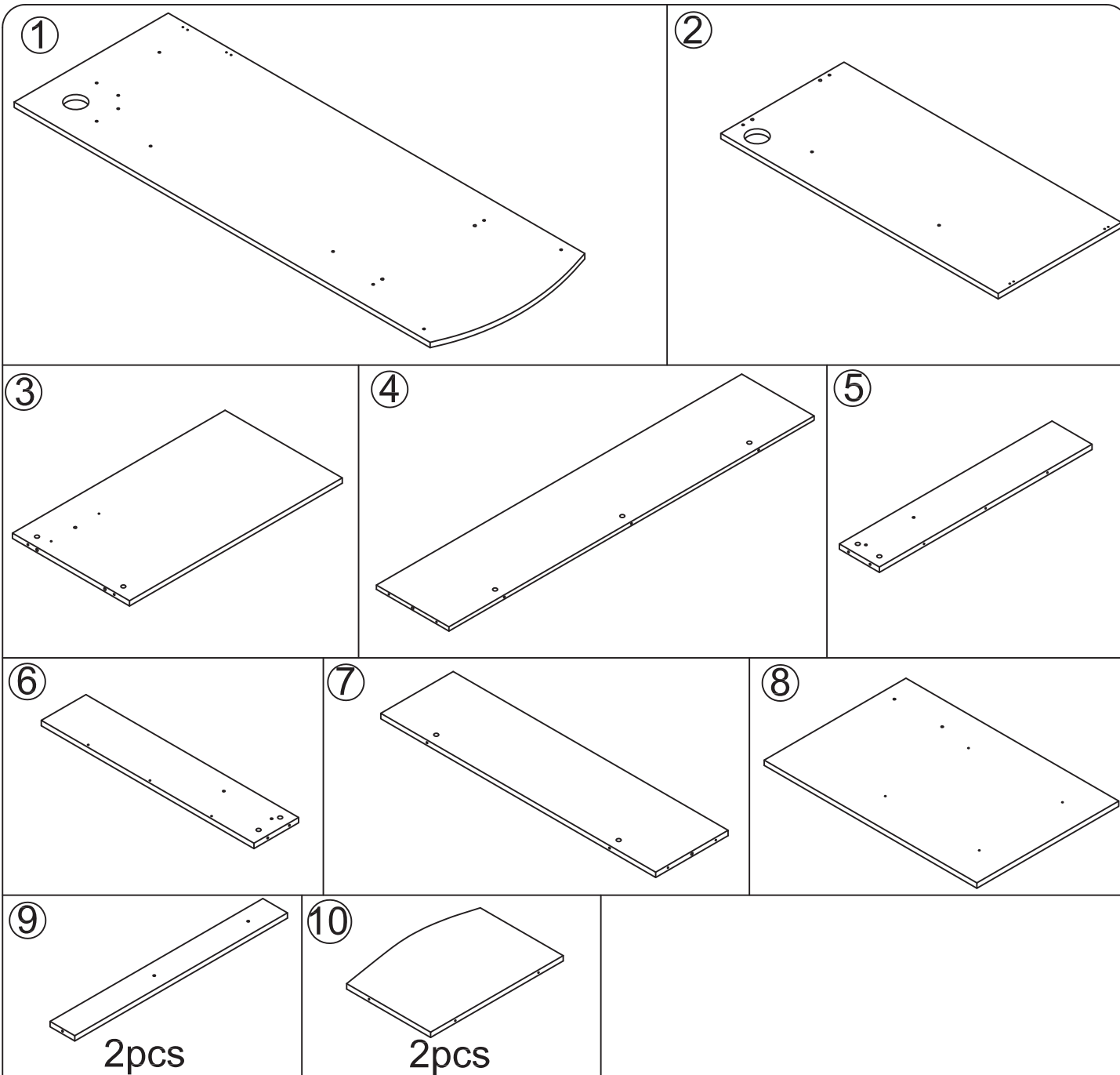



WF280856

P.2





| | | | |
|---|-------|----|--|
| A | M6x35 | 15 |  |
| B | | 15 |  |
| C | M6x30 | 8 |  |
| D | M4x14 | 8 |  |
| E | | 2 |  |
| F | | 1 |  |
| G | M5x50 | 19 |  |
| H | | 2 |  |

1

.Hardwares

A  M6X35
15 PCS

E  2 PCS

D  M4X14
4 PCS

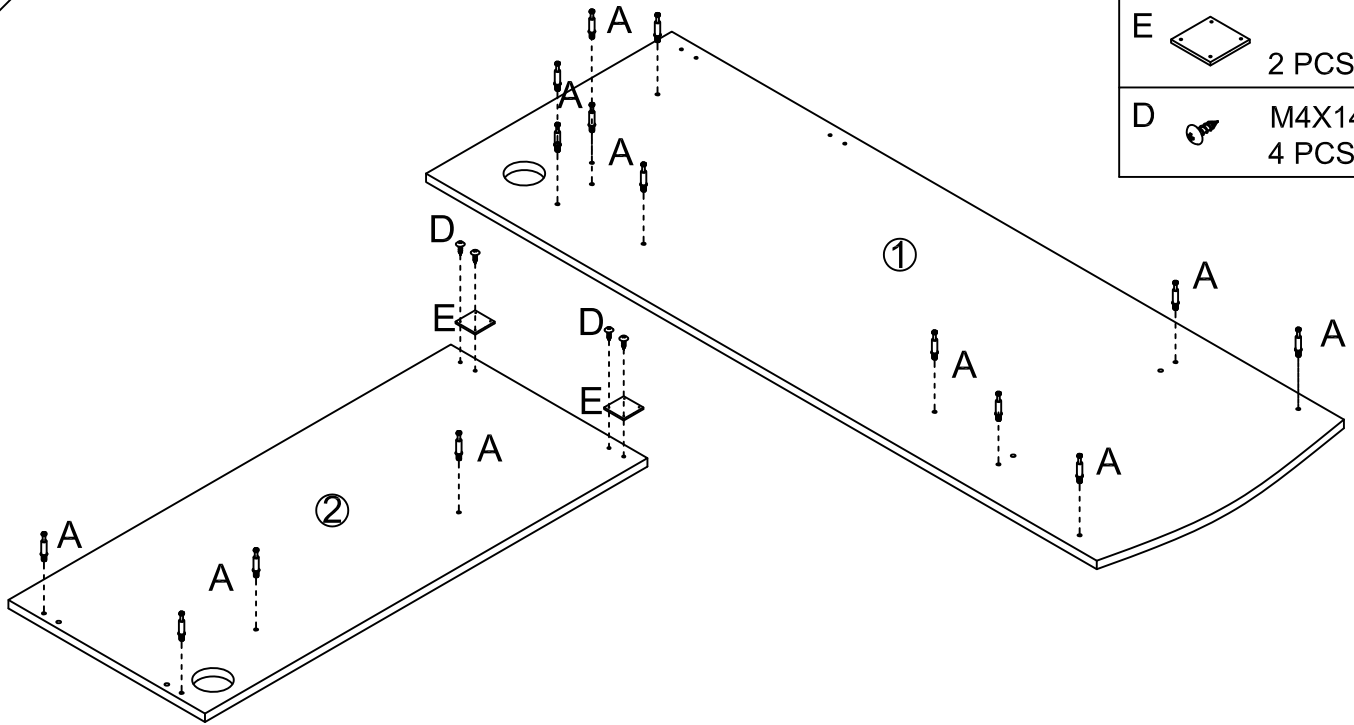

2

.Hardwares

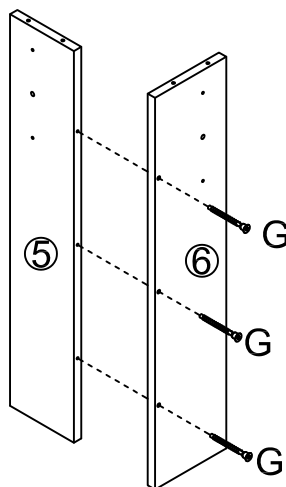

G  M5X50
3 PCS

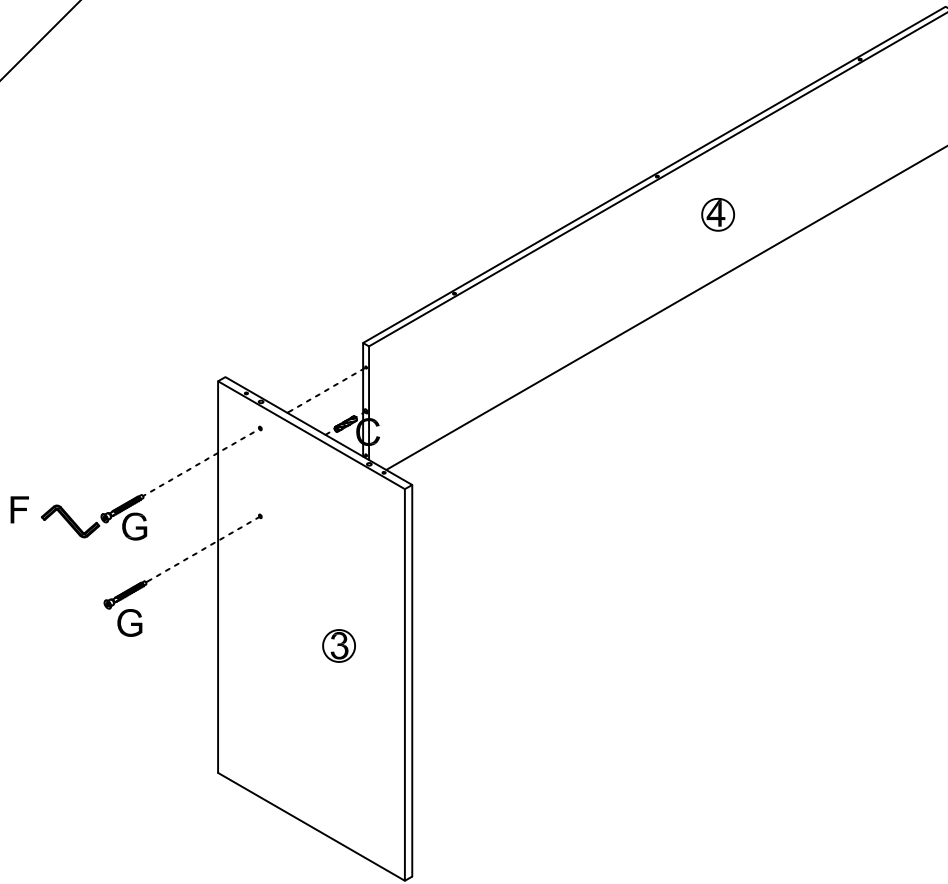

3



.Hardwares

| | | |
|---|---|----------------|
| G |  | M5X50 2 PCS |
| C |  | M6X30 1 PC |
| F |  | 1 PC |

4

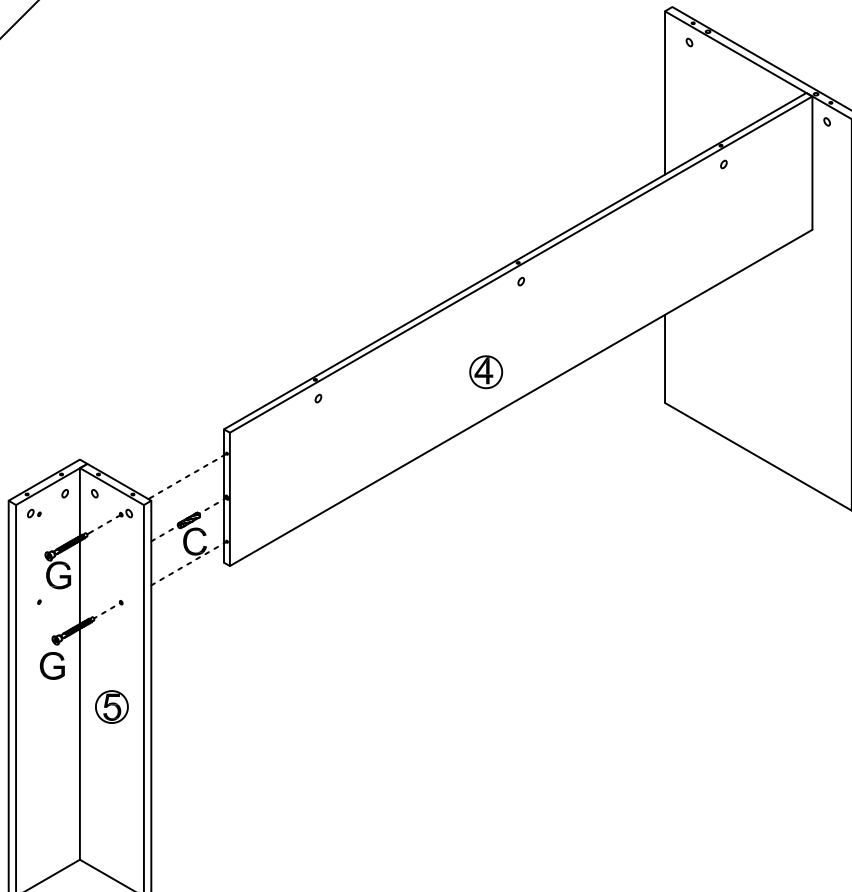

.Hardwares

| | | |
|---|---|----------------|
| G |  | M5X50 2 PCS |
| C |  | M6X30 1 PC |

5

.Hardwares

G  M5X50
4 PCS

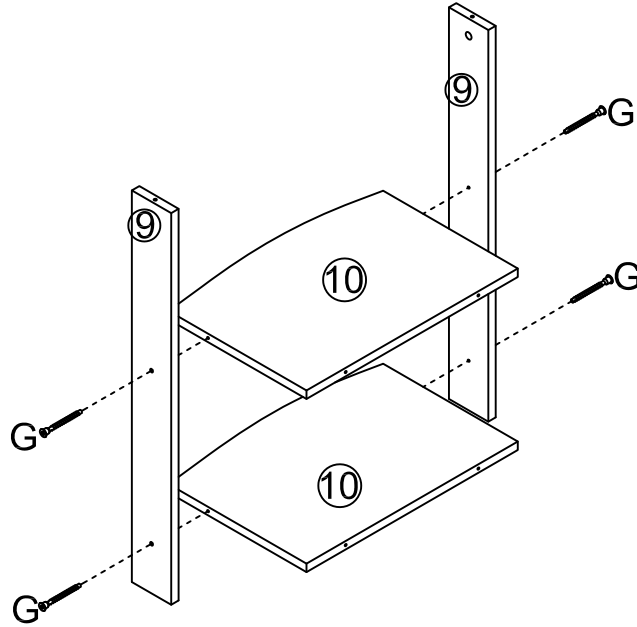

6

.Hardwares

G  M5X50
4 PCS

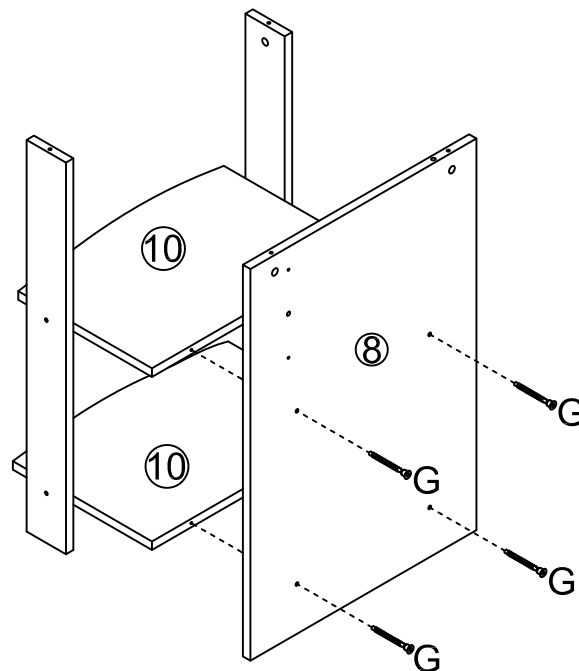

7

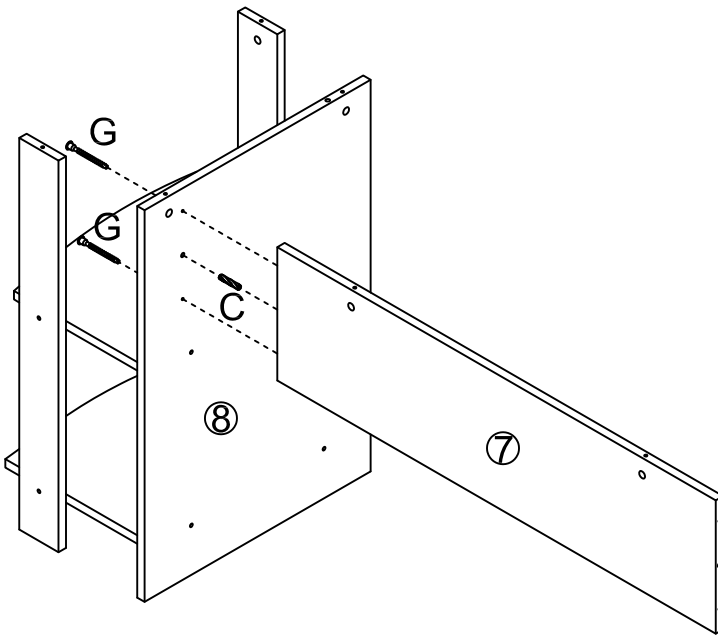

.Hardwares

G  M5X50
2 PCS

C  M6X30
1 PC

8

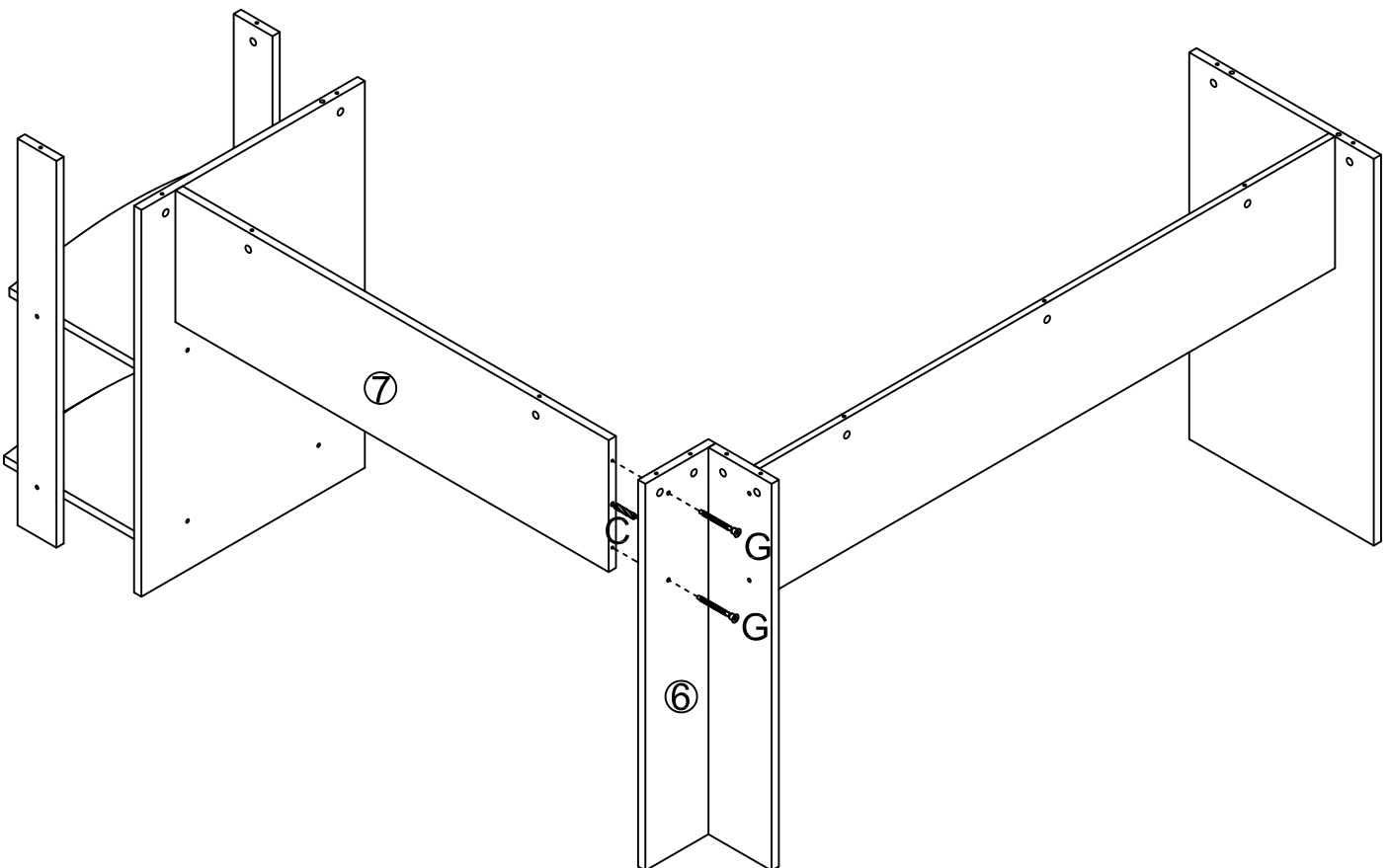



.Hardwares

G  M5X50
2 PCS

C  M6X30
1 PC

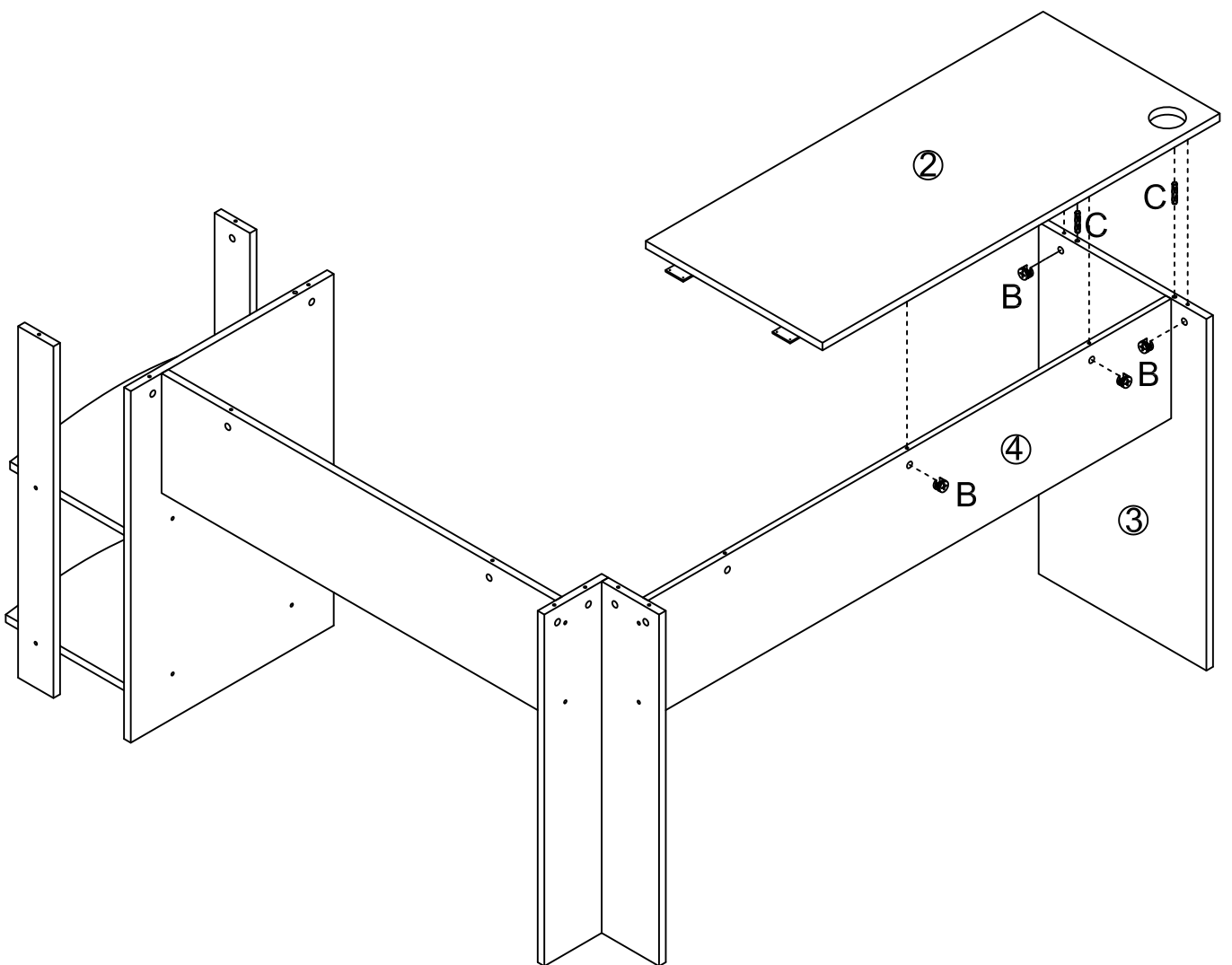

9

| .Hardwares | |
|------------|--|
| B |  4 PCS |
| C |  M6X30 2 PCS |



10

.Hardwares

| | | |
|---|---|----------------|
| B |  | 11 PCS |
| C |  | M6X30 2 PCS |
| D |  | M4X14 4 PCS |

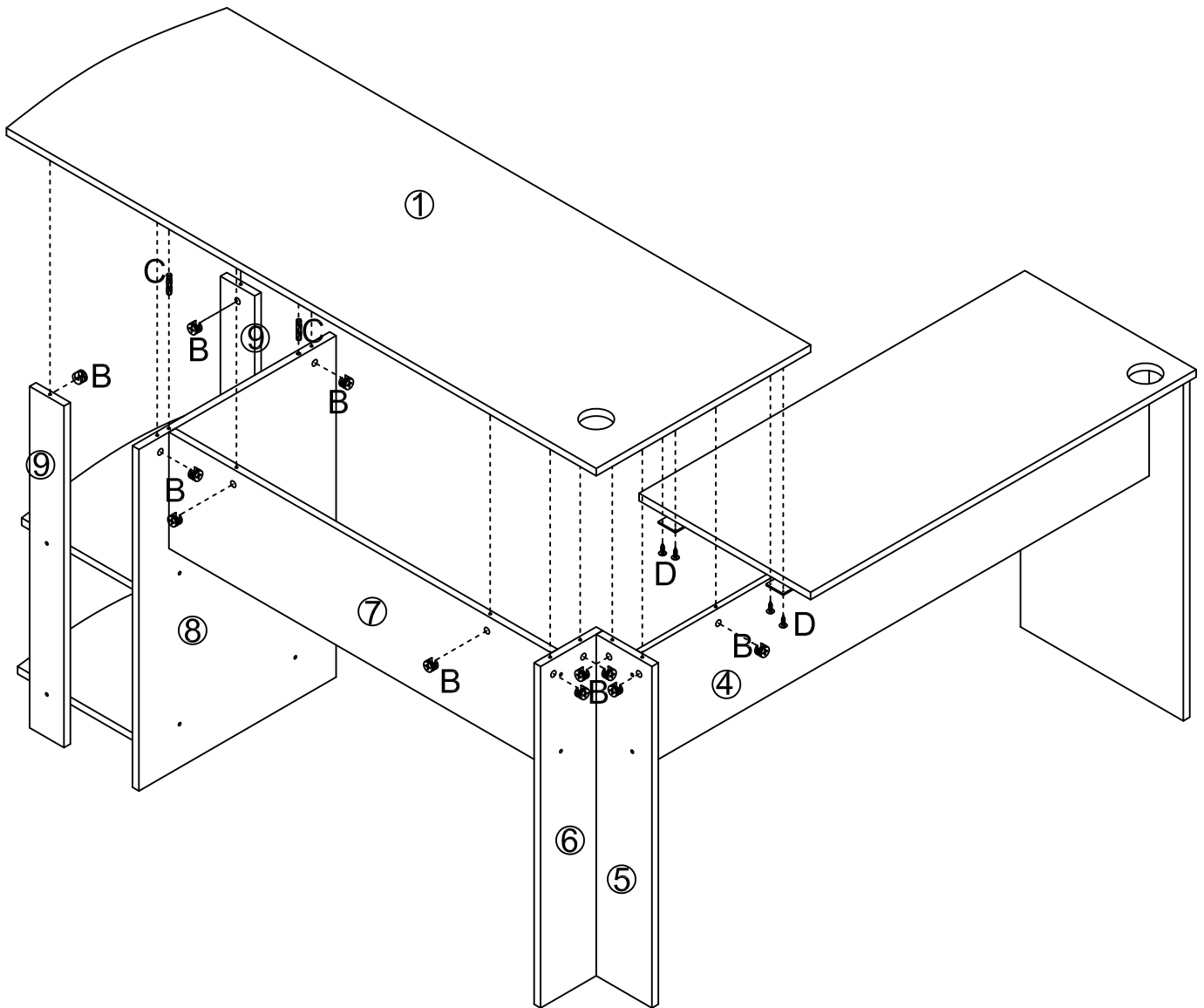

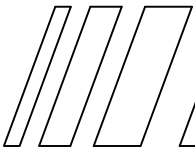

11

.Hardwares

H



2 PCS

