

# A 66( 0 % < , 1 6758&7,2 1

- **Twin/XL**( ZB01/02 ) .....

[CLICK HERE](#)

Size: 75"L×39"W/ 80"L×39"W

- **Full/Queen**( ZB03/04 ) .....

[CLICK HERE](#)

Size: 75"L×54"W/80"L×60 :

- **King /CK**( ZB05/06 ) .....

[CLICK HERE](#)

Size: 80"L×70"W/ 72"L×84"W

- 



# A 66( 0 % < ,16758&7,21

S /• Wt /El dt /E y>

N } š : T Z]• ]v•šOE š}v u vμ o %d • š} dÁ]v v dÁ]v y>•]ì X

D K EKd Z dhZE /Z d>zJ

I ( vÇ%OE OEu ]••]vP}OE u P UÁ Á]oPo oÇ•Z]%OE%o u vš  
(OE }( Z OE X

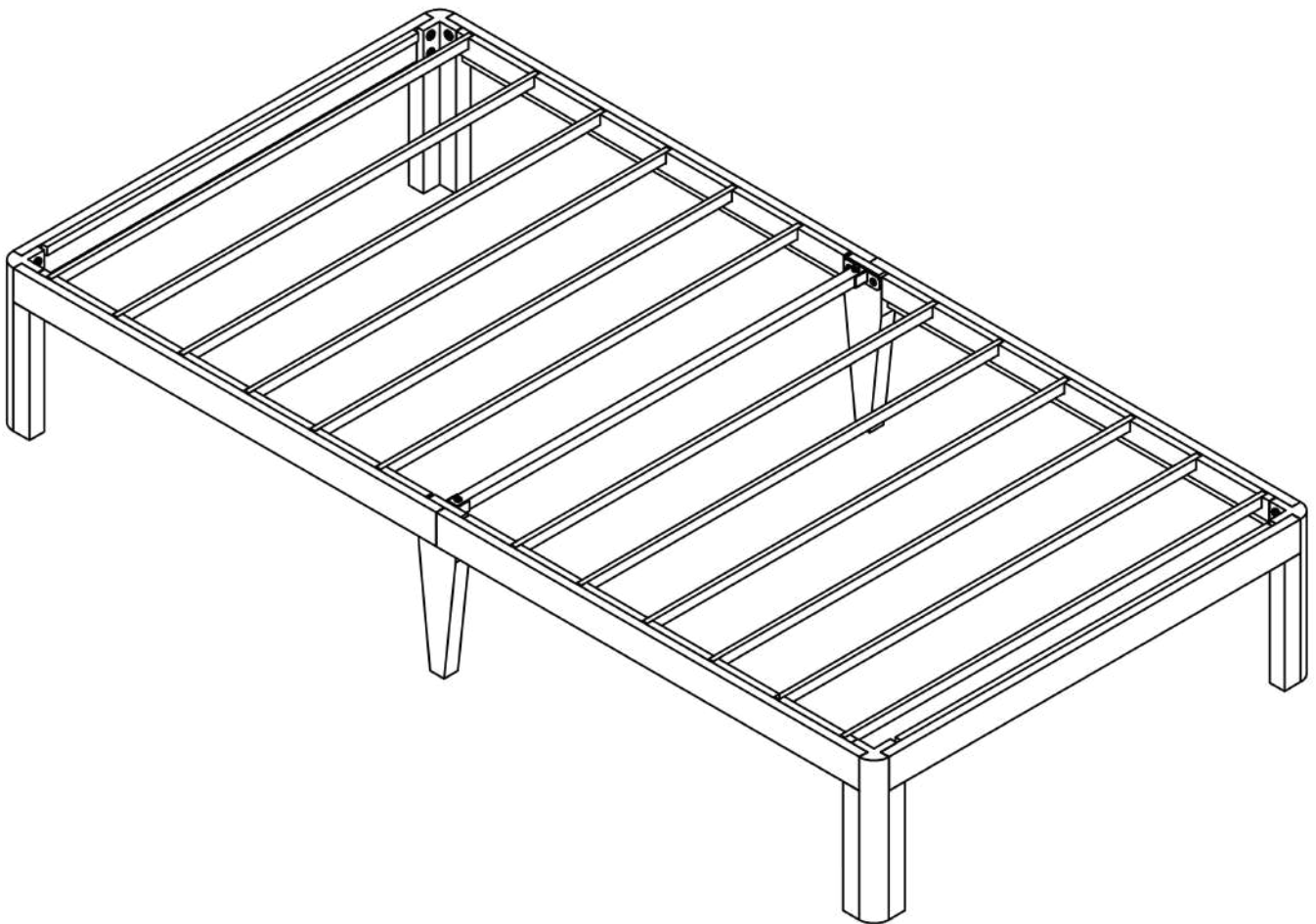

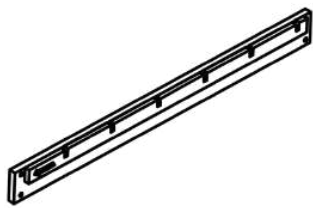

① Left Side Rail  
2PCS

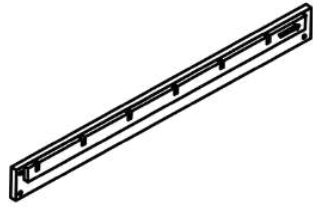

② Right Side Rail  
2PCS



③ Middle Support Leg  
2PCS



④ Corner Leg  
4PCS

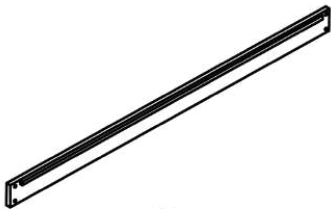

⑤ Side Bracket  
2PCS



⑧ Center Support Bar  
1PC

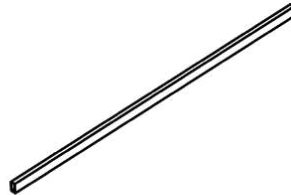

⑩ Slat  
12PCS



⑪ Side Rail Connector  
2PCS

### Hardware Kit



A×26PCS  
M8\*26mm



E×20PCS



# Parts



This page lists all the items included in this package. Please identify the hardware and individual components before beginning assembly.

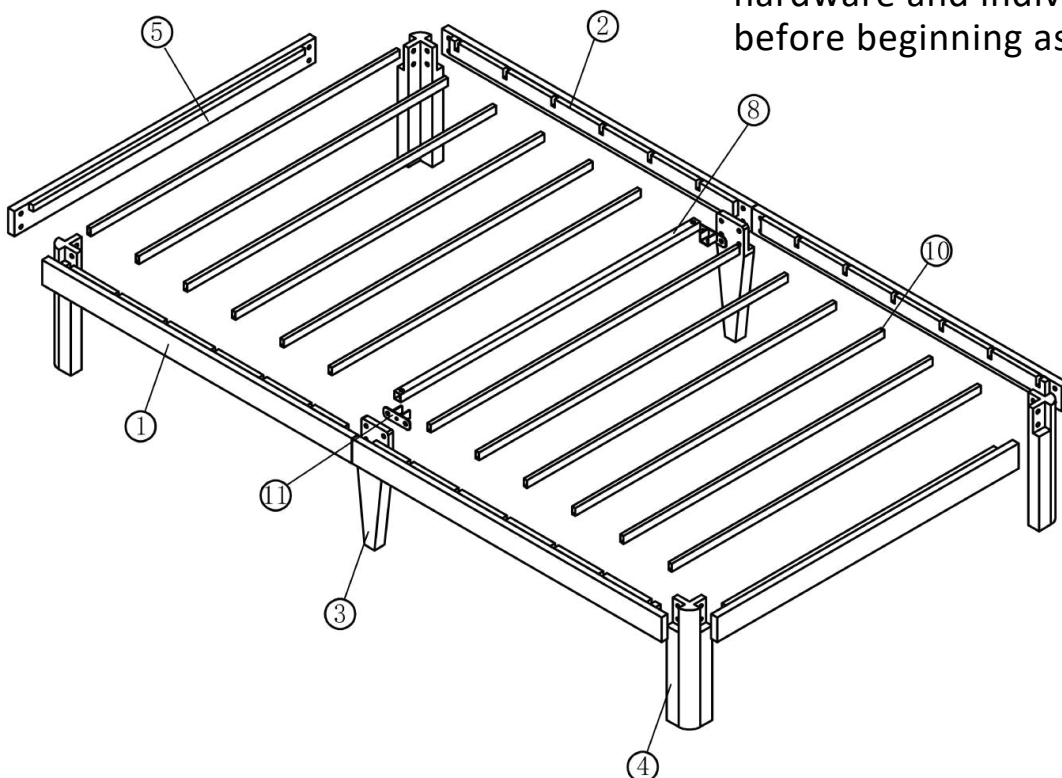

# Step 1

## Assembly of Side Rails

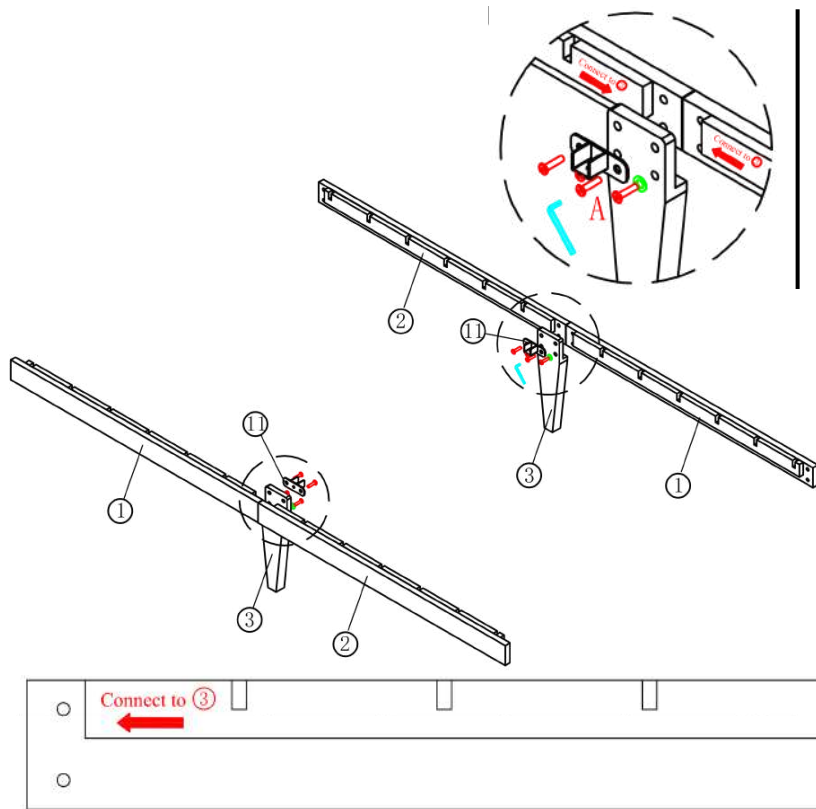

- Follow the sign to connect the left rail ① , right rail ② and middle support leg ③ by using side rail connectors ⑪ , bolts(A) and gasket (E). The gasket should be installed to the bottom holes.



A×8PCS  
M8\*26mm



E×4PCS



**Note:** The hole spacing on both sides of the side rail is different. Please make sure to confirm the corresponding positions during installation.

# Step 2

## Mounting the Corner Leg

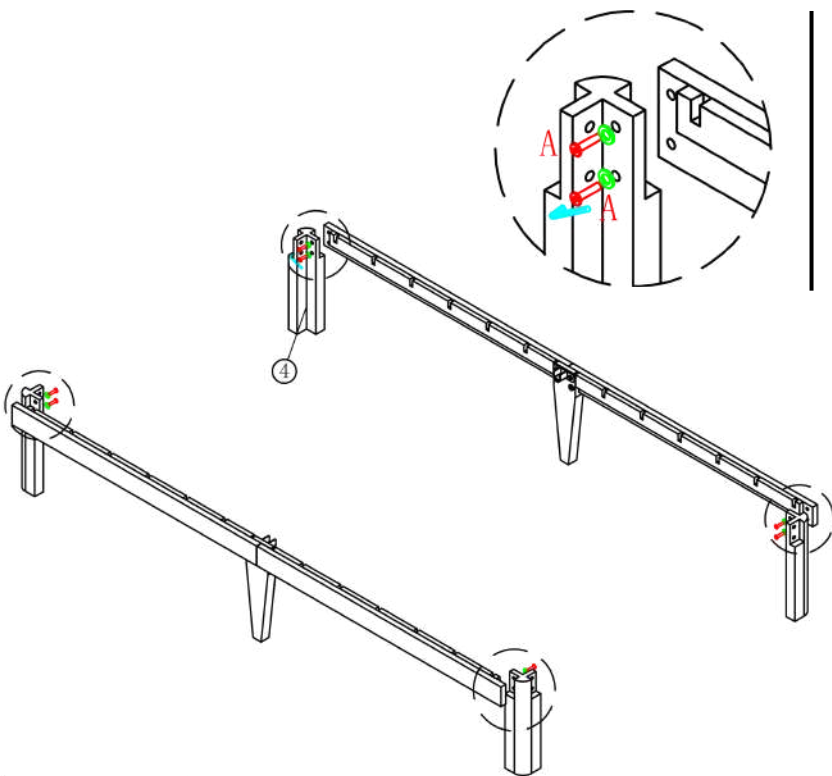

- Secure the corner legs and side rails with bolts(A) and gasket (E).
- Once all bolts are in place, use the provided Allen wrench to fully tighten each bolt.



A×8PCS  
M8\*26mm



E×8PCS



**Note:** The hole spacing on both sides of the side rail is different. Please make sure to confirm the corresponding positions during installation.

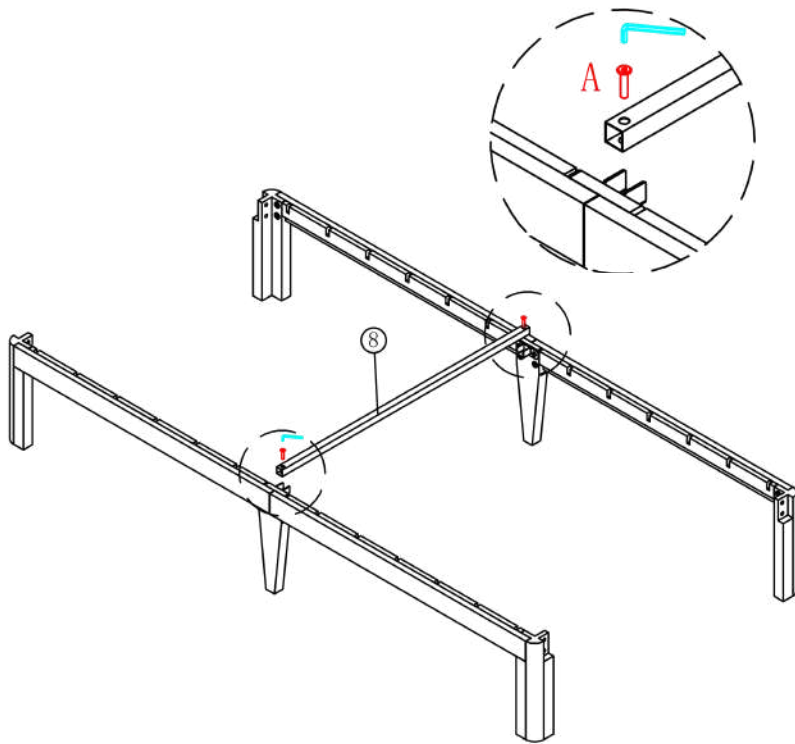

## Step 3

### Installing the Center Support Bar

- Secure all connections. Use bolt (A) to fasten the center support bar.



A×2PCS  
M8\*26mm



**Note:** Ensure all connections are properly aligned before final tightening. This step is crucial for the bed's stability.

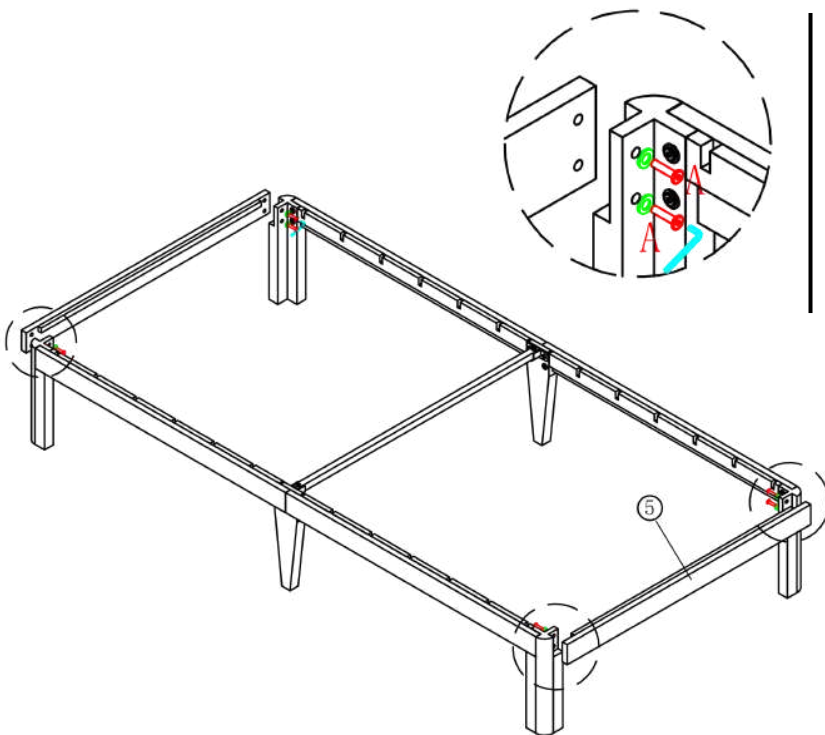

## Step 4

### Assembling the Bed Frame

- Secure the corner legs and side brackets with bolts(A) and gasket (E).
- Once all bolts are in place, use the provided Allen wrench to fully tighten each bolt.



A×8PCS  
M8\*26mm



E×8PCS



**Note:** Ensure all connections are properly aligned before final tightening. This step is crucial for the bed's stability

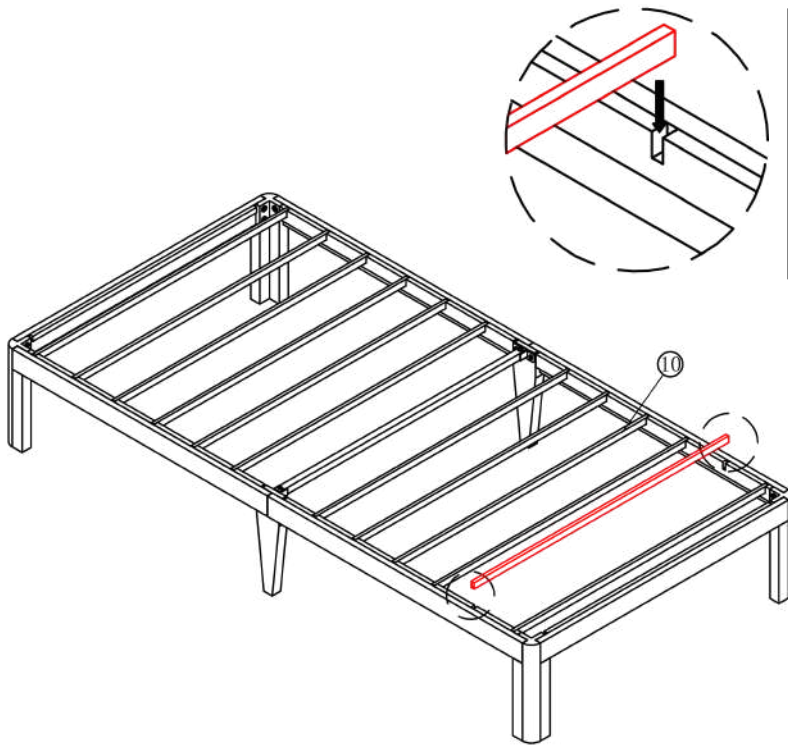

## Step 5

### Installing the Bed Slats

- Place all bed slats across the side rails as shown in the diagram. Each slat should be securely positioned in the designated slots.



**Note:** Before completing assembly, double-check that all screws and components are fully tightened.

# ASSEMBLY & INSTRUCTION

**SIZE: FULL/QUEEN**

Notice: This instruction manual applies to Full and Queen size.

**DO NOT RETURN DIRECTLY!**

If any parts are missing or damaged, we will gladly ship replacements free of charge.

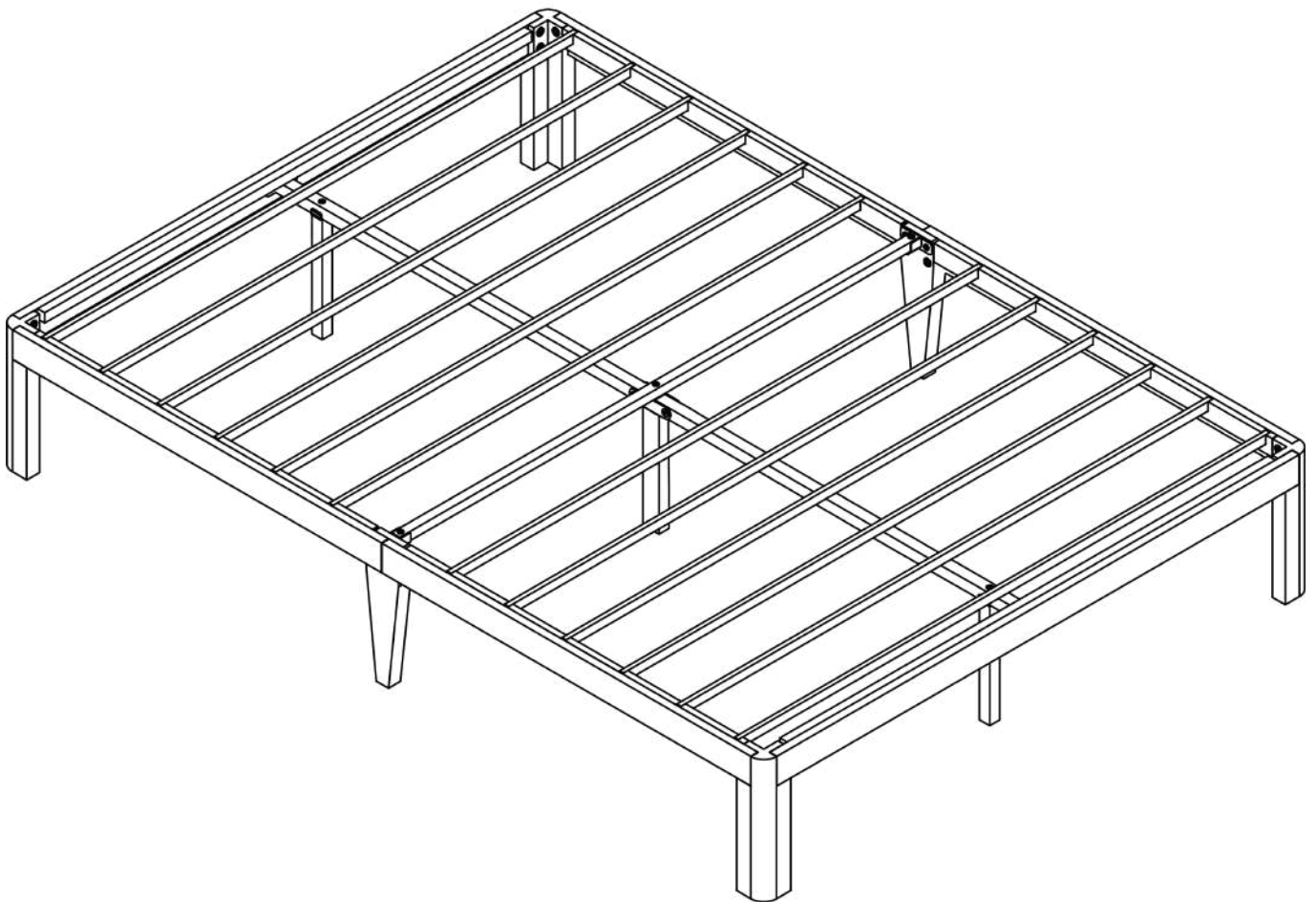

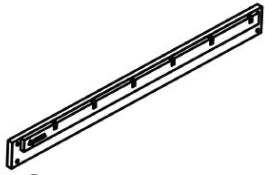

① Left Side Rail  
2PCS

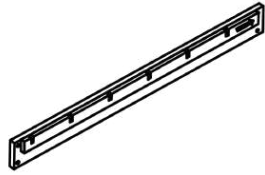

② Right Side Rail  
2PCS



③ Middle Support Leg  
2PCS



④ Corner Leg  
4PCS



⑤ Side Bracket  
2PCS

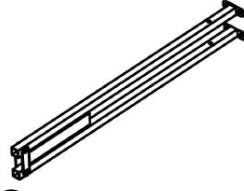

⑥ Center Support Rail  
1PC



⑦ Support Leg  
2PCS

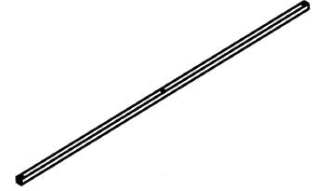

⑧ Center Support Bar  
1PC



⑩ Slat  
12PCS



⑪ Side Rail Connector  
2PCS

### Hardware Kit



A×26PCS  
M8\*26mm



B×4PCS  
M8\*14mm



C×2PCS  
M8\*33mm



D×1PCS  
M8\*53mm



E×20PCS



# Parts



This page lists all the items included in this package. Please identify the hardware and individual components before beginning assembly.

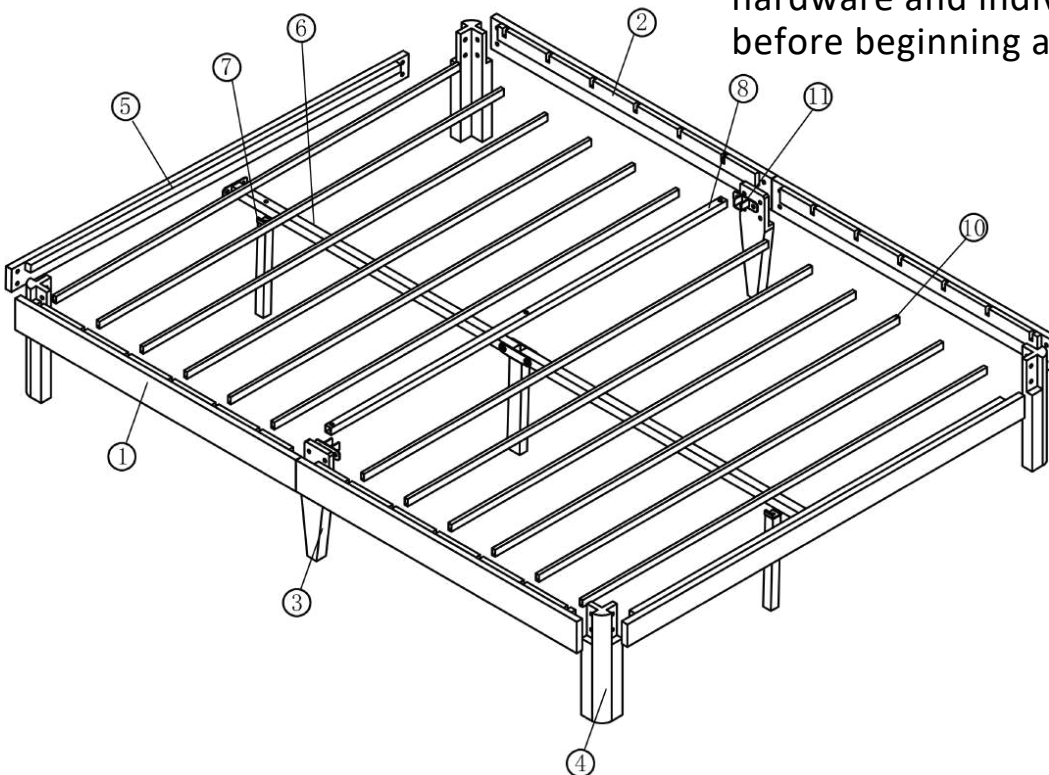

# Step 1

## Assembly of Side Rails

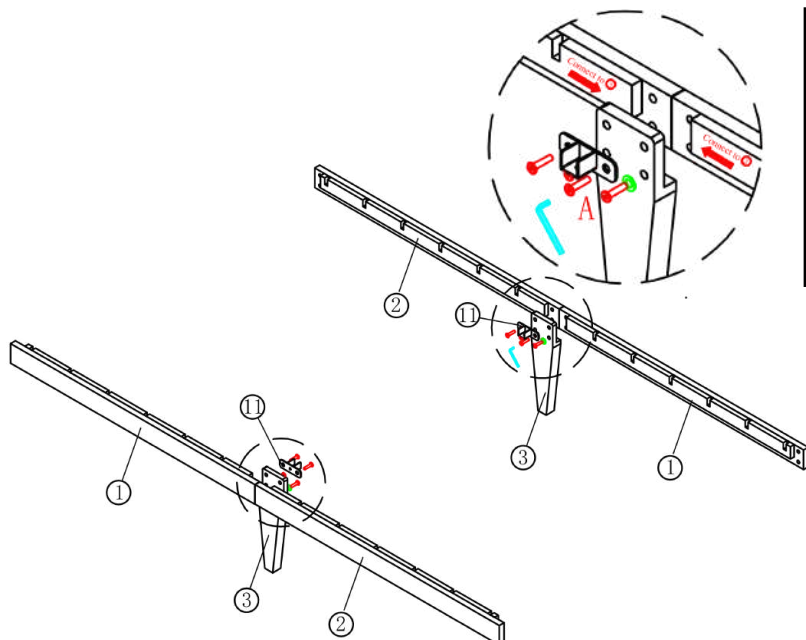

- Follow the sign to connect the left rail ①, right rail ② and middle support leg ③ by using side rail connectors ⑪, bolts(A) and gasket (E). The gasket should be installed to the bottom holes.

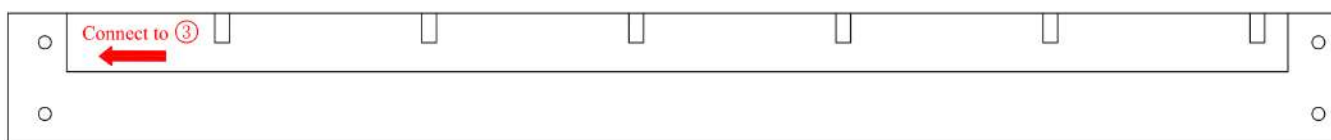

A×8PCS  
M8\*26mm



E×4PCS



**Note:** The hole spacing on both sides of the side rail is different. Please make sure to confirm the corresponding positions during installation.

# Step 2

## Mounting the Corner Leg

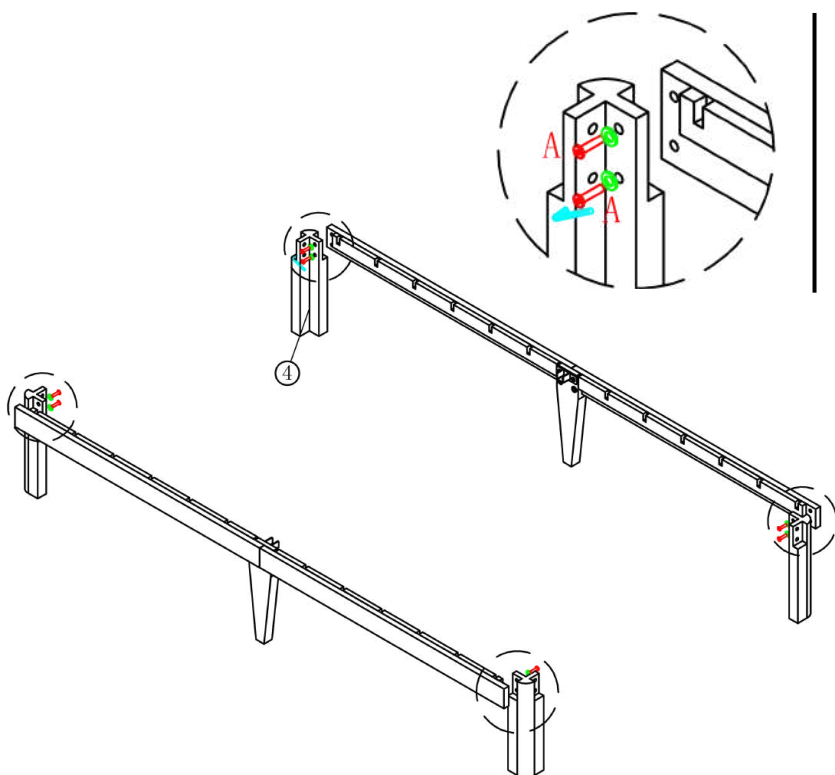

- Secure the corner legs and side rails with bolts (A) and gasket (E).
- Once all bolts are in place, use the provided Allen wrench to fully tighten each bolt.



A×8PCS  
M8\*26mm



E×8PCS



**Note:** The hole spacing on both sides of the side rail is different. Please make sure to confirm the corresponding positions during installation.

## Step 3

### Assembling the Bed Frame

- Secure the corner legs and side brackets with bolts (A) and gasket (E).
- Once all bolts are in place, use the provided Allen wrench to fully tighten each bolt

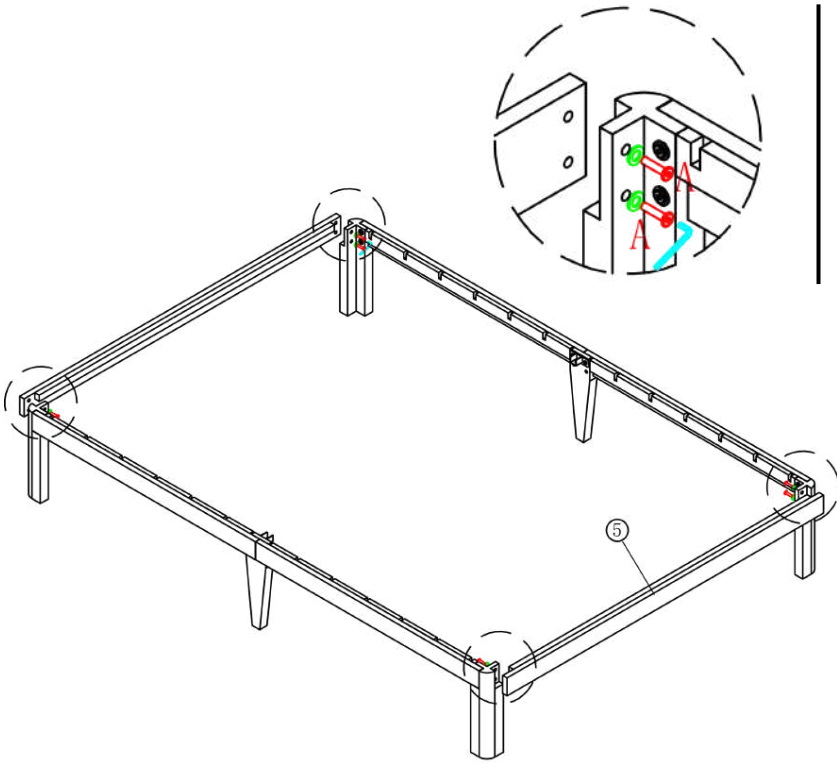

A×8PCS  
M8\*26mm



E×8PCS



**Note:** Ensure all connections are properly aligned before final tightening. This step is crucial for the bed's stability.

## Step 4

### Installing the Center Support Rail

- Attach the center support rail (6) to both ends of the bed frame using bolts (B).

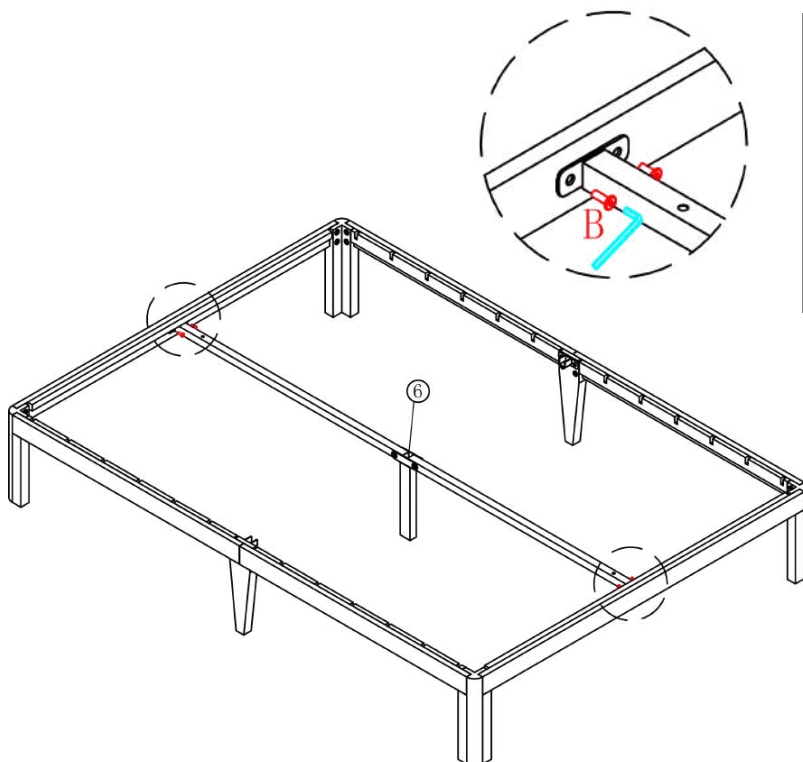

B×4PCS  
M8\*14mm



**Note:** Ensure all connections are properly aligned before final tightening. This step is crucial for the bed's stability

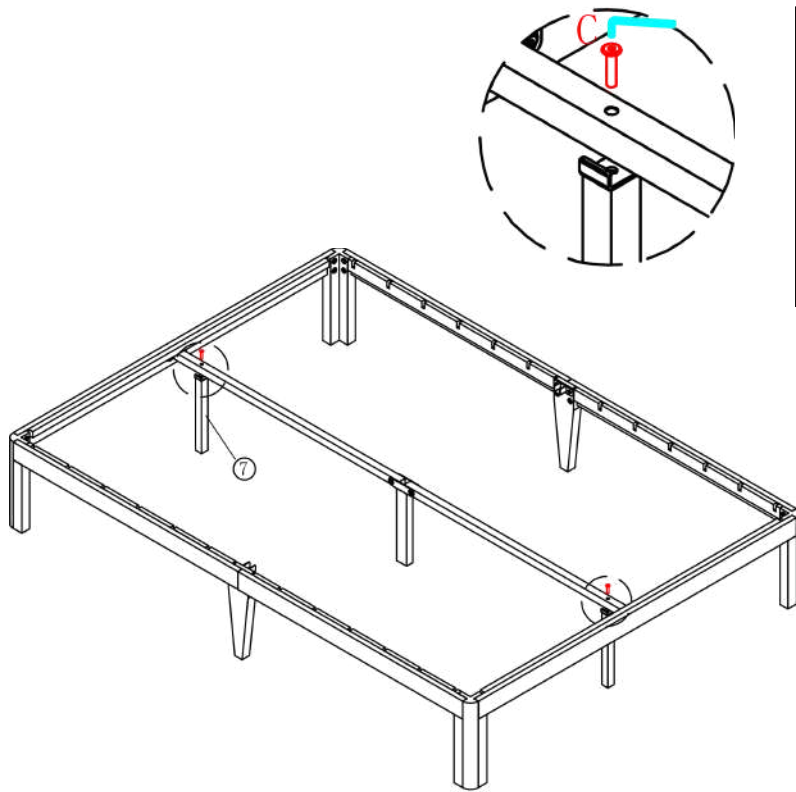

## Step 5

### Installing the Support Legs

- Attach the support legs ⑦ to the center support rail ⑥ using bolts (C)



**Note:** Ensure all connections are properly aligned before final tightening. This step is crucial for the bed's stability.

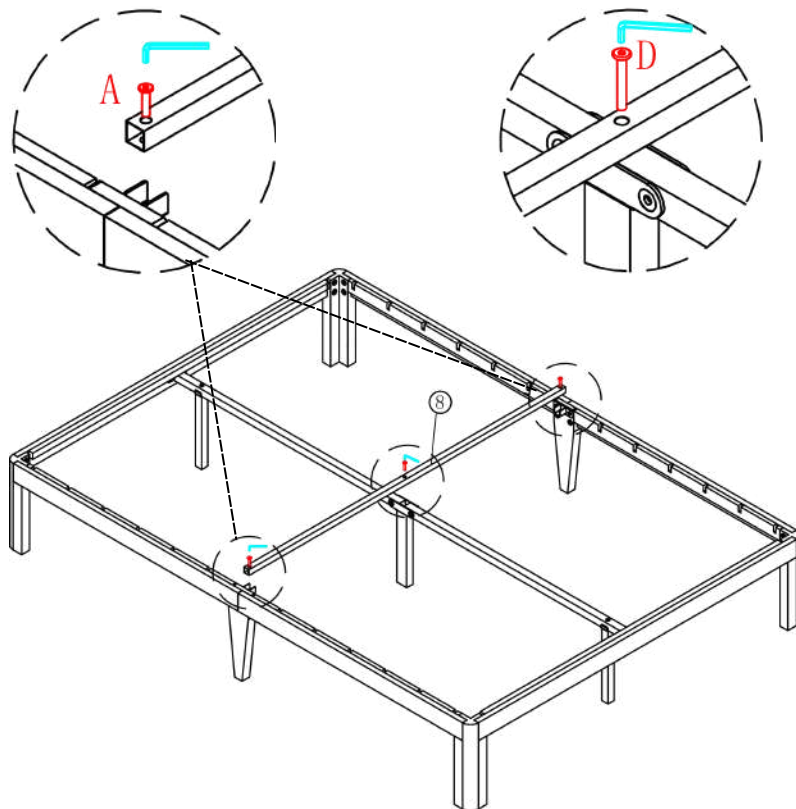

## Step 6

### Installing the Center Support Bar

- Attach this bar to the center pole using bolt (D).
- Secure all connections. Use bolt (A) to fasten the center support bar.

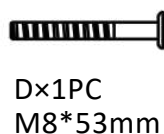
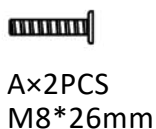

**Note:** Ensure all connections are properly aligned before final tightening. This step is crucial for the bed's stability.

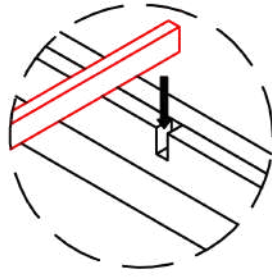

# Step 7

## Installing the Bed Slats

- Place all bed slats across the side rails as shown in the diagram. Each slat should be securely positioned in the designated slots.

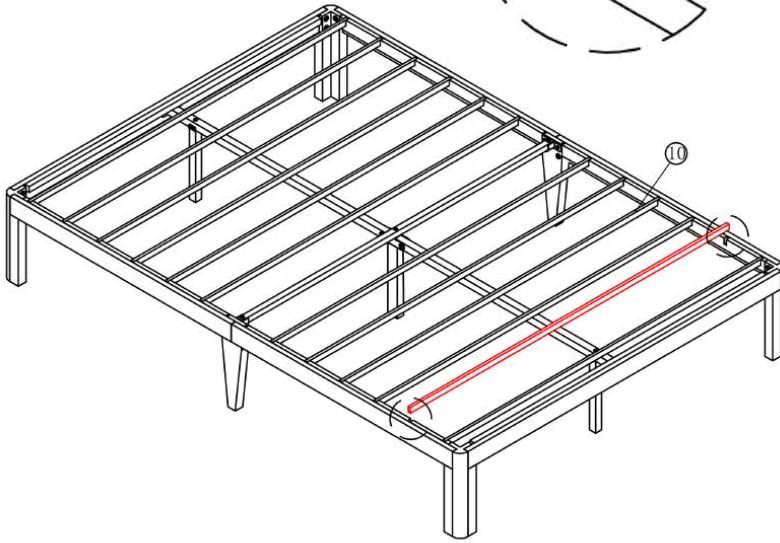

**Note:** Before completing assembly, double-check that all screws and components are fully tightened.

# ASSEMBLY & INSTRUCTION

## SIZE: KING/CALIFORNIA KING

Notice: This instruction manual applies to King and California King size.

## DO NOT RETURN DIRECTLY!

If any parts are missing or damaged, we will gladly ship replacements free of charge.

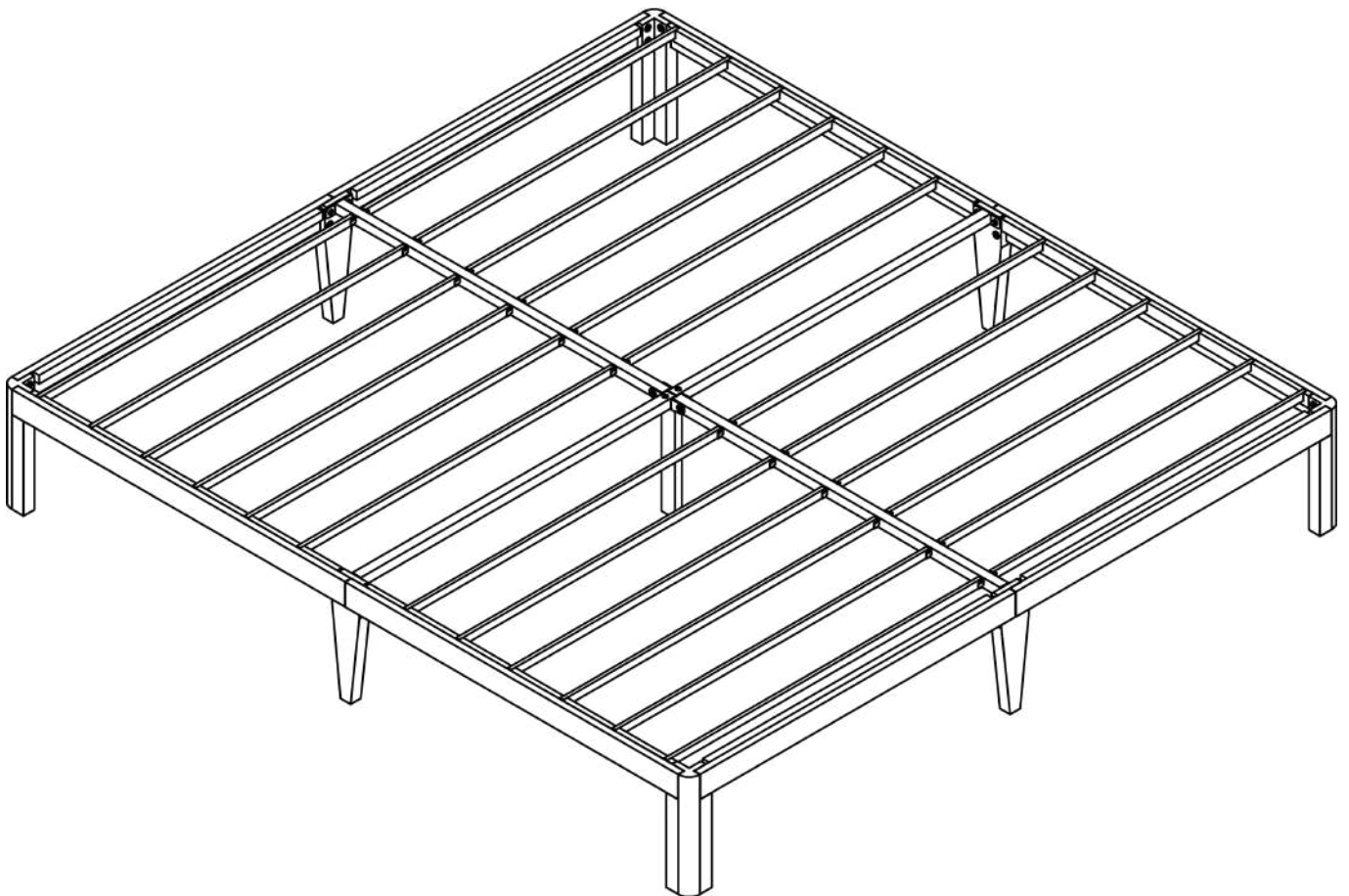

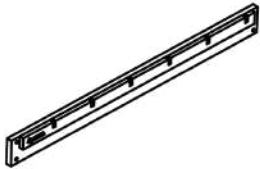

① Left Side Rail  
2PCS



② Right Side Rail  
2PCS



③ Middle Support Leg  
4PCS



④ Corner Leg  
4PCS



⑤ Left Side Bracket  
2PCS

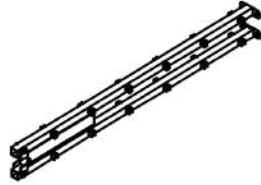

⑥ Center Support Rail  
1PC



⑦ Right Side Bracket  
2PCS

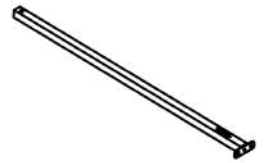

⑧ Center Support Bar  
2PCS



⑩ Slat  
24PCS

### Hardware Kit



A×32PCS  
M8\*26mm



C×2PCS  
M8\*33mm



E×24PCS



## Parts

This page lists all the items included in this package. Please identify the hardware and individual components before beginning assembly.

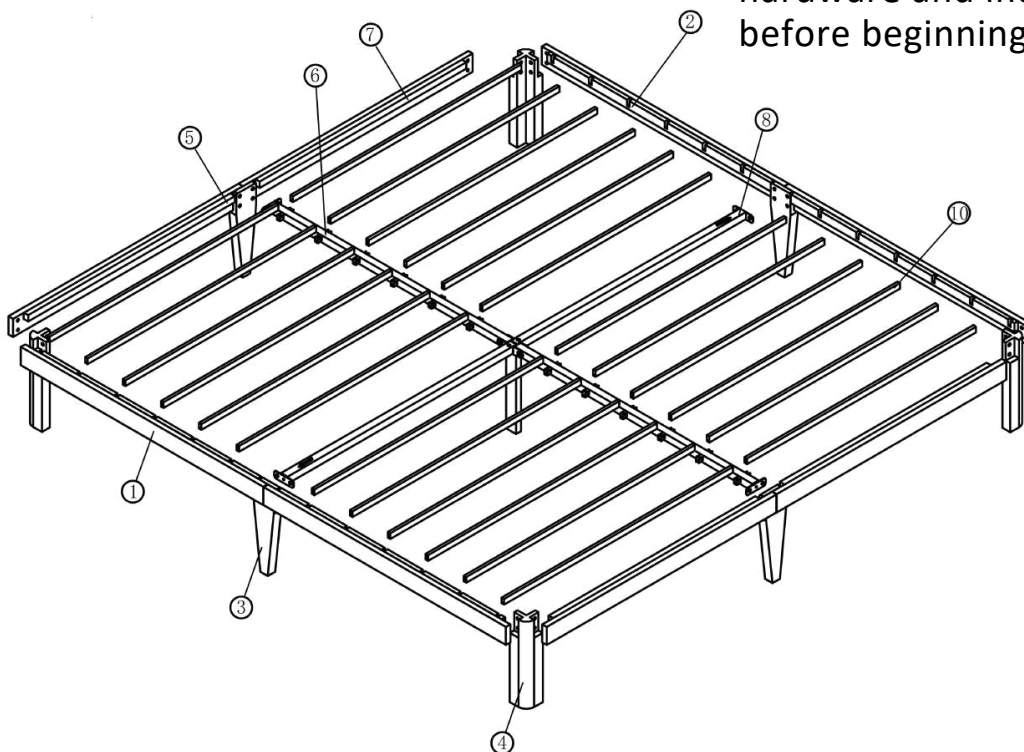

# Step 1

## Assembly of Side Rails

- Follow the sign to connect the left rail ①, right rail ② and middle support leg ③ by using bolts(A) and gasket (E). The bolts and gaskets should be installed to the bottom holes.

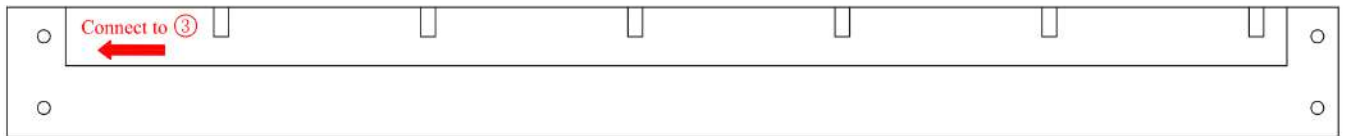
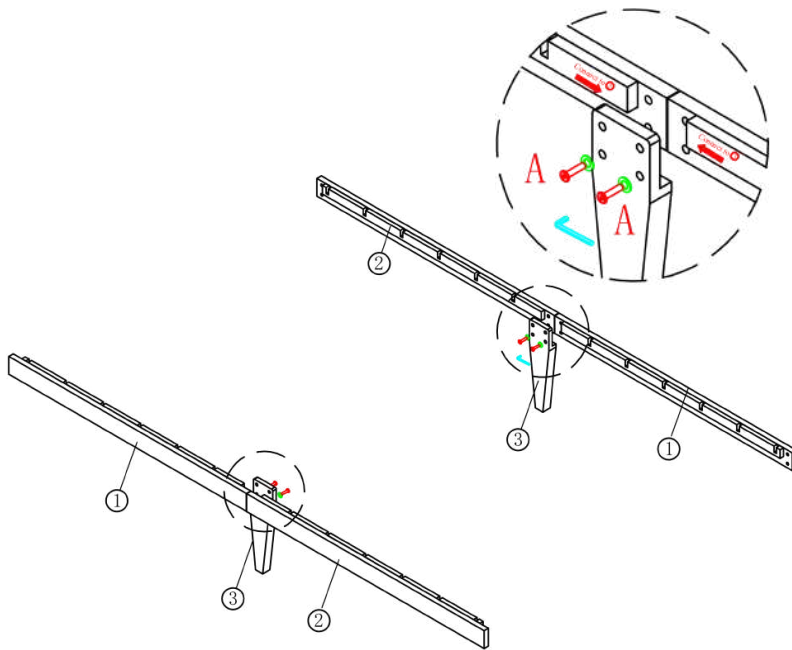

A×4PCS  
M8\*26mm



E×4PCS



**Note:** The hole spacing on both sides of the side rail is different. Please make sure to confirm the corresponding positions during installation.

# Step 2

## Mounting the Corner Leg

- Secure the corner legs and side rails with bolts(A) and gasket (E).
- Once all bolts are in place, use the provided Allen wrench to fully tighten each bolt.

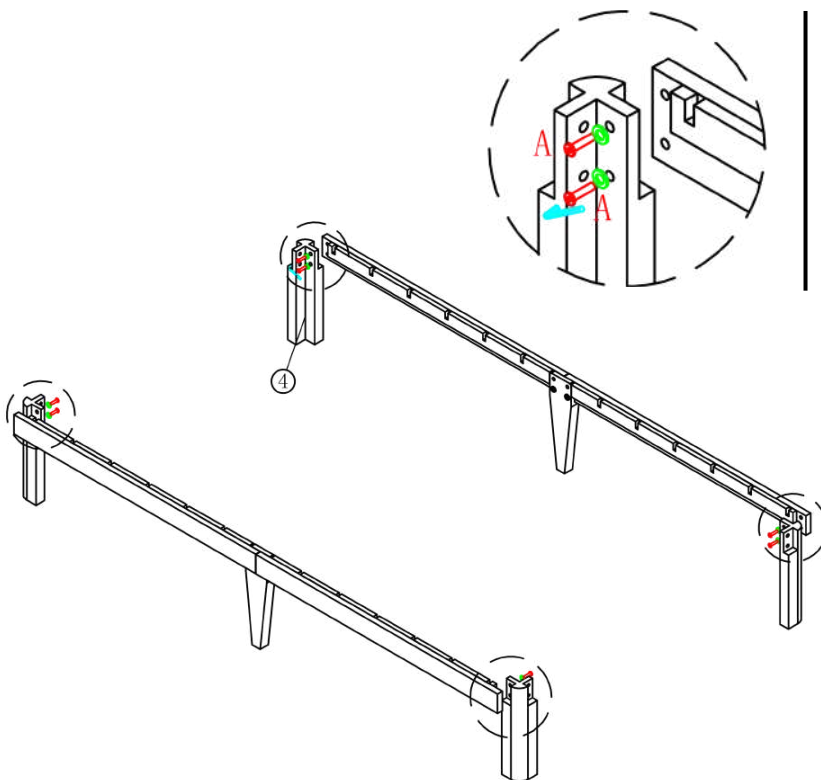

A×8PCS  
M8\*26mm



E×8PCS



**Note:** The hole spacing on both sides of the side rail is different. Please make sure to confirm the corresponding positions during installation.

## Step 3

### Assembly of Side Brackets

- Follow the sign to connect the left bracket (5), right bracket (7) and middle support leg (3) by using bolts (A) and gasket (E). The bolts and gaskets should be installed to the bottom holes.

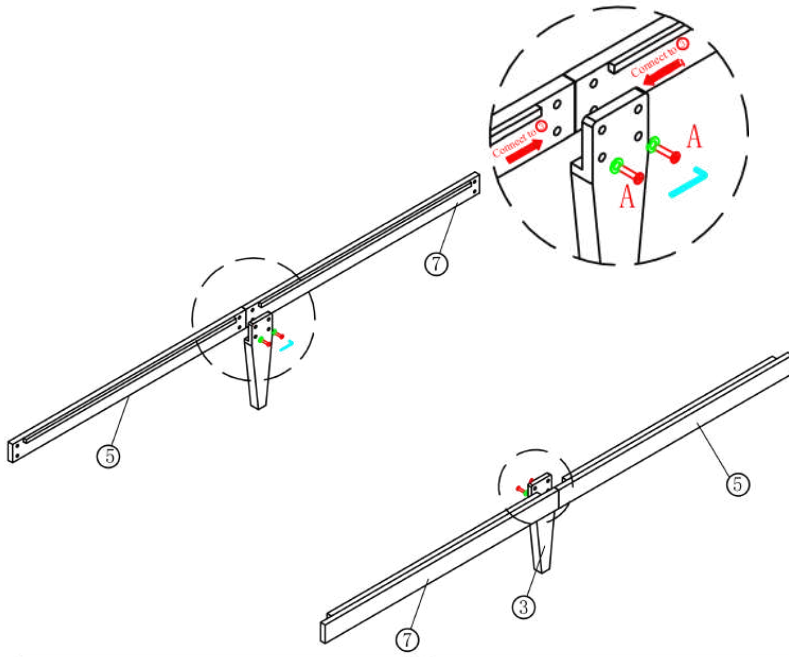

A×4PCS  
M8\*26mm



E×4PCS



**Note:** Ensure all connections are properly aligned before final tightening. This step is crucial for the bed's stability.

## Step 4

### Assembling the Bed Frame

- Secure the corner legs and side brackets with bolts(A) and gasket (E).
- Once all bolts are in place, use the provided Allen wrench to fully tighten each bolt.

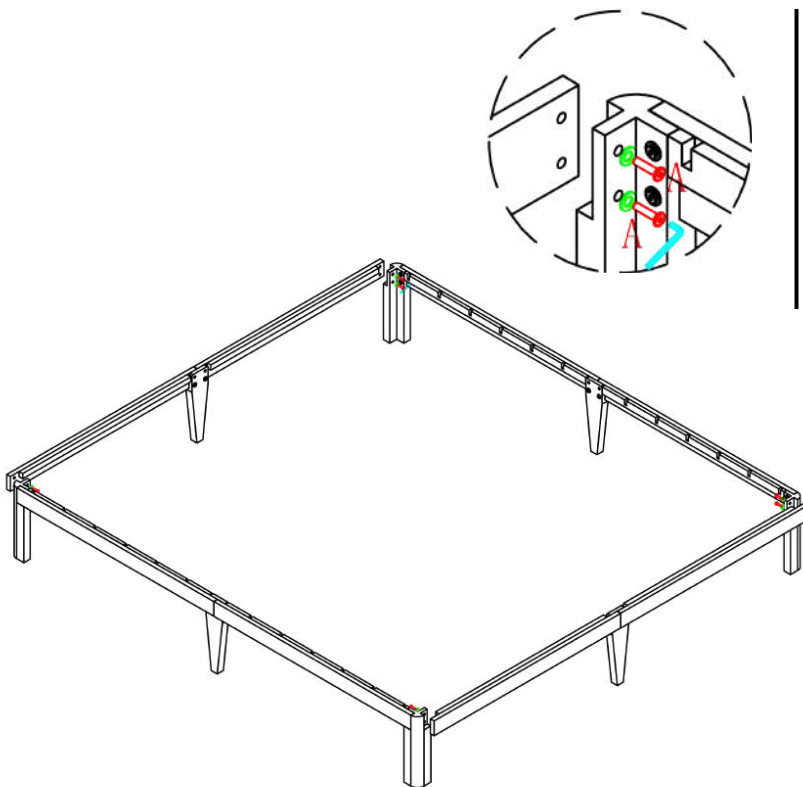

A×8PCS  
M8\*26mm



E×8PCS



**Note:** Ensure all connections are properly aligned before final tightening. This step is crucial for the bed's stability

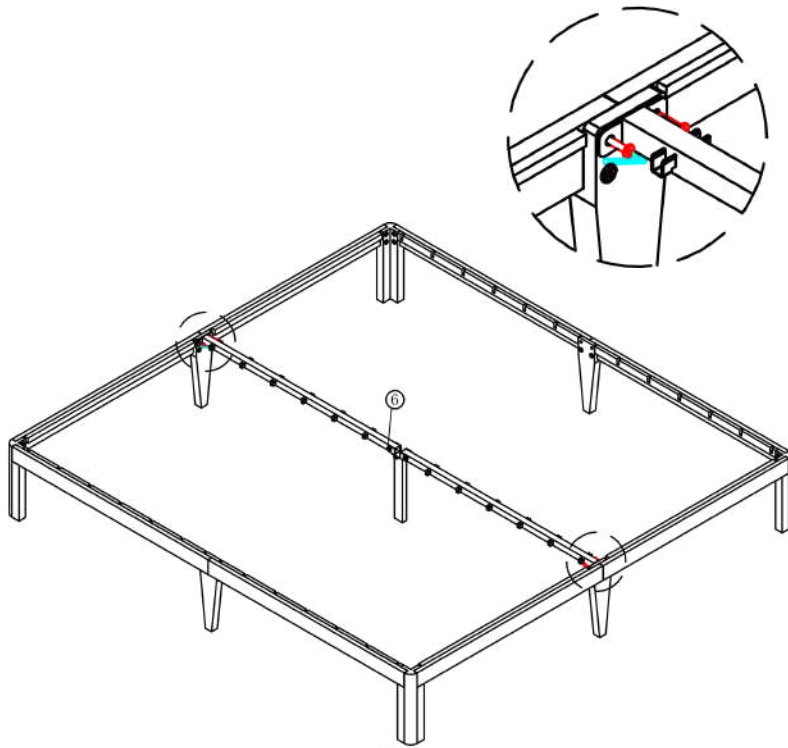

## Step 5

### Installing the Center Support Rail

- Attach the center support rail ⑥ to both ends of the bed frame using bolts (A).



A×4PCS  
M8\*26mm



**Note:** Ensure all connections are properly aligned before final tightening. This step is crucial for the bed's stability.

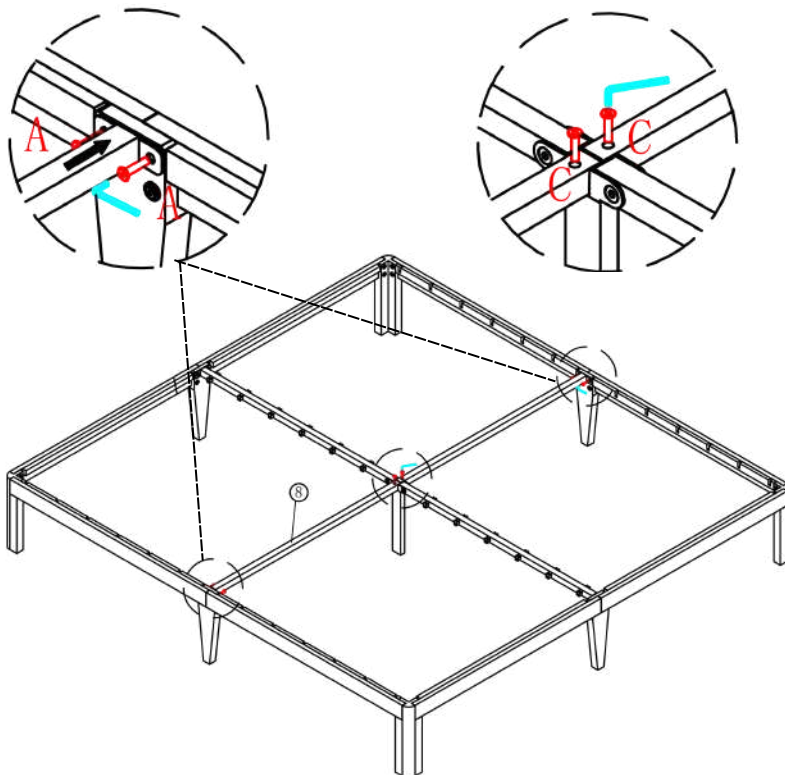

## Step 6

### Installing the Center Support Bar

- Make the sign face up and attach this bar to the center pole using bolt (C).
- Secure all connections. Use bolt (A) to fasten the center support bar.



A×4PCS  
M8\*26mm



C×2PCS  
M8\*33mm



**Note:** Ensure all connections are properly aligned before final tightening. This step is crucial for the bed's stability.

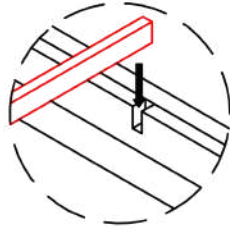

# Step 7

## Installing the Bed Slats

- Place all bed slats across the side rails as shown in the diagram. Each slat should be securely positioned in the designated slots.

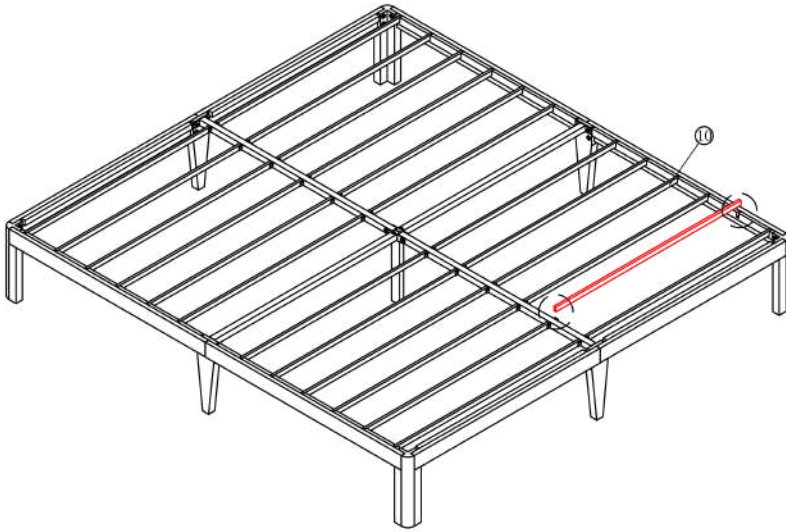

**Note:** Before completing assembly, double-check that all screws and components are fully tightened.