

⚠ WARNING



Children have died from furniture tipover. To reduce the risk of furniture tipover:

- ALWAYS install tipover restraint provided.
- NEVER put a TV on this product.
- NEVER allow children to stand, climb or hang on drawers, doors, or shelves.
- NEVER open more than one drawer at a time.
- Place heaviest items in the lowest drawers.
- Do not defeat or remove the drawer interlock system.

This is a permanent label.

Do not remove!

⚠ ATTENTION



Des enfants sont morts du basculement des meubles. Pour réduire le risque de basculement des meubles:

- TOUJOURS installer la retenue de basculement fournie.
- NE JAMAIS mettre de téléviseur sur ce produit.
- NE JAMAIS permettre aux enfants de se tenir debout, de grimper ou de s'accrocher à des tiroirs, des portes ou des étagères.
- N'ouvrez JAMAIS plus d'un tiroir à la fois.
- Placez les objets les plus lourds dans les tiroirs les plus bas.
- Ne désactivez pas et ne retirez pas le système de verrouillage du tiroir.

Ceci est une étiquette permanente.

Ne pas enlever!

⚠ WARNUNG









Kinder sind an einem Möbelkipp gestorben. So verringern Sie das Risiko eines Umkippen von Möbeln:

- Installieren Sie IMMER die mitgelieferte Kipprückhaltevorrichtung.
- Stellen Sie NIEMALS einen Fernseher an dieses Produkt.
- Lassen Sie Kinder NIEMALS an Schubladen, Türen oder Regalen stehen klettern oder hängen.
- Öffnen Sie NIEMALS mehr als eine Schublade gleichzeitig.
- Legen Sie schwerste Gegenstände in die untersten Schubladen.
- Besiegen oder entfernen Sie das Schubladenverriegelungssystem nicht.





Dies ist ein dauerhaftes Etikett.

Nicht entfernen!

Hardware

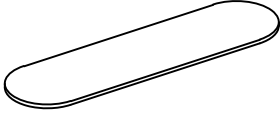
A	B	C	D	E	F
M6 x 30mm Bolt  4 pcs + 1 pc	M6 x 12mm Bolt  22 pcs + 1 pc	Foot Pad  6 pcs	Allen Key  1 pc	Anti-tipping Hardware  2 pcs	Anti-tipping Hardware  2 pcs

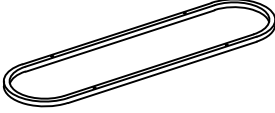
Parts

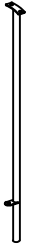
1	2	3	4	5
Table Top  1 pc	Shelf Panel  1 pc	Table Top Frame  1 pc	Table Leg  4 pcs	Table Leg  2 pcs

Overview

To give you an overview of all parts, the picture is to help you put the various parts into perspective. Please read through the instructions below to familiarise yourself with the parts and steps before assembly. This may require 2 people to assemble.

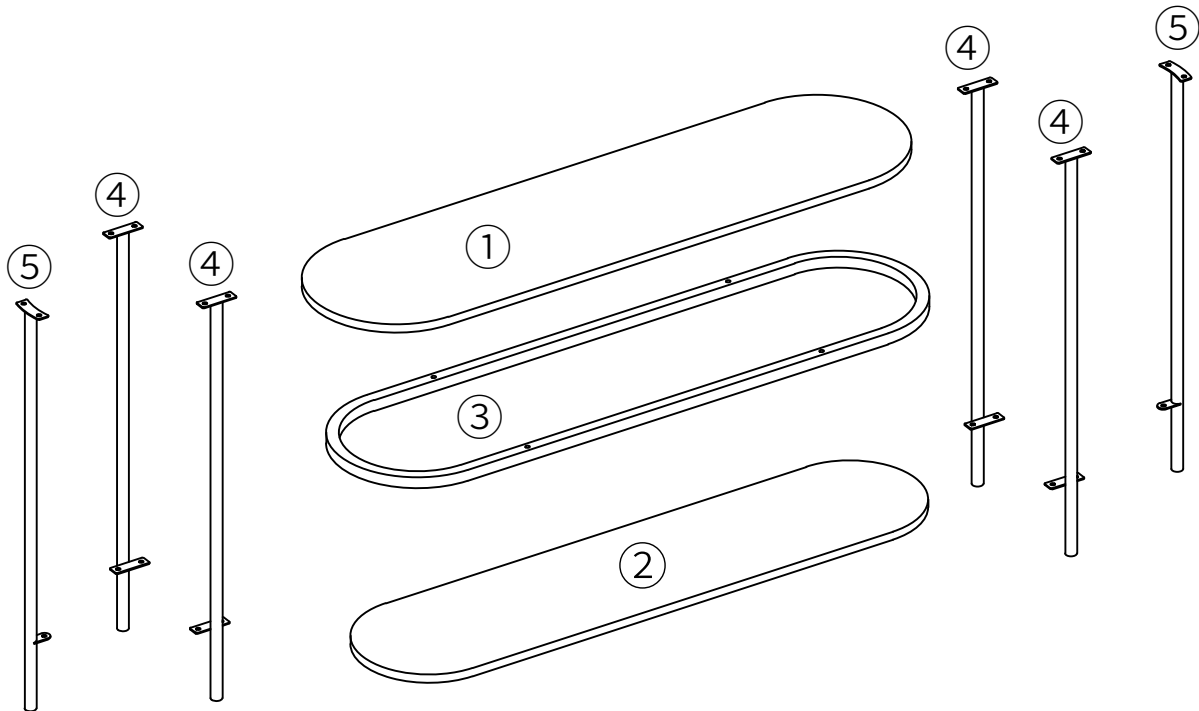

1

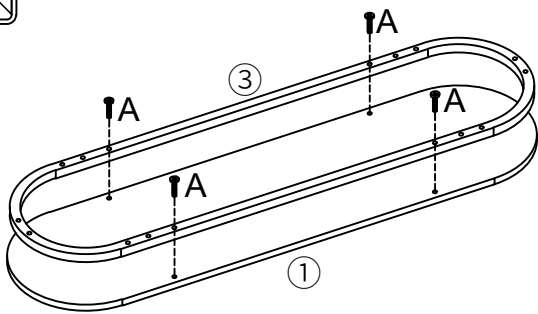
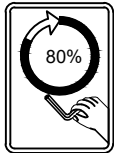

Assemble Table Top Frame to Table Top using Bolt A.

2

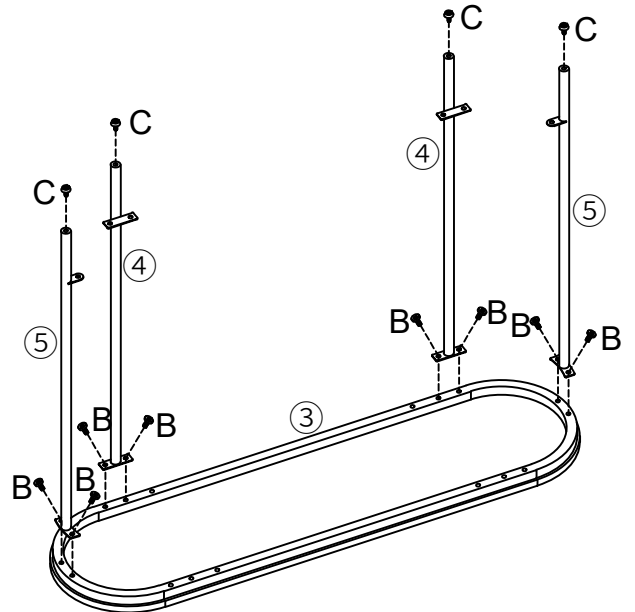

1. Assemble Table Legs (4 & 5) to Table Top Frame using Bolt B.
2. Attach Foot Pad C to Table Legs.

3

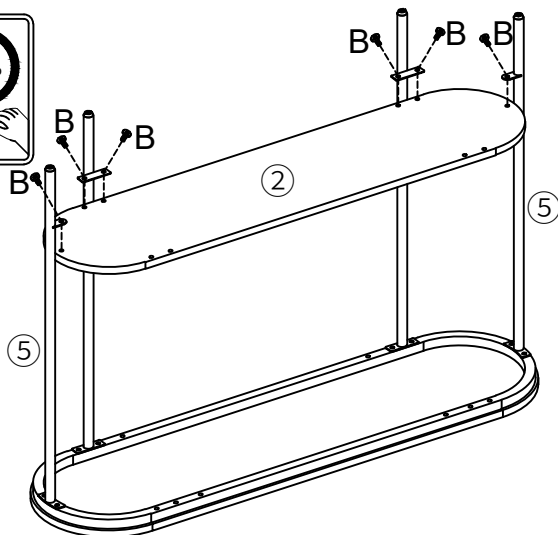
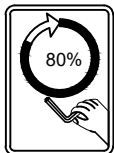

Assemble Shelf Panel (2) to Table Legs using Bolt B

4

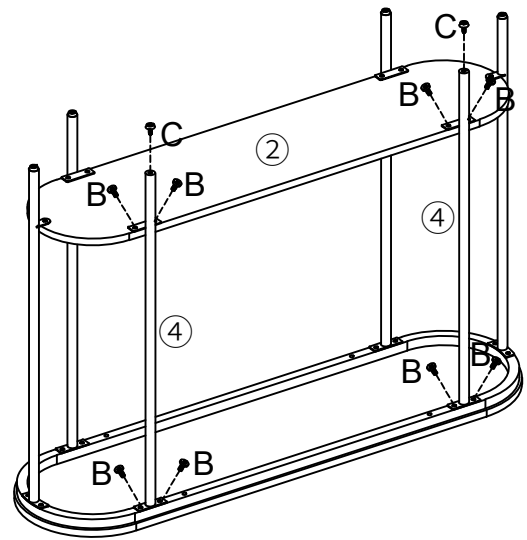
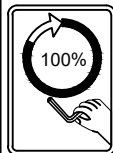

1. Assemble the rest Table Legs (4) to Table Top Frame (3) and Shelf Panel (2) using Bolt B.
2. Attach Foot Pad C to the 2 Table Legs.

5

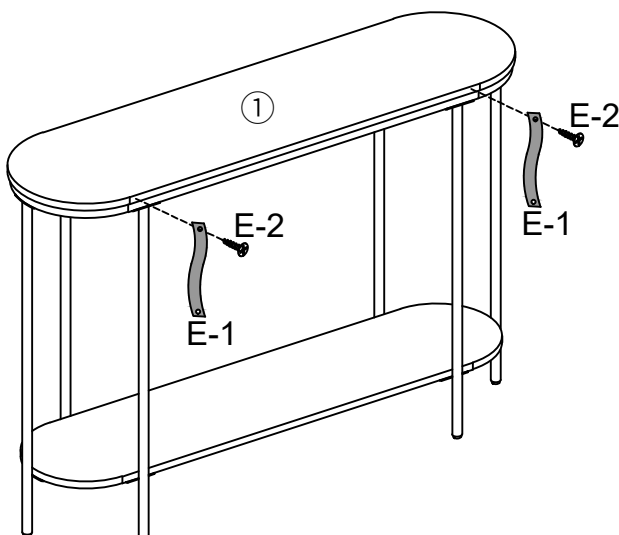

Assemble Anti-tipping Hardware E to Table Top (1) .

6

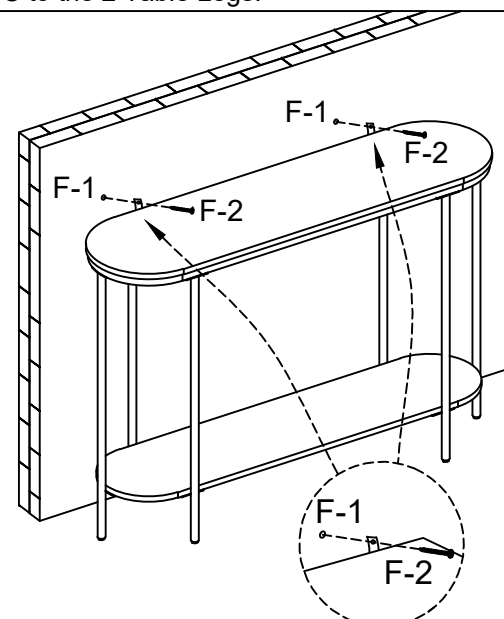
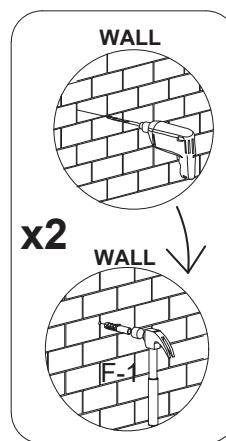

1. Drill 2 holes on the wall, and hammer Anti-tipping Hardware F-1 into the holes.
2. Secure the Ties E-1 to F-1 using Screws F-2.